

ZGD

Z-Series™ ROOFTOP UNITS

Standard Efficiency | Eco-Last™ Coil | **R-454B** | 60Hz

COMMERCIAL

PRODUCT SPECIFICATIONS (EHB)



3 to 6 Tons

Net Cooling Capacity – 35,000 to 67,000 Btuh

Gas Input Heat Capacity – 65,000 to 150,000 Btuh

Z-SERIES™

DESIGNED TO FIT. FAST.



ASHRAE
Standard
90.1

MODEL NUMBER IDENTIFICATION

Z G D 060 S 5 B H 1 Y

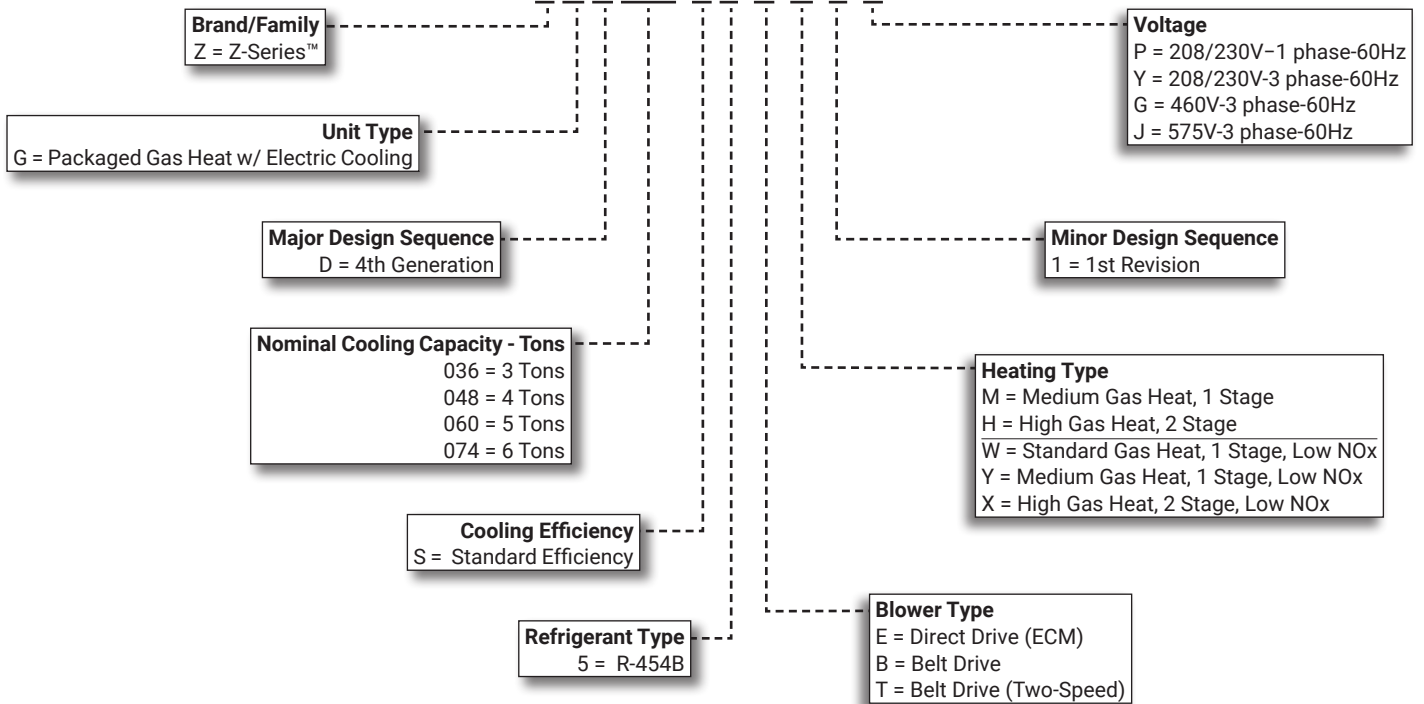

FEATURE HIGHLIGHTS

Z-Series™ rooftop units from Allied Commercial are the new standard for cost efficient reliable, efficient rooftop units built for long-lasting performance that can significantly improve indoor environments.

1. Heat Exchanger
2. Scroll Compressor
3. Eco-Last™ Coil System
4. Outdoor Coil Fan Motor
5. Heavy Gauge Steel Cabinet
6. Supply Air Blower

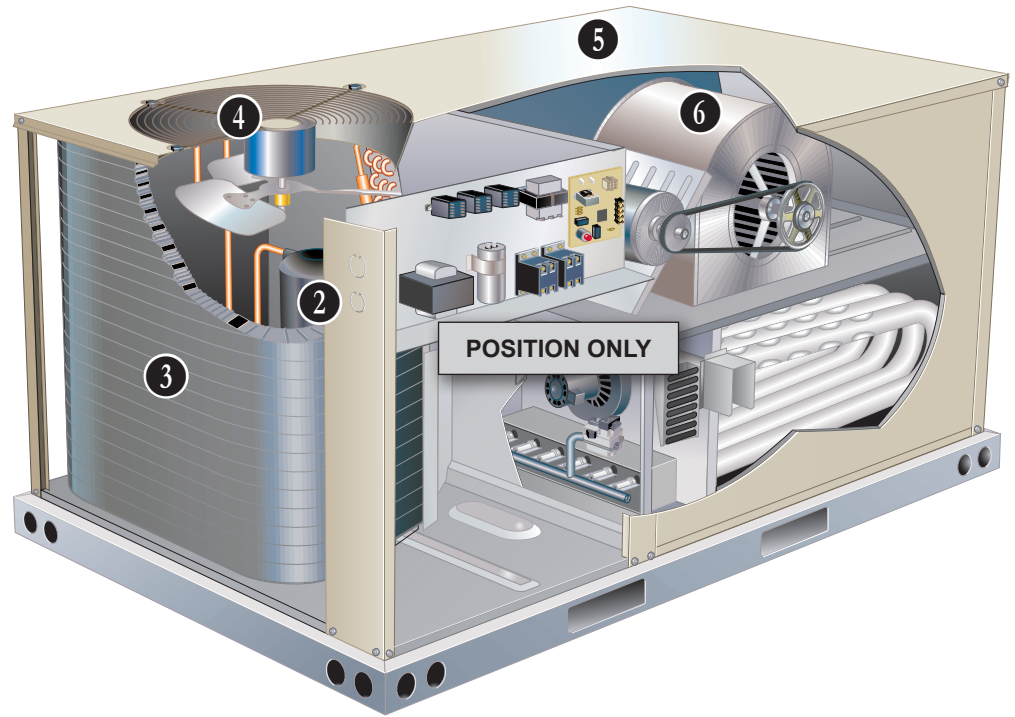

CONTENTS

Approvals And Warranty	3
Dimensions - Accessories	37
Dimensions - Unit	36
Electrical Data	31
Features And Benefits	3
High Altitude Derate	15
Model Number Identification.	1
Optional Conventional Temperature Control Systems	10
Options / Accessories	11
Outdoor Sound Data	29
Ratings	16
Specifications	13
- Direct Drive Models	13
- Belt Drive Models	14
- Conventional Gas Heat (Three Phase)	15
- Low NOx Gas Heat (Single And Three Phase)	15
Unit Clearances	34
Weight Data	35

APPROVALS AND WARRANTY

APPROVALS

- AHRI Certified to AHRI Standard 210/240-2023 (3 - 5 ton models)
- AHRI Standard 340/360-2023 (6 ton models)
- CSA listed
- Unit and components are ETL, NEC, and CEC bonded for grounding to meet safety standards for servicing
- All models are ASHRAE 90.1 compliant
- All models meet DOE 2023 energy efficiency standards and UL 60335-2-40 Refrigerant Detector Requirements
- ISO 9001 Registered Manufacturing Quality System

California Only

- These gas units do not meet the South Coast Air Quality Management District (SCAQMD) Rule 1111 and San Joaquin Valley Air Pollution Control District (SJVAPCD) Rule 4905 NOx emission limit (14 ng/J) and cannot be installed within the SCAQMD and SJVAPCD areas
- These gas units are approved by the California Energy Commission and meets California Nitrogen Oxides Standard (NOx) limits of 40 ng/J

WARRANTY

- Aluminized steel heat exchanger - Limited ten years
- Stainless steel heat exchanger (optional) - Limited fifteen years
- Compressors - Limited five years
- Eco-Last™ Coil System - Limited three years
- High Performance Economizers (optional) - Limited five years
- All other covered components - Limited one year

FEATURES AND BENEFITS

HEATING SYSTEM

- Aluminized steel inshot burners
- Direct spark ignition
- Electronic flame sensor
- Combustion air inducer
- Redundant automatic single or dual stage gas valve with manual shut-off

1 Heat Exchanger

- Tubular construction
- Aluminized steel
- Life cycle tested

NOTE - Stainless Steel Heat Exchanger is required if mixed air temperature is below 45°F.

Electronic Pilot Ignition

- Electronic spark igniter provides positive direct ignition of burners on each operating cycle
- System permits main gas valve to stay open only when the burners are proven to be lit
- Should a loss of flame occur, the gas valve closes, shutting off the gas to the burners
- Ignition module has LED to indicate status and aid in troubleshooting
- Watchguard circuit on module automatically resets ignition controls after one hour of continuous thermostat demand after unit lockout, eliminating nuisance service calls

Limit Controls

- Redundant limit controls with fixed temperature setting
- Protect heat exchanger and other components from overheating

Safety Switches

- Flame roll-out switch
- Flame sensor and combustion air inducer proving switch protect system operation

Low NOx Models

- All single phase models are available in low NOx versions (40 ng/J)

Required Selections

Gas Input Choice - Order one:

- Standard Gas Heat (1 Stage) 65,000 Btuh (Low NOx only)
- Medium Gas Heat (1 Stage) 108,000 Btuh
- High Gas Heat (2 Stage) 113,000/150,000 Btuh

Conventional or Low NOx

- Select conventional Gas Heat or Low NOx (40 ng/J) Gas Heat option for Medium or High Gas Heat (three phase models only)

NOTE - All single phase models are furnished with Low NOx (40 ng/J) gas heat.

FEATURES AND BENEFITS

HEATING SYSTEM (continued)

Options/Accessories

Field Installed

LPG/Propane Kits

- Conversion kit to field change over units from Natural Gas to LPG/Propane

Vertical Vent Extension Kit

- Use to exhaust flue gases vertically above unit
- Required when unit vent is too close to fresh air intakes per building codes
- Also prevents ice formation on intake louvers

COOLING SYSTEM

- Designed to maximize sensible and latent cooling performance at design conditions
- System can operate from 35°F to 125°F without any additional controls

R-454B Refrigerant

- Low GWP (Global Warming Potential)
- Zero ODP (Ozone Depletion Potential)
- Low Toxicity/Lower Flammability - A2L
- Unit is factory pre-charged

2 Single-Stage Scroll Compressor (036 through 060 Models)

- Resiliently mounted on rubber grommets for quiet operation
- Scroll compressor for high performance, reliability and quiet operation

Two-Stage Compressor (074 Models)

- Two-stage scroll compressors for increased part load efficiency, high performance, reliability and quiet operation
- Resiliently mounted on rubber grommets for quiet operation

Compressor Crankcase Heater

- Protects against refrigerant migration that can occur during low ambient operation or during extended off cycles

Thermal Expansion Valve

- Ensures optimal performance throughout the application range.
- Removable element head

Filter/Drier

- High capacity filter/drier protects the system from dirt and moisture

High Pressure Switch

- Protects the compressor from overload conditions such as dirty condenser coils, blocked refrigerant flow or loss of outdoor fan operation

Low Pressure Switch

- Protects the compressor from low pressure conditions such as low refrigerant charge or low/no airflow

3 Eco-Last™ Coil System

- Condenser and evaporator coil
- Lightweight, all aluminum brazed fin construction
- Constructed of three components:
 - A flat extrusion tube
 - Fins in-between the flat extrusion tube
 - Two refrigerant manifolds

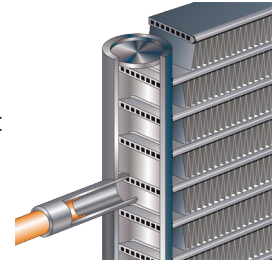

Eco-Last™ Coil System Features:

- Improved heat transfer performance due to high primary surface area (flat tubes) versus secondary surface (fins)
- Smaller internal volume (reduced refrigerant charge)
- High durability
- All aluminum construction
- Fewer brazed joints
- Compact design
- Reduced unit weight
- Easy maintenance/cleaning
- Mounting brackets with rubber inserts secure coil to unit providing vibration dampening and corrosion protection

Antimicrobial Condensate Drain Pan

- Composite pan, sloped to meet drainage requirements of ASHRAE 62.1
- Antimicrobial additive resists growth of mold and mildew on drain pan, which improves indoor air quality and reduces drain line blockage
- End drain connection

4 Outdoor Coil Fan Motor

- Thermal overload protected
- Totally enclosed
- Permanently lubricated bearings
- Shaft down
- Fan guard mount

Outdoor Coil Fan Guard

- PVC coated fan guard furnished

Required Selections

Cooling Capacity

- Specify nominal cooling capacity

FEATURES AND BENEFITS

COOLING SYSTEM (continued)

Options/Accessories

Field Installed

Condensate Drain Trap

- Available in copper or PVC

Drain Pan Overflow Switch

- Monitors condensate level in drain pan
- Shuts down unit if drain becomes clogged

Low Ambient Kit (0°F)

- Cycles the outdoor fans while allowing compressor operation in the cooling cycle
- Intermittent fan operation allows the system to operate without icing the evaporator coil and losing capacity
- Designed for use in ambient temperatures no lower than 0°F

NOTE - A crankcase heater must be installed on the compressor.

LOW GWP REFRIGERANT DETECTION SYSTEM (RDS)

- Complies with UL 60335-2-40 approved standard
- Required for all systems using R-454B refrigerant
- Factory installed on all units
- Consists of a refrigerant detection sensor(s) and a mitigation control
- Ensures safe operation for systems equipped with R-454B refrigerant
- Sensor(s) monitors indoor coil area for R-454B refrigerant
- If R-454B refrigerant is detected the refrigerant detection system will prevent compressor and heating operation until R-454B refrigerant is no longer detected
- Refrigeration detection system energizes blower if any R-454B refrigerant is detected to mitigate any concentrations of refrigerant from the unit and the system

CABINET

Construction

- 5 • Heavy-gauge steel panels
- Full perimeter heavy-gauge galvanized steel base rail
- Base rails have rigging holes
- Three sides of the base rail have forklift slots
- Raised edges around duct and power entry openings in the bottom of the unit for water protection

Airflow Choice

- Units are shipped in downflow (vertical) return air flow configuration

NOTE - Units can be field converted to horizontal airflow.

Power Entry

- Electrical lines can be routed through the unit base or through horizontal access knock-outs

NOTE - Optional Bottom Power Entry Kit is available.

Exterior Panels

- Constructed of heavy-gauge, galvanized steel
- Textured pre-paint with polyurethane finish
- Cyclic salt fog and UV exposure up to 1,680 hours per ASTM D5894

Insulation

- Fully insulated with non-hygroscopic fiberglass insulation (conditioned areas)

Access Panels

- Compressor
- Heating
- Controls
- Blower
- Air filter/economizer section

Options/Accessories

Field Installed

Combination Coil/Hail Guards

- Heavy gauge steel frame
- Painted to match cabinet
- Expanded metal mesh protects outdoor coil

FEATURES AND BENEFITS

CONTROLS

Compressor Monitor Control

- Anti-short cycle control (5 minutes)
- High and low pressure switch monitoring with five-strike lockout protection
- LEDs for diagnostic and troubleshooting

Refrigerant Detection System (RDS) Control

- Monitors leak detection sensor
- Terminal strip for thermostat, float switch and RDS alarm connections
- LED for power and sensor status

24V Transformer

- For all control voltage
- Resettable pop-up fuse

Options/Accessories

Smoke Detectors

NOTE - Smoke detectors are not available and must be field provided by installer.

Commercial Control Systems

Thermostats

- Control system and thermostat options, see page 10

BLOWER

A wide selection of supply air blower options are available to meet a variety of air flow requirements

Variable-Speed ECM Direct Drive Motor

- 036, 048 and 060 models

Belt Drive Blower Motor

- Overload protected
- Ball bearings
- Belt drive motors are offered on all models and are available in several different sizes to maximize air performance
- Two-speed belt drive motor (low static/high static) is available on 074 models

6 Supply Air Blower

- Forward curved blades
- Blower wheel statically and dynamically balanced.
- Ball bearings
- Adjustable pulley (allows speed change)

Single Zone VAV Supply Fan Operation (2-Speed Blower Units)

- Single Zone VAV Supply Fan stages the amount of airflow according to compressor stages, heating demand and ventilation demand
- Units utilize a 2-Speed induction blower motor to stage the supply air blower airflow
 - Low Speed - 1st Stage cooling, and ventilation mode
 - High Speed - 2nd Stage (Full load) cooling and all heat modes
- High speed blower operation is set by adjusting the motor pulley to deliver the desired air volume

NOTE: Ventilation speed is same as low speed for improved energy savings. Lower operating costs are obtained when the blower is operated on lower speeds.

NOTE: Part-load airflow in cooling mode should not be set below 220 cfm/nominal full load ton to reduce the risk of evaporator coil freeze-up.

Single Zone VAV Supply Fan Sequence of Operation (2-Speed Blower Units)

- Blower operates in low speed with (G) demand
- Blower operates in low speed for mechanical cooling (Y1)
- Blower operates in high-speed for any other mode: (Y1+Y2), and heating
- Economizer damper minimum position is fully closed in unoccupied mode
- In occupied mode, the economizer damper minimum position is determined by the economizer minimum position of the potentiometer
- When Outdoor air is not suitable the blower operates on low speed for (Y1) and switches to high-speed for (Y1+Y2)
- In free cooling, the blower operates on low speed for (Y1)

NOTE: Economizer position is determined by mixed air sensor when unit is in free cooling.

Required Selections

- Specify ECM or Belt Drive Blower Motor

Belt Drive Supply Air Blower

- Order blower motor horsepower and drive kit number required when base unit is ordered
- See Drive Kit Specifications Table

OPTIONS / ACCESSORIES

ELECTRICAL

Marked & Color-Coded Wiring

- All electrical wiring is color-coded and marked to identify which components it is connecting

Electrical Plugs

- Positive connection electrical plugs are used to connect common accessories or maintenance parts for easy removal or installation

Required Selections

Voltage Choice

- Specify when ordering base unit

Field Installed

Bottom Power Entry Kit

- Kit reduces the number of penetrations in the roof
- Kit includes bulkhead connectors to provides power and control wiring routing through the roof curb

INDOOR AIR QUALITY

Air Filters

- Disposable 2 inch MERV 4 filters furnished as standard

Options/Accessories

Field Installed

Indoor Air Quality (CO₂) Sensor

- Monitors CO₂ levels adjusts economizer dampers as needed for Demand Control Ventilation

ECONOMIZER

Economizer (Downflow or Horizontal) (Standard and High Performance Common Features)

- Outdoor Air Hood is furnished
- Includes Barometric Relief Dampers with Exhaust Hood
- Barometric Relief Dampers allow relief of excess air,
- Aluminum blade dampers prevent blow back and outdoor air infiltration during off cycle
- Exhaust hood with bird screen furnished
- Demand Control Ventilation (DCV) ready using optional CO₂ sensors
- Single temperature control is furnished with Economizer
- Outdoor air sensor enables Economizer if the outdoor temperature is less than the setpoint of the control

NOTE - Horizontal Economizer is field installed only.

Field Installed

Standard Economizer Features (Not for Title 24)

- Gear-driven action
- Return air and outdoor air dampers
- Plug-in connections to unit
- Nylon bearings
- Neoprene seals
- 24-volt
- Fully-modulating spring return motor

Standard Economizer Control Module

The Standard Economizer Control Module can be adjusted to operate based on outdoor air temperatures



Economizer Controls:

- **Damper Minimum Position** - Can be set lower than traditional minimum air requirements resulting in cost savings
- **IAQ Sensor** - Signals dampers to modulate and maintain 55°F when CO₂ is higher than the CO₂ setpoint
- **Demand Control Ventilation (DCV) LED** - A steady green Demand Control Ventilation LED indicates the IAQ reading is higher than setpoint and requires more fresh air
- **Free Cool LED** - A steady green LED indicates outdoor air is suitable for free cooling

NOTE - Free Cooling runs when outdoor air temperature is lower than the set temperature on the economizer control.

NOTE: The Free Cooling default setting for outdoor air temperature sensor is 55°F.

Factory or Field Installed

High Performance Economizer

- Approved for California Title 24 building standards
- Low leakage dampers are Air Movement and Control Association International (AMCA) Class 1A Certified - Maximum 3 cfm per sq. ft. leakage at 1 in. w.g.
- ASHRAE 90.1 compliant
- Factory installed Economizer can be ordered with two exhaust options:
 - Barometric Relief Dampers
 - No Exhaust

Features:

- Linked damper action
- High torque 24-volt fully-modulating spring return damper motor
- Return air and outdoor air dampers
- Plug-in connections to unit

OPTIONS / ACCESSORIES

ECONOMIZER (continued)

NOTE - High Performance Economizers are not approved for use with differential enthalpy controls in Title 24 applications.

- Combination Outdoor Air/Exhaust Hood is furnished
- Field installed Economizer includes Barometric Relief Dampers with Combination Outdoor Air/Exhaust Hood
- Occupied/Unoccupied mode with field furnished setback thermostat
- Demand Control Ventilation (DCV) ready using optional CO₂ sensors
- Mixed Air Sensor is furnished for field installation in the rooftop unit

NOTE - Mixed Air Sensor is factory installed when Economizer is factory installed.

- Single sensible sensor is furnished with field installed Economizer and enables economizer operation if the outdoor temperature is less than the setpoint of the control
- Barometric Relief Dampers allow relief of excess air, dampers prevent blow back and outdoor air infiltration during off cycle, bird screen furnished

NOTE - Barometric Relief Dampers are required when Economizer is factory installed with field installed Power Exhaust Fan option. See Power Exhaust Fan section and Options/Accessories table.

NOTE - Horizontal Barometric Dampers are required for horizontal Economizer applications and must be ordered separately.

High Performance Economizer Control Module

- Provides inputs and outputs to control economizer based on parameter settings
- Free cooling based on single dry bulb temperature, or combination temperature + humidity sensors
- Automatic switchover for different control modes
- Parameter settings based on climate zone, using GPS functionality in the Climatix Mobile application
- LED indication for free cooling operation, sensor operation and damper operation
- Quick installation and easy commissioning with the Climatix Mobile App on a mobile device

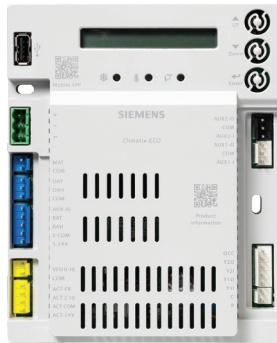

NOTE - WLAN Stick is required for App connection to module(s).

- Module displays any alarm messages (fault detection and diagnostics) as an aid in troubleshooting
- RS585 port for BACnet MSTP or Modbus RTU communication

- USB port for firmware updates and WLAN connection for setup and commissioning
- QR codes on module for quick access to download Climatix Mobile App and user documentation
- User Interface for normal operation, parameter setup and alarm notifications with an LCD display and three operation buttons:
 1. **Up Button** - Move to the previous value, step or category
 2. **Down Button** - Move to the next value, step or category
 3. **Enter Button** -
 - Press to edit the current value or option
 - Press to confirm a newly selected value or option
 - Press Enter + Up to jump up one category
 - Press Enter + Down to jump down one category

NOTE - The Free Cooling setpoint for Title 24 applications must be set based on the Climate Zone where the system is installed. See Section 140.4 "Prescriptive Requirements for Space Conditioning Systems" of the California Energy Commission's 2022 Building Energy Efficiency Standards.

NOTE - Refer to Installation Instructions for complete setup information and menu parameters available.

Field Installed

Single Enthalpy Temperature Control

- Outdoor air enthalpy sensor enables Economizer if the outdoor enthalpy is less than the setpoint of the control

NOTE - The factory installed economizer option comes preset for Single Enthalpy control but can be field converted to Single Sensible Temperature control by changing a parameter on the economizer control module.

Differential Enthalpy Control (Not for Title 24)

- Order one for factory installed economizer
- Order two for field installed economizer
 - One is field installed in the return air section
 - One in the outdoor air section
- Allows the economizer control board to select between outdoor air or return air, whichever has lower enthalpy

WLAN Stick

- Required for Climatix Mobile App usage
- Plugs into USB port on Module to provide a temporary WLAN connection for setup, commissioning and servicing

NOTE - Only one WLAN Stick is required and can be used on multiple modules.

OPTIONS / ACCESSORIES

EXHAUST

Field Installed

Power Exhaust Fan - Downflow or Horizontal

- Installs external to unit for applications with Economizer option
- Provides exhaust air pressure relief
- Interlocked to run when supply air blower is operating
- Fan runs when outdoor air dampers are 50% open (adjustable)
- Motor is overload protected
- Fan is 12 in. diameter
- Five fan blades
- 1/2 HP motor.

OUTDOOR AIR

Field Installed

Outdoor Air Dampers - Downflow

- Single blade damper
- 0 to 25% (fixed) outdoor air adjustable
- Installs in unit
- Motorized model features fully modulating spring return damper motor with plug-in connection
- Manual model features a slide damper

NOTE - Maximum mixed air temperature in cooling mode is 100°F.

ROOF CURBS

Field Installed

Hybrid Roof Curbs, Downflow

- Nailer strip furnished; mates to unit
- US National Roofing Contractors approved
- Shipped knocked down
- Interlocking tabs fasten corners together
- No tools required for assembly
- Can also be fastened together with furnished hardware
- Available in 8, 14, 18, and 24 inch heights

Adaptor Curbs (not shown)

- Curbs are regionally sourced
- Dimensions will vary based upon the source

NOTE - Contact your local sales representative for a detailed cut sheet with applicable dimensions.

CEILING DIFFUSERS

Field Installed

- Flush or Step-Down
- White powder coat finish on diffuser face and grilles
- Insulated UL listed duct liner
- Diffuser box has collars for duct connection
- Step-down diffusers have double deflection blades
- Flush diffusers have fixed blades
- Provisions for suspending
- Internally sealed to prevent recirculation
- Removable return air grille
- Adapts to T-bar ceiling grids or plaster ceilings

Transitions (Supply and Return)

NOTE - Ceiling Diffuser Transitions are not furnished and must be field fabricated.

OPTIONAL CONVENTIONAL TEMPERATURE CONTROL SYSTEMS

CS7500 Commercial 7-Day Programmable Thermostat



- Premium Universal Thermostat
- Full Color Touchscreen Interface
- Up To 4 Heat / 3 Cool
- Built-In Sensors For Temperature and Humidity
- Remote Sensors Options For Temperature, Discharge Air, Outdoor Air
- 5-2 or 7-Day Scheduling
- Smooth Setback Recovery
- Heat/Cool Auto-Changeover
- FDD, ASHRAE, IECC Compliant

CS3000 Commercial 5-2 Day Programmable Thermostat

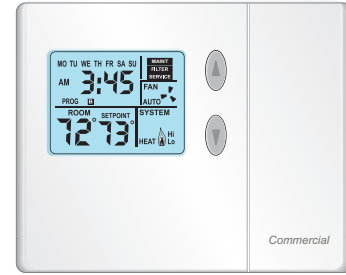

- Conventional Multi-Stage Thermostat
- Intuitive Display
- Push-Button Operation
- Up To 2 Heat / 2 Cool
- Built-In Temperature Sensor
- Remote Temperature Sensing
- Up to 5-2 Day Scheduling
- Smooth Setback Recovery
- Heat/Cool Auto-changeover

BACnet Compatible Thermostat With Reheat



- 7-Day Programmable
- For units with or without Humiditrol®
- BTL listed MS/TP ensures compatibility with any BACnet system
- Built-in control programs for conventional and heat pump applications
- Conventional systems up to 3-stage heat and 3-stage cool
- Heat pumps with 1 or 2 compressors and up to 2-stage auxiliary heat
- On-board temperature and humidity sensor
- Multiple configurable inputs and outputs enable advanced control strategies
- Set-up Wizard enables rapid system configuration
- No special tools required for installation or commissioning
- Seven-day (2, 4 or 6 event) occupancy scheduling per day
- Backlit 5-inch LCD touchscreen

Description	Order Number
CS7500 Commercial 7-Day Programmable Thermostat	
CS7500 7-Day Thermostat	24K41
Sensors/	¹ Remote non-adjustable wall-mount 20k 47W36
Accessories	¹ Remote non-adjustable wall-mount 10k 47W37
	Remote non-adjustable discharge air (duct mount) 19L22
	Outdoor temperature sensor X2658
CS3000 5-2 Day Programmable Thermostat	
CS3000 5-2 Day Thermostat	11Y05
Sensor/	Remote non-adjustable wall mount 10k averaging 47W37
Accessories	Thermostat wall mounting plate X2659
BACnet 7-Day Programmable Thermostat	
BACnet	² 7-Day BACnet Thermostat 24C57
Controls	³ BACnet Module 16X70
⁴ BACnet	With Display 97W23
Room Sensors	Without Display 97W24
Universal Thermostat Guard with Lock (clear)	
Inside Dimensions (H x W x D)	5-7/8 x 8-3/8 x 3 in. 39P21

¹ Remote wall-mount sensors can be applied in any of the following combinations:
 One Sensor - (1) 47W36, Two Sensors - (2) 47W37, Three Sensors - (2) 47W36 and (1) 47W37
 Four Sensors - (4) 47W36, Five Sensors - (3) 47W36 and (2) 47W37

² BACnet Thermostat (24C57) will control units with and without the dehumidification option. If there is a mix of units equipped with and without dehumidification on the same site, this thermostat can be used for all units if suitable.

³ Not compatible with units equipped with dehumidification option.

⁴ Only compatible with BACnet Module (16X70).

OPTIONS / ACCESSORIES

Item	Order Number	Size				
		036	048	060	074	
COOLING SYSTEM						
Condensate Drain Trap	PVC	22H54	X	X	X	X
	Copper	76W27	X	X	X	X
Drain Pan Overflow Switch		38A64	X	X	X	X
Low Ambient Kit		99W67	X	X	X	X
HEATING SYSTEM						
Conventional Gas Heat	Medium One-Stage - 108 kBtuh input (3 phase)	Factory	O	O	O	O
	High Two-Stage - 113/150 kBtuh input (3 phase)	Factory		O	O	O
¹ Low NOx Gas Heat	Standard One-Stage - 65 kBtuh input (1 and 3 phase)	Factory	O	O	³ O	O
	Medium One-Stage - 108 kBtuh input (1 and 3 phase)	Factory	O	O		
	High Two-Stage - 113/150 kBtuh input (1 and 3 phase)	Factory		² O	O	O
LPG/Propane Conversion Kits	One-Stage Heat	21Z22	X	X	X	X
	Two-Stage heat	21Z23	X	X	X	X
Stainless Steel Heat Exchanger		Factory	O	O	O	O
Vertical Vent Extension Kit		31W62	X	X	X	X
BLOWER - SUPPLY AIR						
Motors	Direct Drive (ECM) - 0.50 HP (208/230V-1ph, 208/230V-3ph)	Factory	O			
	Direct Drive (ECM) - 0.75 HP (208/230V-1ph, 208/230V-3ph)	Factory		O		
	Direct Drive (ECM) - 1.0 HP (208/230V-1ph, 208/230V-3ph)	Factory			O	
	Belt Drive - 1 HP (208/230V, 460V, 575V-3ph) Standard Efficiency	Factory	O	O		
	Belt Drive - 1.5 HP (208/230V, 460V, 575V-3ph) Standard Efficiency	Factory		O	O	
	Belt Drive - 2 HP (208/230V, 460V, 575V-3ph) (2 Speed)	Factory				O
Drive Kits See Blower Data Tables for selection	Kit #ZA01 - 678-1035 rpm	Factory	O			
	Kit #ZA02 - 803-1226 rpm	Factory		O		
	Kit #ZA03 - 906-1383 rpm	Factory			O	
	Kit #ZA04 - 964-1471 rpm	Factory	O			
	Kit #ZA06 - 1262-1634 rpm	Factory			O	
	Kit #ZAA02 - 632-875 rpm	Factory				O
	Kit #ZAA03 - 798-1105 rpm	Factory				O
	Kit #ZAA04 - 921-1226 rpm	Factory				O
CABINET						
Coil/Hail Guards		12X19	X	X		
		12X20			X	X
ELECTRICAL						
Voltage 60 Hz	208/230V - 1 phase	Factory	O	O	O	
	208/230V - 3 phase	Factory	O	O	O	O
	460V - 3 phase	Factory	O	O	O	O
	575V - 3 phase	Factory	O	O	O	O
Bottom Power Entry Kit		98W08	X	X	X	X

¹ Low NOx is furnished with all single phase models, optional for three phase models with Medium or High Gas Heat.

² High Gas Heat is 3-phase only with 048 models.

³ Standard Gas Heat is 3-phase only with 060 models.

NOTE - Order numbers shown are for ordering field installed accessories.

OX - Configure To Order (Factory Installed) or Field Installed

O = Configure To Order (Factory Installed)

X = Field Installed

OPTIONS / ACCESSORIES

Item	Order Number	Size				
		036	048	060	074	
ECONOMIZERS						
Standard Economizer With Outdoor Air Hood (Not for Title 24)						
Standard Economizer (Downflow) Includes Barometric Relief Dampers and Exhaust Hood	14D94	X	X	X	X	
Standard Economizer (Horizontal) Includes Barometric Relief Dampers and Exhaust Hood	14D92	X	X	X	X	
Standard Economizer Controls (Not for Title 24)						
Single Enthalpy Control	21Z09	X	X	X	X	
High Performance Economizer With Outdoor Air Hood (Approved for California Title 24 Building Standards / AMCA Class 1A Certified)						
High Performance Economizer (Downflow) Includes Barometric Exhaust Dampers and Exhaust Hood	24J59	OX	OX	OX	OX	
High Performance Economizer (Horizontal) Includes Barometric Exhaust Dampers and Exhaust Hood	24J60	X	X	X	X	
Economizer Controls						
Single Enthalpy Control	24G11	X	X	X	X	
Economizer Accessories						
WLAN Stick (For High Performance Economizer only)	23K58	X	X	X	X	
OUTDOOR AIR						
Outdoor Air Dampers With Outdoor Air Hood						
Motorized	15D19	X	X	X	X	
Manual	15D20	X	X	X	X	
POWER EXHAUST FAN						
Standard Static (Downflow)	208/230V-1 or 3ph	21E01	X	X	X	X
	460V-3ph	23E01	X	X	X	X
Standard Static (Horizontal)	208/230V-1 or 3ph	24E01	X	X	X	X
	460V-3ph	28E01	X	X	X	X
575V Transformer Kit	575V-3ph	59E02	X	X	X	X
NOTE - Order 575V Transformer Kit with 208/230V Power Exhaust Fan for 575V applications.						
INDOOR AIR QUALITY						
Indoor Air Quality (CO₂) Sensors						
Sensor - Wall-mount, off-white plastic cover with LCD display		77N39	X	X	X	X
Sensor - Wall-mount, black plastic case, no display, rated for plenum mounting		87N54	X	X	X	X
CO ₂ Sensor Duct Mounting Kit - for downflow applications		85L43	X	X	X	X
Aspiration Box - for duct mounting non-plenum rated CO ₂ sensor (77N39)		90N43	X	X	X	X
ROOF CURBS						
Hybrid Roof Curbs, Downflow						
8 in. height		11F76	X	X	X	X
14 in. height		11F77	X	X	X	X
18 in. height		11F78	X	X	X	X
24 in. height		11F79	X	X	X	X
CEILING DIFFUSERS						
Step-Down - Order one	RTD9-65S	13K60	X	X	X	
	RTD11-95S	13K61				X
Flush - Order one	FD9-65S	13K55	X	X	X	
	FD11-95S	13K56				X

NOTE - Ceiling Diffuser Transitions are not furnished and must be field fabricated.

NOTE - Order numbers shown are for ordering field installed accessories.

OX - Configure To Order (Factory Installed) or Field Installed

O = Configure To Order (Factory Installed)

X = Field Installed

SPECIFICATIONS		DIRECT DRIVE MODELS		
Model		ZGD036S5E	ZGD048S5E	ZGD060S5E
Nominal Tonnage		3	4	5
Efficiency Type		Standard	Standard	Standard
Blower Type		ECM Direct Drive	ECM Direct Drive	ECM Direct Drive
Cooling Performance	Gross Cooling Capacity (Btuh)	36,200	46,700	57,000
	¹ Net Cooling Capacity (Btuh)	35,000	45,500	57,000
	¹ AHRI Rated Air Flow (cfm)	1190	1380	1725
	¹ SEER2 (Btuh/Watt)	13.4	13.4	13.4
	¹ EER2 (Btuh/Watt)	10.6	10.6	10.6
	Total Unit Power (kW)	3.0	4.1	5.0
Sound Rating Number	dBA	78	80	78
Refrigerant	Type	R-454B	R-454B	R-454B
	Charge Furnished	4 lbs. 1 oz.	4 lbs. 4 oz.	4 lbs. 10 oz.
Gas Heating Options		See page 15		
Compressor Type (number)		Scroll (1)	Scroll (1)	Scroll (1)
Outdoor Coil	Net face area - ft. ²	15.2	15.2	19.9
	Rows	1	1	1
	Fins - in.	23	23	23
Outdoor Coil Fan	Motor HP (number and type)	1/4 (1 ECM)	1/4 (1 ECM)	1/4 (1 ECM)
	Rpm	825	825	825
	Watts	315	315	315
	Diameter (Number) - in.	(1) 22	(1) 22	(1) 22
	Blades	4	4	4
	Total air volume - cfm	3700	3700	3700
Indoor Coil	Net face area - ft. ²	7.2	7.2	7.2
	Rows	1	1	1
	Fins - in.	18	18	18
	Condensate drain size (NPT) - in.	(1) 3/4	(1) 3/4	(1) 3/4
	Expansion device type	Balanced Port Thermostatic Expansion Valve		
Indoor Blower	Nominal Motor HP	0.50 (ECM)	0.75 (ECM)	1 (ECM)
	Wheel (Number) diameter x width - in.	(1) 10 x 10	(1) 10 x 10	(1) 11 x 10
Filters	Type	Disposable		
	Number and size - in.	(4) 14 x 20 x 2		(2) 16 x 20 x 2 (2) 20 x 20 x 2
Line voltage data (Volts-Phase-Hz)		208/230-1-60 208/230-3-60	208/230-1-60 208/230-3-60	208/230-1-60 208/230-3-60

NOTE - Net capacity includes evaporator blower motor heat deduction. Gross capacity does not include evaporator blower motor heat deduction.

¹ AHRI Certified to AHRI Standard 210/240: 95°F outdoor air temperature and 80°F db/67°F wb entering evaporator air; minimum external duct static pressure.

SPECIFICATIONS		BELT DRIVE MODELS			
Model		ZGD036S5B	ZGD048S5B	ZGD060S5B	ZGD074S5T
Nominal Tonnage		3	4	5	6
Efficiency Type		Standard	Standard	Standard	Standard
Blower Type		Single Speed Belt Drive	Single Speed Belt Drive	Single Speed Belt Drive	Two Speed Belt Drive
Cooling Performance	Gross Cooling Capacity (Btuh)	36,200	46,700	58,300	68,500
	¹ Net Cooling Capacity (Btuh)	35,000	45,500	57,000	67,000
	¹ AHRI Rated Air Flow (cfm)	1190	1380	1725	2200
	¹ SEER2 (Btuh/Watt)	13.4	13.4	13.4	---
	¹ EER2 (Btuh/Watt)	11.5	11.5	11.5	---
	¹ IEER (Btuh/Watt)	---	---	---	15.0
	¹ EER (Btuh/Watt)	---	---	---	11.0
	Total Unit Power (kW)	3.0	4.1	5.0	5.8
Sound Rating Number	dBA	78	80	78	84
Refrigerant	Type	R-454B	R-454B	R-454B	R-454B
	Charge Furnished	4 lbs. 1 oz.	4 lbs. 4 oz.	4 lbs. 10 oz.	6 lbs. 14 oz.
Gas Heating Options		See page 15			
Compressor Type (number)		Single-Stage Scroll (1)	Single-Stage Scroll (1)	Single-Stage Scroll (1)	Two-Stage Scroll (1)
Outdoor Coil	Net face area - ft. ²	15.2	15.2	19.9	19.9
	Rows	1	1	1	1
	Fins - in.	23	23	23	23
Outdoor Coil Fan	Motor HP	(1) 1/4	(1) 1/4	(1) 1/4	(1) 1/3
	Rpm	825	825	825	1075
	Watts	315	315	315	365
	Diameter (Number) - in.	(1) 22	(1) 22	(1) 22	(1) 22
	Blades	4	4	4	3
	Total air volume - cfm	3700	3700	3700	4270
Indoor Coil	Net face area - ft. ²	7.2	7.2	7.2	9.5
	Rows	1	1	1	1
	Fins - in.	18	18	18	18
	Condensate drain size (NPT) - in.	(1) 3/4	(1) 3/4	(1) 3/4	(1) 3/4
	Expansion device type	Balanced Port Thermostatic Expansion Valve			
² Indoor Blower & Drive Selection	Nominal Motor HP	1	1	1.5	2
	Maximum Usable Motor HP	1.15	1.15	1.7	2.3
	Drive Kits	Kit #ZA01 678-1035 rpm Kit #ZAA04 921-1228 rpm	Kit #ZA02 803-1226 rpm	Kit #ZA03 906-1383 rpm Kit #ZA06 1262-1634 rpm	Kit #ZAA02 632-875 rpm Kit #ZAA03 798-1105 rpm Kit #ZAA04 921-1228 rpm
	Wheel (Number) diameter x width - in.	(1) 10 x 10	(1) 10 x 10	(1) 10 x 10	(1) 15 x 9
Filters	Type	Disposable			
	Number and size - in.	(4) 14 x 20 x 2		(2) 16 x 20 x 2 (2) 20 x 20 x 2	
Line voltage data (Volts-Phase-Hz)		208/230-3-60 460-3-60 575-3-60	208/230-3-60 460-3-60 575-3-60	208/230-3-60 460-3-60 575-3-60	208/230-3-60 460-3-60 575-3-60

NOTE - Net capacity includes evaporator blower motor heat deduction. Gross capacity does not include evaporator blower motor heat deduction.

¹ AHRI Certified to AHRI Standard 210/240 or 340/360: 95°F outdoor air temperature and 80°F db/67°F wb entering evaporator air; minimum external duct static pressure.

² Using total air volume and system static pressure requirements determine from blower performance tables rpm and motor HP required. Maximum usable HP of motors furnished are shown. In Canada, nominal motor HP is also maximum usable motor HP output. If motors of comparable HP are used, be sure to keep within the service factor limitations outlined on the motor nameplate.

SPECIFICATIONS CONVENTIONAL GAS HEAT (THREE PHASE)

Size		036, 048, 060	074	048, 060	074
Heat Input Type		Medium (1 Stage)		High (2 Stage)	
Input Btuh	1st Stage	108,000		113,000	
	2nd Stage	---		150,000	
Output Btuh	1st Stage	86,000		90,000	
	2nd Stage	---		120,000	
Temperature Rise Range - °F	1st stage	35 - 65	20 - 50	30 - 60	25 - 55
	2nd Stage	---	---	45 - 75	35 - 65
Minimum air volume - cfm	Direct Drive (ECM)		N/A		N/A
	Belt Drive (1 Speed)		N/A		N/A
	Belt Drive (2 Speed)	N/A		N/A	
¹ Thermal Efficiency	Standard	80%	80%	80%	80%
Gas Supply Connections		1/2 in. NPT			
Recommended Gas Supply Pressure - Nat. / LPG		7 in.w.g. / 11 in.w.g.			
Gas Supply Pressure Range	Min./Max. (Natural)	4.5 - 10.5 in. w.g.			
	Min./Max. (LPG)	10.8 - 13.5 in. w.g.			

¹ Thermal Efficiency at full input.

SPECIFICATIONS LOW NOX GAS HEAT (SINGLE AND THREE PHASE)

Size		036, 048, ¹ 060	074	036, 048, 060	² 048, 060	074
Heat Input Type		Standard (1 Stage)		Medium (1 Stage)	High (2 Stage)	
Input Btuh	1st Stage	65,000		108,000	113,000	
	2nd Stage	---		---	150,000	
Output Btuh	1st Stage	52,000		87,000	92,000	
	2nd Stage	---		---	121,000	
Temperature Rise Range - °F	1st stage	15 - 45	5 - 35	35 - 65	30 - 60	25 - 55
	2nd Stage	---	---	---	45 - 75	35 - 65
Minimum air volume - cfm	Direct Drive (ECM)		N/A			N/A
	Belt Drive (1 Speed)		N/A			N/A
	Belt Drive (2 Speed)	N/A			N/A	
³ AFUE (single phase)		81%	---	81%	81%	---
⁴ Thermal Efficiency (three phase)		81%	81%	81%	81%	81%
Gas Supply Connections		1/2 in. NPT				
Recommended Gas Supply Pressure - Nat. / LPG		7 in.w.g. / 11 in.w.g.				
Gas Supply Pressure Range	Min./Max. (Natural)	4.5 - 10.5 in. w.g.				
	Min./Max. (LPG)	10.8 - 13.5 in. w.g.				

¹ Standard Gas Heat is 3-phase only with 060 models.

² High Gas Heat is 3-phase only with 048 models.

³ Annual Fuel Utilization Efficiency based on U.S. DOE test procedures and FTC labeling regulations - 1 phase models only.

⁴ Thermal Efficiency at full input.

HIGH ALTITUDE DERATE

NOTE - Units may be installed at altitudes up to 2000 feet above sea level without any modifications.

At altitudes above 2000 feet units must be derated to match gas manifold pressures shown in table below.

At altitudes above 4500 feet unit must be derated 2% for each 1000 feet above sea level.

NOTE - This is the only permissible derate for these units.

Refer to the Installation Instructions for more detailed information.

Heat Input Type	Altitude Feet	Gas Manifold Pressure in. w.g.		Input Rate (Btuh)
		Natural Gas	LPG/ Propane	
Standard (1 stage)	2001 - 4500	1.7 / 3.0	5.9 / 9.0	60,000
Medium (1 stage)	2001 - 4500	1.7 / 3.0	5.9 / 9.0	100,000
Medium (2 stage)	2001 - 4500	1.7 / 3.0	5.9 / 9.0	75,000 / 100,000
High (2 stage)	2001 - 4500	1.7 / 3.0	5.9 / 9.0	104,000 / 139,000

RATINGS

NOTE – For Temperatures and Capacities not shown in tables, see bulletin – Cooling Unit Rating Table Correction Factor Data in Miscellaneous Engineering Data section.

3 TON - ZGD036S5

Entering Wet Bulb Temperature	Total Air Volume	Outdoor Air Temperature Entering Outdoor Coil																				
		85°F						95°F					105°F					115°F				
		Total Cool Cap.	Comp. Motor Input	Sensible To Total Ratio (S/T)			Total Cool Cap.	Comp. Motor Input	Sensible To Total Ratio (S/T)			Total Cool Cap.	Comp. Motor Input	Sensible To Total Ratio (S/T)			Total Cool Cap.	Comp. Motor Input	Sensible To Total Ratio (S/T)			
				Dry Bulb					Dry Bulb					Dry Bulb					Dry Bulb			
cfm	kBtuh	kW	75°F	80°F	85°F	kBtuh	kW	75°F	80°F	85°F	kBtuh	kW	75°F	80°F	85°F	kBtuh	kW	75°F	80°F	85°F		
63°F	960	34.5	2.06	0.70	0.84	0.99	32.4	2.31	0.71	0.86	1.00	30.2	2.60	0.73	0.90	1.00	27.7	2.94	0.75	0.94	1.00	
	1200	36.3	2.07	0.75	0.93	1.00	34.2	2.32	0.77	0.96	1.00	31.8	2.61	0.79	0.99	1.00	29.3	2.94	0.83	1.00	1.00	
	1440	37.8	2.07	0.80	1.00	1.00	35.6	2.33	0.83	1.00	1.00	33.5	2.62	0.86	1.00	1.00	30.9	2.95	0.91	1.00	1.00	
67°F	960	36.7	2.07	0.55	0.67	0.80	34.5	2.32	0.56	0.69	0.83	32.1	2.61	0.57	0.71	0.86	29.5	2.95	0.58	0.73	0.90	
	1200	38.6	2.08	0.58	0.73	0.89	36.2	2.33	0.59	0.75	0.92	33.6	2.62	0.60	0.77	0.95	30.8	2.95	0.62	0.81	1.00	
	1440	39.9	2.09	0.61	0.78	0.97	37.4	2.34	0.63	0.81	0.99	34.7	2.63	0.65	0.84	1.00	31.8	2.96	0.66	0.89	1.00	
71°F	960	38.7	2.08	0.42	0.54	0.65	36.5	2.33	0.41	0.54	0.67	34.0	2.62	0.41	0.55	0.69	31.3	2.95	0.42	0.57	0.71	
	1200	40.7	2.09	0.43	0.57	0.71	38.3	2.35	0.43	0.58	0.73	35.6	2.63	0.43	0.59	0.75	32.7	2.96	0.44	0.61	0.78	
	1440	42.1	2.10	0.45	0.60	0.76	39.6	2.35	0.44	0.61	0.78	36.9	2.64	0.45	0.64	0.82	33.7	2.97	0.46	0.65	0.86	

4 TON - ZGD048S5

Entering Wet Bulb Temperature	Total Air Volume	Outdoor Air Temperature Entering Outdoor Coil																				
		85°F						95°F					105°F					115°F				
		Total Cool Cap.	Comp. Motor Input	Sensible To Total Ratio (S/T)			Total Cool Cap.	Comp. Motor Input	Sensible To Total Ratio (S/T)			Total Cool Cap.	Comp. Motor Input	Sensible To Total Ratio (S/T)			Total Cool Cap.	Comp. Motor Input	Sensible To Total Ratio (S/T)			
				Dry Bulb					Dry Bulb					Dry Bulb					Dry Bulb			
cfm	kBtuh	kW	75°F	80°F	85°F	kBtuh	kW	75°F	80°F	85°F	kBtuh	kW	75°F	80°F	85°F	kBtuh	kW	75°F	80°F	85°F		
63°F	1280	45.2	2.93	0.72	0.85	0.99	43.8	3.30	0.74	0.88	1.00	42.3	3.74	0.76	0.91	1.00	40.6	4.25	0.79	0.95	1.00	
	1600	47.0	2.94	0.76	0.94	1.00	45.4	3.32	0.79	0.97	1.00	43.7	3.76	0.82	1.00	1.00	42.1	4.27	0.85	1.00	1.00	
	1920	48.3	2.96	0.82	1.00	1.00	46.8	3.34	0.85	1.00	1.00	45.3	3.78	0.88	1.00	1.00	43.6	4.30	0.92	1.00	1.00	
67°F	1280	47.3	2.95	0.58	0.69	0.82	45.7	3.33	0.59	0.71	0.84	44.1	3.76	0.61	0.74	0.88	42.4	4.28	0.63	0.76	0.92	
	1600	49.2	2.97	0.60	0.74	0.90	47.4	3.35	0.62	0.76	0.93	45.6	3.79	0.64	0.79	0.97	43.6	4.30	0.66	0.83	1.00	
	1920	50.4	2.98	0.63	0.79	0.98	48.5	3.36	0.65	0.82	1.00	46.6	3.8	0.67	0.86	1.00	44.3	4.32	0.70	0.90	1.00	
71°F	1280	49.2	2.97	0.45	0.56	0.67	47.6	3.35	0.45	0.57	0.69	45.8	3.79	0.47	0.59	0.71	44.0	4.31	0.49	0.62	0.74	
	1600	51.2	2.99	0.45	0.59	0.72	49.4	3.38	0.47	0.61	0.74	47.5	3.82	0.48	0.63	0.77	45.2	4.34	0.50	0.65	0.80	
	1920	52.7	3.01	0.46	0.62	0.77	50.6	3.39	0.48	0.64	0.80	48.6	3.84	0.50	0.66	0.83	46.3	4.36	0.52	0.69	0.88	

5 TON - ZGD060S5

Entering Wet Bulb Temperature	Total Air Volume	Outdoor Air Temperature Entering Outdoor Coil																				
		85°F						95°F					105°F					115°F				
		Total Cool Cap.	Comp. Motor Input	Sensible To Total Ratio (S/T)			Total Cool Cap.	Comp. Motor Input	Sensible To Total Ratio (S/T)			Total Cool Cap.	Comp. Motor Input	Sensible To Total Ratio (S/T)			Total Cool Cap.	Comp. Motor Input	Sensible To Total Ratio (S/T)			
				Dry Bulb					Dry Bulb					Dry Bulb					Dry Bulb			
cfm	kBtuh	kW	75°F	80°F	85°F	kBtuh	kW	75°F	80°F	85°F	kBtuh	kW	75°F	80°F	85°F	kBtuh	kW	75°F	80°F	85°F		
63°F	1600	58.1	3.63	0.74	0.88	0.99	53.4	4.08	0.74	0.89	1.00	48.4	4.61	0.75	0.91	1.00	43.0	5.23	0.76	0.94	1.00	
	2000	61.8	3.65	0.80	0.95	1.00	56.8	4.10	0.81	0.97	1.00	51.6	4.64	0.82	0.99	1.00	46.1	5.27	0.84	1.00	1.00	
	2400	64.8	3.66	0.85	1.00	1.00	59.9	4.12	0.86	1.00	1.00	54.9	4.67	0.89	1.00	1.00	49.7	5.32	0.91	1.00	1.00	
67°F	1600	62.7	3.65	0.57	0.72	0.85	57.8	4.11	0.56	0.72	0.86	52.6	4.65	0.55	0.73	0.88	47.0	5.28	0.54	0.74	0.91	
	2000	66.6	3.67	0.61	0.78	0.92	61.4	4.14	0.61	0.79	0.94	55.8	4.68	0.60	0.81	0.96	49.6	5.31	0.60	0.83	0.99	
	2400	69.3	3.69	0.65	0.83	0.98	63.7	4.16	0.65	0.85	1.00	58.0	4.71	0.66	0.87	1.00	51.7	5.35	0.66	0.90	1.00	
71°F	1600	67.2	3.67	0.42	0.56	0.70	62.1	4.14	0.40	0.55	0.70	56.8	4.69	0.38	0.55	0.71	50.8	5.33	0.35	0.54	0.72	
	2000	71.2	3.70	0.43	0.60	0.76	65.9	4.17	0.42	0.60	0.77	60.0	4.72	0.40	0.60	0.79	53.8	5.37	0.39	0.60	0.81	
	2400	74.3	3.72	0.45	0.64	0.82	68.4	4.19	0.44	0.65	0.83	62.4	4.75	0.43	0.65	0.85	56.0	5.40	0.42	0.66	0.88	

RATINGS

NOTE – For Temperatures and Capacities not shown in tables, see bulletin – Cooling Unit Rating Table Correction Factor Data in Miscellaneous Engineering Data section.

6 TON - ZGD074S5T (PART LOAD)

Entering Wet Bulb Temperature	Total Air Volume	Outdoor Air Temperature Entering Outdoor Coil																			
		65°F					75°F					85°F					95°F				
		Total Cool Cap.	Comp. Motor Input	Sensible To Total Ratio (S/T)			Total Cool Cap.	Comp. Motor Input	Sensible To Total Ratio (S/T)			Total Cool Cap.	Comp. Motor Input	Sensible To Total Ratio (S/T)			Total Cool Cap.	Comp. Motor Input	Sensible To Total Ratio (S/T)		
				Dry Bulb					Dry Bulb					Dry Bulb					Dry Bulb		
cfm	kBtuh	kW	75°F	80°F	85°F	kBtuh	kW	75°F	80°F	85°F	kBtuh	kW	75°F	80°F	85°F	kBtuh	kW	75°F	80°F	85°F	
63°F	1200	50.3	2.24	0.67	0.79	0.92	47.3	2.56	0.67	0.8	0.94	44.2	2.91	0.67	0.82	0.96	40.7	3.32	0.68	0.83	0.99
	1600	55	2.24	0.73	0.88	1	51.6	2.55	0.74	0.9	1	48.1	2.91	0.74	0.92	1	44.3	3.32	0.76	0.95	1
	2000	58.1	2.23	0.79	0.97	1	54.6	2.55	0.8	0.99	1	51	2.91	0.81	1	1	47.5	3.32	0.84	1	1
67°F	1200	54.1	2.24	0.53	0.65	0.76	51	2.56	0.53	0.65	0.77	47.7	2.91	0.52	0.65	0.78	44.1	3.32	0.52	0.65	0.79
	1600	59	2.23	0.57	0.7	0.84	55.6	2.55	0.57	0.71	0.86	51.9	2.91	0.56	0.72	0.88	48	3.32	0.57	0.73	0.91
	2000	62.4	2.22	0.6	0.76	0.93	58.7	2.54	0.61	0.77	0.95	54.8	2.91	0.61	0.79	0.97	50.7	3.32	0.61	0.81	1
71°F	1200	57.8	2.23	0.41	0.52	0.62	54.6	2.55	0.4	0.52	0.62	51.2	2.91	0.39	0.51	0.63	47.5	3.32	0.37	0.51	0.63
	1600	63.1	2.22	0.43	0.55	0.68	59.5	2.54	0.42	0.56	0.69	55.7	2.91	0.41	0.56	0.7	51.8	3.32	0.4	0.56	0.71
	2000	66.6	2.21	0.44	0.59	0.74	62.9	2.54	0.44	0.6	0.75	58.8	2.9	0.43	0.6	0.76	54.5	3.31	0.43	0.6	0.78

6 TON - ZGD074S5T (FULL LOAD)

Entering Wet Bulb Temperature	Total Air Volume	Outdoor Air Temperature Entering Outdoor Coil																			
		85°F					95°F					105°F					115°F				
		Total Cool Cap.	Comp. Motor Input	Sensible To Total Ratio (S/T)			Total Cool Cap.	Comp. Motor Input	Sensible To Total Ratio (S/T)			Total Cool Cap.	Comp. Motor Input	Sensible To Total Ratio (S/T)			Total Cool Cap.	Comp. Motor Input	Sensible To Total Ratio (S/T)		
				Dry Bulb					Dry Bulb					Dry Bulb					Dry Bulb		
cfm	kBtuh	kW	75°F	80°F	85°F	kBtuh	kW	75°F	80°F	85°F	kBtuh	kW	75°F	80°F	85°F	kBtuh	kW	75°F	80°F	85°F	
63°F	1920	66.9	4.13	0.71	0.87	1.00	62.5	4.66	0.72	0.89	1.00	57.7	5.27	0.74	0.92	1.00	52.7	5.97	0.76	0.96	1.00
	2400	70.5	4.16	0.77	0.96	1.00	65.7	4.70	0.79	0.98	1.00	60.9	5.30	0.81	1.00	1.00	56.1	6.01	0.84	1.00	1.00
	2880	73.4	4.19	0.83	1.00	1.00	69.1	4.73	0.85	1.00	1.00	64.5	5.35	0.89	1.00	1.00	59.4	6.05	0.92	1.00	1.00
67°F	1920	71.5	4.17	0.55	0.69	0.83	66.9	4.71	0.56	0.70	0.85	61.8	5.32	0.56	0.72	0.88	56.7	6.01	0.56	0.73	0.92
	2400	75.2	4.21	0.59	0.75	0.92	70.3	4.75	0.59	0.77	0.95	64.9	5.35	0.60	0.79	0.98	59.5	6.05	0.61	0.82	1.00
	2880	78.0	4.24	0.63	0.81	0.99	72.6	4.78	0.63	0.83	1.00	67.0	5.38	0.64	0.86	1.00	61.3	6.07	0.66	0.90	1.00
71°F	1920	75.8	4.22	0.41	0.54	0.67	71.2	4.76	0.41	0.55	0.68	66.0	5.36	0.40	0.55	0.69	60.5	6.06	0.38	0.55	0.71
	2400	79.8	4.26	0.43	0.58	0.73	74.6	4.80	0.42	0.59	0.74	69.4	5.41	0.41	0.60	0.76	63.5	6.10	0.41	0.61	0.79
	2880	82.8	4.30	0.44	0.62	0.79	77.4	4.84	0.44	0.63	0.81	71.6	5.44	0.44	0.64	0.84	65.7	6.14	0.44	0.66	0.88

BLOWER DATA

ZGD036S5E DIRECT DRIVE (SINGLE PHASE)

BLOWER TABLE INCLUDES RESISTANCE FOR BASE UNIT ONLY WITH DRY INDOOR COIL AND AIR FILTERS IN PLACE.

FOR ALL UNITS ADD:

1 - Any factory installed options air resistance (heat section, economizer, etc.).

2 - Any field installed accessories air resistance (duct resistance, diffuser, etc.).

See page 29 for wet coil and options/accessory air resistance data.

DOWNFLOW

External Static Press. in. w.g.	Blower Only			Low Speed						High Speed						Free Cooling		
	Low and High Speed: G (Pin 1)			1st Stage Heating: W1 (Pin 2) Cooling: Y1 (Pin 2 and 5)			2nd Stage Heating: W2 (Pin 2 and 4)			1st Stage Heating: W1 (Pin 3) 2nd Stage Heating: W2 (Pin 3 and 4)			Cooling: Y1 (Pin 3 and 5)			Low and High Speed: Y1 (Pin 1 and 5)		
	CFM	Watts	RPM	CFM	Watts	RPM	CFM	Watts	RPM	CFM	Watts	RPM	CFM	Watts	RPM	CFM	Watts	RPM
0	752	47	407	1127	142	623	1474	294	803	1664	404	887	1474	294	803	1474	294	803
0.1	694	53	482	1089	150	668	1445	304	835	1636	419	922	1445	304	835	1445	304	835
0.2	627	60	535	1049	158	713	1414	314	871	1613	430	949	1414	314	871	1414	314	871
0.3	560	66	602	1007	167	760	1389	323	898	1579	445	987	1389	323	898	1389	323	898
0.4	502	70	694	965	175	805	1350	335	940	1556	454	1011	1350	335	940	1350	335	940
0.5	---	---	---	923	183	849	1314	347	978	1522	466	1045	1314	347	978	1314	347	978
0.6	---	---	---	881	191	891	1287	356	1008	1488	475	1076	1287	356	1008	1287	356	1008
0.7	---	---	---	826	201	945	1251	367	1045	1442	485	1114	1251	367	1045	1251	367	1045
0.8	---	---	---	785	208	983	1219	377	1078	1408	490	1140	1219	377	1078	1219	377	1078
0.9	---	---	---	646	190	836	1181	389	1117	1363	494	1170	1181	389	1117	1181	389	1117
1.0	---	---	---	618	195	863	1147	400	1152	1317	494	1196	1147	400	1152	1147	400	1152

HORIZONTAL

External Static Press. in. w.g.	Blower Only			Low Speed						High Speed						Free Cooling		
	Low and High Speed: G (Pin 1)			1st Stage Heating: W1 (Pin 2) Cooling: Y1 (Pin 2 and 5)			2nd Stage Heating: W2 (Pin 2 and 4)			1st Stage Heating: W1 (Pin 3) 2nd Stage Heating: W2 (Pin 3 and 4)			Cooling: Y1 (Pin 3 and 5)			Low and High Speed: Y1 (Pin 1 and 5)		
	CFM	Watts	RPM	CFM	Watts	RPM	CFM	Watts	RPM	CFM	Watts	RPM	CFM	Watts	RPM	CFM	Watts	RPM
0	737	50	416	1255	179	671	1539	311	794	1666	386	850	1588	340	818	1539	311	794
0.1	676	56	485	1221	188	701	1509	321	827	1637	402	886	1560	350	849	1509	321	827
0.2	606	62	560	1179	199	749	1475	334	866	1614	414	914	1527	363	885	1475	334	866
0.3	536	68	628	1138	209	795	1446	344	896	1580	430	954	1493	376	921	1446	344	896
0.4	475	73	683	1096	219	840	1411	357	935	1545	445	991	1460	388	958	1411	357	935
0.5	---	---	---	1053	229	883	1375	369	972	1510	457	1027	1426	401	993	1375	369	972
0.6	---	---	---	1012	239	925	1341	381	1010	1475	468	1060	1393	413	1029	1341	381	1010
0.7	---	---	---	960	250	975	1305	393	1047	1441	478	1090	1359	426	1064	1305	393	1047
0.8	---	---	---	918	259	1012	1263	408	1090	1394	487	1128	1326	438	1100	1263	408	1090
0.9	---	---	---	873	268	1060	1216	423	1138	1360	492	1153	1281	454	1146	1216	423	1138
1.0	---	---	---	826	277	1094	1180	435	1173	1314	496	1183	1247	466	1181	1180	435	1173

BLOWER DATA

ZGD048S5E DIRECT DRIVE (SINGLE PHASE)

BLOWER TABLE INCLUDES RESISTANCE FOR BASE UNIT ONLY WITH DRY INDOOR COIL AND AIR FILTERS IN PLACE.

FOR ALL UNITS ADD:

1 - Any factory installed options air resistance (heat section, economizer, etc.).

2 - Any field installed accessories air resistance (duct resistance, diffuser, etc.).

See page 29 for wet coil and options/accessory air resistance data.

DOWNFLOW

External Static Press. in. w.g.	Blower Only			Low Speed						High Speed						Free Cooling		
	Low and High Speed: G (Pin 1)			1st Stage Heating: W1 (Pin 2) Cooling: Y1 (Pin 2 and 5)			2nd Stage Heating: W2 (Pin 2 and 4)			1st Stage Heating: W1 (Pin 3) 2nd Stage Heating: W2 (Pin 3 and 4)			Cooling: Y1 (Pin 3 and 5)			Low and High Speed: Y1 (Pin 1 and 5)		
	CFM	Watts	RPM	CFM	Watts	RPM	CFM	Watts	RPM	CFM	Watts	RPM	CFM	Watts	RPM	CFM	Watts	RPM
0	933	82	507	1724	438	911	1514	294	779	1832	529	970	2051	754	1084	1884	579	998
0.1	884	90	568	1699	450	940	1477	306	820	1810	540	994	2017	750	1100	1864	591	1021
0.2	829	99	634	1672	462	970	1441	318	859	1784	553	1022	1976	746	1119	1838	606	1050
0.3	787	105	681	1636	478	1010	1406	329	897	1748	570	1060	1935	743	1138	1806	622	1084
0.4	732	113	739	1609	491	1040	1359	345	948	1722	583	1089	1894	739	1156	1779	636	1113
0.5	676	120	794	1582	503	1070	1324	356	985	1696	597	1117	1853	736	1174	1755	647	1138
0.6	621	127	844	1555	515	1099	1289	367	1022	1670	610	1146	1812	732	1192	1723	660	1169
0.7	552	134	901	1528	527	1128	1254	378	1058	1644	623	1174	1757	728	1214	1694	670	1195
0.8	510	138	932	1492	542	1167	1219	389	1093	1617	636	1203	1716	726	1231	1666	679	1219
0.9	---	---	---	1465	554	1195	1190	399	1122	1591	649	1231	1675	723	1247	1634	686	1245
1.0	---	---	---	1442	564	1219	1158	409	1155	1560	665	1265	1627	720	1265	1592	691	1273

HORIZONTAL

External Static Press. in. w.g.	Blower Only			Low Speed						High Speed						Free Cooling		
	Low and High Speed: G (Pin 1)			1st Stage Heating: W1 (Pin 2) Cooling: Y1 (Pin 2 and 5)			2nd Stage Heating: W2 (Pin 2 and 4)			1st Stage Heating: W1 (Pin 3) 2nd Stage Heating: W2 (Pin 3 and 4)			Cooling: Y1 (Pin 3 and 5)			Low and High Speed: Y1 (Pin 1 and 5)		
	CFM	Watts	RPM	CFM	Watts	RPM	CFM	Watts	RPM	CFM	Watts	RPM	CFM	Watts	RPM	CFM	Watts	RPM
0	935	82	508	1746	434	900	1524	292	794	1858	518	1043	2089	756	1068	1914	569	1030
0.1	886	90	572	1724	445	927	1497	302	825	1834	532	988	2066	754	1081	1893	582	1007
0.2	845	97	624	1697	458	960	1465	314	863	1807	546	939	2021	750	1102	1865	600	996
0.3	803	104	673	1669	472	993	1433	326	901	1781	560	908	1976	746	1123	1841	614	989
0.4	748	112	733	1642	485	1025	1402	337	938	1754	574	897	1946	744	1144	1812	629	997
0.5	692	119	789	1606	502	1068	1370	349	974	1728	588	904	1887	739	1165	1784	643	1014
0.6	637	126	839	1579	515	1099	1338	360	1011	1701	602	930	1857	737	1194	1755	655	1041
0.7	554	135	905	1552	528	1130	1295	376	1059	1666	620	995	1797	733	1215	1722	668	1089
0.8	505	139	937	1515	545	1171	1263	387	1095	1640	633	1065	1752	730	1236	1694	678	1138
0.9	---	---	---	1488	558	1202	1232	398	1130	1613	646	1153	1692	726	1264	1652	684	1204
1.0	---	---	---	1466	568	1227	1200	410	1165	1582	661	1281	1632	723	1288	1619	689	1283

BLOWER DATA

ZGD060S5E DIRECT DRIVE (SINGLE PHASE)

BLOWER TABLE INCLUDES RESISTANCE FOR BASE UNIT ONLY WITH DRY INDOOR COIL AND AIR FILTERS IN PLACE.

FOR ALL UNITS ADD:

1 - Any factory installed options air resistance (heat section, economizer, etc.).

2 - Any field installed accessories air resistance (duct resistance, diffuser, etc.).

See page 29 for wet coil and options/accessory air resistance data.

DOWNFLOW

External Static Press. in. w.g.	Blower Only			Low Speed									High Speed									Free Cooling				
	Low and High Speed: G (Pin 1)			1st Stage Heating: W1 (Pin 2)			2nd Stage Heating: W2 (Pin 2 and 4)			Cooling: Y1 (Pin 2 and 5)			1st Stage Heating: W1 (Pin 3)			2nd Stage Heating: W2 (Pin 3 and 4)			Cooling: Y1 (Pin 3 and 5)			Low and High Speed: Y1 (Pin 1 and 5)				
	CFM	Watts	RPM	CFM	Watts	RPM	CFM	Watts	RPM	CFM	Watts	RPM	CFM	Watts	RPM	CFM	Watts	RPM	CFM	Watts	RPM	CFM	Watts	RPM	CFM	Watts
0	1076	108	495	1708	387	602	1938	553	860	1846	469	781	1708	387	602	2263	916	1027	2108	746	964	2108	746	964		
0.1	1017	118	551	1677	398	680	1910	566	884	1818	481	816	1677	398	680	2230	928	1048	2082	760	987	2082	760	987		
0.2	966	126	598	1642	411	758	1879	581	912	1785	495	855	1642	411	758	2190	942	1073	2054	776	1012	2054	776	1012		
0.3	915	135	644	1602	425	831	1837	601	949	1742	513	900	1602	425	831	2150	952	1096	2018	797	1045	2018	797	1045		
0.4	847	145	703	1573	436	885	1815	612	970	1719	523	926	1573	436	885	2110	960	1118	1990	812	1069	1990	812	1069		
0.5	796	153	745	1532	451	939	1775	630	1004	1676	541	967	1532	451	939	2070	966	1139	1962	828	1093	1962	828	1093		
0.6	745	160	786	1497	463	979	1743	644	1031	1643	555	998	1497	463	979	2030	969	1158	1934	843	1117	1934	843	1117		
0.7	694	167	825	1456	478	1014	1712	658	1058	1609	569	1027	1456	478	1014	1990	969	1176	1906	858	1140	1906	858	1140		
0.8	643	174	863	1415	492	1038	1670	677	1093	1565	587	1061	1415	492	1038	1950	968	1192	1870	877	1171	1870	877	1171		
0.9	592	180	900	1381	505	1047	1639	691	1120	1533	601	1085	1381	505	1047	1897	961	1212	1842	892	1194	1842	892	1194		
1.0	558	184	923	1345	517	1042	1612	703	1141	1503	612	1102	1345	517	1042	1857	953	1225	1819	904	1213	1819	904	1213		

HORIZONTAL

External Static Press. in. w.g.	Blower Only			Low Speed									High Speed									Free Cooling				
	Low and High Speed: G (Pin 1)			1st Stage Heating: W1 (Pin 2)			2nd Stage Heating: W2 (Pin 2 and 4)			Cooling: Y1 (Pin 2 and 5)			1st Stage Heating: W1 (Pin 3)			2nd Stage Heating: W2 (Pin 3 and 4)			Cooling: Y1 (Pin 3 and 5)			Low and High Speed: Y1 (Pin 1 and 5)				
	CFM	Watts	RPM	CFM	Watts	RPM	CFM	Watts	RPM	CFM	Watts	RPM	CFM	Watts	RPM	CFM	Watts	RPM	CFM	Watts	RPM	CFM	Watts	RPM	CFM	Watts
0	1061	111	507	1693	386	764	1926	555	862	1825	472	820	1693	386	764	2244	870	992	2131	739	945	2131	739	945		
0.1	1015	119	551	1662	398	792	1897	568	887	1796	484	846	1662	398	792	2224	885	1012	2097	753	970	2097	753	970		
0.2	965	127	597	1627	410	822	1866	581	913	1764	498	874	1627	410	822	2189	909	1043	2068	765	992	2068	765	992		
0.3	915	135	642	1581	427	863	1827	598	947	1722	516	912	1581	427	863	2166	922	1062	2038	778	1015	2038	778	1015		
0.4	865	143	685	1552	437	888	1802	609	968	1699	525	931	1552	437	888	2131	940	1089	2000	797	1046	2000	797	1046		
0.5	798	153	741	1512	452	923	1763	627	1001	1658	542	967	1512	452	923	2097	953	1114	1970	812	1070	1970	812	1070		
0.6	765	157	767	1478	465	953	1733	641	1028	1626	556	995	1478	465	953	2062	963	1136	1941	827	1095	1941	827	1095		
0.7	698	167	819	1443	477	983	1701	655	1055	1593	569	1023	1443	477	983	2027	968	1156	1912	844	1120	1912	844	1120		
0.8	648	173	855	1397	494	1023	1663	673	1088	1551	587	1060	1397	494	1023	1981	970	1178	1882	860	1146	1882	860	1146		
0.9	598	180	891	1369	504	1047	1632	687	1115	1520	600	1086	1369	504	1047	1923	963	1199	1853	878	1172	1853	878	1172		
1.0	539	187	930	1334	516	1077	1606	700	1138	1492	611	1110	1334	516	1077	1883	951	1210	1829	893	1195	1829	893	1195		

BLOWER DATA

ZGD036S5E DIRECT DRIVE (THREE PHASE)

BLOWER TABLE INCLUDES RESISTANCE FOR BASE UNIT ONLY WITH DRY INDOOR COIL AND AIR FILTERS IN PLACE.

FOR ALL UNITS ADD:

1 - Any factory installed options air resistance (heat section, economizer, etc.).

2 - Any field installed accessories air resistance (duct resistance, diffuser, etc.).

See page 29 for wet coil and options/accessory air resistance data.

DOWNFLOW

External Static Press. in. w.g.	Tap 1: Pin 1			Tap 2: Pin 2			Tap 3: Pin 3			Tap 4: Pin 4			Tap 5: Pin 5		
	CFM	Watts	RPM	CFM	Watts	RPM	CFM	Watts	RPM	CFM	Watts	RPM	CFM	Watts	RPM
0	1086	130	601	1127	142	623	1182	157	653	1474	294	803	1664	404	887
0.1	1046	138	649	1089	150	668	1146	165	694	1445	304	835	1636	419	922
0.2	1006	146	695	1049	158	713	1107	174	738	1414	314	871	1613	430	949
0.3	962	154	745	1007	167	760	1068	183	781	1389	323	898	1579	445	987
0.4	918	162	792	965	175	805	1029	192	823	1350	335	940	1556	454	1011
0.5	873	170	838	923	183	849	990	200	864	1314	347	978	1522	466	1045
0.6	829	178	882	881	191	891	951	208	905	1287	356	1008	1488	475	1076
0.7	771	187	935	826	201	945	899	219	957	1251	367	1045	1442	485	1114
0.8	729	194	973	785	208	983	860	227	995	1219	377	1078	1408	490	1140
0.9	525	154	679	646	190	836	808	237	1045	1181	389	1117	1363	494	1170
1.0	502	159	701	618	195	863	772	244	1078	1147	400	1152	1317	494	1196

HORIZONTAL

External Static Press. in. w.g.	Tap 1: Pin 1			Tap 2: Pin 2			Tap 3: Pin 3			Tap 4: Pin 4			Tap 5: Pin 5		
	CFM	Watts	RPM	CFM	Watts	RPM	CFM	Watts	RPM	CFM	Watts	RPM	CFM	Watts	RPM
0	1218	166	651	1255	179	671	1305	195	698	1539	311	794	1666	386	850
0.1	1183	175	684	1221	188	701	1272	205	723	1509	321	827	1637	402	886
0.2	1140	186	733	1179	199	749	1232	216	769	1475	334	866	1614	414	914
0.3	1097	196	781	1138	209	795	1192	227	814	1446	344	896	1580	430	954
0.4	1054	206	828	1096	219	840	1152	237	857	1411	357	935	1545	445	991
0.5	1010	215	872	1053	229	883	1111	247	898	1375	369	972	1510	457	1027
0.6	967	225	915	1012	239	925	1071	257	938	1341	381	1010	1475	468	1060
0.7	916	236	964	960	250	975	1018	270	989	1305	393	1047	1441	478	1090
0.8	873	244	1003	918	259	1012	978	279	1025	1263	408	1090	1394	487	1128
0.9	825	253	1052	873	268	1060	938	288	1070	1216	423	1138	1360	492	1153
1.0	777	262	1087	826	277	1094	891	298	1103	1180	435	1173	1314	496	1183

BLOWER DATA**ZGD048S5E DIRECT DRIVE (THREE PHASE)****BLOWER TABLE INCLUDES RESISTANCE FOR BASE UNIT ONLY WITH DRY INDOOR COIL AND AIR FILTERS IN PLACE.**

FOR ALL UNITS ADD:

1 - Any factory installed options air resistance (heat section, economizer, etc.).

2 - Any field installed accessories air resistance (duct resistance, diffuser, etc.).

See page 29 for wet coil and options/accessory air resistance data.

DOWNFLOW

External Static Press. in. w.g.	Tap 1: Pin 1			Tap 2: Pin 2			Tap 3: Pin 3			Tap 4: Pin 4			Tap 5: Pin 5		
	CFM	Watts	RPM	CFM	Watts	RPM	CFM	Watts	RPM	CFM	Watts	RPM	CFM	Watts	RPM
0	1455	258	741	1514	294	779	1724	438	911	1884	579	998	2051	754	1084
0.1	1417	270	786	1477	306	820	1699	450	940	1864	591	1021	2017	750	1100
0.2	1379	282	828	1441	318	859	1672	462	970	1838	606	1050	1976	746	1119
0.3	1342	293	869	1406	329	897	1636	478	1010	1806	622	1084	1935	743	1138
0.4	1292	309	923	1359	345	948	1609	491	1040	1779	636	1113	1894	739	1156
0.5	1254	320	963	1324	356	985	1582	503	1070	1755	647	1138	1853	736	1174
0.6	1217	331	1001	1289	367	1022	1555	515	1099	1723	660	1169	1812	732	1192
0.7	1180	342	1040	1254	378	1058	1528	527	1128	1694	670	1195	1757	728	1214
0.8	1142	352	1077	1219	389	1093	1492	542	1167	1666	679	1219	1716	726	1231
0.9	1114	361	1104	1190	399	1122	1465	554	1195	1634	686	1245	1675	723	1247
1.0	1079	371	1139	1158	409	1155	1442	564	1219	1592	691	1273	1627	720	1265

HORIZONTAL

External Static Press. in. w.g.	Tap 1: Pin 1			Tap 2: Pin 2			Tap 3: Pin 3			Tap 4: Pin 4			Tap 5: Pin 5		
	CFM	Watts	RPM	CFM	Watts	RPM	CFM	Watts	RPM	CFM	Watts	RPM	CFM	Watts	RPM
0	1453	259	761	1524	292	794	1746	434	900	1914	569	1030	2089	756	1068
0.1	1425	269	795	1497	302	825	1724	445	927	1893	582	1007	2066	754	1081
0.2	1391	281	835	1465	314	863	1697	458	960	1865	600	996	2021	750	1102
0.3	1358	292	874	1433	326	901	1669	472	993	1841	614	989	1976	746	1123
0.4	1325	303	913	1402	337	938	1642	485	1025	1812	629	997	1946	744	1144
0.5	1292	314	951	1370	349	974	1606	502	1068	1784	643	1014	1887	739	1165
0.6	1258	325	989	1338	360	1011	1579	515	1099	1755	655	1041	1857	737	1194
0.7	1214	340	1038	1295	376	1059	1552	528	1130	1722	668	1089	1797	733	1215
0.8	1181	350	1075	1263	387	1095	1515	545	1171	1694	678	1138	1752	730	1236
0.9	1148	361	1110	1232	398	1130	1488	558	1202	1652	684	1204	1692	726	1264
1.0	1112	372	1148	1200	410	1165	1466	568	1227	1619	689	1283	1632	723	1288

BLOWER DATA

ZGD060S5E DIRECT DRIVE (THREE PHASE)

BLOWER TABLE INCLUDES RESISTANCE FOR BASE UNIT ONLY WITH DRY INDOOR COIL AND AIR FILTERS IN PLACE.

FOR ALL UNITS ADD:

1 - Any factory installed options air resistance (heat section, economizer, etc.).

2 - Any field installed accessories air resistance (duct resistance, diffuser, etc.).

See page 29 for wet coil and options/accessory air resistance data.

DOWNFLOW

External Static Press. in. w.g.	Tap 1: Pin 1			Tap 2: Pin 2			Tap 3: Pin 3			Tap 4: Pin 4			Tap 5: Pin 5		
	CFM	Watts	RPM	CFM	Watts	RPM	CFM	Watts	RPM	CFM	Watts	RPM	CFM	Watts	RPM
0	1795	438	714	1846	469	781	1938	553	860	2108	746	964	2263	916	1027
0.1	1765	450	765	1818	481	816	1910	566	884	2082	760	987	2230	928	1048
0.2	1732	463	818	1785	495	855	1879	581	912	2054	776	1012	2190	942	1073
0.3	1689	480	874	1742	513	900	1837	601	949	2018	797	1045	2150	952	1096
0.4	1664	490	911	1719	523	926	1815	612	970	1990	812	1069	2110	960	1118
0.5	1622	507	957	1676	541	967	1775	630	1004	1962	828	1093	2070	966	1139
0.6	1588	521	991	1643	555	998	1743	644	1031	1934	843	1117	2030	969	1158
0.7	1551	535	1022	1609	569	1027	1712	658	1058	1906	858	1140	1990	969	1176
0.8	1509	552	1052	1565	587	1061	1670	677	1093	1870	877	1171	1950	968	1192
0.9	1476	565	1071	1533	601	1085	1639	691	1120	1842	892	1194	1897	961	1212
1.0	1444	577	1080	1503	612	1102	1612	703	1141	1819	904	1213	1857	953	1225

HORIZONTAL

External Static Press. in. w.g.	Tap 1: Pin 1			Tap 2: Pin 2			Tap 3: Pin 3			Tap 4: Pin 4			Tap 5: Pin 5		
	CFM	Watts	RPM	CFM	Watts	RPM	CFM	Watts	RPM	CFM	Watts	RPM	CFM	Watts	RPM
0	1776	440	799	1825	472	820	1926	555	862	2131	739	945	2244	870	992
0.1	1746	452	826	1796	484	846	1897	568	887	2097	753	970	2224	885	1012
0.2	1713	465	855	1764	498	874	1866	581	913	2068	765	992	2189	909	1043
0.3	1669	482	893	1722	516	912	1827	598	947	2038	778	1015	2166	922	1062
0.4	1644	492	915	1699	525	931	1802	609	968	2000	797	1046	2131	940	1089
0.5	1603	509	951	1658	542	967	1763	627	1001	1970	812	1070	2097	953	1114
0.6	1570	522	979	1626	556	995	1733	641	1028	1941	827	1095	2062	963	1136
0.7	1537	535	1008	1593	569	1023	1701	655	1055	1912	844	1120	2027	968	1156
0.8	1494	552	1046	1551	587	1060	1663	673	1088	1882	860	1146	1981	970	1178
0.9	1463	564	1072	1520	600	1086	1632	687	1115	1853	878	1172	1923	963	1199
1.0	1433	576	1098	1492	611	1110	1606	700	1138	1829	893	1195	1883	951	1210

BLOWER DATA

ZGD036S5B BELT DRIVE (THREE PHASE)

BLOWER TABLE INCLUDES RESISTANCE FOR BASE UNIT ONLY WITH DRY INDOOR COIL AND AIR FILTERS IN PLACE.

FOR ALL UNITS ADD:

1 - Any factory installed options air resistance (heat section, economizer, wet coil, etc.).

2 - Any field installed accessories air resistance (duct resistance, diffuser, etc.).

See page 29 for blower motors and drives and wet coil and options/accessory air resistance data.

DOWNFLOW

Air Volume cfm	External Static - in. w.g.															
	0.10		0.20		0.30		0.40		0.50		0.60		0.70		0.80	
	RPM	BHP	RPM	BHP	RPM	BHP	RPM	BHP	RPM	BHP	RPM	BHP	RPM	BHP	RPM	BHP
900	573	0.16	639	0.18	707	0.19	776	0.21	844	0.23	908	0.25	967	0.27	1022	0.30
1000	600	0.18	665	0.20	733	0.22	802	0.23	868	0.25	930	0.28	986	0.31	1038	0.33
1100	628	0.21	695	0.22	762	0.24	829	0.26	893	0.29	953	0.31	1007	0.35	1057	0.38
1200	660	0.23	727	0.25	794	0.27	859	0.29	921	0.32	977	0.36	1029	0.39	1077	0.42
1300	695	0.26	761	0.28	827	0.31	890	0.33	949	0.37	1003	0.40	1053	0.44	1099	0.47
1400	734	0.30	799	0.32	862	0.35	923	0.38	978	0.41	1030	0.45	1078	0.49	1122	0.53
1500	775	0.34	837	0.37	898	0.40	955	0.43	1009	0.46	1058	0.50	1104	0.54	1147	0.58

Air Volume cfm	External Static - in. w.g.															
	0.90		1.00		1.10		1.20		1.30		1.40		1.50		1.60	
	RPM	BHP	RPM	BHP	RPM	BHP	RPM	BHP	RPM	BHP	RPM	BHP	RPM	BHP	RPM	BHP
900	1072	0.32	1120	0.35	1166	0.38	1210	0.41	1252	0.44	1292	0.47	1331	0.5	1370	0.54
1000	1087	0.36	1134	0.39	1179	0.42	1222	0.45	1263	0.48	1303	0.51	1341	0.55	1379	0.58
1100	1104	0.40	1150	0.43	1194	0.46	1236	0.49	1277	0.53	1315	0.56	1353	0.60	1390	0.64
1200	1123	0.45	1167	0.48	1210	0.51	1251	0.55	1291	0.58	1330	0.62	1367	0.66	1403	0.70
1300	1143	0.50	1186	0.54	1228	0.57	1268	0.60	1308	0.64	1346	0.68	1382	0.72	1418	0.76
1400	1165	0.56	1206	0.59	1247	0.63	1287	0.67	1326	0.70	1363	0.75	1399	0.79	1435	0.83
1500	1188	0.62	1229	0.66	1269	0.69	1308	0.73	1346	0.77	1382	0.82	1418	0.86	1453	0.90

HORIZONTAL

Air Volume cfm	External Static - in. w.g.															
	0.10		0.20		0.30		0.40		0.50		0.60		0.70		0.80	
	RPM	BHP	RPM	BHP	RPM	BHP	RPM	BHP	RPM	BHP	RPM	BHP	RPM	BHP	RPM	BHP
900	573	0.14	642	0.16	712	0.18	780	0.21	846	0.23	909	0.26	967	0.28	1022	0.31
1000	599	0.16	668	0.18	737	0.21	804	0.23	868	0.26	928	0.29	984	0.32	1037	0.35
1100	626	0.18	695	0.21	764	0.24	830	0.26	892	0.29	950	0.32	1003	0.36	1053	0.39
1200	656	0.21	726	0.24	794	0.27	858	0.30	918	0.33	973	0.37	1024	0.40	1072	0.43
1300	691	0.25	761	0.28	827	0.31	889	0.34	945	0.38	998	0.41	1047	0.45	1093	0.48
1400	731	0.29	798	0.32	862	0.35	920	0.39	974	0.42	1024	0.46	1071	0.49	1115	0.53
1500	773	0.34	838	0.37	898	0.40	952	0.44	1004	0.47	1051	0.51	1096	0.55	1139	0.58

Air Volume cfm	External Static - in. w.g.															
	0.90		1.00		1.10		1.20		1.30		1.40		1.50		1.60	
	RPM	BHP	RPM	BHP	RPM	BHP	RPM	BHP	RPM	BHP	RPM	BHP	RPM	BHP	RPM	BHP
900	1074	0.33	1123	0.36	1171	0.39	1216	0.41	1260	0.44	1301	0.47	1340	0.49	1378	0.52
1000	1087	0.37	1135	0.40	1181	0.42	1226	0.45	1269	0.48	1310	0.51	1350	0.54	1388	0.57
1100	1101	0.41	1148	0.44	1193	0.47	1237	0.49	1279	0.52	1321	0.55	1360	0.59	1398	0.62
1200	1118	0.46	1163	0.48	1208	0.51	1251	0.54	1293	0.58	1334	0.61	1375	0.64	1414	0.68
1300	1137	0.51	1181	0.53	1224	0.57	1267	0.60	1309	0.63	1350	0.67	1391	0.71	1432	0.75
1400	1158	0.56	1200	0.59	1242	0.62	1284	0.66	1326	0.70	1367	0.74	1407	0.79	1448	0.83
1500	1180	0.61	1222	0.65	1263	0.69	1304	0.73	1345	0.77	1386	0.82	1427	0.87	1467	0.92

BLOWER DATA

ZGD048S5B BELT DRIVE (THREE PHASE)

BLOWER TABLE INCLUDES RESISTANCE FOR BASE UNIT ONLY WITH DRY INDOOR COIL AND AIR FILTERS IN PLACE.

FOR ALL UNITS ADD:

1 - Any factory installed options air resistance (heat section, economizer, wet coil, etc.).

2 - Any field installed accessories air resistance (duct resistance, diffuser, etc.).

See page 29 for blower motors and drives and wet coil and options/accessory air resistance data.

DOWNFLOW

Air Volume cfm	External Static - in. w.g.															
	0.10		0.20		0.30		0.40		0.50		0.60		0.70		0.80	
	RPM	BHP	RPM	BHP	RPM	BHP	RPM	BHP	RPM	BHP	RPM	BHP	RPM	BHP	RPM	BHP
1200	660	0.23	727	0.25	794	0.27	859	0.29	921	0.32	977	0.36	1029	0.39	1077	0.42
1300	695	0.26	761	0.28	827	0.31	890	0.33	949	0.37	1003	0.40	1053	0.44	1099	0.47
1400	734	0.30	799	0.32	862	0.35	923	0.38	978	0.41	1030	0.45	1078	0.49	1122	0.53
1500	775	0.34	837	0.37	898	0.40	955	0.43	1009	0.46	1058	0.50	1104	0.54	1147	0.58
1600	817	0.39	877	0.42	935	0.45	989	0.48	1040	0.52	1087	0.56	1131	0.60	1173	0.65
1700	859	0.44	917	0.47	972	0.50	1023	0.54	1071	0.58	1117	0.62	1159	0.67	1199	0.71
1800	902	0.49	957	0.53	1008	0.56	1057	0.60	1103	0.64	1147	0.69	1188	0.74	1227	0.79
1900	944	0.56	996	0.59	1045	0.63	1092	0.68	1136	0.72	1178	0.77	1218	0.82	1257	0.87
2000	986	0.63	1035	0.67	1083	0.71	1127	0.76	1170	0.81	1210	0.86	1249	0.91	1287	0.97

Air Volume cfm	External Static - in. w.g.															
	0.90		1.00		1.10		1.20		1.30		1.40		1.50		1.60	
	RPM	BHP	RPM	BHP	RPM	BHP	RPM	BHP	RPM	BHP	RPM	BHP	RPM	BHP	RPM	BHP
1200	1123	0.45	1167	0.48	1210	0.51	1251	0.55	1291	0.58	1330	0.62	1367	0.66	1403	0.70
1300	1143	0.50	1186	0.54	1228	0.57	1268	0.60	1308	0.64	1346	0.68	1382	0.72	1418	0.76
1400	1165	0.56	1206	0.59	1247	0.63	1287	0.67	1326	0.70	1363	0.75	1399	0.79	1435	0.83
1500	1188	0.62	1229	0.66	1269	0.69	1308	0.73	1346	0.77	1382	0.82	1418	0.86	1453	0.90
1600	1213	0.69	1252	0.73	1292	0.77	1330	0.81	1367	0.85	1403	0.89	1438	0.94	1472	0.98
1700	1239	0.76	1278	0.80	1316	0.84	1354	0.89	1390	0.93	1425	0.98	1459	1.02	1492	1.07
1800	1266	0.83	1304	0.88	1342	0.93	1378	0.98	1414	1.02	1448	1.07	1481	1.12	1514	1.16
1900	1294	0.92	1332	0.97	1369	1.02	1404	1.07	1439	1.12	1472	1.17	1504	1.21	1536	1.26
2000	1324	1.02	1360	1.07	1396	1.13	1431	1.18	1465	1.23	1497	1.27	1529	1.32	1560	1.37

HORIZONTAL

Air Volume cfm	External Static - in. w.g.															
	0.10		0.20		0.30		0.40		0.50		0.60		0.70		0.80	
	RPM	BHP	RPM	BHP	RPM	BHP	RPM	BHP	RPM	BHP	RPM	BHP	RPM	BHP	RPM	BHP
1200	656	0.21	726	0.24	794	0.27	858	0.30	918	0.33	973	0.37	1024	0.40	1072	0.43
1300	691	0.25	761	0.28	827	0.31	889	0.34	945	0.38	998	0.41	1047	0.45	1093	0.48
1400	731	0.29	798	0.32	862	0.35	920	0.39	974	0.42	1024	0.46	1071	0.49	1115	0.53
1500	773	0.34	838	0.37	898	0.40	952	0.44	1004	0.47	1051	0.51	1096	0.55	1139	0.58
1600	817	0.39	878	0.42	934	0.46	985	0.49	1034	0.53	1080	0.56	1123	0.60	1164	0.64
1700	861	0.45	918	0.48	970	0.51	1018	0.55	1065	0.58	1108	0.62	1150	0.66	1190	0.70
1800	904	0.51	957	0.54	1006	0.57	1052	0.61	1096	0.65	1138	0.69	1178	0.73	1217	0.78
1900	946	0.57	996	0.61	1042	0.64	1086	0.68	1128	0.72	1168	0.76	1207	0.81	1245	0.86
2000	988	0.64	1035	0.68	1079	0.72	1120	0.76	1161	0.81	1199	0.85	1237	0.90	1275	0.96

Air Volume cfm	External Static - in. w.g.															
	0.90		1.00		1.10		1.20		1.30		1.40		1.50		1.60	
	RPM	BHP	RPM	BHP	RPM	BHP	RPM	BHP	RPM	BHP	RPM	BHP	RPM	BHP	RPM	BHP
1200	1118	0.46	1163	0.48	1208	0.51	1251	0.54	1293	0.58	1334	0.61	1375	0.64	1414	0.68
1300	1137	0.51	1181	0.53	1224	0.57	1267	0.60	1309	0.63	1350	0.67	1391	0.71	1432	0.75
1400	1158	0.56	1200	0.59	1242	0.62	1284	0.66	1326	0.70	1367	0.74	1407	0.79	1448	0.83
1500	1180	0.61	1222	0.65	1263	0.69	1304	0.73	1345	0.77	1386	0.82	1427	0.87	1467	0.92
1600	1204	0.68	1245	0.72	1285	0.76	1325	0.80	1366	0.85	1406	0.90	1447	0.96	1487	1.02
1700	1229	0.75	1269	0.79	1309	0.84	1348	0.89	1388	0.94	1428	1.00	1468	1.06	1508	1.12
1800	1256	0.83	1295	0.88	1334	0.93	1373	0.98	1412	1.04	1451	1.10	1490	1.16	1529	1.23
1900	1283	0.92	1322	0.97	1360	1.03	1398	1.09	1436	1.15	1474	1.21	1511	1.27	1549	1.34
2000	1312	1.02	1350	1.07	1387	1.13	1424	1.20	1461	1.26	1498	1.32	1535	1.38	1571	1.45

BLOWER DATA

ZGD060S5B BELT DRIVE (THREE PHASE)

BLOWER TABLE INCLUDES RESISTANCE FOR BASE UNIT ONLY WITH DRY INDOOR COIL AND AIR FILTERS IN PLACE.

FOR ALL UNITS ADD:

1 - Any factory installed options air resistance (heat section, economizer, wet coil, etc.).

2 - Any field installed accessories air resistance (duct resistance, diffuser, etc.).

See page 29 for blower motors and drives and wet coil and options/accessory air resistance data.

DOWNFLOW

Air Volume cfm	External Static - in. w.g.															
	0.10		0.20		0.30		0.40		0.50		0.60		0.70		0.80	
	RPM	BHP	RPM	BHP	RPM	BHP	RPM	BHP	RPM	BHP	RPM	BHP	RPM	BHP	RPM	BHP
1600	848	0.48	905	0.53	961	0.57	1015	0.61	1064	0.66	1107	0.69	1148	0.73	1189	0.76
1700	898	0.56	952	0.60	1005	0.65	1054	0.69	1099	0.73	1140	0.77	1180	0.80	1221	0.83
1800	948	0.63	998	0.68	1047	0.73	1093	0.78	1136	0.82	1175	0.85	1214	0.88	1255	0.91
1900	996	0.72	1042	0.77	1088	0.82	1132	0.86	1173	0.90	1211	0.94	1250	0.97	1290	1.00
2000	1041	0.81	1084	0.86	1128	0.91	1170	0.95	1210	0.99	1249	1.03	1287	1.06	1326	1.10
2100	1084	0.91	1126	0.95	1168	1.00	1209	1.04	1249	1.08	1287	1.12	1324	1.17	1362	1.21
2200	1128	1.01	1169	1.05	1210	1.10	1250	1.14	1288	1.19	1326	1.23	1363	1.28	1399	1.34
2300	1173	1.11	1214	1.16	1253	1.20	1292	1.25	1329	1.30	1366	1.36	1402	1.42	1437	1.48
2400	1220	1.23	1259	1.28	1297	1.33	1335	1.38	1371	1.44	1406	1.50	1442	1.57	1476	1.63

Air Volume cfm	External Static - in. w.g.															
	0.90		1.00		1.10		1.20		1.30		1.40		1.50		1.60	
	RPM	BHP	RPM	BHP	RPM	BHP	RPM	BHP	RPM	BHP	RPM	BHP	RPM	BHP	RPM	BHP
1600	1232	0.79	1274	0.82	1316	0.86	1356	0.90	1395	0.94	1433	0.99	1470	1.04	1506	1.09
1700	1263	0.86	1304	0.90	1344	0.94	1383	0.99	1421	1.04	1458	1.09	1494	1.14	1530	1.19
1800	1295	0.95	1335	0.99	1374	1.04	1412	1.09	1448	1.14	1484	1.20	1520	1.25	1556	1.30
1900	1329	1.04	1368	1.09	1405	1.15	1441	1.20	1477	1.26	1513	1.31	1548	1.37	1583	1.42
2000	1364	1.15	1401	1.21	1437	1.27	1472	1.33	1507	1.38	1543	1.44	1578	1.49	1613	1.54
2100	1399	1.27	1435	1.33	1470	1.40	1505	1.46	1539	1.51	1574	1.56	1609	1.61	1645	1.66
2200	1435	1.40	1470	1.47	1504	1.53	1538	1.59	1573	1.65	1608	1.70	1642	1.74	1678	1.79
2300	1472	1.54	1506	1.61	1540	1.67	1574	1.73	1608	1.78	1642	1.83	1677	1.88	1712	1.93
2400	1510	1.7	1544	1.76	1577	1.82	1610	1.88	1644	1.93	1678	1.97	1713	2.02	1748	2.07

HORIZONTAL

Air Volume cfm	External Static - in. w.g.															
	0.10		0.20		0.30		0.40		0.50		0.60		0.70		0.80	
	RPM	BHP	RPM	BHP	RPM	BHP	RPM	BHP	RPM	BHP	RPM	BHP	RPM	BHP	RPM	BHP
1600	761	0.43	820	0.47	879	0.52	937	0.56	994	0.61	1045	0.65	1090	0.69	1132	0.72
1700	803	0.49	861	0.53	918	0.58	973	0.63	1025	0.67	1072	0.72	1114	0.75	1155	0.78
1800	846	0.56	901	0.60	955	0.65	1008	0.70	1056	0.75	1099	0.79	1140	0.82	1181	0.85
1900	889	0.63	941	0.68	993	0.73	1042	0.78	1087	0.83	1129	0.87	1168	0.90	1209	0.93
2000	933	0.71	981	0.76	1030	0.81	1076	0.86	1119	0.91	1159	0.95	1198	0.98	1238	1.01
2100	974	0.79	1020	0.85	1065	0.90	1109	0.96	1151	1.00	1190	1.04	1229	1.07	1268	1.11
2200	1013	0.89	1057	0.94	1100	0.99	1143	1.05	1183	1.09	1222	1.13	1261	1.17	1299	1.21
2300	1050	0.99	1093	1.04	1135	1.09	1177	1.14	1217	1.18	1255	1.23	1293	1.27	1331	1.32
2400	1088	1.09	1129	1.14	1170	1.19	1211	1.23	1250	1.28	1289	1.33	1326	1.38	1363	1.44

Air Volume cfm	External Static - in. w.g.															
	0.90		1.00		1.10		1.20		1.30		1.40		1.50		1.60	
	RPM	BHP	RPM	BHP	RPM	BHP	RPM	BHP	RPM	BHP	RPM	BHP	RPM	BHP	RPM	BHP
1600	1175	0.76	1218	0.79	1260	0.82	1302	0.85	1343	0.89	1383	0.93	1421	0.98	1458	1.03
1700	1198	0.82	1241	0.85	1283	0.89	1324	0.93	1364	0.97	1402	1.02	1439	1.07	1476	1.12
1800	1223	0.89	1265	0.92	1307	0.96	1347	1.01	1386	1.06	1423	1.11	1459	1.16	1495	1.21
1900	1250	0.96	1292	1.01	1332	1.05	1371	1.10	1408	1.15	1445	1.21	1481	1.27	1516	1.32
2000	1279	1.05	1319	1.10	1358	1.15	1396	1.20	1432	1.26	1468	1.32	1504	1.38	1539	1.44
2100	1308	1.15	1347	1.20	1385	1.26	1421	1.32	1457	1.38	1493	1.44	1528	1.50	1563	1.56
2200	1338	1.26	1376	1.31	1412	1.38	1448	1.45	1483	1.51	1518	1.57	1553	1.63	1588	1.68
2300	1368	1.37	1405	1.44	1441	1.51	1476	1.58	1510	1.64	1545	1.70	1580	1.76	1615	1.81
2400	1400	1.50	1435	1.57	1470	1.65	1505	1.72	1539	1.78	1573	1.84	1608	1.89	1643	1.94

BLOWER DATA

ZGD074S5T BELT DRIVE (THREE PHASE)

BLOWER TABLE INCLUDES RESISTANCE FOR BASE UNIT ONLY WITH DRY INDOOR COIL AND AIR FILTERS IN PLACE.

FOR ALL UNITS ADD:

1 - Any factory installed options air resistance (heat section, economizer, wet coil, etc.).

2 - Any field installed accessories air resistance (duct resistance, diffuser, etc.).

See page 29 for blower motors and drives and wet coil and options/accessory air resistance data.

DOWNFLOW

Air Volume cfm	External Static - in. w.g.															
	0.10		0.20		0.30		0.40		0.50		0.60		0.70		0.80	
	RPM	BHP	RPM	BHP	RPM	BHP	RPM	BHP	RPM	BHP	RPM	BHP	RPM	BHP	RPM	BHP
1900	578	0.44	610	0.49	643	0.54	678	0.60	714	0.65	749	0.70	785	0.76	819	0.82
2000	600	0.50	632	0.56	665	0.61	699	0.66	734	0.71	769	0.77	803	0.83	837	0.90
2100	623	0.57	655	0.62	688	0.68	721	0.73	755	0.79	789	0.84	822	0.91	854	0.98
2200	647	0.65	678	0.70	711	0.75	743	0.81	776	0.86	809	0.93	841	1.00	872	1.06
2300	671	0.73	702	0.78	734	0.83	766	0.89	798	0.95	829	1.02	860	1.09	890	1.16
2400	696	0.81	726	0.87	757	0.92	788	0.98	819	1.04	850	1.11	880	1.19	909	1.26
2500	720	0.90	750	0.95	780	1.01	811	1.07	841	1.14	871	1.22	900	1.30	929	1.37
2600	745	0.99	774	1.05	804	1.11	834	1.17	864	1.25	893	1.33	921	1.41	949	1.49
2700	770	1.09	799	1.15	828	1.21	858	1.28	887	1.36	916	1.44	943	1.53	969	1.61
2800	795	1.19	824	1.25	853	1.33	882	1.40	911	1.48	939	1.56	965	1.65	990	1.73
2900	820	1.30	849	1.37	878	1.45	907	1.53	935	1.61	962	1.70	988	1.78	1012	1.86

Air Volume cfm	External Static - in. w.g.															
	0.90		1.00		1.10		1.20		1.30		1.40		1.50		1.60	
	RPM	BHP	RPM	BHP	RPM	BHP	RPM	BHP	RPM	BHP	RPM	BHP	RPM	BHP	RPM	BHP
1900	853	0.88	885	0.94	915	0.99	944	1.05	971	1.11	996	1.17	1021	1.23	1045	1.29
2000	869	0.96	899	1.01	929	1.07	957	1.13	984	1.19	1009	1.25	1033	1.31	1058	1.38
2100	885	1.04	915	1.10	944	1.15	971	1.22	997	1.28	1022	1.34	1046	1.40	1070	1.46
2200	902	1.13	931	1.19	959	1.24	986	1.31	1012	1.37	1036	1.43	1060	1.50	1084	1.56
2300	920	1.23	948	1.29	975	1.35	1001	1.41	1027	1.47	1051	1.53	1075	1.60	1098	1.66
2400	938	1.33	965	1.39	992	1.45	1017	1.52	1042	1.58	1066	1.64	1090	1.70	1113	1.77
2500	956	1.44	983	1.51	1009	1.57	1034	1.63	1059	1.69	1082	1.75	1105	1.82	1128	1.88
2600	975	1.56	1001	1.63	1026	1.69	1051	1.75	1075	1.81	1098	1.87	1121	1.93	1143	2.00
2700	995	1.68	1020	1.75	1044	1.81	1069	1.87	1092	1.93	1114	1.99	1136	2.06	1158	2.13
2800	1015	1.81	1039	1.87	1063	1.94	1086	2.00	1109	2.06	1131	2.12	1152	2.19	1174	2.26
2900	1035	1.94	1058	2.00	1081	2.07	1104	2.13	1126	2.19	1147	2.26	1168	2.33	1189	2.40

HORIZONTAL

Air Volume cfm	External Static - in. w.g.															
	0.10		0.20		0.30		0.40		0.50		0.60		0.70		0.80	
	RPM	BHP	RPM	BHP	RPM	BHP	RPM	BHP	RPM	BHP	RPM	BHP	RPM	BHP	RPM	BHP
1900	581	0.44	618	0.49	655	0.54	692	0.59	729	0.64	765	0.69	800	0.75	833	0.80
2000	602	0.50	639	0.55	676	0.61	713	0.66	749	0.71	784	0.76	818	0.82	850	0.88
2100	625	0.57	661	0.62	698	0.67	735	0.73	770	0.78	804	0.84	837	0.90	868	0.96
2200	648	0.64	685	0.69	721	0.75	757	0.80	791	0.86	824	0.92	856	0.98	886	1.05
2300	673	0.71	709	0.77	745	0.83	780	0.88	813	0.94	845	1.01	876	1.08	905	1.15
2400	699	0.79	734	0.85	769	0.91	803	0.97	835	1.04	866	1.11	896	1.18	924	1.25
2500	725	0.88	759	0.94	793	1.00	826	1.07	857	1.14	887	1.21	916	1.28	944	1.36
2600	752	0.97	785	1.04	818	1.10	850	1.17	880	1.25	909	1.32	937	1.40	964	1.48
2700	779	1.07	811	1.14	843	1.21	873	1.29	902	1.37	931	1.44	958	1.52	984	1.60
2800	805	1.18	837	1.26	868	1.33	897	1.41	925	1.49	952	1.57	979	1.66	1004	1.74
2900	832	1.30	863	1.38	892	1.46	921	1.54	948	1.63	974	1.71	1000	1.80	1024	1.88

Air Volume cfm	External Static - in. w.g.															
	0.90		1.00		1.10		1.20		1.30		1.40		1.50		1.60	
	RPM	BHP	RPM	BHP	RPM	BHP	RPM	BHP	RPM	BHP	RPM	BHP	RPM	BHP	RPM	BHP
1900	864	0.87	895	0.93	924	0.99	953	1.06	980	1.12	1007	1.18	1032	1.25	1056	1.31
2000	881	0.95	911	1.01	940	1.08	967	1.14	994	1.21	1020	1.27	1044	1.34	1068	1.40
2100	898	1.03	927	1.10	955	1.17	982	1.23	1008	1.30	1033	1.37	1057	1.43	1080	1.50
2200	916	1.12	944	1.19	971	1.26	998	1.33	1023	1.40	1047	1.47	1071	1.54	1093	1.60
2300	934	1.22	961	1.29	988	1.36	1014	1.43	1038	1.50	1062	1.58	1085	1.65	1107	1.71
2400	952	1.32	979	1.40	1005	1.47	1030	1.54	1054	1.62	1077	1.69	1099	1.76	1121	1.83
2500	971	1.43	997	1.51	1022	1.59	1046	1.66	1069	1.74	1092	1.81	1114	1.88	1135	1.95
2600	990	1.55	1015	1.63	1039	1.71	1063	1.79	1086	1.86	1108	1.94	1129	2.01	1150	2.07
2700	1009	1.68	1034	1.76	1057	1.84	1080	1.92	1102	1.99	1124	2.07	1145	2.14	1166	2.21
2800	1028	1.82	1052	1.9	1075	1.98	1097	2.06	1119	2.13	1140	2.21	1161	2.28	1182	2.34
2900	1048	1.96	1071	2.04	1093	2.12	1115	2.20	1136	2.28	1157	2.35	1177	2.42	1198	2.48

BLOWER DATA

BELT DRIVE KIT SPECIFICATIONS - ZGD036-060

Model	Motor HP		Speeds	Drive Kits and RPM Range				
	Nominal	Maximum		ZAA01	ZAA02	ZAA03	ZAA04	¹ ZAA06
ZGD036	1	1.15	1	678 - 1035	---	---	964 - 1471	---
ZGD048	1	1.15	1	---	803 - 1226	---	---	---
ZGD060	1.5	1.7	1	---	---	906 - 1383	---	1262 - 1634

BELT DRIVE KIT SPECIFICATIONS - ZGD074

Model	Motor HP		Speeds	Drive Kits and RPM Range		
	Nominal	Maximum		ZAA02	ZAA03	ZAA04
ZGD074	2	2.3	2	632 - 875	798 - 1105	921 - 1228

NOTE - Using total air volume and system static pressure requirements determine from blower performance tables rpm and motor HP required. Maximum usable HP of motors furnished are shown. In Canada, nominal motor HP is also maximum usable motor HP. If motors of comparable HP are used, be sure to keep within the service factor limitations outlined on the motor nameplate.

POWER EXHAUST FAN PERFORMANCE

Return Air System Static Pressure - in. w.g.	Air Volume Exhausted cfm
0.00	1865
0.05	1785
0.10	1710
0.15	1630
0.20	1545
0.25	1450
0.30	1350
0.35	1240

BLOWER DATA

OPTIONS / ACCESSORIES AIR RESISTANCE - in. w.g.

Air Volume cfm	Wet Indoor Coil		Gas Heat Exchanger		Economizer	
	ZGD036, ZGD048	ZGD060, ZGD074	Medium	High	Downflow	Horizontal
900	0.01	---	0.05	0.06	0.03	0.04
1000	0.02	---	0.06	0.06	0.03	0.05
1100	0.02	---	0.06	0.07	0.04	0.05
1200	0.02	---	0.06	0.07	0.05	0.06
1300	0.03	---	0.07	0.07	0.05	0.07
1400	0.03	---	0.07	0.08	0.06	0.08
1500	0.04	---	0.07	0.08	0.07	0.08
1600	0.04	0.03	0.07	0.08	0.08	0.09
1700	0.05	0.03	0.07	0.08	0.09	0.10
1800	0.05	0.03	0.06	0.08	0.10	0.11
1900	0.06	0.04	0.06	0.08	0.11	0.12
2000	0.06	0.04	0.07	0.09	0.12	0.13
2100	---	0.05	0.08	0.10	0.13	0.14
2200	---	0.05	0.10	0.12	0.14	0.15
2300	---	0.05	0.11	0.14	0.15	0.16
2400	---	0.06	0.11	0.13	0.16	0.18
2500	---	0.06	0.11	0.15	0.18	0.19
2600	---	0.07	0.13	0.16	0.19	0.20
2700	---	0.07	0.15	0.18	0.20	0.21
2800	---	0.07	0.13	0.16	0.22	0.23
2900	---	0.08	0.13	0.18	0.23	0.24

OUTDOOR SOUND DATA

Model	Octave Band Sound Power Levels dBA, re 10 ⁻¹² Watts - Center Frequency - Hz							¹ Sound Rating Number (dBA)
	125	250	500	1000	2000	4000	8000	
ZGD036	66	70	73	72	70	67	60	78
ZGD048	68	71	75	74	71	68	63	80
ZGD060	64	68	72	73	69	67	63	78
ZGD074	73	76	80	78	73	68	66	84

NOTE - The octave sound power data does not include tonal corrections.

¹ Sound Rating Number according to AHRI Standard 270-2008. SRN is the overall A-Weighted Sound Power Level, (LWA), dBA (100 Hz to 10,000 Hz).

BLOWER DATA

CEILING DIFFUSERS AIR RESISTANCE (in. w.g.)

Air Volume cfm	RTD9-65S Step-Down Diffuser			FD9-65S Flush Diffuser	RTD11-95S Step-Down Diffuser			FD11-95S Flush Diffuser
	2 Ends Open	1 Side & 2 Ends Open	All Ends & Sides Open		2 Ends Open	1 Side & 2 Ends Open	All Ends & Sides Open	
800	0.15	0.13	0.11	0.11	---	---	---	---
1000	0.19	0.16	0.14	0.14	---	---	---	---
1200	0.25	0.20	0.17	0.17	---	---	---	---
1400	0.33	0.26	0.20	0.20	---	---	---	---
1600	0.43	0.32	0.20	0.24	---	---	---	---
1800	0.56	0.40	0.30	0.30	0.13	0.11	0.09	0.09
2000	0.73	0.50	0.36	0.36	0.15	0.13	0.11	0.10
2200	0.95	0.63	0.44	0.44	0.18	0.15	0.12	0.12
2400	---	----	---	---	0.21	0.18	0.15	0.14
2600	---	----	---	---	0.24	0.21	0.18	0.17
2800	---	----	---	---	0.27	0.24	0.21	0.20
3000	---	----	---	---	0.32	0.29	0.25	0.25
3200	---	----	---	---	0.41	0.37	0.32	0.31
3400	---	----	---	---	0.50	0.45	0.39	0.37
3600	---	----	---	---	0.61	0.54	0.48	0.44

CEILING DIFFUSER AIR THROW DATA

Air Volume - cfm	¹ Effective Throw - ft.		Air Volume - cfm	¹ Effective Throw - ft.	
Model	RTD9-65S	FD9-65S	Model	RTD11-95S	FD11-95S
800	10 - 17	14 - 18	2600	24 - 29	19 - 24
1000	10 - 17	15 - 20	2800	25 - 30	20 - 28
1200	11 - 18	16 - 22	3000	27 - 33	21 - 29
1400	12 - 19	17 - 24	3200	28 - 35	22 - 29
1600	12 - 20	18 - 25	3400	30 - 37	22 - 30
1800	13 - 21	20 - 28	3600	25 - 33	22 - 24
2000	14 - 23	21 - 29			
2200	16 - 25	22 - 30			

¹ Effective throw based on terminal velocities of 75 ft. per minute.

ELECTRICAL DATA **DIRECT DRIVE | 3 TON**

Model		ZGD036S5E	
¹ Voltage - 60Hz		208/230V-1 Ph	208/230V-3 Ph
Compressor (Non-Inverter)	Rated Load Amps	14.4	9
	Locked Rotor Amps	86	70
Outdoor Fan Motor	Full Load Amps (1 Non-ECM)	1.7	1.7
Power Exhaust (1) 0.33 HP	Full Load Amps	2.4	2.4
Indoor Blower Motor	HP	0.5	0.5
	Type	ECM Direct	ECM Direct
	Full Load Amps	4.3	4.3
² Maximum Overcurrent Protection (MOCP)	Unit Only	35	25
	With (1) 0.33 HP Power Exhaust	40	25
³ Minimum Circuit Ampacity (MCA)	Unit Only	24	18
	With (1) 0.33 HP Power Exhaust	27	20

ELECTRICAL DATA **DIRECT DRIVE | 4 TON**

Model		ZGD048S5E	
¹ Voltage - 60Hz		208/230V-1 Ph	208/230V-3 Ph
Compressor (Non-Inverter)	Rated Load Amps	19.4	12
	Locked Rotor Amps	102	123
Outdoor Fan Motor	Full Load Amps (1 Non-ECM)	1.7	1.7
Power Exhaust (1) 0.33 HP	Full Load Amps	2.4	2.4
Indoor Blower Motor	HP	0.75	0.75
	Type	ECM Direct	ECM Direct
	Full Load Amps	6.1	6.1
² Maximum Overcurrent Protection (MOCP)	Unit Only	50	30
	With (1) 0.33 HP Power Exhaust	50	35
³ Minimum Circuit Ampacity (MCA)	Unit Only	33	23
	With (1) 0.33 HP Power Exhaust	35	26

ELECTRICAL DATA **DIRECT DRIVE | 5 TON**

Model		ZGD060S5E	
¹ Voltage - 60Hz		208/230V-1 Ph	208/230V-3 Ph
Compressor (Non-Inverter)	Rated Load Amps	23.7	16
	Locked Rotor Amps	157	156.4
Outdoor Fan Motor	Full Load Amps (1 Non-ECM)	1.7	1.7
Power Exhaust (1) 0.33 HP	Full Load Amps	2.4	2.4
Indoor Blower Motor	HP	1	1
	Type	ECM Direct	ECM Direct
	Full Load Amps	7.4	7.4
² Maximum Overcurrent Protection (MOCP)	Unit Only	60	45
	With (1) 0.33 HP Power Exhaust	60	45
³ Minimum Circuit Ampacity (MCA)	Unit Only	39	30
	With (1) 0.33 HP Power Exhaust	42	32

NOTE - All units have a minimum Short Circuit Current Rating (SCCR) of 5000 amps.

¹ Extremes of operating range are plus and minus 10% of line voltage.

² HACR type breaker or fuse.

³ Refer to National or Canadian Electrical Code manual to determine wire, fuse and disconnect size requirements.

ELECTRICAL DATA		BELT DRIVE 3 TON		
Model		ZGD036S5B		
¹ Voltage - 60Hz		208/230V - 3 Ph	460V - 3 Ph	575V - 3 Ph
Compressor (Non-Inverter)	Rated Load Amps	9	4.1	3.3
	Locked Rotor Amps	70	39	29
Outdoor Fan Motor	Full Load Amps (1 Non-ECM)	1.7	0.9	0.7
Power Exhaust (1) 0.33 HP	Full Load Amps	2.4	1.3	1
Indoor Blower Motor	HP	1	1	1
	Type	Belt	Belt	Belt
	Full Load Amps	4.6	2.1	1.7
² Maximum Overcurrent Protection (MOCP)	Unit Only	25	15	15
	With (1) 0.33 HP Power Exhaust	25	15	15
³ Minimum Circuit Ampacity (MCA)	Unit Only	18	9	7
	With (1) 0.33 HP Power Exhaust	20	10	8

ELECTRICAL DATA		BELT DRIVE 4 TON		
Model		ZGD048S5B		
¹ Voltage - 60Hz		208/230V - 3 Ph	460V - 3 Ph	575V - 3 Ph
Compressor (Non-Inverter)	Rated Load Amps	12	6.3	4.4
	Locked Rotor Amps	123	60	41
Outdoor Fan Motor	Full Load Amps (1 Non-ECM)	1.7	0.9	0.7
Power Exhaust (1) 0.33 HP	Full Load Amps	2.4	1.3	1
Indoor Blower Motor	HP	1	1	1
	Type	Belt	Belt	Belt
	Full Load Amps	4.6	2.1	1.7
² Maximum Overcurrent Protection (MOCP)	Unit Only	30	15	15
	With (1) 0.33 HP Power Exhaust	35	15	15
³ Minimum Circuit Ampacity (MCA)	Unit Only	22	11	8
	With (1) 0.33 HP Power Exhaust	24	13	9

ELECTRICAL DATA		BELT DRIVE 5 TON		
Model		ZGD060S5B		
¹ Voltage - 60Hz		208/230V - 3 Ph	460V - 3 Ph	575V - 3 Ph
Compressor (Non-Inverter)	Rated Load Amps	13.5	7.1	6.4
	Locked Rotor Amps	109	69	47.8
Outdoor Fan Motor	Full Load Amps (1 Non-ECM)	1.7	0.9	0.7
Power Exhaust (1) 0.33 HP	Full Load Amps	2.4	1.3	1
Indoor Blower Motor	HP	1.5	1.5	1.5
	Type	Belt	Belt	Belt
	Full Load Amps	4.4	2.3	2.3
² Maximum Overcurrent Protection (MOCP)	Unit Only	40	15	15
	With (1) 0.33 HP Power Exhaust	40	20	15
³ Minimum Circuit Ampacity (MCA)	Unit Only	27	13	11
	With (1) 0.33 HP Power Exhaust	29	14	12

NOTE - All units have a minimum Short Circuit Current Rating (SCCR) of 5000 amps.

¹ Extremes of operating range are plus and minus 10% of line voltage.

² HACR type breaker or fuse.

³ Refer to National or Canadian Electrical Code manual to determine wire, fuse and disconnect size requirements.

ELECTRICAL DATA**BELT DRIVE | 6 TON**

Model		ZGD074S5T		
¹ Voltage - 60Hz		208/230V - 3 Ph	460V - 3 Ph	575V - 3 Ph
Compressor (Non-Inverter)	Rated Load Amps	19.2	9.1	6.2
	Locked Rotor Amps	162.3	70.8	58.2
Outdoor Fan Motor	Full Load Amps (1 Non-ECM)	1.7	1	0.9
Power Exhaust (1) 0.33 HP	Full Load Amps	2.4	1.3	1
Indoor Blower Motor	HP	2	2	2
	Type	Belt	Belt	Belt
	Full Load Amps	7.5	3.4	2.7
² Maximum Overcurrent Protection (MOCP)	Unit Only	50	20	15
	With (1) 0.33 HP Power Exhaust	50	25	15
³ Minimum Circuit Ampacity (MCA)	Unit Only	34	16	12
	With (1) 0.33 HP Power Exhaust	36	18	13

NOTE - All units have a minimum Short Circuit Current Rating (SCCR) of 5000 amps.

¹ Extremes of operating range are plus and minus 10% of line voltage.

² HACR type breaker or fuse.

³ Refer to National or Canadian Electrical Code manual to determine wire, fuse and disconnect size requirements.

FIELD WIRING NOTES

- For use with copper wiring only
- Field wiring not furnished
- All wiring must conform to NEC or CEC and local electrical codes
- For specific wiring information, please refer to the installation instructions

UNIT CLEARANCES

UNIT WITH DOWNFLOW ECONOMIZER

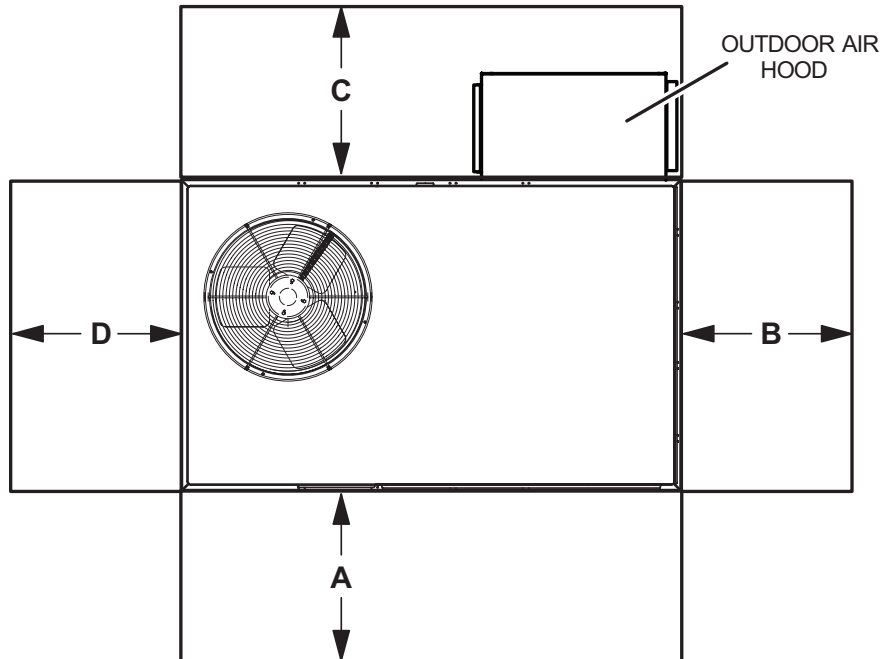

UNIT WITH HORIZONTAL ECONOMIZER

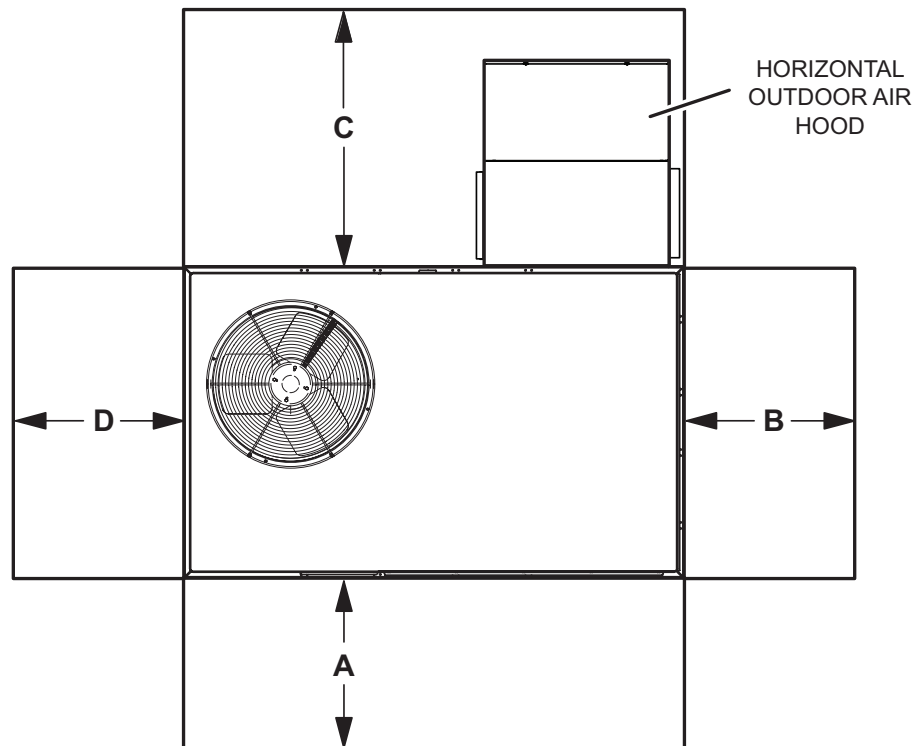

1 Unit Clearance	A		B		C Downflow		C Horizontal		D		Top Clearance
	in.	mm	in.	mm	in.	mm	in.	mm	in.	mm	
Service Clearance	36	914	36	914	36	914	60	1524	36	914	Unobstructed
Clearance to Combustibles	36	914	1	25	1	25	1	25	1	25	
Minimum Operation Clearance	36	914	36	914	36	914	60	1524	36	914	

NOTE - Entire perimeter of unit base requires support when elevated above the mounting surface.

¹ Service Clearance - Required for removal of serviceable parts.

Minimum Operation Clearance - Required clearance for proper unit operation.

WEIGHT DATA

Model	Net				Shipping			
	Base		Max.		Base		Max.	
	lbs.	kg	lbs.	kg	lbs.	kg	lbs.	kg
ZGD036S	524	238	594	269	529	240	599	272
ZGD048S	533	242	603	274	538	244	608	276
ZGD060S	592	269	664	301	597	271	669	303
ZGD074S	640	290	712	323	645	293	717	325

Base Unit - The unit with standard heat exchanger NO OPTIONS.

Max. Unit - The unit with ALL OPTIONS Installed. (High Input Heat Exchanger, Economizer, etc.)

FACTORY / FIELD INSTALLED OPTIONS AND ACCESSORIES - NET WEIGHTS

Description	lbs.	kg	
ECONOMIZER / OUTDOOR AIR / EXHAUST			
Economizer			
Downflow	75	34	
Horizontal	102	46	
Outdoor Air Dampers			
Motorized	39	18	
Manual	29	13	
Power Exhaust			
Downflow	54	24	
Horizontal	41	19	
GAS HEAT			
Medium Heat (adder over standard heat)	8	4	
High Heat (adder over standard heat)	19	9	
COMBINATION COIL/HAIL GUARDS			
036/048	45	20	
060/074	50	23	
ROOF CURBS			
Hybrid Roof Curbs, Downflow			
8 in. height	63	29	
14 in. height	83	38	
18 in. height	93	42	
24 in. height	113	51	
CEILING DIFFUSERS			
Step-Down	RTD9-65S	80	36
	RTD11-95S	118	54
Flush	FD9-65S	80	36
	FD11-95S	118	54

DIMENSIONS - UNIT

Size	CORNER WEIGHTS																CENTER OF GRAVITY							
	AA		BB				CC				DD				EE				FF					
	Base	Max.	Base	Max.	Base	Max.	Base	Max.	Base	Max.	Base	Max.	Base	Max.	Base	Max.	Base	Max.						
	lbs.	kg	lbs.	kg	lbs.	kg	lbs.	kg	lbs.	kg	lbs.	kg	in.	mm	in.	mm	in.	mm						
036	129	59	147	67	124	56	141	64	133	60	150	68	138	63	156	71	38.75	984	36.75	933	22.75	578	24.5	622
048	132	60	149	68	126	57	143	65	135	61	152	69	140	64	159	72	38.75	984	36.75	933	22.75	578	24.5	622
060	162	73	182	83	146	66	164	74	134	61	151	68	149	68	167	76	40	1016	38	965	24.5	622	26	660
074	153	69	170	77	153	69	170	77	167	76	186	84	167	76	186	84	38	965	36	914	22.5	572	24	610

Base Unit - The unit with NO OPTIONS.

Max. Unit - The unit with ALL OPTIONS Installed. (Economizer, largest blower motor, etc.).

BOTTOM POWER ENTRY

Holes required for Optional Bottom Power Entry Kit

	Threaded Conduit Fittings (Provided in Kit)	Wire Use	Hole Diameter Required in Unit Base (Max.)
A	1/2	ACC	7/8 (23)
B	1/2	24V	7/8 (23)
C	3/4	POWER	1-1/8 (29)

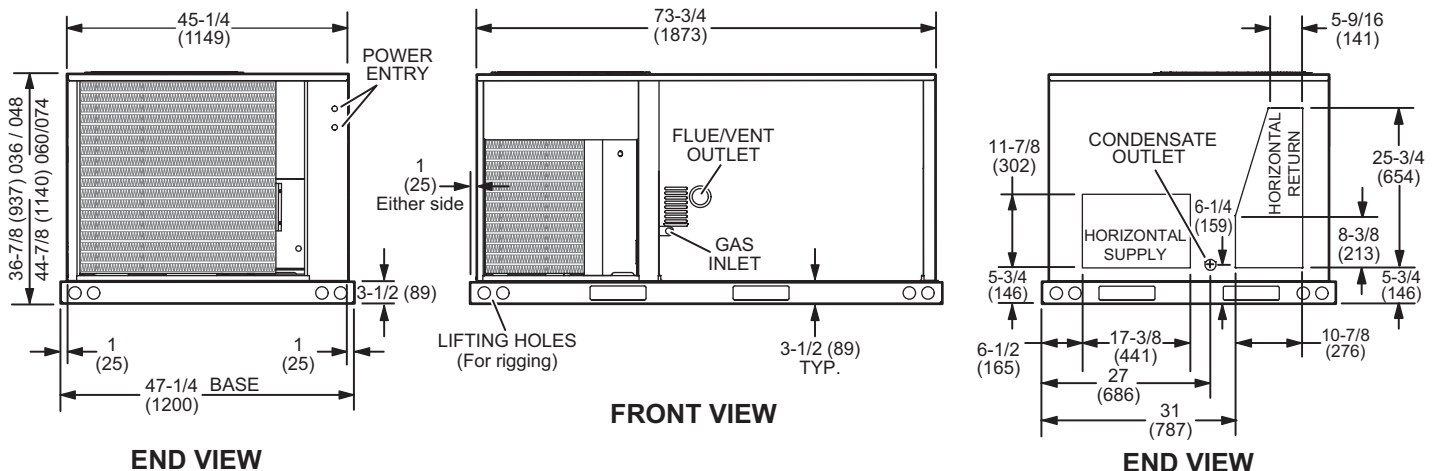
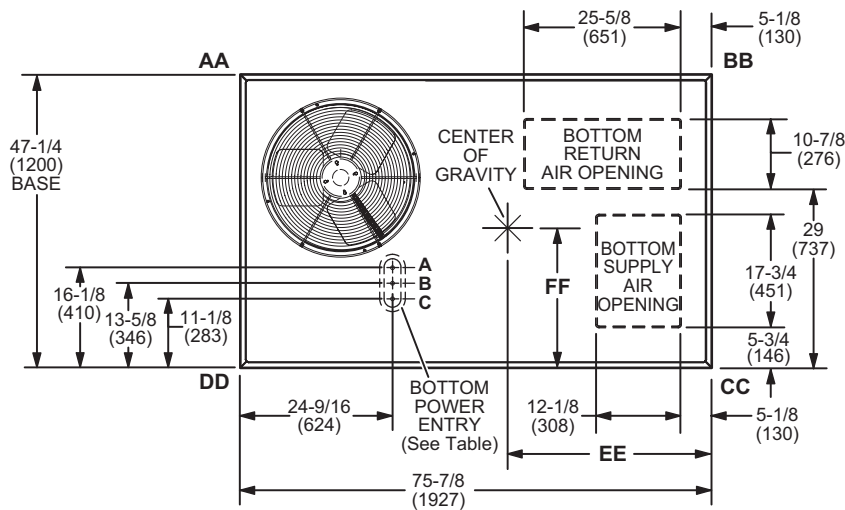

DIMENSIONS - ACCESSORIES

OUTDOOR AIR HOOD DETAIL FOR OPTIONAL ECONOMIZER (Downflow Applications)

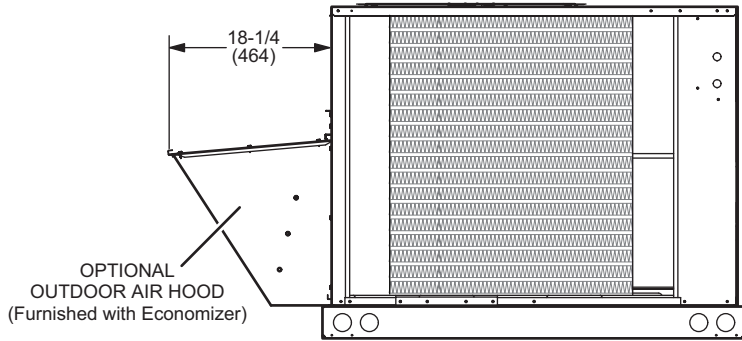

SIDE VIEW

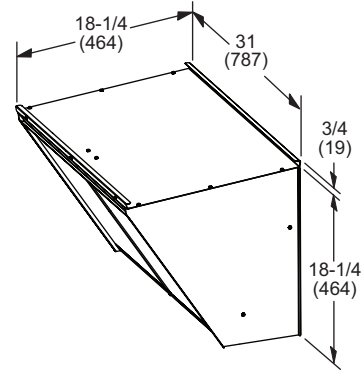

OUTDOOR AIR DAMPER HOOD DETAIL (Downflow or Horizontal Applications)

MANUAL OUTDOOR AIR HOOD

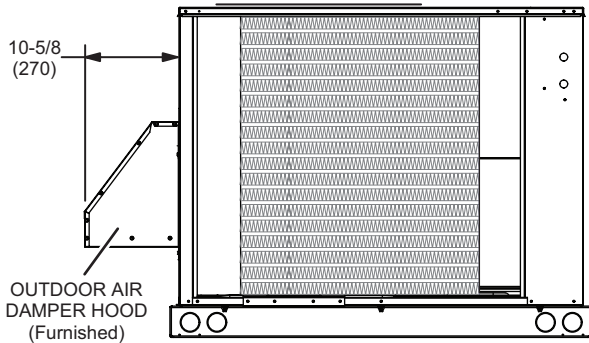

END VIEW

MOTORIZED OUTDOOR AIR HOOD

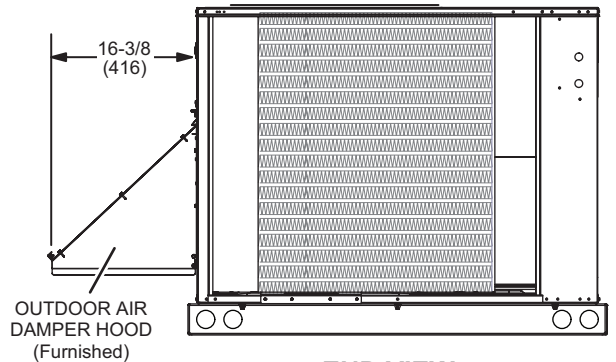

END VIEW

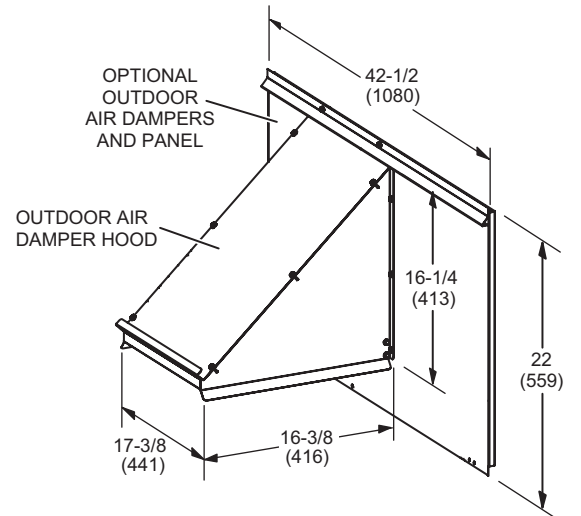
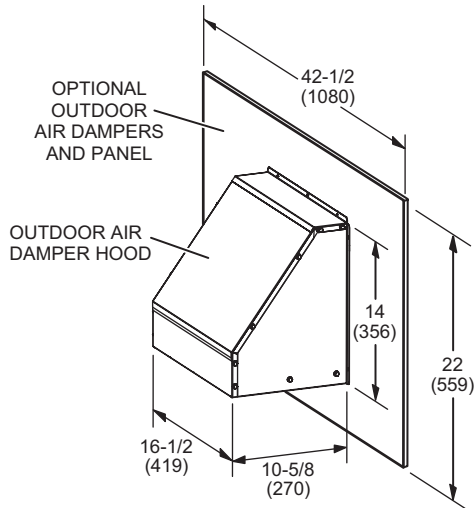

DIMENSIONS - ACCESSORIES

**OUTDOOR AIR HOOD DETAIL WITH OPTIONAL ECONOMIZER AND BAROMETRIC RELIEF DAMPERS
(Horizontal Applications)**

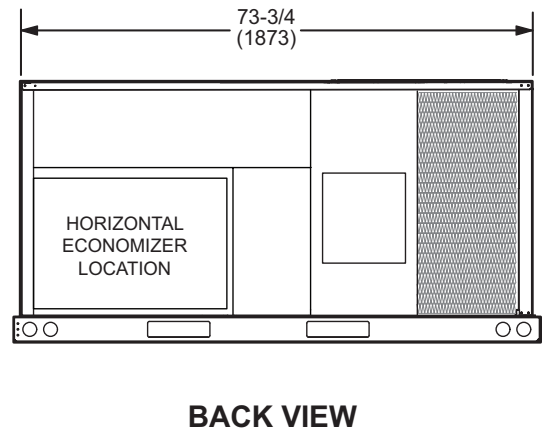
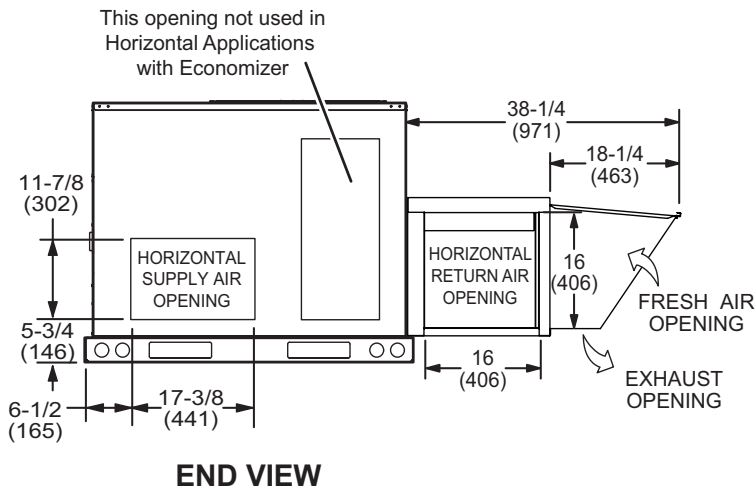
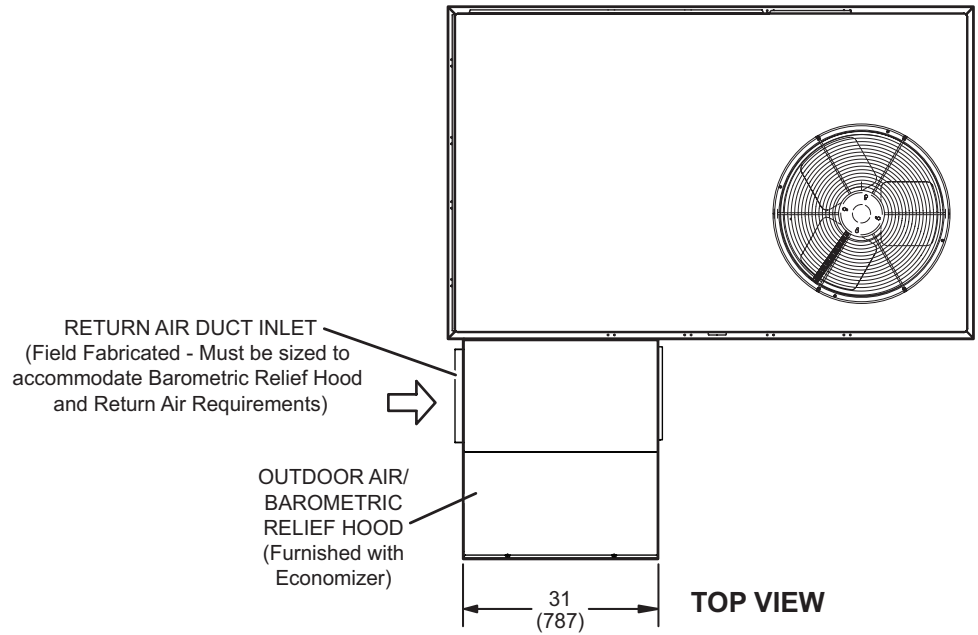

Note - Return Air Duct and Transition must be supported.

DIMENSIONS - ACCESSORIES

HYBRID ROOF CURBS - DOUBLE DUCT OPENING

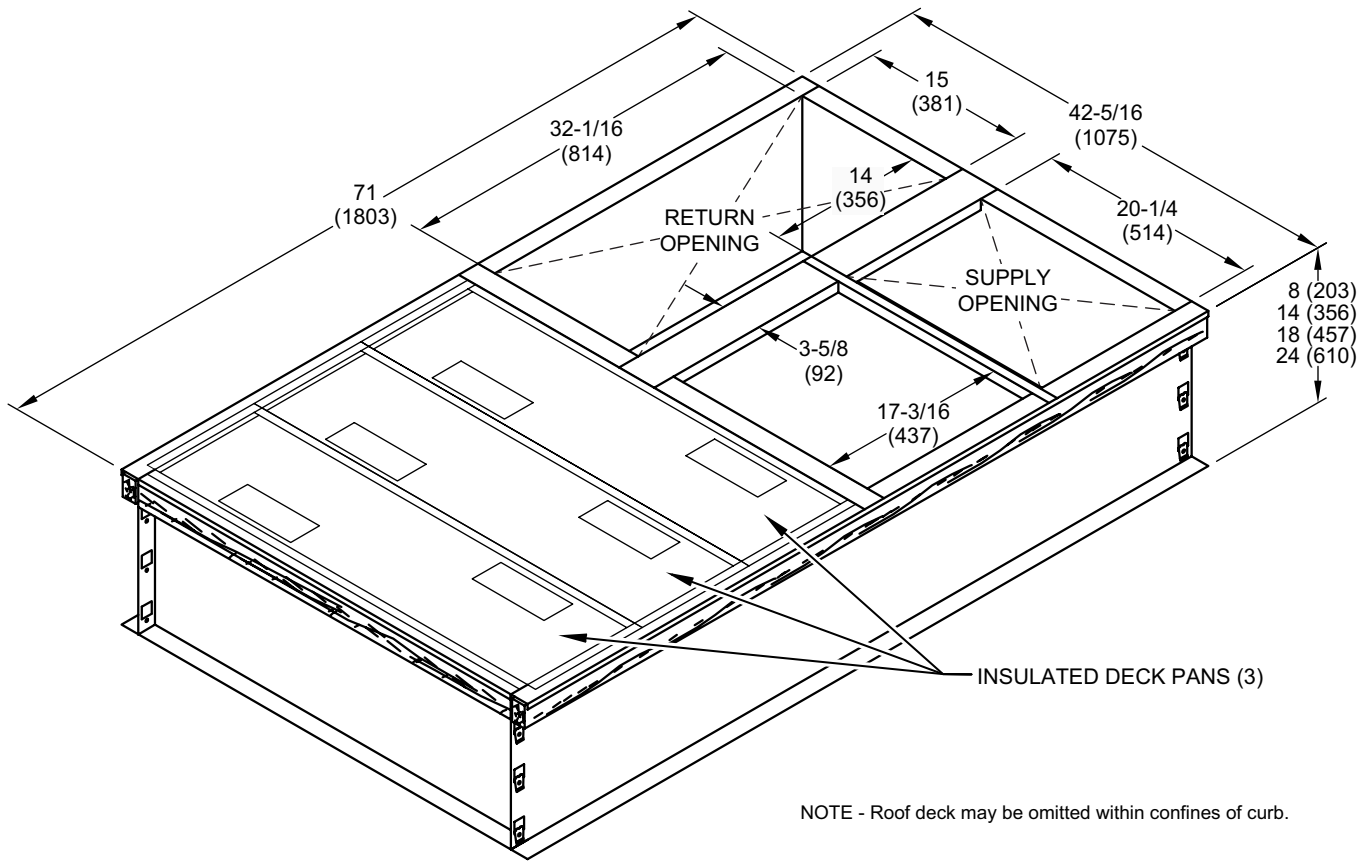

TYPICAL FLASHING DETAIL FOR ROOF CURB

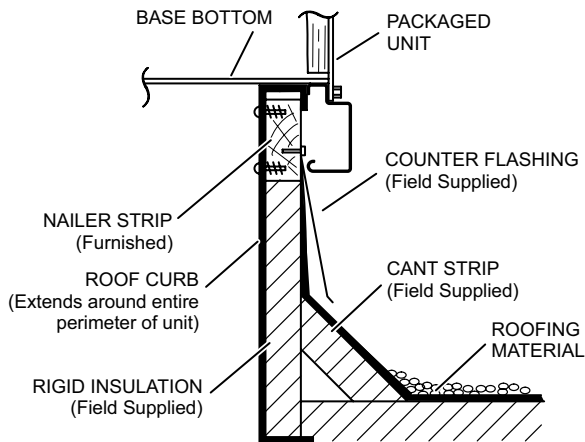

DETAIL ROOF CURB

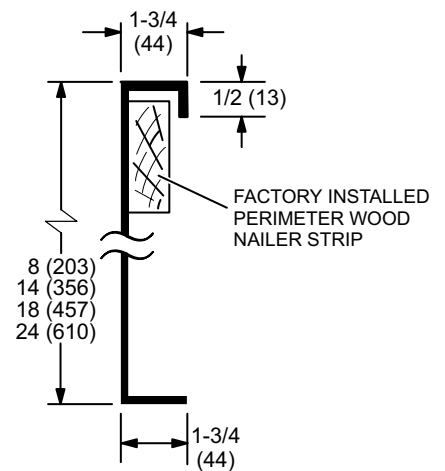

DIMENSIONS - ACCESSORIES

COMBINATION CEILING SUPPLY AND RETURN DIFFUSERS

STEP-DOWN CEILING DIFFUSER

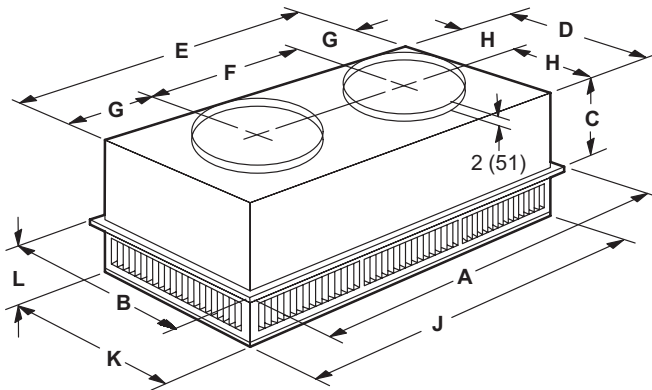

Model		RTD9-65S	RTD11-95S
A	in.	47-5/8	47-5/8
	mm	1159	1159
B	in.	23-5/8	29-5/8
	mm	600	752
C	in.	11-3/8	14-3/8
	mm	289	365
D	in.	21-1/2	27-1/2
	mm	546	699
E	in.	45-1/2	45-1/2
	mm	1156	1158
F	in.	22-1/2	22-1/2
	mm	572	572
G	in.	11-1/2	11-1/2
	mm	292	292
H	in.	10-3/4	13-3/4
	mm	273	349
J	in.	45-1/2	45-1/2
	mm	1156	1156
K	in.	21-1/2	27-1/2
	mm	546	699
L	in.	7-1/8	8-1/8
	mm	181	206
Duct Size	in.	18 round	20 round
	mm	457 round	508 round

FLUSH CEILING DIFFUSER

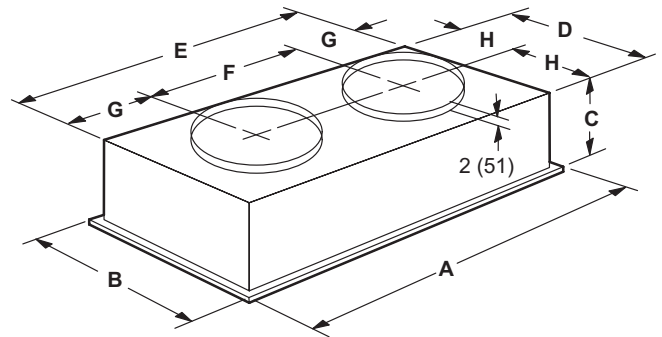

Model		FD9-65S	FD11-95S
A	in.	47-5/8	47-5/8
	mm	1159	1159
B	in.	23-5/8	29-5/8
	mm	600	752
C	in.	13-1/2	16-5/8
	mm	343	422
D	in.	21	27
	mm	533	686
E	in.	45	45
	mm	1143	1143
F	in.	22-1/2	22-1/2
	mm	572	572
G	in.	11-1/4	11-1/4
	mm	286	286
H	in.	10-1/2	13-1/2
	mm	267	343
Duct Size	in.	18 round	20 round
	mm	457 round	508 round



Visit us at www.allied-commercial.com

For the latest technical information, visit us at www.allied-commercial.com

Contact us at 1-800-448-5872

NOTE - Due to Allied Commercial ongoing commitment to quality, Specifications, Ratings and Dimensions subject to change without notice and without incurring liability. Improper installation, adjustment, alteration, service or maintenance can cause property damage or personal injury. Installation and service must be performed by a qualified installer and servicing agency.