

# COMMERCIAL SPLIT SYSTEM KITS AND ACCESSORIES

507776-02  
9/2022

## ECONOMIZERS

### INSTALLATION INSTRUCTIONS FOR ECONOMIZERS USED WITH ELA / ELXA SERIES UNITS

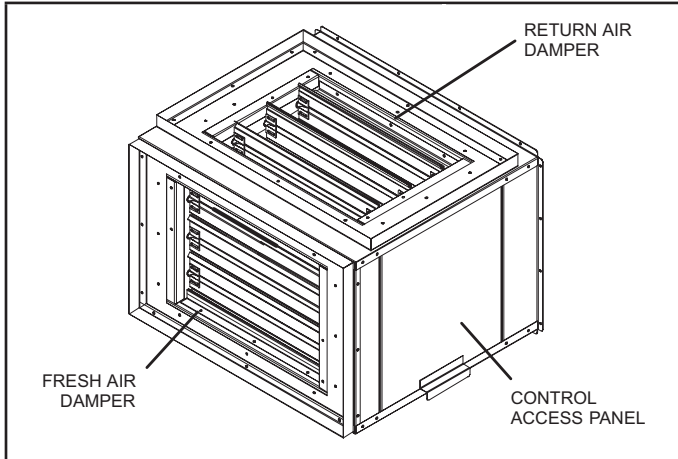

**RETAIN THESE INSTRUCTIONS FOR FUTURE REFERENCE**

#### **⚠ WARNING**

Improper installation, adjustment, alteration, service or maintenance can cause property damage, personal injury or loss of life. Installation and service must be performed by a licensed professional HVAC installer or equivalent, service agency, or the gas supplier.

#### **⚠ CAUTION**

As with any mechanical equipment, contact with sharp sheet metal edges can result in personal injury. Take care while handling this equipment and wear gloves and protective clothing.

#### **⚠ WARNING**



**Electric Shock Hazard!** – Disconnect all power supplies before servicing. Replace all parts and panels before operating. Failure to do so can result in death or electrical shock.

#### Shipping and Packing List

Check parts for shipping damage; if any damage is found, immediately contact the last shipping carrier.

Package 1 of 1 contains:

1 – Economizer assembly

1 – Bag assembly containing:

- Outdoor air sensor (A7 for std. economizers, RT26 for high performance economizers)
- Mixed air sensor
- 18- #10-16 x 1/2 SDST screws
- Title 24 certificate
- Honeywell control manual
- 8- #10-16 x 1 screws

1 – Insulated filler panel

#### Application

Economizers are used for automatic sensor-controlled introduction of outdoor air into the system through an electro-mechanically controlled damper. See table 1 for usage.

**TABLE 1. Application**

Unit	Part #	Economizer Control
072, 090	17A10 / 105277-01	Std. - W7212
120, 150	17A11 / 105277-02	Std. - W7212
180, 240	17A12 / 105277-03	Std. - W7212
072, 090	20V20 / 105277-07	Hi Performance - W7220
120, 150	20V21 / 105277-08	Hi Performance - W7220
180, 240	20V22 / 105277-09	Hi Performance - W7220

Economizers are used with ELA/ELXA units in upflow and horizontal air discharge applications. Economizer dampers will modulate to maintain 55°F (13°C) supply air when outdoor air is suitable. The mixed air temperature sensor (R1) measures the supply air sensible temperature.

On standard economizers, an outdoor enthalpy sensor (A7) is used to determine whether outdoor air is suitable for free cooling. On high performance economizers, sensible sensor (RT26) is used to determine whether outdoor air is suitable for free cooling. Other outdoor and return air (OA and RA) sensor options are available to determine whether outdoor air is suitable for free cooling.

For differential control, install the second outdoor air sensor in the return air as shown in figure 4. See table 2 and the instructions provided with optional sensors.

The mixed air sensor (R1) and outdoor air sensor (A7 or RT26) are provided with the economizer and installed according to these instructions.

**TABLE 2. Sensors**

<b>Sensors</b>	<b>Dampers modulate to maintain 55°F mixed air (R1) when:</b>
Single Outside Air (OA) Sensible	OA temperature (RT26) is lower than free cooling setpoint.
Single Outside Air (OA) Enthalpy	OA temperature and humidity (A7) is lower than free cooling setpoint.
Differential Sensible - 1 in OA and 1 in RA	OA temperature (RT26) is lower than return air (RA) temperature (RT27).
Differential Enthalpy -1 in OA and 1 in RA*	OA temperature and humidity (A7) is lower than RA temperature and humidity (A62).

**Table of Contents**

General .....2  
 Std. and High Performance Economizer Dimensions ...3  
 Economizer Installation .....3  
 Economizer Wiring Connections .....7  
 High Performance Economizer Sensor Connections ....8  
 Standard Economizer – A6 Control ..... 11  
 Damper Minimum Position Setting .....12  
 Standard Economizer – System Check ..... 14  
 Standard Economizer – Operation ..... 14  
 High Performance Economizer – A6 Control ..... 14  
 High Performance Economizer – Settings ..... 15  
 High Performance Economizer – Sequence of Operation 17  
 Maintenance ..... 18

**General**

**Standard Economizer**

The standard economizer is equipped with a W7212 economizer control module A6. The default outdoor enthalpy sensor (A7) is provided in this kit. Install sensor as close as possible to inlet of incoming outdoor air.

**High Performance Economizer**

The high performance economizer is equipped with a W7220 control module A6. The default outdoor air sensor (RT26) is provided in this kit. Install sensor as close as possible to inlet of incoming outdoor air. This application provides low leak, fault detection and diagnostic capabilities. The default OA temperature sensor or high limit sensor (RT26) is a CEC approved, California Title 24 fixed dry bulb device (provided in this kit). See table 2 for outdoor and return air (OA and RA) sensor options. Refer to manufacturer’s instructions provided for more details.

**IAQ Sensing (A63)**

An IAQ sensor is used when demand control ventilation (DCV) is specified. Damper minimum position can be set lower than traditional minimum air requirements resulting in cost savings. The IAQ sensor allows the A6 to open dampers to traditional ventilation requirements as room occupancy (CO2) increases. For proper operation, the IAQ sensor must provide a 2-10VDC, 100 ohm impedance signal. Connect sensor leads to wires in control box labeled IAQ and IAQ-COM.

## Std. and High Performance Economizer Dimensions

NOTE- ECONOMIZER SECTION MAY BE ROTATED 180° FOR BOTTOM RETURN AIR CONNECTION.

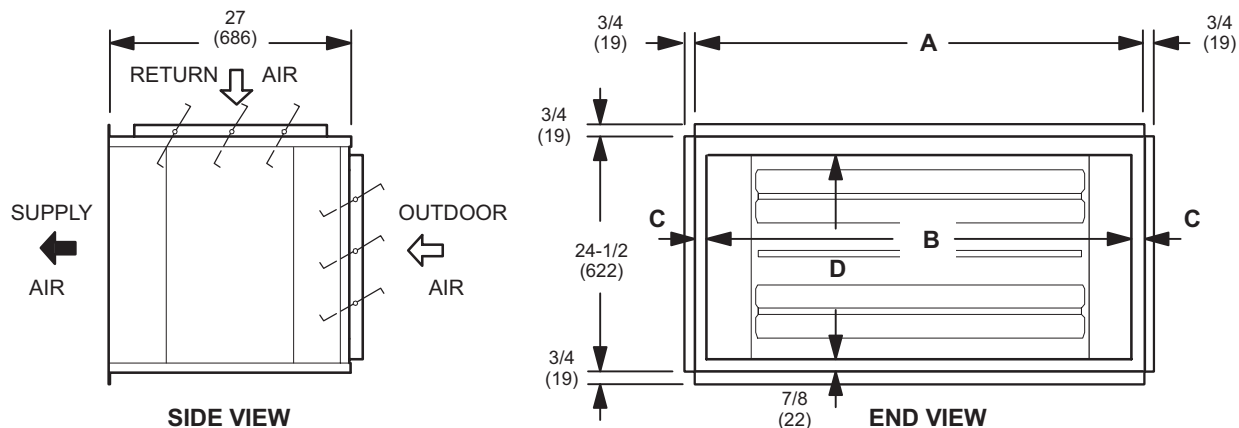

Model No. (Air Handler Usage)	A		B		C		D	
	in.	mm	in.	mm	in.	mm	in.	mm
A2ECON31L-1 / A2ECON31L-1- (072-090)	32	813	30	762	1	25	20-1/2	521
A2ECON31M-1 / A2ECON31M-1- (120-150)	51-1/2	1308	45	1143	3-1/4	83	20-1/2	521
A2ECON31N-1 / A2ECON31N-1- (180-240)	72	1829	60	1524	6	152	20-1/2	521
A2ECON34L-1 / A2ECON31L-1- (072-090)	32	813	30	762	1	25	20-1/4	514
A2ECON34M-1 / A2ECON31M-1- (120-150)	51-1/2	1308	45	1143	3-1/4	83	20-1/4	514
A2ECON34N-1 / A2ECON31N-1- (180-240)	72	1829	60	1524	6	152	20-1/4	514

## Economizer Installation

### UPFLOW OR HORIZONTAL APPLICATIONS

- 1 - Disconnect all power to the unit.
- 2 - Determine the application (upflow or horizontal).
- 3 - Attach economizer over filter rack, attached to the return air opening, with screws provided (figure 2).

**NOTE** – While attaching the economizer, make sure the control access panel is easily accessible. Preferably attach the economizer in such a way that that the end with control access panel is flush with one end of the filter rack.

- 4 - Remove control access panel on both the economizer and ELA/ELXA unit.

**NOTE** – Ensure the mixed air sensor is mounted downstream of evaporator.

- 5 - Remove and discard existing P3 jumper plug from J3 jack on unit wiring harness (figure 3).
- 6 - Connect economizer wiring harness connector P4 into air handler jack J3.

## **⚠ WARNING**

Do not connect economizer plug P4 to air handler J2 when using a temperature control system. Control damage could result. See control wiring diagram for proper jack/plug connections.

- 7 - Use wire ties to secure excess wire.
- 8 - Install outdoor air sensor (A7 or RT26) as close as possible to inlet of outdoor air.

9 - *Std. Economizer Installations –*

Route wires marked SO and SO+ from economizer to A7 enthalpy sensor. Make wiring connections as shown in figure 4. Connect P and P1 from A6 Controller to P and P1 on A183. Harness is provided.

*High Performance Installations –*

Route wires marked OAT from economizer to RT26 outdoor air sensor. Make wiring connections as shown in figure 4.

- 10 - Install mixed air sensor as shown in figure 4.

11 - *Std. Economizer Installations –*

Route black wires (marked T and T1) from economizer to R1 mixed air sensor. Make wiring connections as shown in figure 4.

*High Performance Installations –*

Route plug with two wires from economizer to R1 mixed air sensor. Make wiring connections as shown in figure 4.

- 12 - Replace control access panel on economizer and unit.

- 13 - Install the insulated filler panels with the screws provided to cover the return air opening after the economizer has been securely installed.

**NOTE** – *Holes provided on only one side of the filler plate. Other end needs to be secured in the field by selecting holes in appropriate location.*

- 14 - Place return and fresh air ducts to economizer and seal air tight.

**NOTE** – *Economizer section may be rotated 180° for bottom return air connections (figure 3).*

- 15 - Restore power to the unit.

### UPFLOW CONFIGURATION

**NOTE** - Economizer and air handler must be properly supported.

INSTALL RETURN AIR ENTHALPY SENSOR (A62) OR RETURN AIR SENSOR (RT27) INSIDE THE RETURN AIR DUCT. MAKE SURE THE SENSOR DOES NOT BLOCK DAMPER MOVEMENT.

INSTALL OUTDOOR AIR SENSOR (RT26) OR OUTDOOR AIR ENTHALPY SENSOR (A7) INSIDE THE OUTDOOR AIR DUCT. LOCATE THE SENSOR AS CLOSE TO THE OUTDOOR AIR INLET AS POSSIBLE. MAKE SURE THE SENSOR DOES NOT BLOCK DAMPER MOVEMENT.

INSTALL MIXED AIR SENSOR (R1) IN THIS GENERAL LOCATION TO MEASURE SUPPLY AIR SENSIBLE TEMPERATURE

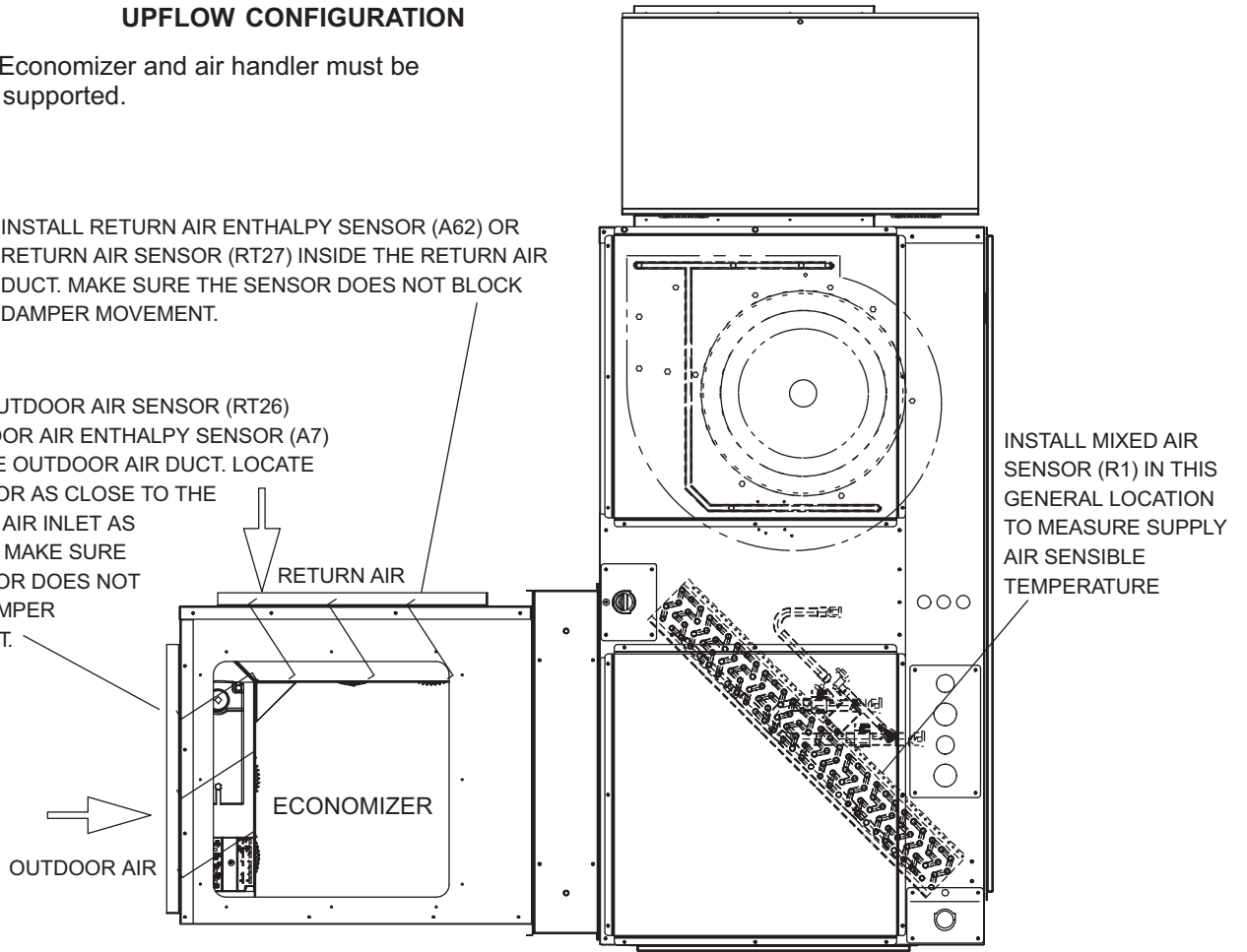

### HORIZONTAL CONFIGURATION

INSTALL MIXED AIR SENSOR (R1) IN THIS GENERAL LOCATION TO MEASURE SUPPLY AIR SENSIBLE TEMPERATURE

INSTALL RETURN AIR ENTHALPY SENSOR (A62) OR RETURN AIR SENSOR (RT27) INSIDE THE RETURN AIR DUCT. MAKE SURE THE SENSOR DOES NOT BLOCK DAMPER MOVEMENT.

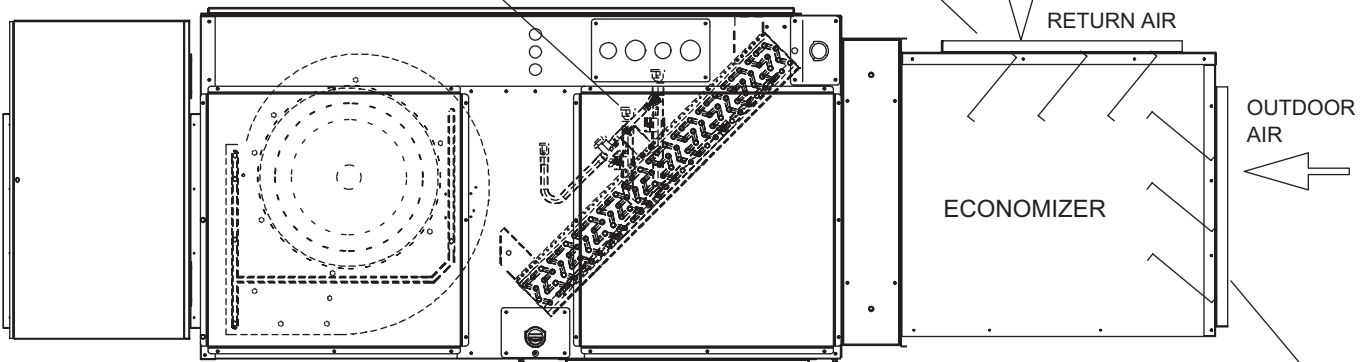

**NOTE** - Economizer and air handler must be properly supported.

INSTALL OUTDOOR AIR SENSOR (RT26) OR OUTDOOR AIR ENTHALPY SENSOR (A7) INSIDE THE OUTDOOR AIR DUCT. LOCATE THE SENSOR AS CLOSE TO THE OUTDOOR AIR INLET AS POSSIBLE. MAKE SURE THE SENSOR DOES NOT BLOCK DAMPER MOVEMENT.

**FIGURE 1. Upflow and Horizontal Applications**

**UPFLOW APPLICATION**

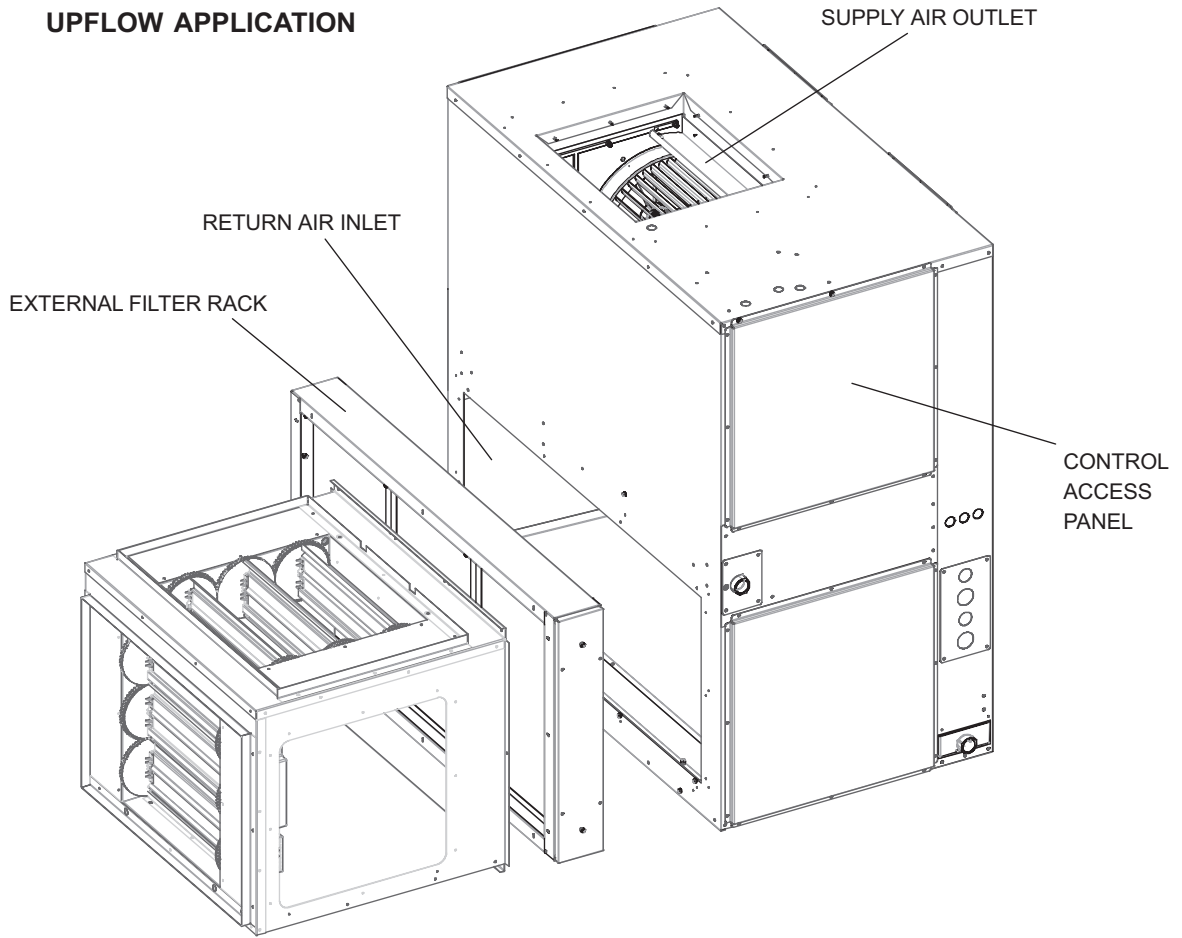

**HORIZONTAL APPLICATION**

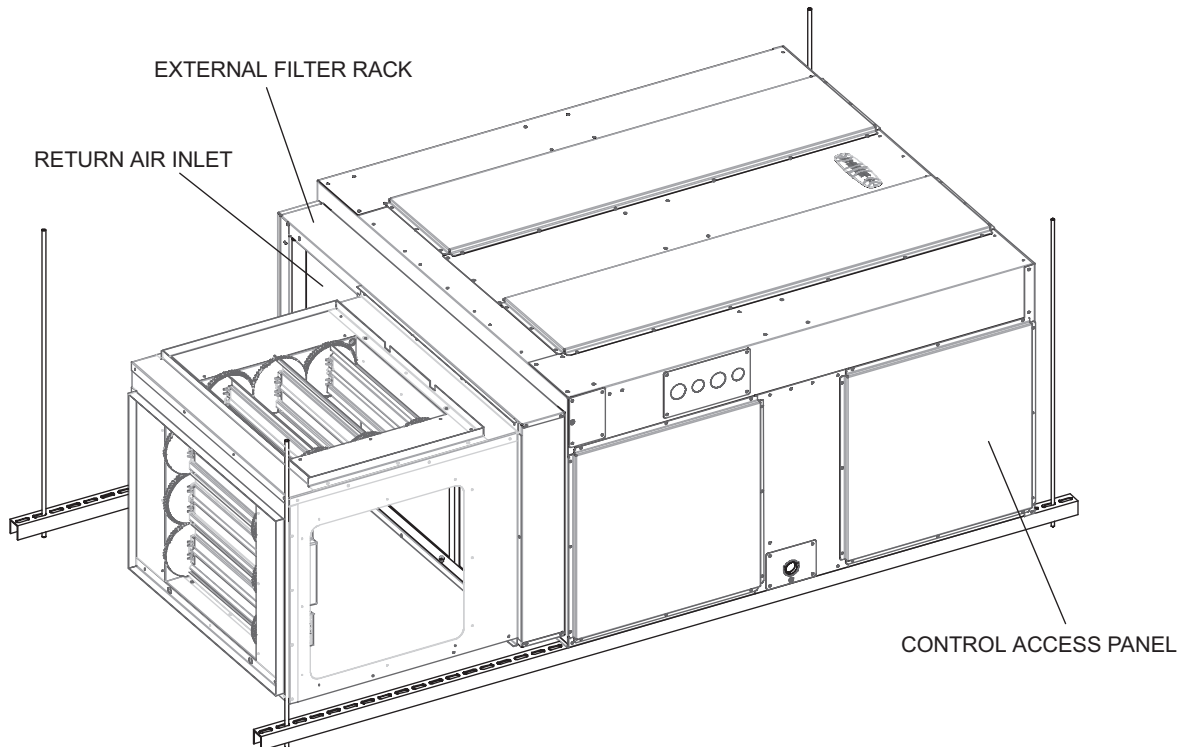

**FIGURE 2. Upflow and Horizontal Applications**

## Economizer Wiring Connections

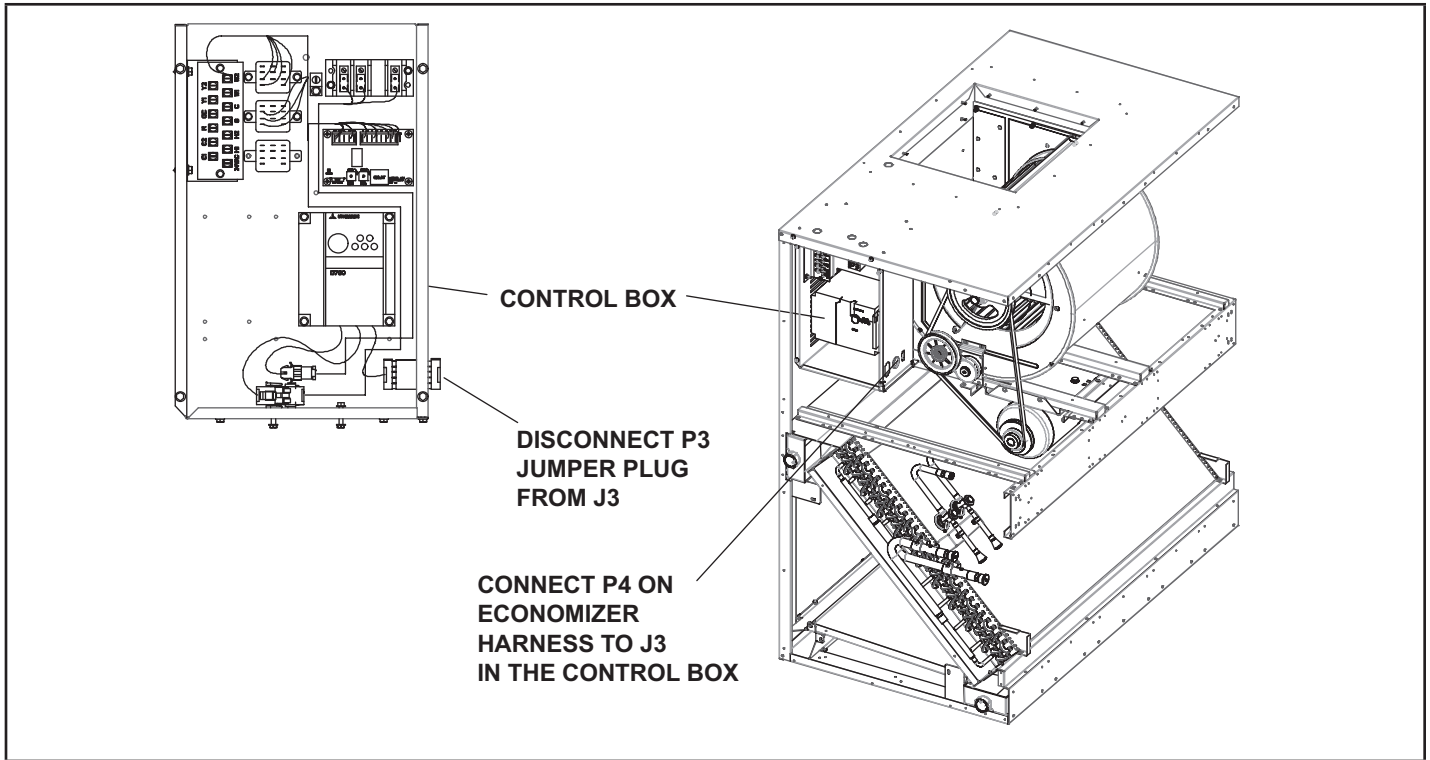

**FIGURE 3. Typical Economizer Wiring**

# High Performance Economizer Sensor Connections

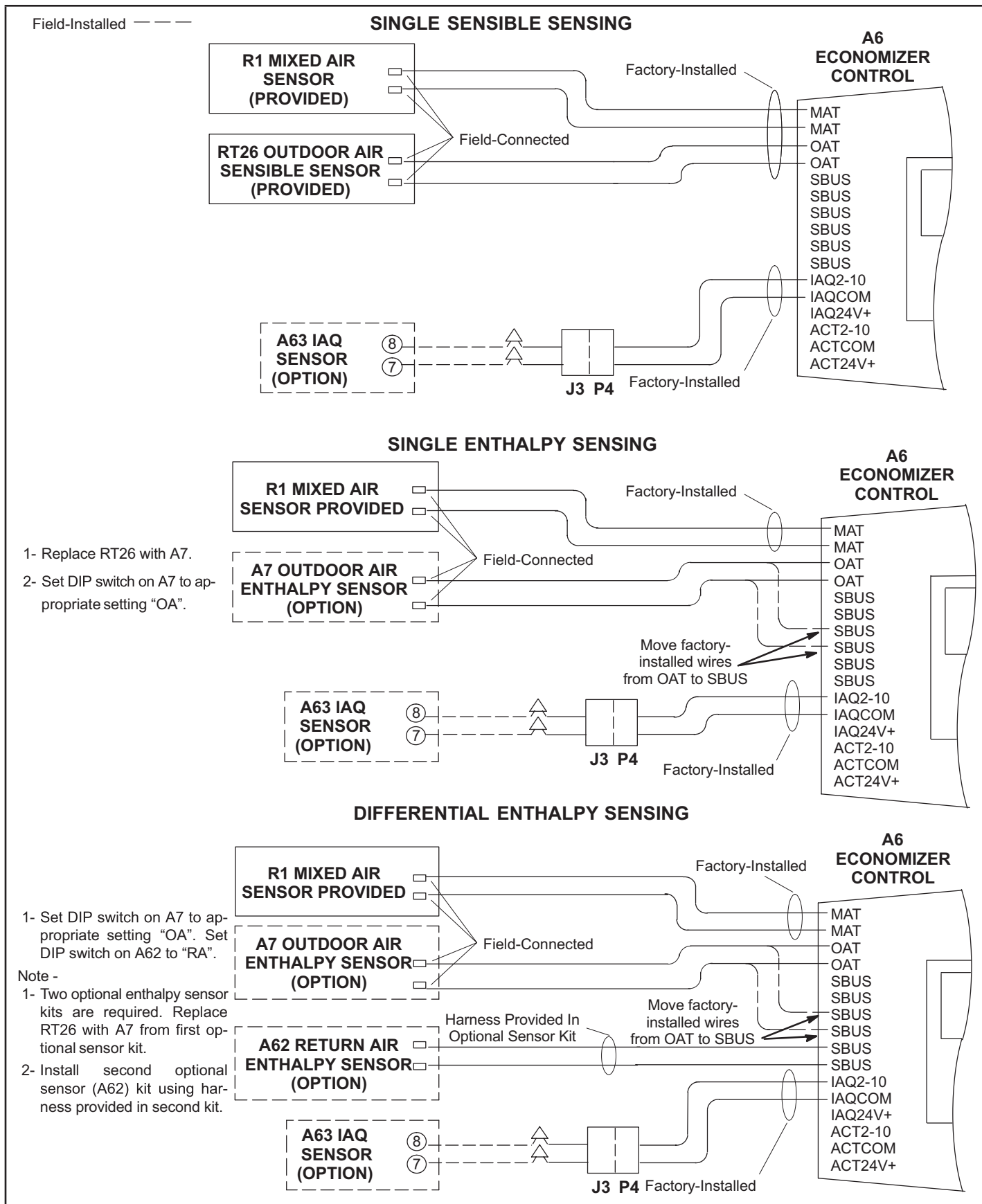
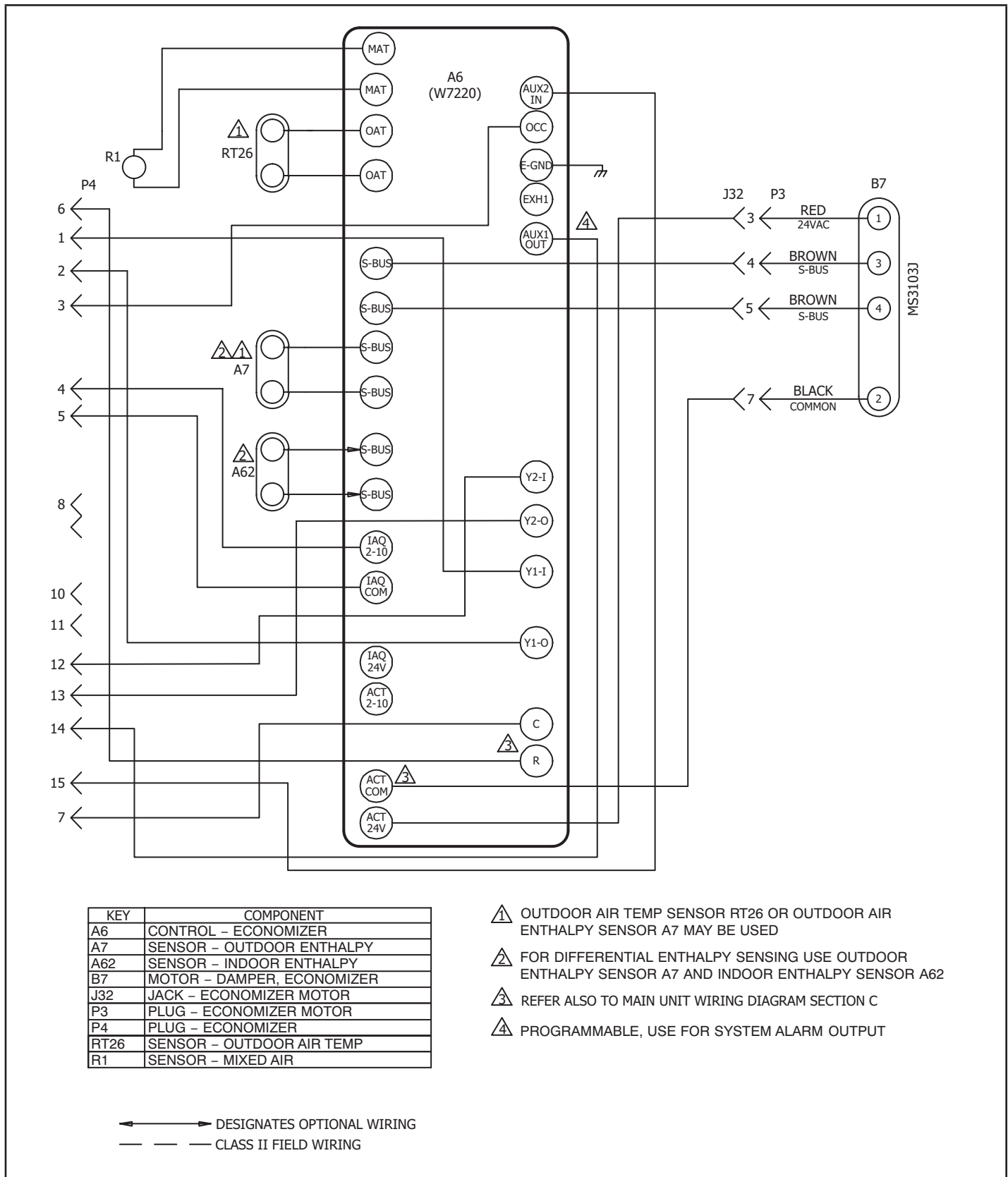

FIGURE 4. High Performance (W7220) Sensor Wiring







**FIGURE 6. Typical Wiring**

## Standard Economizer – A6 Control

### LEDs

A steady green Free Cool LED indicates that outdoor air is suitable for free cooling. A steady green DCV LED indicates that the IAQ reading is higher than setpoint requiring more fresh air. See figure 7.

### FREE COOLING SETPOINT

#### Single Temperature or Enthalpy Sensing:

The economizer control (A6) setpoint may be adjustable. Free cooling will be enabled when outdoor air temperature or enthalpy are lower than the free cooling setpoint. The free cooling setpoints for sensible temperature sensors is 55°F. Table 3 shows the free cooling setpoints for enthalpy sensors. Use the recommended setpoint and adjust as necessary.

For example: At setting A (table 3), free cooling will be enabled when outdoor air enthalpy is lower than 73°F and 50% RH. If indoor air is too warm or humid, lower the setpoint to B. At setting B, free cooling will be enabled at 70°F and 50% RH.

**TABLE 3. Enthalpy Free Cooling Setpoints**

Control Setting	Enthalpy Setpoint At 50% RH
A*	73° F (23° C)
B	70° F (21° C)
C	67° F (19° C)
D	63° F (17° C)

\*Setting A is recommended.

#### Differential Sensing:

Two sensors can be used to compare outdoor air to return air. When outdoor air is cooler than return air, outdoor air is suitable for free cooling. Adjust the free cooling setpoint to D in this application.

When return air is cooler than outdoor air, the damper will modulate to the minimum position.

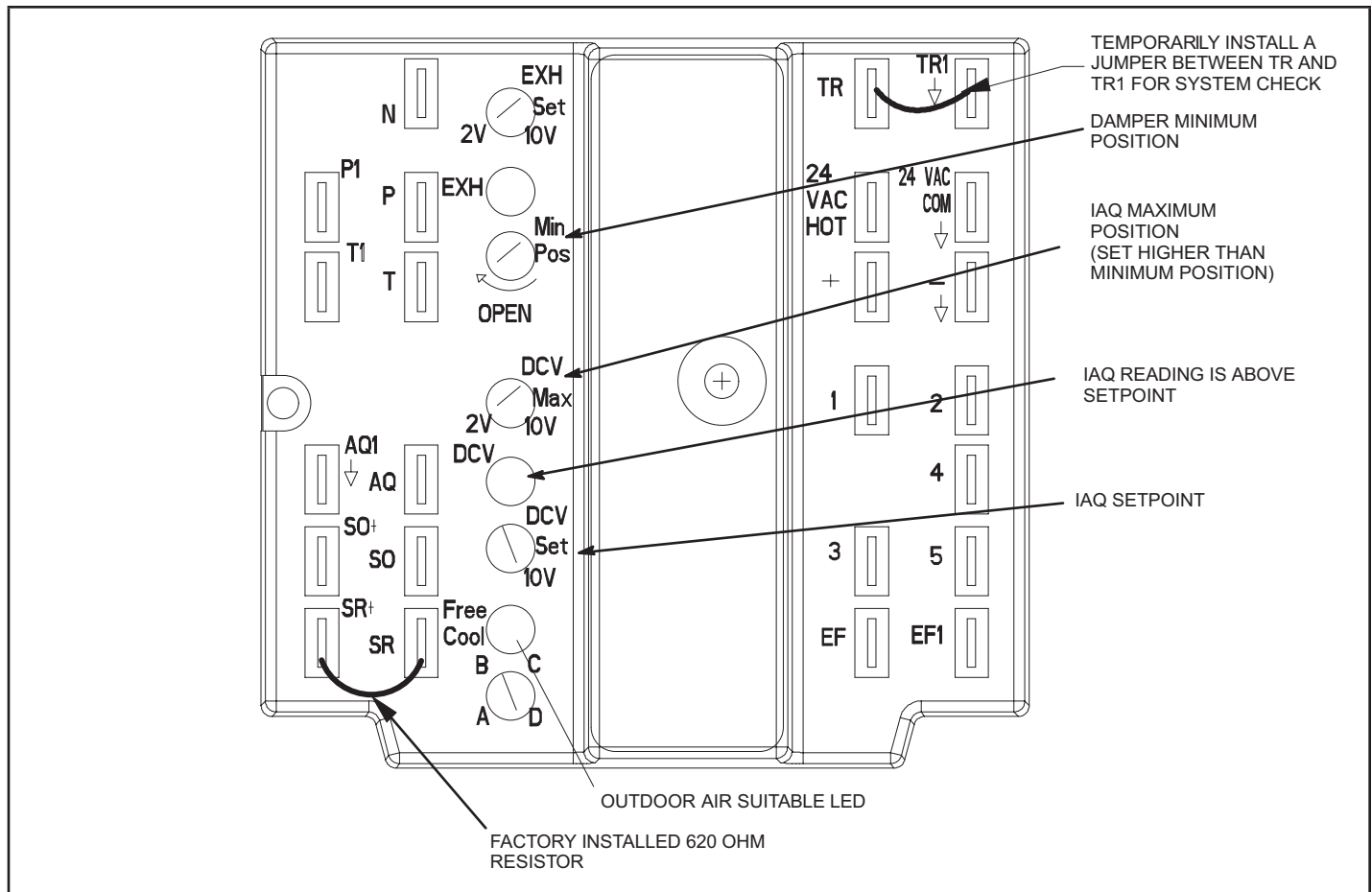

**FIGURE 7. A6 Economizer Control**

## Damper Minimum Position Setting

### SET BLOWER SPEED DURING VENTILATION

To save energy during ventilation, the blower speed can be set to low. This is accomplished by changing the ventilation speed switch on the VFD control board to LO. See figure 8.

The following sections describe how to set the economizer minimum damper positions only. For other information please refer to the economizer instructions included with the economizer.

### STANDARD ECONOMIZER MINIMUM POSITION SETTINGS

**NOTE** – AFTER setting minimum positions, set the “VENT SPEED” switch on the VFD control board to the desired speed. See figure 8.

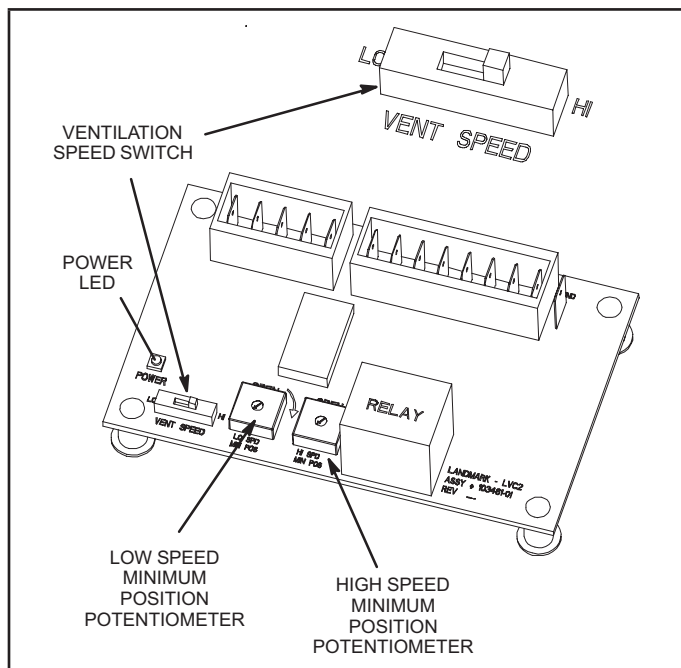

**FIGURE 8. VFD Control Board**

- 1 - Set thermostat to occupied mode if the feature is available. Make sure a jumper is in place between TB1 terminals R and OC when using a thermostat which does not have this feature. See figure 9.

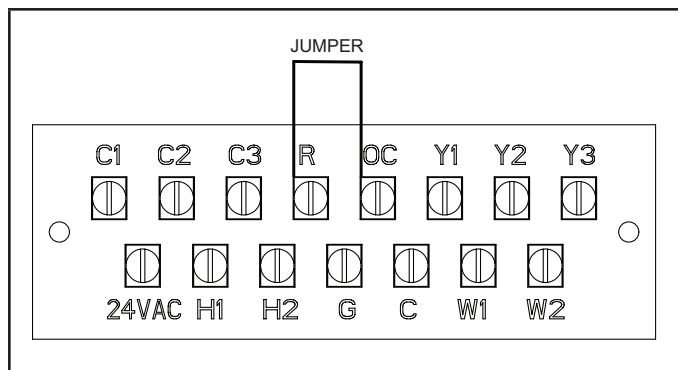
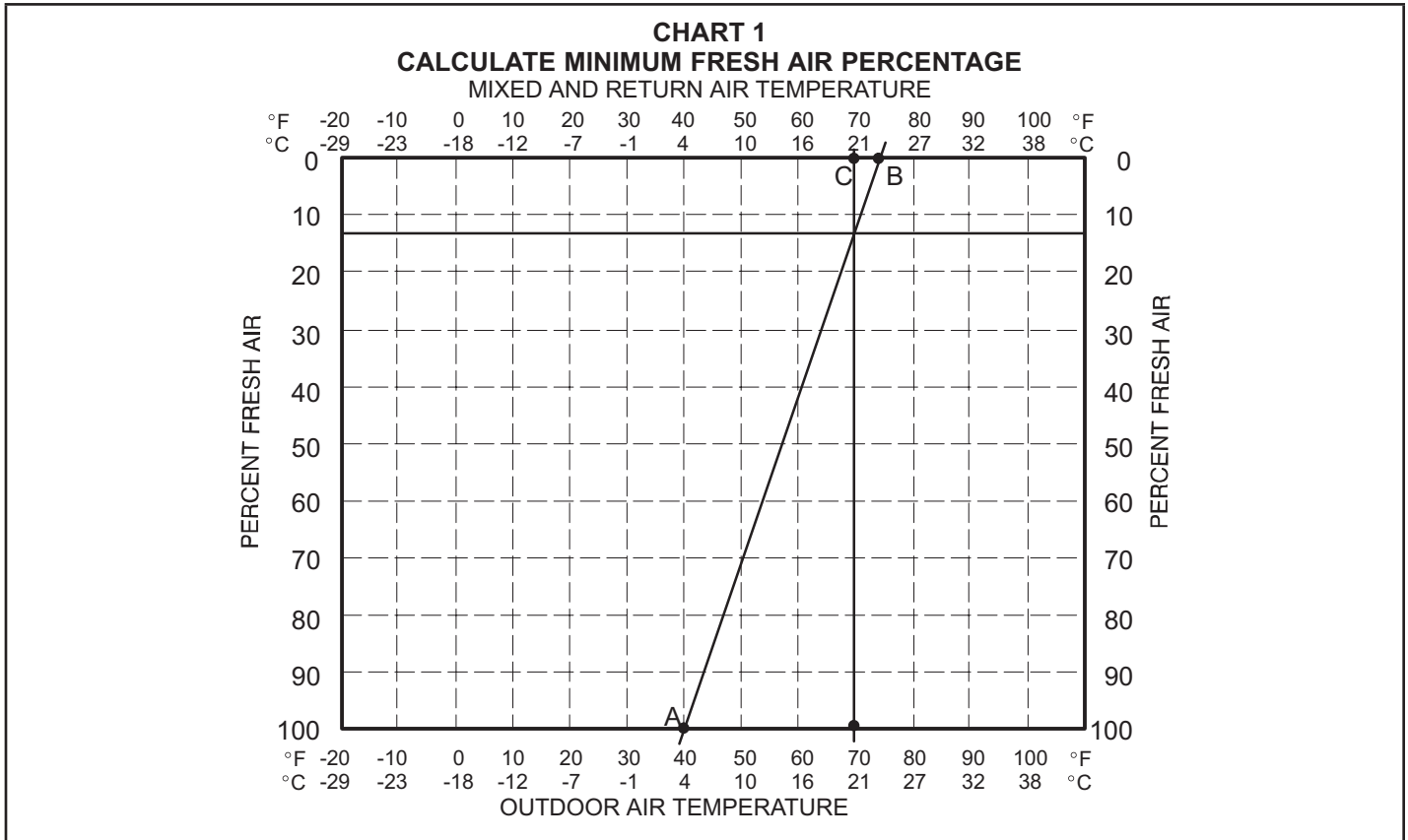

**FIGURE 9. TB1 Terminal R and OC Jumper**

- 2 - Minimum damper position setting - Low Speed. Switch the “Vent Speed” switch on the VFD control board to “LO”.
- 3 - Turn on the indoor blower using the thermostat or by placing a jumper between TB1 terminals R and G. The inverter or variable frequency drive (VFD) should display “40.00Hz”.
- 4 - Adjust the low speed minimum position potentiometer on the VFD control board to the approximate setting. See chart 1.
- 5 - Measure outdoor air temperature. Mark the point on the bottom line of chart 1 and label the point “A” (40°F, 4°C shown).
- 6 - Measure return air temperature. Mark that point on the top line of chart 1 and label the point “B” (74°F, 23°C shown).
- 7 - Measure mixed air (outdoor and return air) temperature. Mark that point on the top line of chart 1 and label point “C” (70°F, 21°C shown).
- 8 - Draw a straight line between points A and B.
- 9 - Draw a vertical line through point C.
- 10 - Draw a horizontal line where the two lines meet. Read the percent of fresh air intake on the side.
- 11 - Repeat steps 4 through 10 until calculation reads desired fresh air percentage. If fresh air percentage is less than desired, adjust MIN POS SET potentiometer clockwise (further open). If fresh air percentage is more than desired, adjust MIN POS SET potentiometer counterclockwise (less open).
- 12 - Minimum damper position setting - High Speed. Switch the “Vent Speed” switch on the VFD control board to “HI”. The VFD should display “60.00HZ”.
- 13 - Adjust the high speed minimum position potentiometer on the VFD control board to the approximate setting. See chart 1.
- 14 - Measure outdoor air temperature. Mark the point on the bottom line of chart 1 and label the point “A” (40°F, 4°C shown).

- 15 - Measure return air temperature. Mark that point on the top line of chart 1 and label the point "B" (74°F, 23°C shown).
- 16 - Measure mixed air (outdoor and return air) temperature. Mark that point on the top line of chart and label point "C" (70°F, 21°C shown). 1
- 17 - Draw a straight line between points A and B.
- 18 - Draw a vertical line through point C.
- 19 - Draw a horizontal line where the two lines meet.

- 20 - Repeat steps 13 through 19 until calculation reads desired fresh air percentage. If fresh air percentage is less than desired, adjust MIN POS SET potentiometer clockwise (further open). If fresh air percentage is more than desired, adjust MIN POS SET potentiometer counterclockwise (less open).
- 21 - AFTER setting both minimum positions, set the "VENT SPEED" switch on the VFD control board to the desired speed. See figure 8.



**HIGH PERFORMANCE ECONOMIZER MINIMUM POSITION SETTINGS**

**NOTE** – AFTER setting minimum positions, set the "VENT SPEED" switch on the VFD control board to "LO". See figure 8. Minimum position potentiometers do not function when the unit is equipped with a W7220 economizer control.

- 1 - Set thermostat to occupied mode if the feature is available. Make sure a jumper is in place between TB1 terminals R and OC when using a thermostat which does not have this feature.
- 2 - Minimum damper position setting - Low Speed  
Switch the blower speed setting on the VFD control board to "LO".
- 3 - Turn on the indoor blower using the thermostat or by placing a jumper between TB1 terminals R and G. The inverter or variable frequency drive (VFD) should display "40.00Hz".
- 4 - Navigate to the "SETPOINTS" menu and select "MIN POS L". Adjust value (2-10VDC) to the

approximate desired fresh air percentage and save the input.

- 3.0 VDC 12% Open Damper
- 3.5 VDC 18% Open Damper
- 4.0 VDC 25% Open Damper
- 4.5 VDC 31% Open Damper
- 5.0 VDC 37% Open Damper
- 5.5 VDC 43% Open Damper
- 6.0 VDC 50% Open Damper

**NOTE** – Damper minimum position can be set lower than traditional minimum air requirements when an IAQ sensor is specified.

- 5 - Navigate to the "CHECKOUT" menu and select "VMAX-LS". Press ←.
- 6 - Display will read "DAMPER VMAX-LS RUN?". Press ←.

## Standard Economizer – Operation

### COOLING MODE

- 1 - On a call for cooling, with ambient temperature and humidity above A6 economizer control set point damper will open to minimum vent position and cooling demand is satisfied by compressor.
- 2 - On a call for cooling, with outside air temperature and humidity (A7) is lower than return air temperature and humidity (A62). the damper will modulate to control supply air temperature at 55°F (13°C). If additional cooling is required, compressor will be energized through second stage of thermostat.

### HEATING MODE

- 1 - On a call for heat during day operation, the damper will open to the minimum vent position.
- 2 - On a call for heat during night operation (requires optional field-provided night thermostat with clock), the damper will remain closed.

## High Performance Economizer – A6 Control

**NOTE** – The A6 economizer control will be in the “setup” mode for the first sixty minutes after powered. If a sensor for outdoor air or SBUS device (sensor, actuator) is disconnected during the set up mode, the A6 will not alarm that failure. The R1 mixed air sensor is a system “critical” sensor; if the mixed air sensor is removed during the set up mode, the A6 will alarm. After sixty minutes the A6 will change to operation mode and all components removed or failed will alarm in the operation mode.

### INITIAL SETUP

A default program must be modified for proper operation in each application. This is done during the initial setup procedure. See *Setup and Configuration*.

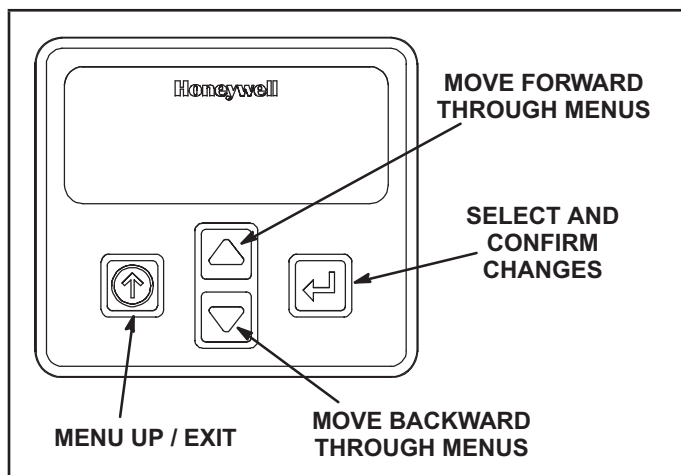

**FIGURE 10. A6 Economizer Control Keypad USING THE KEYPAD**

Use the keypad as follows:

- Navigate to the desired menu.
- Press the button (enter) to display the first item in the currently displayed menu.

- Use the and buttons to scroll to the desired parameter.
- Press the enter button (enter) to display the value of the currently displayed item.
- Press the button to increase (change) the displayed parameter value.<sup>a</sup>
- Press the button to decrease (change) the displayed parameter value.<sup>a</sup>
- Press the enter button (enter) to accept the displayed value and store it in non-volatile RAM.
- CHANGE STORED displays.
- Press the button (enter) to return to the current menu parameter.
- Press the button (MenuUp/Exit) to return to the previous menu.

When values are displayed, pressing and holding the or button causes the display to automatically increment.

### MENU STRUCTURE

The menus in display order are:

- STATUS
- SETPOINTS
- SYSTEM SETUP
- ADVANCED SETUP
- CHECKOUT
- ALARMS

For a complete list of parameters refer to the Honeywell installation manual provided in this kit.

**IMPORTANT** – Menu parameters will be different depending on each configuration. For example: if a DCV (CO<sub>2</sub>) sensor is not used, none of the DCV parameters will appear and only MIN POS will display. If a CO<sub>2</sub> sensor is used, the DCV SET, VENTMIN and VENTMAX will appear.

### SETUP AND CONFIGURATION

Program the following parameters into the controller.

Navigate to the specific menus to make the changes required.

**IMPORTANT** – During setup, the economizer control is live at all times.

The setup process uses a hierarchical menu structure.

Press the and arrow buttons to move forward and backward through the menus and press the button to select and confirm setup item changes.

1 - In the **SYSTEM SETUP** Menu

- INSTALL (MM/DD/YY) enter installation date
- EQUIPMENT (CONV)
- AUX2 IN (HEAT W1)
- FAN SPEED (1SPEED CAV unit)  
(2SPEED MSAV unit)
- FAN CFM ( ) enter highest indoor blower capacity of rooftop unit.
- AUX1 OUT (NONE) change to SYS if A6 controller is wired for remote alarm monitoring.
- OCC (INPUT)

2 - In the **ADVANCED SETUP** Menu

- MA LO SET (45°F)
- FREEZE POS (CLOSE)
- STG3 DLY (2HRS)
- SD DMPR POS (CLOSED)

3 - In the **SETPOINTS** Menu

- MA SET (55°F)
- LO T LOCK (32°F)
- MIN POS ( VDC) refer to minimum position setting section for details.

### ALARM MONITORING

The controller is equipped with a 24V output signal that can be configured for remote alarm monitoring.

In the "SYSTEM SETUP" menu change the "AUX1 OUT" setting to "SYS". Refer to figure 11 for wiring connections provided.

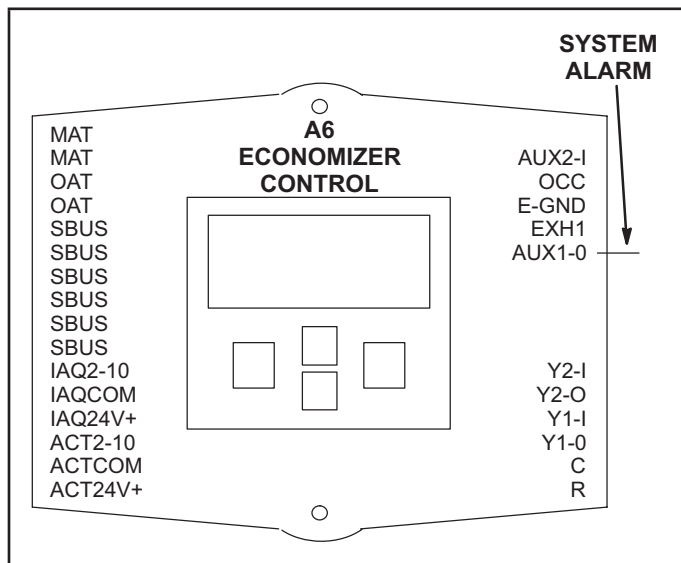

FIGURE 11. A6 Control High Performance Terminals

## High Performance Economizer – Settings

### Single OA Sensible Sensing (Default)

The default free cooling setpoint or high limit setpoint is 63°F. This means that the outdoor air is suitable for free cooling at 62°F and below and not suitable at 64°F and above. This setpoint is adjustable.

For *California Title 24* compliance, adjust the free cooling setpoint based on:

- The climate zone where the unit is installed. See table 4.
- The setpoint requirement published by the California Energy Commission. See Section 140.4 - Prescriptive Requirements for Space Conditioning Systems of the 2013 Building Energy Efficiency Standards.

**NOTE** – Values in the referenced standard will supersede values listed in table 4.

TABLE 4. Free Cooling Setpoint – Single Sensible

Climate Zone	Setpoint
1, 3, 5, 11-16	75°F
2, 4, 10	73°F
6, 8, 9	71°F
7	69°F

To adjust the setpoint, navigate to the "SETPOINTS" menu and change the "DRYBLB SET" parameter accordingly.

### Single OA Enthalpy Sensing (Optional)

The controller uses enthalpy boundary "curves" for economizing when used with an enthalpy sensor. Refer to the Honeywell installation instruction for details.

### Differential Sensing (Optional)

Two sensors can be used to compare outdoor air to return air. When outdoor air is cooler than return air, outdoor air is suitable for free cooling. When return air is cooler than outdoor air, the damper will modulate to the minimum position.

### DAMPER MINIMUM POSITION

**NOTE** – 24 volts must be provided at unit TB1 terminals **R** and **OC** to enable economizer operation (allowing minimum fresh air). Typically a separately ordered thermostat or energy management system with an occupied/unoccupied output is connected between TB1 **R** and **OC** terminals. The thermostat will provide 24 volts to the A6 economizer control during the occupied time period to enable economizer minimum position. If a device is not used to enable the economizer, install a jumper wire between TB1 terminals **R** and **OC** to maintain minimum position continuously. See figure 12.

Make wire connections to TB1 terminals **R** and **OC** as shown in literature provided with thermostat or energy management system.

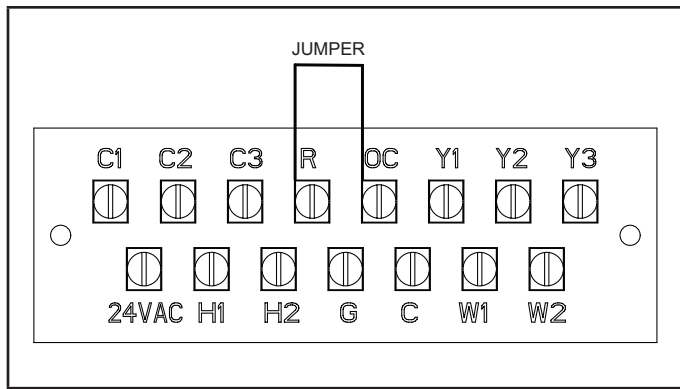

**FIGURE 12. TB1 Terminal R and OC Jumper**

**UNITS WITH 2-SPEED SUPPLY AIR BLOWER**

**NOTE** – AFTER setting minimum positions, set the “VENT SPEED” switch on the VFD control board to “LO”. Minimum position potentiometers do not function when the unit is equipped with a W7220 economizer control.

- 1 - Set thermostat to occupied mode if the feature is available. Make sure a jumper is in place between TB1 terminals R and OC when using a thermostat which does not have this feature.
- 2 - **Minimum damper position setting – Low Speed**  
**Switch the blower speed setting on the VFD control board to “LO”.**
- 3 - Turn on the indoor blower using the thermostat or by placing a jumper between TB1 terminals R and G. The inverter or variable frequency drive (VFD) should display “40.00Hz”.
- 4 - Navigate to the “SETPOINTS” menu and select “MIN POS L”. Adjust value (2-10VDC) to the approximate desired fresh air percentage and save the input.
  - 3.0 VDC – 12% Open Damper
  - 3.5 VDC – 18% Open Damper
  - 4.0 VDC – 25% Open Damper
  - 4.5 VDC – 31% Open Damper
  - 5.0 VDC – 37% Open Damper
  - 5.5 VDC – 43% Open Damper
  - 6.0 VDC – 50% Open Damper

**NOTE** – Damper minimum position can be set lower than traditional minimum air requirements when an IAQ sensor is specified.

- 5 - Navigate to the “CHECKOUT” menu and select “VMAX-LS”. Press ←.
- 6 - Display will read “DAMPER VMAX-LS RUN?”. Press ←.
- 7 - Damper will drive to the setpoint value stored in step 4.
- 8 - Measure outdoor air temperature. Mark the point on the bottom line of chart 1 and label the point “A” (40°F, 4°C shown).

- 9 - Measure return air temperature. Mark that point on the top line of chart 1 and label the point “B” (74°F, 23°C shown).
- 10 - Measure mixed air (outdoor and return air) temperature. Mark that point on the top line of chart 1 and label point “C” (70°F, 21°C shown).
- 11 - Draw a straight line between points A and B.
- 12 - Draw a vertical line through point C.
- 13 - Draw a horizontal line where the two lines meet. Read the percent of fresh air intake on the side.
- 14 - Repeat steps 4 through 13 until calculation reads desired fresh air percentage.

*If fresh air percentage is less than desired, use the A6 keypad to adjust “MIN POS L” values higher (further open). If fresh air percentage is more than desired, adjust “MIN POS L” values lower (less open).*

- 15 - **Minimum damper position setting - High Speed**  
**Switch the blower speed setting on the VFD control board to “HI”.** The VFD should display “60.00HZ”.
- 16 - Navigate to the “SETPOINTS” menu and select “MIN POS H”. Adjust value (2-10VDC) to the approximate desired fresh air percentage.
  - 3.0 VDC – 12% Open Damper
  - 3.5 VDC – 18% Open Damper
  - 4.0 VDC – 25% Open Damper
  - 4.5 VDC – 31% Open Damper
  - 5.0 VDC – 37% Open Damper
  - 5.5 VDC – 43% Open Damper
  - 6.0 VDC – 50% Open Damper

**NOTE** – Damper minimum position can be set lower than traditional minimum air requirements when an IAQ sensor is specified.

- 17 - Navigate to the “CHECKOUT” menu and select “VMAX-HS”. Press ←.
- 18 - Display will read “DAMPER VMAX-HS RUN?”. Press ←.
- 19 - Damper will drive to the setpoint value stored in step 16.
- 20 - Measure outdoor air temperature. Mark the point on the bottom line of chart 1 and label the point “A” (40°F, 4°C shown).
- 21 - Measure return air temperature. Mark that point on the top line of chart 1 and label the point “B” (74°F, 23°C shown).
- 22 - Measure mixed air (outdoor and return air) temperature. Mark that point on the top line of chart 1 and label point “C” (70°F, 21°C shown).
- 23 - Draw a straight line between points A and B.
- 24 - Draw a vertical line through point C.
- 25 - Draw a horizontal line where the two lines meet. Read the percent of fresh air intake on the side.



26 - Repeat steps 16 through 25 until calculation reads desired fresh air percentage.

If fresh air percentage is less than desired, use the A6 keypad to adjust “MIN POS H” values higher (further open). If fresh air percentage is more than desired, adjust “MIN POS H” values lower (less open).

27 - Set the “VENT SPEED” switch on the VFD control board to “LO”.

**DEMAND CONTROL VENTILATION (DCV)**

When a 210VDC CO<sub>2</sub> sensor is wired to the controller (leads provided), the DCV SET, VENTMIN, and VENTMAX parameters will appear under “SETPOINTS” menu. Navigate to the “SETPOINTS” menu to adjust setpoints as desired. Refer to the Honeywell manual provided for more details.

**High Performance Economizer – Sequence of Operation**

Refer to tables 5 or 6.

When the outdoor air is suitable and a thermostat demand calls for 1st. stage cooling (Y1), the economizer will modulate the dampers between the minimum and fully open positions to maintain a 55F (12.8C) mixed air temperature. When there is an increased thermostat demand for second stage cooling (Y2), the economizer damper opens 100% and the economizer controller (A6) will bring on the compressor. The damper will stay open 100% with the compressor running simultaneously until Y2 demand is met.

**NOTE** – When there is a Y1 cooling demand, the economizer controller (A6) will display the mixed air temperature (R1). When there is a Y2 cooling demand and compressors are operating, the economizer controller (A6) will display the outdoor air temperature (RT26 or A7). In either case, the economizer controller (A6) will use the mixed air sensor for low temperature lock-out.

**TROUBLESHOOTING, ALARMS AND CHECKOUT TESTS**

Refer to the Honeywell manual provided for details.

**TABLE 5. Economizer Operation – No DVC (CO<sub>2</sub> Sensor, 2-Speed Supply Fan)**

DVC	OA Good to Economize?	Y1-I	Y2-I	Fan Speed	Y1-O	Y2-O	Occupied	Unoccupied
None	No	Off	Off	Low	0-v/Off	0-v/Off	MIN POS L	Closed
		On	Off	Low	24-v/On	0-v/Off	MIN POS L	Closed
		On	On	High	24-v/On	24-v/On	MIN POS H	Closed
None	Yes	Off	Off	Low	0-v/Off	0-/Off	MIN POS L	Closed
		On	Off	High	0-v/Off	0-v/Off	MIN POS L to Full-Open	Closed to Full-Open
		On	On	High	Delay (b) 24-v/On	0-v/Off	Full-Open	Full-Open

(b) With 2SP FAN DELAY (Advance Setup Menu), when in the economizing mode, there is a delay for the high speed fan to try to satisfy the call for second-stage cooling by turning on the fan to high and opening the OA dampers to 100% before the first-stage mechanical cooling is enabled.

**TABLE 6. Economizer Operation – With DCV ( CO2 Sensor, 2-Speed Supply Fan)**

DVC	OA Good to Economize?	Y1-I	Y2-I	Fan Speed	Y1-O	Y2-O	Occupied	Unoccupied
Below set	No	Off	Off	Low	0-v/Off	0-v/Off	VENTMIN L	Closed
		On	Off	Low	24-v/On	0-v/Off	VENTMIN L	Closed
		On	On	High	24-v/On	24-v/On	VENTMIN H	Closed
	Yes	Off	Off	Low	0-v/Off	0-v/Off	VENTMIN L	Closed
		On	Off	High	0-v/Off	0-v/Off	VENTMIN L to Full-Open	Closed to Full-Open
		On	On	High	Delay (b) 24-v/On	0-v/Off	Full-Open	Full-Open
Above set	No	Off	Off	Low	0-v/Off	0-v/Off	VENTMIN L to VENTMAX L	Closed
		On	Off	Low	24-v/On	0-v/Off	VENTMIN L to VENTMAX L	Closed
		On	On	High	24-v/On	24-v/On	VENTMIN L to VENTMAX H	Closed
	Yes	Off	Off	Low	0-v/Off	0-v/Off	VENTMIN L to VENTMAX L	Closed
		On	Off	High	0-v/Off	0-v/Off	VENTMIN L to Full-Open	Closed to Full-Open
		On	On	High	Delay (b) 24-v/On	0-v/Off	Full-Open	Full-Open

(b) With 2SP FAN DELAY (Advance Setup Menu), when in the economizing mode, there is a delay for the high speed fan to try to satisfy the call for second-stage cooling by turning on the fan to high and opening the OA dampers to 100% before the first-stage mechanical cooling is enabled.

**Maintenance**

- 1 - Damper motor is prelubricated and does not require further lubrication.
- 2 - Make visual inspection of dampers and linkage assemblies during routine maintenance.