

INSTALLATION INSTRUCTIONS

Table of Contents

Dimensions in. (mm).....	2
Parts Arrangement	2
Shipping and Packing List	3
General.....	3
Requirements	3
Unit Support.....	4
Duct Connection	4
Rigging Unit For Lifting	5
Unpacking.....	5
Downflow Air Discharge.....	5
Horizontal Air Discharge	6
Condensate Drains.....	6
Connect Gas Piping.....	7
Pressure Test Gas Piping	7
Install Vent Hood	8
High Altitude Derate.....	8
Electrical Connections.....	8
Blower Operation and Adjustments	9
Cooling Start-Up.....	15
Gas Heat Start-Up	16
Heating Operation and Adjustments.....	18
Service.....	19
Equipment Checks	24

QGA036	3-Ton
QGA042	3-1/2-Ton
QGA048	4-Ton
QGA060	5-Ton

GAS AND COOLING PACKAGED UNITS
508073-01
12/2022

⚠ WARNING
Improper installation, adjustment, alteration, service or maintenance can cause property damage, personal injury or loss of life. Installation and service must be performed by a licensed professional HVAC installer or equivalent, service agency, or the gas supplier.

⚠ CAUTION
As with any mechanical equipment, contact with sharp sheet metal edges can result in personal injury. Take care while handling this equipment and wear gloves and protective clothing.

RETAIN THESE INSTRUCTIONS FOR FUTURE REFERENCE

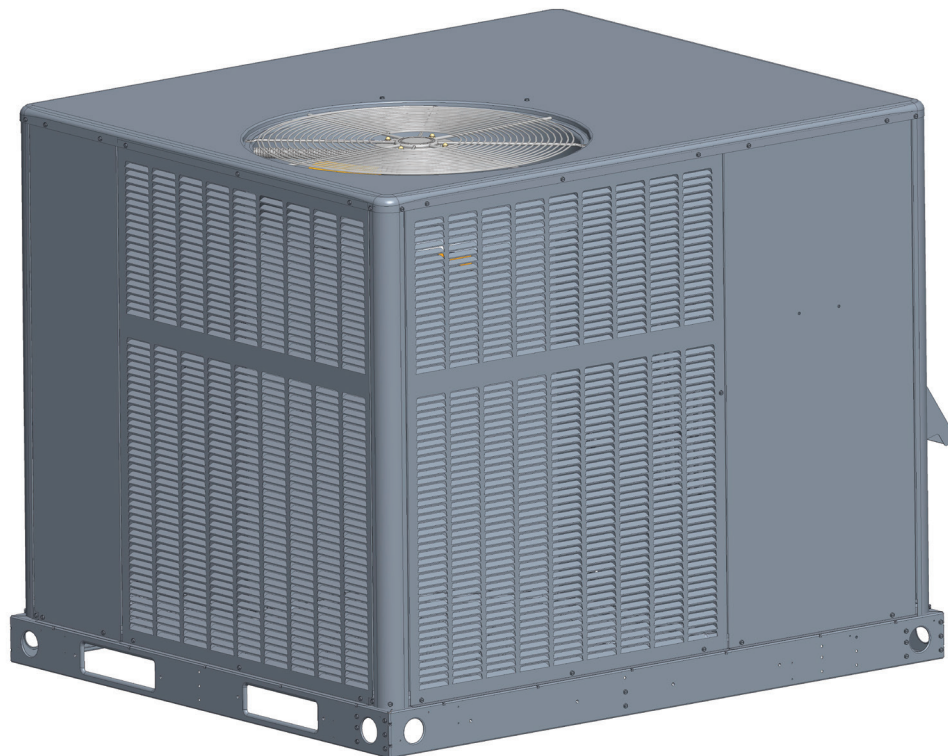

Dimensions in. (mm)

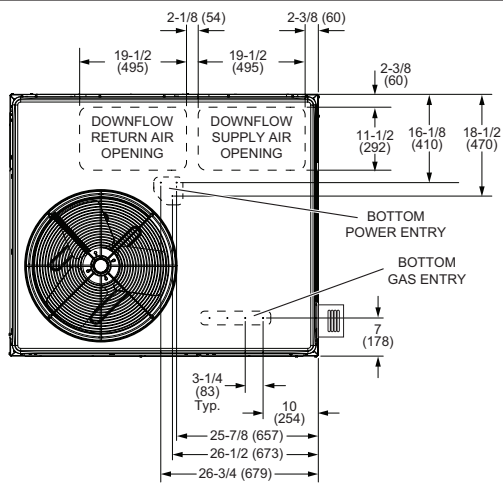

TOP VIEW (Base)

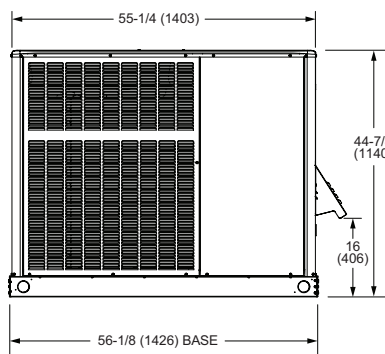

FRONT VIEW

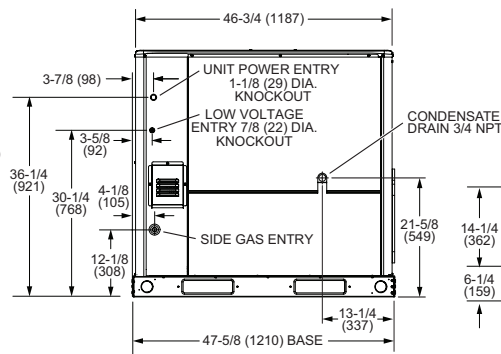

RIGHT SIDE VIEW

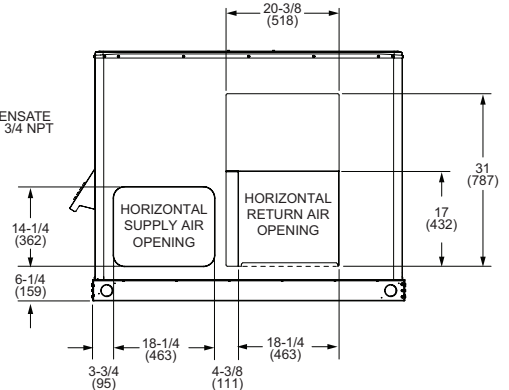

BACK VIEW

Parts Arrangement

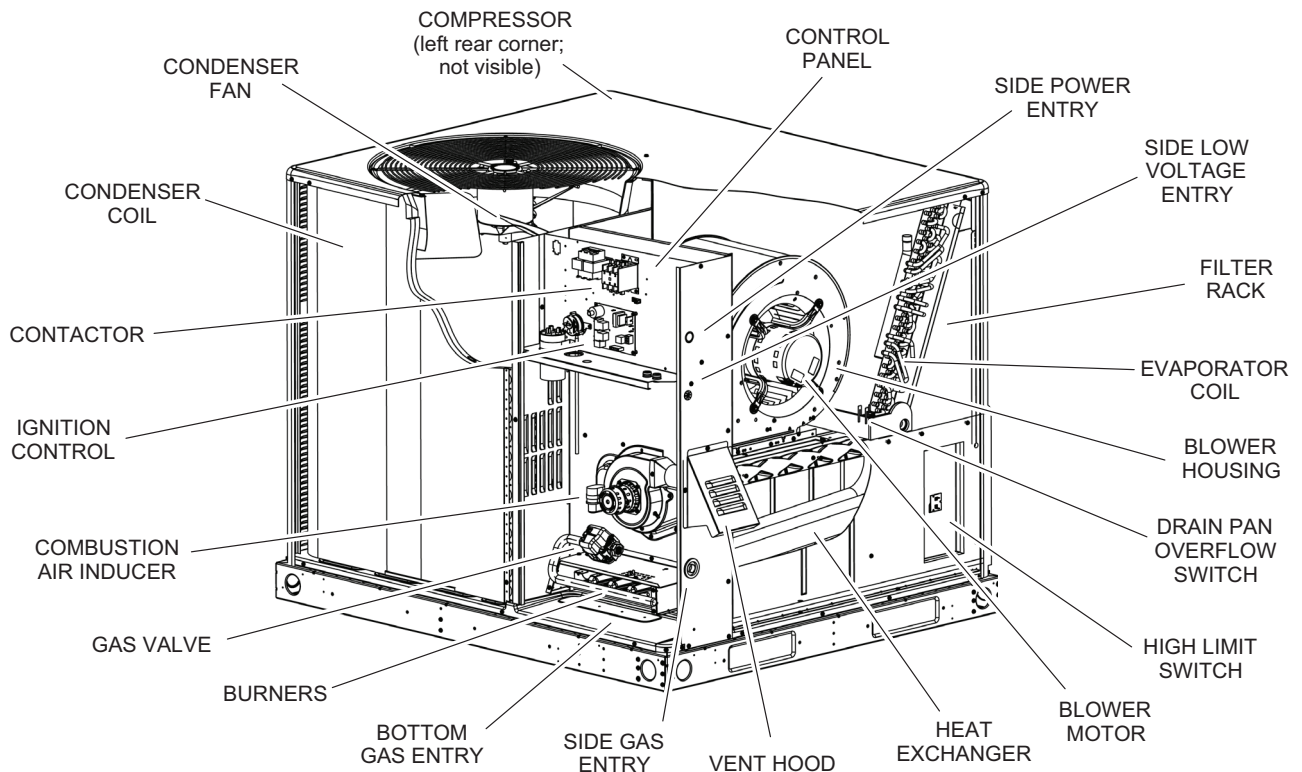

Shipping and Packing List

Package 1 of 1 contains:

1 - Assembled unit

Check unit for shipping damage. Receiving party should contact last carrier immediately if shipping damage is found.

General

These instructions are intended as a general guide and do not supersede local codes in any way. Authorities having jurisdiction should be consulted before installation.

The QGA units are gas/electric packaged units available in four cooling capacities and five gas heating inputs.

Requirements

See FIGURE 1 for unit clearances.

⚠ NOTICE

Roof Damage!

This system contains both refrigerant and oil. Some rubber roofing material may absorb oil, causing the rubber to swell. Bubbles in the rubber roofing material can cause leaks. Protect the roof surface to avoid exposure to refrigerant and oil during service and installation. Failure to follow this notice could result in damage to roof surface.

⚠ WARNING



Electric shock hazard and danger of explosion. Can cause injury, death or product or property damage. Turn off gas and electrical power to unit before performing any maintenance or servicing operations on the unit. Follow lighting instructions attached to unit when putting unit back into operation and after service or maintenance.

⚠ IMPORTANT

The Clean Air Act of 1990 bans the intentional venting of refrigerant (CFC's and HCFC's) as of July 1, 1992. Approved methods of recovery, recycling or reclaiming must be followed. Fines and/or incarceration may be levied for non-compliance.

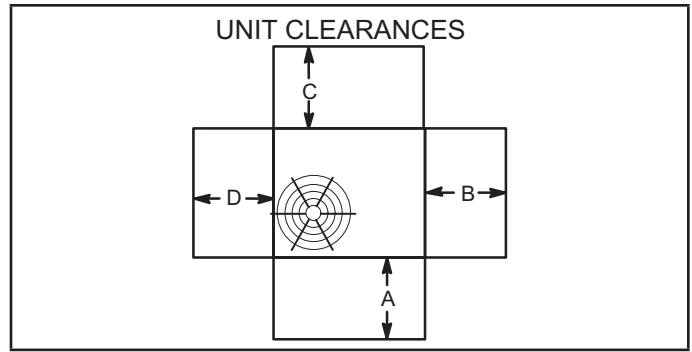

FIGURE 1

¹ Unit Clearance	A in.	B in.	C in.	D in.	Top Clearance
Service Clearance	24	24	0	24	48
Clearance to Combustibles	0	12	0	0	0

*Clearance to combustibles below the unit flue is 10 inches since the flue points down.

NOTE - Entire perimeter of unit base requires support when elevated above mounting surface.

¹ **Service Clearance** - Required for removal of serviceable parts.

Clearance to Combustibles - Required clearance to combustible material (gas units).

Minimum Operation Clearance - Required clearance for proper unit operation. Location

- 1 - Unit is designed for outdoor installation only. Unit must be installed so all electrical components are protected from water.
- 2 - Condenser coils must have an unlimited supply of air.
- 3 - For ground level installation, use a level prefabricated pad or use a level concrete slab. Do not tie the slab to the building foundation.
- 4 - Maintain level within a tolerance of 1/4" maximum across the entire length or width of the unit.

⚠ CAUTION

Unit levelness is critical for proper float switch operation.

Use of this unit as a construction heater or air conditioner is not recommended during any phase of construction. Very low return air temperatures, harmful vapors and operation of the unit with clogged or misplaced filters will damage the unit.

If this unit has been used for heating or cooling of buildings or structures under construction, the following conditions must be met or the warranty will be void:

- A room thermostat must control the unit. The use of fixed jumpers that will provide continuous heating or cooling is not allowed.
- A pre-filter must be installed at the entry to the return air duct.
- The return air duct must be provided and sealed to the unit.

- Return air temperature range between 55°F (13°C) and 80°F (27°C) must be maintained.
- Air filters must be replaced and pre-filters must be removed upon construction completion.
- The input rate and temperature rise must be set per the unit rating plate.
- The heat exchanger, components, duct system, air filters and evaporator coil must be thoroughly cleaned following final construction clean-up.
- The unit operating conditions (including airflow, cooling operation, ignition, input rate, temperature rise and venting) must be verified according to these installation instructions.

Unit Support

In the U.S., units may be installed on combustible floors made from wood or class A, B, or C roof covering material.

In Canada, units may be installed on combustible floors.

NOTE - Securely fasten roof curb to roof per local codes.

CAUTION

To reduce the likelihood of supply / return air bypass and promote a proper seal with the rooftop unit, duct work / duct drops / diffuser assemblies must be supported independently to the building structure.

A - Downflow Discharge Application

Roof Mounting with ACURB85

- 1 - The ACURB85 roof mounting curb must be installed, flashed and sealed in accordance with the instructions provided with the curb.
- 2 - The ACURB85 roof mounting curb should be square and level to 1/16" per linear foot (5mm per linear meter) in any direction.
- 3 - Duct must be attached to the roof mounting curb and not to the unit; supply and return plenums must be installed before setting the unit.
- 4 - Prior to setting the unit on the roof curb, remove the shipping bracket located underneath the unit. Remove the two screws in the base rail (located on the front and rear of the unit). The four screws and the bracket can be discarded. See FIGURE 2.
- 5 - Be sure that all required clearances are observed (see Clearances section).

Installer's Roof Mounting Curb

Many types of roof curbs can be used to install the unit depending upon different roof structures. Items to keep in mind when using the building curb or supports are:

- 1 - The base is fully enclosed and not insulated, so an enclosed, insulated curb is required.
- 2 - The curbs or supports must be constructed with non-combustible materials and should be square and level to 1/16" per linear foot (5mm per linear meter) in any direction.
- 3 - Curb or supports must be high enough to prevent any form of moisture from entering unit. Recommended minimum curb height is 14" (356mm).
- 4 - Duct must be attached to the roof mounting curb and not to the unit. Supply and return plenums must be installed before setting the unit.
- 5 - Units require support along all four sides of unit base. Supports must be constructed of steel or suitably treated wood materials.

B - Horizontal Discharge Applications

- 1 - Specified installation clearances must be maintained when installing units. Refer to FIGURE 1.
- 2 - Top of support slab should be approximately 4" (102mm) above the finished grade and located so no run-off water from higher ground can collect around the unit.
- 3 - Units require support along all four sides of unit base. Supports must be constructed of steel or suitably treated wood materials.

Duct Connection

All exterior ducts, joints and openings in roof or building walls must be insulated and weather-proofed with flashing and sealing compounds in accordance with applicable codes. Any duct passing through an unconditioned space must be insulated.

The duct system should be designed and sized according to the methods in the Air Conditioning Contractors of America (ACCA) manual that is most appropriate to the installation application.

A closed return air duct system shall be used. This shall not preclude use of economizers or outdoor fresh air intake.

It is recommended that supply and return air duct connections at the unit be made with flexible joints. The supply and return air duct systems should be designed for the CFM and static requirements of the job. They should not be sized by matching the dimensions of the duct connections on the unit. The unit is shipped capable of either horizontal flow (side duct connections) or down flow (bottom duct connections). Duct attachment screws are intended to go into the duct panel. Duct to unit connections must be sealed and weather-proofed.

CAUTION

In downflow applications, do not drill or punch holes in base of unit. Leaking in roof may occur if unit base is punctured.

Rigging Unit For Lifting

Rig unit for lifting by attaching four cables to holes in unit base rail. See FIGURE 2.

Exercise care when moving the unit. Do not remove any packaging until the unit is near the place of installation.

- 1 - Connect rigging to the unit base rails using both holes in each corner.
- 2 - All panels must be in place for rigging.
- 3 - Place field-provided spreaders in place. Spreaders must be of adequate strength and length (must exceed unit dimension by 6 inches). Units may also be moved or lifted with a forklift. **The lengths of the forks of the forklift must be a minimum of 42 inches.**

CAUTION - Before lifting a unit, make sure that the weight is distributed equally on the cables so that it will lift evenly.

Unpacking

Locate the four stacking brackets at each corner of the top panel. Remove the screws that secure these brackets. All screws must be re-installed. The stacking brackets can be discarded. Remove the bag and remaining packaging material, which can be discarded. Locate the four plastic fork slot bumpers on the base rails. Remove the fasteners and bumpers and discard.

Downflow Air Discharge

Unit is shipped with panels covering the horizontal and downflow supply and return air openings (four covers).

- 1 - Before setting the unit on a roof curb, see "Roof Mounting" section for instructions on removing the shipping bracket underneath the unit.
- 2 - Remove and retain the horizontal supply and return duct covers.
- 3 - Remove the four screws securing the downflow duct covers inside the unit. Remove and discard the covers.
- 4 - Remove screws located between the supply and return air openings that attach the blower deck to the base, and discard these screws. These screws can interfere with bottom duct connections or roof curb seals.
- 5 - Install the duct system onto the unit.
- 6 - Replace the retained horizontal supply and return duct covers.

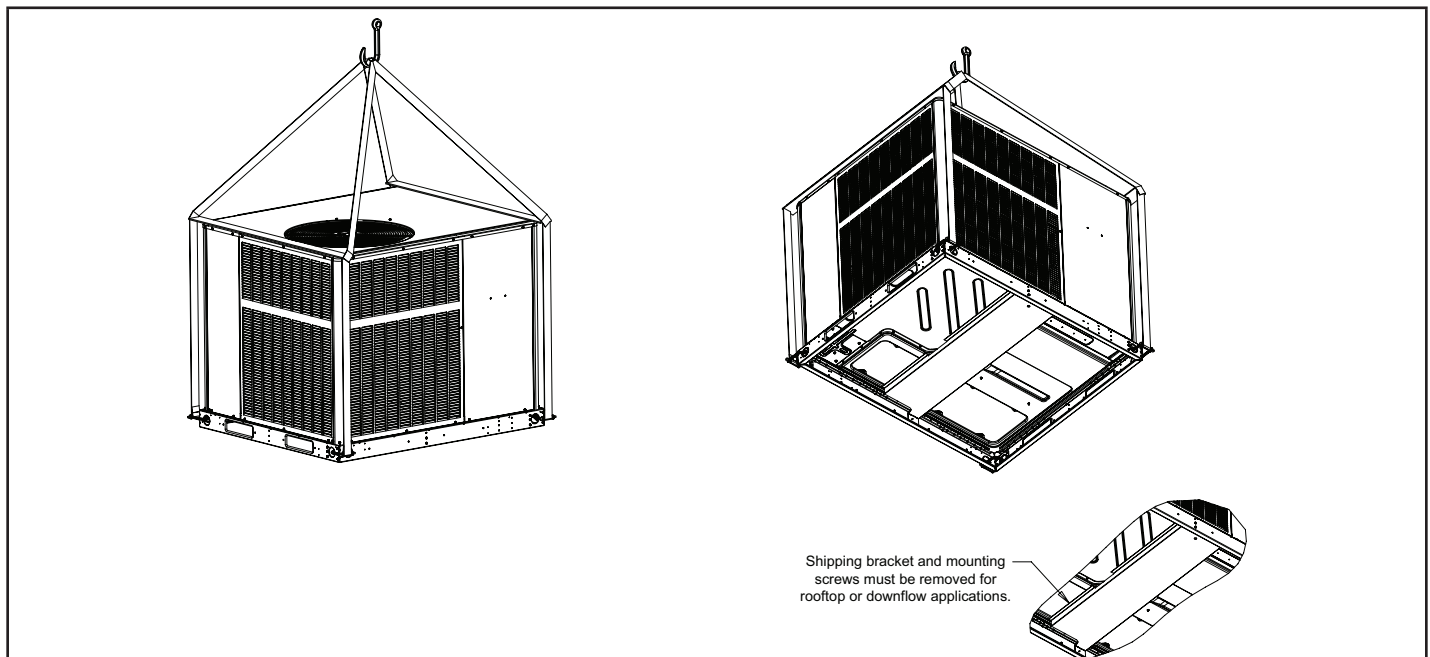

FIGURE 2

Field-Installed Economizer (Downflow)

- 1 - Before setting the unit on a roof curb, see "Roof Mounting" section for instructions on removing the shipping bracket underneath the unit.
- 2 - Remove the horizontal supply and return duct covers.
- 3 - Remove the four screws securing the downflow duct covers inside the unit. Remove and discard the covers.
- 4 - Remove the screws securing the bottom covers, and discard the bottom covers (supply and return).
- 5 - Remove screws located between the supply and return air openings that attach the blower deck to the base, and discard these screws. These screws can interfere with bottom duct connections or roof curb seals.
- 6 - Remove the close-out panel from the left-hand side of the return duct opening.
- 7 - Remove the return air panel above the return duct opening.
- 8 - Install the economizer into the unit rear panel. Wire and set up following the instructions that accompany the economizer.
- 9 - Return air duct must be field-supported.
- 10 - Unused covers and panels can be discarded.

Horizontal Air Discharge

Unit is shipped with panels covering the horizontal and downflow supply and return air openings. See FIGURE 3.

Field-Installed Economizer (Horizontal)

- 1 - Remove the horizontal duct covers over the supply and return duct openings. Covers can be discarded.

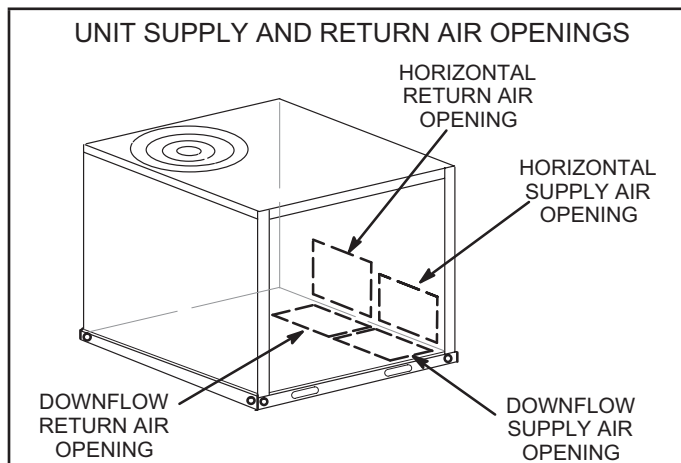

FIGURE 3

- 2 - Remove the close-out panel from the left-hand side of the return duct opening.
- 3 - Remove the return air panel above the return duct opening.
- 4 - Remove the lower (relief) hood from the economizer.

- 5 - Install the economizer into the unit rear panel. Wire and set up following the instructions that accompany the economizer.
- 6 - Install return air duct to the economizer at the former location of the relief hood.
- 7 - Cut a 20" wide X 14" high opening in the return air duct and install the economizer relief hood. See FIGURE 4.
- 8 - Return air duct must be field-supported.
- 9 - Unused covers and panels can be discarded.

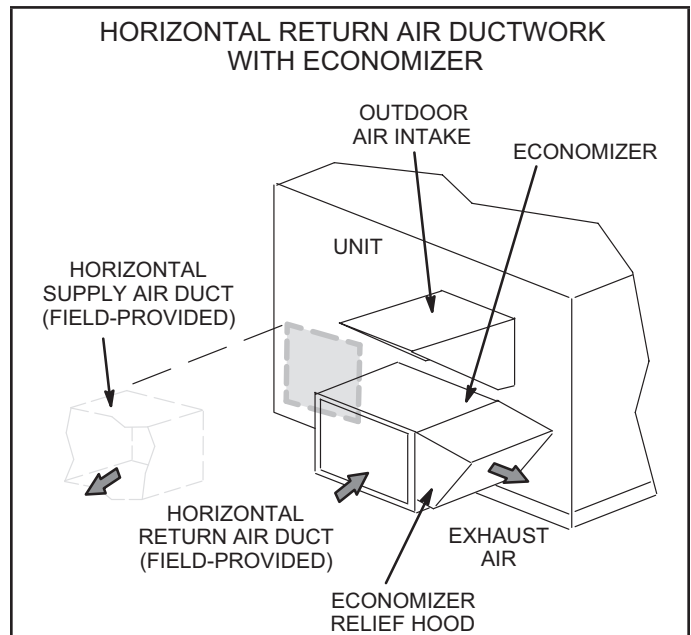

FIGURE 4

Condensate Drains

This package unit is equipped with a 3/4" FPT coupling for condensate line connection. Plumbing must conform to local codes. Use a sealing compound on male pipe threads.

Do not operate unit without a drain trap. The condensate drain is on the negative pressure side of the blower; therefore, air being pulled through the condensate line will prevent positive drainage without a proper trap. **The condensate drain line must be properly trapped, routed to a suitable drain and primed prior to unit commissioning.**

NOTE - Install drain lines and trap so they do not block service access to the unit.

See FIGURE 5 for proper drain arrangement. The drain line must pitch to an open drain or pump to prevent clogging of the line. Seal around the drain connection with suitable material to prevent air leakage into the return air system.

To prime trap, pour several quarts of water into drain, enough to fill drain trap and line.

CAUTION - Drain lines should be hand-tightened only. Do not use tools to tighten fitting into drain.

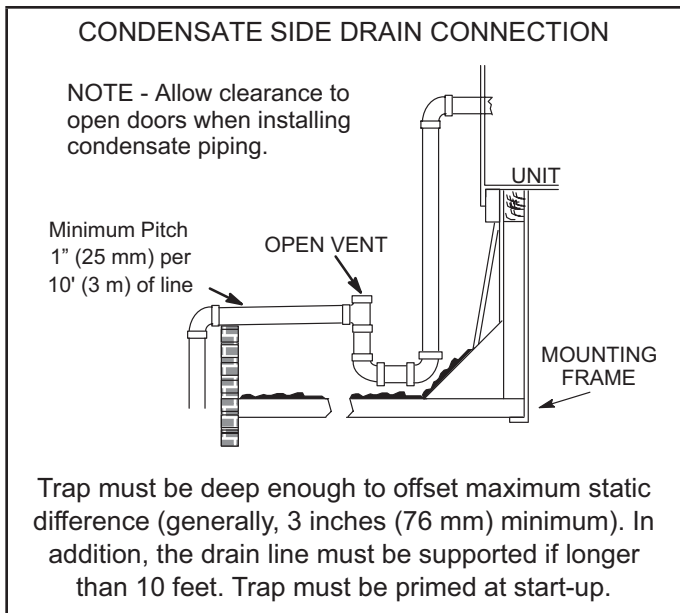

FIGURE 5

Connect Gas Piping

Before connecting field-provided piping, check with gas company or authorities having jurisdiction for local code requirements. When installing gas supply piping, length of run from gas meter must be considered in determining pipe size for 0.5" w.c. (.12kPa) maximum pressure drop. Do not use supply pipe smaller than unit gas connection. Operating pressures at the unit gas connection must be as shown in TABLE 1.

TABLE 1

OPERATING PRESSURE at GAS CONNECTION - in. w.c.

Natural Gas		LP / Propane Gas	
Min.	Max.	Min.	Max.
4.5	10.5	11	13

When making piping connections a drip leg should be installed on vertical pipe runs to serve as a trap for sediment or condensate. A 1/8" N.P.T. plugged tap is located on gas valve for test gauge connection. Refer to Heating Start-Up section for tap location. Install a ground joint union between the gas control manifold and the main manual shut-off valve. Piping must be installed according to allow the door to open properly.

Compounds used on threaded joints of gas piping shall be resistant to the action of liquefied petroleum gases.

The gas supply line is routed through the gas entry location on the side of the unit. See FIGURE 6. A grommet is provided in the instruction bag and should be used to seal gas supply line to gas entry of control compartment.

An optional bottom-entry gas kit is available for these units. See the instructions in that kit for proper installation details.

The gas supply line is routed through the gas entry location on the side of the unit. See FIGURE 6. A grommet is provided in the instruction bag and should be used to seal gas supply line to gas entry of control compartment.

An optional bottom-entry gas kit is available for these units. See the instructions in that kit for proper installation details.

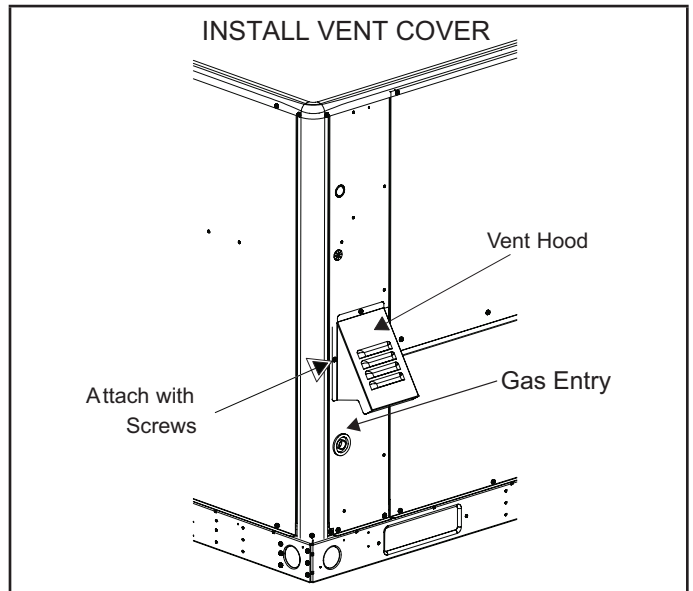

FIGURE 6

Pressure Test Gas Piping

When pressure testing gas lines, the gas valve must be disconnected and isolated. Gas valves can be damaged if subjected to more than 0.5 psig (3.48kPa). See FIGURE 7.

NOTE - Codes may require that manual main shut-off valve and union (furnished by installer) be installed in gas line external to unit. Union must be of the ground joint type.

After all connections have been made, check all piping connections for gas leaks. Also check existing unit gas connections up to the gas valve; loosening may occur during installation. Use a leak detection solution or other preferred means. Do not use matches candles or other sources of ignition to check for gas leaks.

⚠ CAUTION

Some soaps used for leak detection are corrosive to certain metals. Carefully rinse piping thoroughly after leak test has been completed. Do not use matches, candles, flame or other sources of ignition to check for gas leaks.

⚠ WARNING



Danger of explosion. Can cause injury or product or property damage. Do not use matches, candles, flame or other sources of ignition to check for leaks.

NOTE - In case emergency shut down is required, turn off the main manual shut-off valve and disconnect main power to unit. These devices should be properly labeled by the installer.

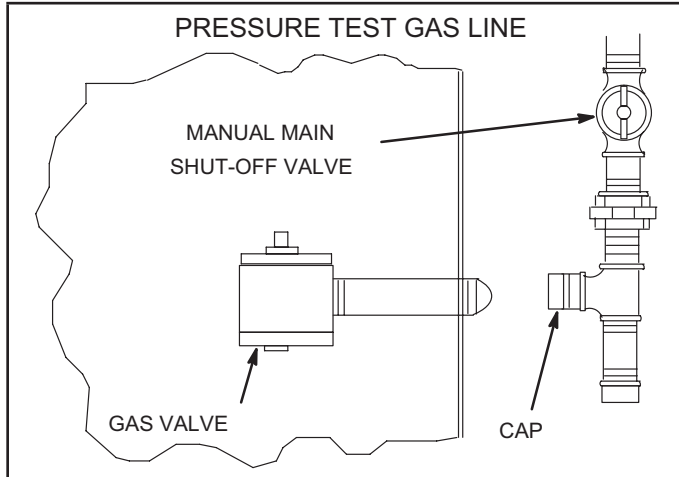

FIGURE 7

NOTE - LP/Propane Units, Tanks, and Piping.

Units are shipped equipped for use with natural gas, but can be converted to LP/propane in the field by an approved licensed technician. If conversion is required, use the approved conversion kit.

When converting a low-NOx unit to propane, the NOx inserts must be removed.

All LP/propane gas equipment must conform to the safety standards of the National Fire Protection Association.

For satisfactory operation, LP/propane gas pressure must be a minimum of 11" w.c. at the unit under full load.

Complete information regarding tank sizing for vaporization, recommended regulator settings, and pipe sizing is available from most regulator manufacturers and LP/propane gas suppliers.

⚠ CAUTION

If a flexible gas connector is required or allowed by the authority that has jurisdiction, black iron pipe shall be installed at the gas valve and must extend outside the cabinet. The flexible connector can then be added between the black iron pipe and the gas supply line.

Install Vent Hood

The unit is shipped with the vent hood inside the control compartment. Locate the vent hood and attach to side of utility panel with screws provided in the instruction bag. See FIGURE 6.

High Altitude Derate

The input rate shown on the rating plate is for elevations up to 2000 feet. For elevations from 2001 to 4500 feet, the input rate is reduced by 5%. For elevations above 4500 feet, refer to the National Fuel Gas Code Z223.1 (latest edition) or the Canadian Installation Codes CAN/CGA-B149.1 & B149.2 for further details.

To check this pressure:

- 1 - Slide the gas valve switch to the "OFF" position (see FIGURE 9).
- 2 - Remove plug on valve marked "OUTLET PRESSURE".
- 3 - Install a water manometer.
- 4 - Slide the gas valve switch to the "ON" position and initiate a call for heat. If manifold pressure must be adjusted, remove cap from pressure regulator and turn adjustment screw clockwise to increase pressure or counterclockwise to reduce pressure.
- 5 - After checking pressure, turn gas off, remove manometer fitting, and replace pipe plug and regulator cap.
- 6 - Put furnace in operation and check plug for leaks using soapy solution.

NOTE - This is the only permissible derate for these units.

Electrical Connections

All wiring should be done in accordance with the National Electrical Code, ANSI/NFPA No. 70 (latest edition); Canadian Electrical Code Part 1, CSA C22.1 (latest edition); or local codes where they prevail. Use wiring with a temperature limitation of 75°C minimum. Run the 208, 230, or 460 volt, 60 hertz electric power supply through a fused disconnect switch to the control box of the unit and connect as shown in the wiring diagram located on the inside of the control access panel.

Power supply to the unit must be N.E.C. Class 1, and must comply with all applicable codes. A disconnect switch should be field provided for the unit; follow local codes to determine what type of switch to use. The switch must be separate from all other circuits. If any of the wire supplied with the unit must be replaced, replacement wire must be of the type shown on the wiring diagram. Electrical wiring must be sized to carry minimum circuit ampacity marked on the unit. Use copper conductors only. Each unit must be wired with a separate branch circuit and be properly fused.

An optional bottom-entry power kit is available for these units. See the instructions in that kit for proper installation details.

THERMOSTAT WIRING

A - Thermostat Location

Room thermostat mounts vertically on a standard 2" X 4" handy box or on any non-conductive flat surface.

Locate thermostat approximately 5 feet (1524mm) above the floor in an area with good air circulation at average temperature. Avoid locating the room thermostat where it might be affected by:

- Drafts or dead spots behind doors and in corners
- Hot or cold air from ducts
- Radiant heat from sun or appliances
- Concealed pipes and chimneys

B - Control Wiring

- 1 - Route thermostat cable or wires from subbase to control panel (refer to unit dimensions to locate bottom and side power entry).

IMPORTANT - Unless field thermostat wires are rated for maximum unit voltage, they must be routed away from line voltage wiring.

Use 18 AWG wire for all applications using remotely installed thermostats.

- 2 - Install thermostat assembly in accordance with instructions provided with thermostat.
- 3 - Connect thermostat wiring to leads in control panel. Wire as shown in FIGURE 8.
- 4 - Four wires are required for cooling.
- 5 - A thermostat capable of two-stage cooling is required when economizers are installed.

C - Heat Anticipator

The heat anticipator setting is **0.75 amp**. It is important that the anticipator setpoint be correct. Too high of a setting will result in longer heat cycles and a greater temperature swing in the conditioned space. Reducing the value below the correct setpoint will give shorter "ON" cycles and may result in the lowering of the temperature within the conditioned space.

IMPORTANT - Terminal connections at the wall plate or subbase must be made securely. Loose control wire connections may allow unit to operate but not with proper response to room demand.

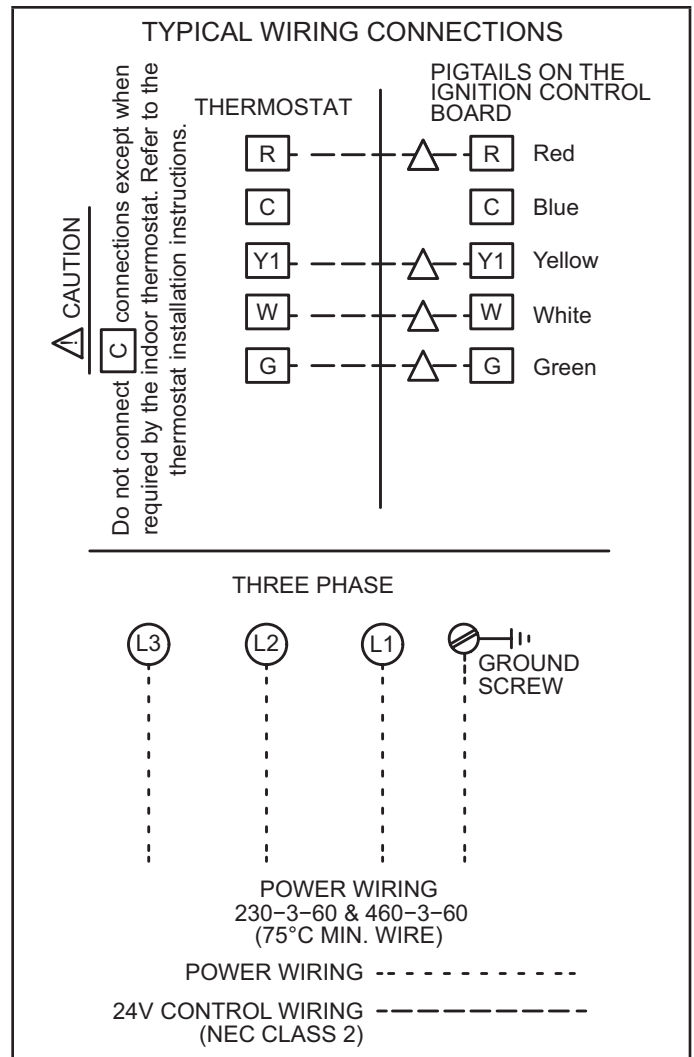

FIGURE 8

Blower Operation and Adjustments

Units are equipped with direct drive blowers.

! IMPORTANT

Three phase scroll compressors must be phased sequentially for correct compressor and blower rotation. Follow "COOLING START-UP" section of installation instructions to ensure proper compressor and blower operation.

Initiate blower demand at thermostat according to instructions provided with thermostat. Unit will cycle on thermostat demand. The following steps apply to applications using a typical thermostat.

- 1 - Blower operation is manually set at the thermostat subbase fan switch. With fan switch in **ON** position, blowers will operate continuously.
- 2 - With fan switch in **AUTO** position, the blowers will cycle with demand. Blowers and entire unit will be off when system switch is in **OFF** position.

BLOWER DATA

QGA036S4D

Model No.		External Static (in. w.g.)									
		0.1	0.2	0.3	0.4	0.5	0.6	0.7	0.8	0.9	1.0
Tap 1 (Fan Only)	cfm	819	756	692	625	564	503	436	367	---	---
	RPM	542	580	619	661	701	737	776	810	---	---
	Watts	91	96	102	107	112	117	123	127	---	---
Tap 2 (Low Cooling)	cfm	1271	1226	1193	1149	1105	1062	1016	970	928	884
	RPM	760	786	809	836	862	889	919	947	974	1001
	Watts	262	270	277	285	292	301	309	317	325	333
Tap 3 (High Cooling)	cfm	1587	1542	1507	1473	1439	1402	1365	1332	1298	1254
	RPM	906	929	953	973	994	1013	1036	1057	1080	1102
	Watts	472	482	492	501	511	520	529	539	549	557
Tap 4 (54k Heat Exchanger)	cfm	1058	1008	958	905	856	802	749	700	650	598
	RPM	654	683	712	742	779	810	842	872	902	934
	Watts	164	169	175	182	188	195	201	208	213	221
Tap 5 (54k Heat Exchanger)	cfm	1318	1276	1235	1202	1157	1116	1072	1028	985	945
	RPM	786	813	836	860	886	910	939	968	995	1022
	Watts	293	302	309	317	324	332	341	350	358	367
Tap 4 (72k Heat Exchanger)	cfm	1120	1063	1003	938	871	799	725	670	614	554
	RPM	588	621	643	681	714	721	758	775	794	817
	Watts	136	143	151	158	166	176	184	191	198	205
Tap 5 (72k Heat Exchanger)	cfm	1394	1344	1296	1247	1205	1152	1097	1043	984	913
	RPM	600	640	693	740	798	830	872	930	960	1012
	Watts	237	246	255	264	273	282	293	302	314	325
Tap 4 (90k Heat Exchanger)	cfm	1600	1556	1511	1468	1425	1382	1339	1295	1247	1207
	RPM	767	796	820	847	874	902	927	955	983	1010
	Watts	357	367	376	387	396	406	416	427	436	448
Tap 5 (90k Heat Exchanger)	cfm	1918	1878	1840	1805	1767	1733	1694	1660	1625	1586
	RPM	893	917	937	958	982	1002	1028	1050	1074	1095
	Watts	597	609	620	631	643	652	667	679	693	701

NOTE - All air data is measured external to unit without air filters.

BLOWER DATA**QGA042S4D**

Model No.		External Static (in. w.g.)									
		0.1	0.2	0.3	0.4	0.5	0.6	0.7	0.8	0.9	1.0
Tap 1 (Fan Only)	cfm	810	734	650	550	477	400	338	---	---	---
	RPM	466	514	566	619	668	712	749	---	---	---
	Watts	70	75	82	88	93	98	102	---	---	---
Tap 2 (Low Cooling)	cfm	1575	1519	1475	1483	1411	1376	1341	1294	1252	1209
	RPM	777	805	832	857	882	908	937	968	995	1024
	Watts	370	382	394	405	416	428	440	454	467	478
Tap 3 (High Cooling)	cfm	1899	1858	1821	1783	1751	1714	1679	1639	1604	1570
	RPM	886	910	931	954	976	998	1023	1048	1071	1092
	Watts	579	591	603	615	626	637	650	663	676	684
Tap 4 (72k Heat Exchanger)	cfm	1115	1056	996	933	866	792	733	677	610	551
	RPM	597	609	626	654	693	718	754	767	795	814
	Watts	137	145	152	159	167	178	182	190	199	206
Tap 5 (72k Heat Exchanger)	cfm	1437	1391	1342	1294	1247	1202	1152	1098	1040	974
	RPM	597	642	694	736	787	823	874	927	963	1008
	Watts	235	239	246	255	264	275	282	293	302	310
Tap 4 (90k Heat Exchanger)	cfm	1601	1551	1507	1467	1422	1379	1336	1290	1244	1203
	RPM	766	794	820	847	873	898	927	956	984	1011
	Watts	354	365	376	385	394	404	415	425	435	445
Tap 5 (90k Heat Exchanger)	cfm	1910	1872	1834	1800	1763	1730	1691	1654	1620	1579
	RPM	893	913	938	957	980	1004	1027	1048	1072	1094
	Watts	593	604	618	627	641	653	666	677	689	698

NOTE - All air data is measured external to unit without air filters.

BLOWER DATA

QGA048S4D

Model No.		External Static (in. w.g.)									
		0.1	0.2	0.3	0.4	0.5	0.6	0.7	0.8	0.9	1.0
Tap 1 (Fan Only)	cfm	1096	1033	967	898	832	755	680	613	547	482
	RPM	565	601	638	682	724	766	808	843	880	910
	Watts	131	137	144	152	161	169	177	183	190	196
Tap 2 (Low Cooling)	cfm	1907	1868	1832	1792	1755	1717	1683	1644	1607	1571
	RPM	885	900	933	954	976	1001	1022	1047	1071	1095
	Watts	499	509	521	532	542	554	565	577	589	601
Tap 3 (High Cooling)	cfm	2021	1983	1945	1911	1873	1838	1802	1768	1733	1687
	RPM	919	941	964	984	1002	1028	1050	1072	1093	1114
	Watts	625	638	651	663	674	689	702	715	728	734
Tap 4 (90k Heat Exchanger)	cfm	1545	1497	1452	1403	1356	1309	1256	1209	1159	1108
	RPM	732	759	787	816	843	871	903	934	962	995
	Watts	299	310	320	329	341	349	359	371	380	391
Tap 5 (90k Heat Exchanger)	cfm	1836	1794	1752	1711	1674	1632	1592	1553	1511	1465
	RPM	843	864	890	913	936	960	985	1009	1033	1062
	Watts	476	487	500	509	521	532	544	555	566	581
Tap 4 (108k Heat Exchanger)	cfm	1568	1515	1467	1417	1369	1324	1273	1226	1172	1117
	RPM	709	739	769	797	827	857	887	921	953	988
	Watts	292	302	313	323	334	343	354	366	377	390
Tap 5 (108k Heat Exchanger)	cfm	1939	1893	1851	1809	1769	1726	1687	1652	1612	1572
	RPM	843	867	891	917	941	969	993	1015	1041	1065
	Watts	515	526	540	553	566	579	592	604	617	630
Tap 4 (126k Heat Exchanger)	cfm	1651	1597	1553	1505	1461	1416	1369	1316	1264	1221
	RPM	746	776	803	831	857	887	914	944	977	1007
	Watts	338	350	360	371	381	392	403	415	426	437
Tap 5 (126k Heat Exchanger)	cfm	1943	1899	1855	1816	1773	1733	1692	1655	1616	1576
	RPM	857	880	904	928	953	977	1001	1025	1048	1073
	Watts	528	540	552	565	578	590	603	615	629	641

NOTE - All air data is measured external to unit without air filters.

BLOWER DATA

QGA060S4D

Model No.		External Static (in. w.g.)									
		0.1	0.2	0.3	0.4	0.5	0.6	0.7	0.8	0.9	1.0
Tap 1 (Fan Only)	cfm	1393	1332	1275	1224	1166	1106	1043	979	909	836
	RPM	620	654	690	722	758	793	831	872	913	946
	Watts	184	192	201	209	218	226	236	246	256	264
Tap 2 (Low Cooling)	cfm	1907	1868	1832	1792	1755	1717	1683	1644	1607	1571
	RPM	885	909	933	954	976	1001	1022	1047	1071	1095
	Watts	478	509	521	532	542	554	565	577	589	601
Tap 3 (High Cooling)	cfm	2387	2350	2317	2271	2245	2210	2172	2149	2098	2057
	RPM	967	983	1004	1031	1049	1069	1093	1109	1125	1145
	Watts	784	795	809	829	841	856	870	878	880	885
Tap 4 (90k Heat Exchanger)	cfm	1469	1410	1356	1304	1247	1196	1138	1079	1020	947
	RPM	642	678	711	739	776	809	845	880	919	957
	Watts	207	217	226	234	244	253	263	273	283	293
Tap 5 (90k Heat Exchanger)	cfm	1838	1792	1744	1699	1654	1612	1568	1519	1474	1430
	RPM	769	796	822	850	872	899	928	958	982	1011
	Watts	375	382	392	404	414	424	437	449	460	471
Tap 4 (108k Heat Exchanger)	cfm	1648	1595	1546	1493	1447	1398	1352	1305	1256	1211
	RPM	729	759	786	813	843	870	897	927	960	993
	Watts	298	309	318	328	338	347	357	367	379	390
Tap 5 (108k Heat Exchanger)	cfm	2033	1990	1946	1904	1862	1821	1781	1743	1705	1665
	RPM	868	893	914	940	961	986	1006	1030	1051	1075
	Watts	525	540	550	562	573	585	596	608	619	633
Tap 4 (126k Heat Exchanger)	cfm	1639	1584	1539	1492	1446	1399	1355	1308	1258	1210
	RPM	737	766	795	825	853	881	909	941	970	1005
	Watts	301	311	322	332	342	353	362	373	383	394
Tap 5 (126k Heat Exchanger)	cfm	1988	1945	1899	1856	1822	1785	1743	1707	1671	1636
	RPM	864	890	914	939	961	987	1011	1035	1058	1081
	Watts	507	520	532	545	557	569	581	593	605	616

NOTE - All air data is measured external to unit without air filters.

BLOWER DATA**AIR RESISTANCE DATA - in. w.g.**

Air Volume cfm	Wet Indoor Coil			Optional Economizer
	036, 042	048	060	
600	0.01	0.01	---	0.02
700	0.01	0.01	0.01	0.03
800	0.01	0.01	0.01	0.04
900	0.02	0.01	0.01	0.05
1000	0.02	0.02	0.02	0.06
1100	0.02	0.02	0.02	0.07
1200	0.03	0.02	0.02	0.08
1300	0.03	0.03	0.03	0.10
1400	0.04	0.03	0.03	0.12
1500	0.05	0.04	0.03	0.13
1600	0.05	0.05	0.03	0.15
1700	0.05	0.05	0.04	0.18
1800	0.06	0.05	0.04	0.20
1900	0.06	0.06	0.04	0.21
2000	0.07	0.06	0.05	0.24

Cooling Start-Up

A - Operation

- 1 - Initiate cooling demands according to instructions provided with thermostat.
- 2 - When the thermostat calls for cooling, R is closed to Y (see the wiring diagrams). This action completes the low voltage control circuit, energizing the compressor, condenser fan motor, and blower motor.
- 3 - Unit compressors have internal protection. In the event there is an abnormal rise in the temperature of the compressor, the protector will open and cause the compressor to stop.
- 4 - A combustion air inducer operates for the first 10 seconds of every cooling cycle to prevent insects from nesting in the flue outlet.

Blower Delay – Cooling

The circulating air blower is controlled by a timing circuit in the integrated blower/ignition control. Timings are not adjustable. Blower “ON” delay is 5 seconds after the compressor starts and blower “OFF” timing is 60 seconds after the compressor shuts down.

NOTE- - There is no blower OFF delay when there is a call for G (fan only).

Continuous Fan

With the proper thermostat and sub-base, continuous blower operation is possible by closing the R to G circuit. Cooling blower delay is also functional in this mode.

- 5 - Units contain one refrigerant circuit or stage.
- 6 - Unit is charged with R-410A refrigerant. See unit rating plate for correct amount of charge.
- 7 - Refer to Refrigerant Charge and Check section for proper method to check refrigerant charge.

B - Three-Phase Scroll Compressor Voltage Phasing

Three phase scroll compressors must be phased sequentially to ensure correct compressor and blower rotation and operation. Compressor and blower are wired in phase at the factory. Power wires are color-coded as follows: line 1-red, line 2-yellow, line 3-blue.

- 1 - Observe suction and discharge pressures and blower rotation on unit start-up.
- 2 - Suction pressure must drop, discharge pressure must rise and blower rotation must match rotation marking.

If pressure differential is not observed or blower rotation is not correct:

- 3 - Disconnect all remote electrical power supplies.
- 4 - Reverse any two field-installed wires connected to the line side of contactor.

- 5 - Make sure the connections are tight.

Discharge and suction pressures should operate at their normal start-up ranges.

C - Refrigerant Charge and Check

WARNING-Do not exceed nameplate charge under any condition.

This equipment is a self-contained, factory-optimized refrigerant system. The unit should not require adjustments to system charge when properly installed. If unit performance is questioned, perform the following checks.

Ensure unit is installed per manufacturers instructions and that line voltage and air flow are correct. Refer to TABLE 2 for proper performance value. The indoor metering device varies by model. When checking performance of a unit using an orifice for metering, refer to the suction superheat value to judge performance. When checking performance of a unit that uses an expansion valve for metering, refer to the subcooling value to judge system performance.

If the measured performance value varies from table value allowance, check internal seals, service panels and duct work for air leaks, as well as restrictions and blower speed settings. If unit performance remains questionable, remove system charge, evacuate to 500 microns, and weigh in refrigerant to nameplate charge. It is critical that the exact charge is re-installed. Failure to comply will compromise system performance.

If unit performance is still questionable, check for refrigerant-related problems, such as blocked coil or circuits, malfunctioning metering device or other system components.

TABLE 2

COOLING SYSTEM PERFORMANCE VALUES

Model	Suction Superheat +/- 3	Liquid Subcooling +/- 2
3 Ton	14	
3.5 Ton	14	
4 Ton	16	
5 Ton	17	

Based on outdoor ambient temperature of 82°F and indoor entering air of 80°F db / 6°F wb.

TABLE 3
COOLING PERFORMANCE

80°F DB / 67°F WB Return Air		Air Temperature Entering Outdoor Coil, °F											
Cooling Input (1000 BTU)	Pressure	65	70	75	80	82	85	90	95	100	105	110	115
36	Suction	135	137	140	142	143	144	147	149	151	152	154	155
42		129	132	135	139	140	141	143	145	146	147	148	149
48		132	136	139	143	144	145	146	147	149	151	152	154
60		130	131	133	134	135	136	139	141	144	146	149	152
36	Liquid	250	275	301	326	336	351	375	399	423	446	470	493
42		248	271	293	316	325	339	362	385	411	436	462	487
48		265	286	308	329	338	352	376	400	427	455	482	509
60		256	276	296	316	324	340	365	386	415	438	473	503

D - Compressor Controls

See unit wiring diagram to determine which controls are used on each unit. Optional controls are identified on wiring diagrams by arrows at junction points.

1 - High Pressure Switch (S4)

The high pressure switch is an auto-reset SPST N.C. switch which opens on a pressure rise.

S4 is located in the compressor discharge line and is wired in series with the compressor contactor coil.

When discharge pressure rises to 590±10 psig (4068±69kPa), indicating a problem with the system, the switch opens. The respective compressor is de-energized but the economizer can continue to operate. Auto-reset switches close at 418±20psig (2882±138kPa).

2 - Compressor High Temperature Limit (S173)

The temperature limit switch S5 is located on the top of Interlink compressors and is wired in series with the high pressure switch S4.

Gas Heat Start-Up

FOR YOUR SAFETY READ BEFORE LIGHTING

⚠ WARNING



Electric shock hazard. Can cause injury or death. Do not use this unit if any part has been under water. Immediately call a qualified service technician to inspect the unit and to replace any part of the control system and any gas control which has been under water.

⚠ WARNING



Danger of explosion. Can cause injury or product or property damage. If overheating occurs or if gas supply fails to shut off, shut off the manual gas valve to the appliance before shutting off electrical supply.

⚠ WARNING



Electric shock hazard. Can cause injury or death. Before attempting to perform any service or maintenance, turn the electrical power to unit OFF at disconnect switch(es). Unit may have multiple power supplies.

⚠ WARNING

SMOKE POTENTIAL

The heat exchanger in this unit could be a source of smoke on initial firing. Take precautions with respect to building occupants and property. Vent initial supply air outside when possible.

BEFORE LIGHTING smell all around the appliance area for gas. Be sure to smell next to the floor because some gas is heavier than air and will settle on the floor.

The gas valve may be equipped with either a gas control lever or gas control knob. Use only your hand to push the lever or turn the gas control knob. Never use tools. If the lever will not move or the knob will not push in or turn by hand, do not try to repair it. Call a qualified service technician. Force or attempted repair may result in a fire or explosion.

⚠ WARNING	
	Danger of explosion. Can cause injury or death. Do not attempt to light manually. Unit has a direct spark ignition system.

This unit is equipped with an automatic spark ignition system. There is no pilot. In case of a safety shutdown, move thermostat switch to **OFF** and return the thermostat switch to **HEAT** to reset ignition control.

A - Placing Unit In Operation

⚠ WARNING	
	Danger of explosion and fire. Can cause injury or product or property damage. You must follow these instructions exactly.

Gas Valve Operation

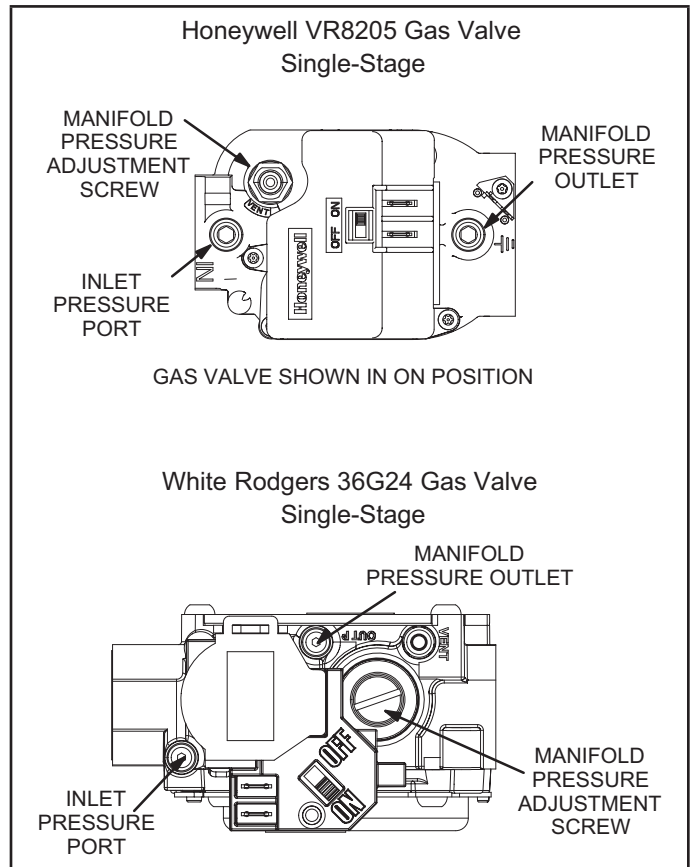

FIGURE 9

To Light Main Burners

- 1 - Turn off electrical power to unit.
- 2 - Turn the thermostat to lowest setting.
- 3 - Slide the gas valve switch to the "ON" position (see FIGURE 9).
- 4 - Turn on electrical power to the unit.
- 5 - Set the room thermostat to the desired temperature. (If the thermostat "set" temperature is above room temperature after the pre-purge time expires, main burners will light).

To Shut Down Main Burners

- 1 - Turn off electrical power to unit.
- 2 - Slide the gas valve switch to the "OFF" position (see FIGURE 9).

⚠ WARNING	
	Danger of explosion. Can cause injury or death. Do not attempt to light manually. Unit has a direct spark ignition system.

Heating Operation and Adjustments

A - Heating Sequence of Operation

When the thermostat calls for heating, R is closed to W. The following describes the gas heating sequence of operation.

- 1 - A call for heat from the room thermostat starts the combustion air blower and the circulating air blower.
- 2 - When the speed of the combustion air blower reaches proper RPM, the pressure switch closes, initiating a re-purge period (30 seconds nominal).
- 3 - When the pre-purge period has expired, the ignition control energizes the main gas valve and spark electrode for a period of 10 seconds.
- 4 - If the flame sensor does not sense that a flame has been established in the 10-second interval, then the ignition control will de-energize the gas valve, and begins a 30 second inter-purge period, then initiates another trial for ignition.
- 5 - The ignition control is designed to repeat this "trial for ignition" a total of three times. If, at the end of the third trial, flame still has not been established, then the ignition control will try to light again 1 hour later. The 1-hour retry is indefinite. The ignition control can be reset by interrupting the unit power or the thermostat circuit.
- 6 - Once flame sense has been established, the circulating air blower is energized after a 30 second blower on delay.
- 7 - When the thermostat is satisfied, the combustion air blower and gas valve are de-energized. The circulation air blower will continue to run for a short period after the furnace is shut down.

B - Safety Controls

The control circuit includes the following safety controls:

Limit Control

This control is located inside the heating compartment and is designed to open at abnormally high circulating air temperatures. It resets automatically. The limit control operates when a high temperature condition, caused by inadequate airflow, occurs. This closes the main gas valve.

Pressure Switch

If the combustion air blower should fail, the pressure switch prevents the spark electrode and gas valve from being energized.

Flame Sensor

If the ignition control does not receive a signal from the flame sensor indicating that the burners have established flame, the gas valve closes after the 10-second trial for ignition period.

Rollout Switch

The switch is located on the top of the burner box. In the event of a sustained main burner roll-out, the roll-out switch shuts off the ignition control and closes the main gas valve. To reset, push the button on top of the switch.

Blower Delay – Heating

- The circulating air blower "OFF" delay is 120 seconds after shutting down the burners. This delay is not adjustable.
- The circulating air blower "ON" delay is 120 seconds after "W" signal is received to allow the furnace to warm up.

C - Ignition Control Diagnostic LEDs

TABLE 4

IGNITION CONTROL HEARTBEAT LED STATUS

LED Status	Flashing Rate	Fault Description
Slow Flash	One flash per second	Normal operation: No call for heat.
Fast Flash	Two flashes per second	Normal operation: Call for heat.
2	Two flashes in 1 second with 1-second pause	System lockout: Failed to detect or sustain flame.
3	Three flashes in 1.5 seconds with 1-second pause.	Pressure switch senses incorrect pressure or gas valve coil is open.
4	Four flashes in 2 seconds with 1-second pause	High limit or roll-out switch open
5	Five flashes in 2.5 seconds with 1-second pause	Flame sensed and gas valve not energized.
Steady Off		Internal failure: Micro-controller failure; self-check

D - Limit Controls

Limit controls are factory-set and are not adjustable. The primary limit is located in the heating compartment near the supply duct.

If the primary limit trips three times in the same heating cycle, heating operation will de-energize. Heating will automatically restart after one hour if a heating demand is present. To initiate heating during the one hour timed-off interval, reset the thermostat.

E - Heating Adjustment

Main burners are factory-set and do not require adjustment.

The following manifold pressures are listed on the gas valve.

Natural Gas Units - High Fire - 3.5" w.c.

Service

The unit should be inspected once a year by a qualified service technician.

⚠ CAUTION

Label all wires prior to disconnection when servicing controls. Wiring errors can cause improper and dangerous operation. Verify proper operation after servicing.

A - Filters

Air filters are not supplied with the unit. A field-provided air filter must always be installed ahead of the evaporator coil and must be cleaned or replaced if necessary. Dirty filters will reduce the airflow of the unit. All units are equipped with a factory-installed filter rack. Use two 20 X 20 X 1" (508 X 508 X 51mm) filters. Refer to local codes or appropriate jurisdiction for approved filters.

To change filters, remove the blower access panel and slide the filters out of the internal rack. See FIGURE 10.

Approved filters should be checked monthly and replaced when necessary. Take note of air flow direction marking on filter frame when reinstalling filters.

NOTE - Filters must be U.L.C. certified or equivalent for use in Canada.

An optional tool-less filter access kit is available. The kit includes two new blower panels (one smaller panel secured with screws, the other with twist latches) to provide access for filter changes without any hand tools.

B - Lubrication

All motors are lubricated at the factory. No further lubrication is required.

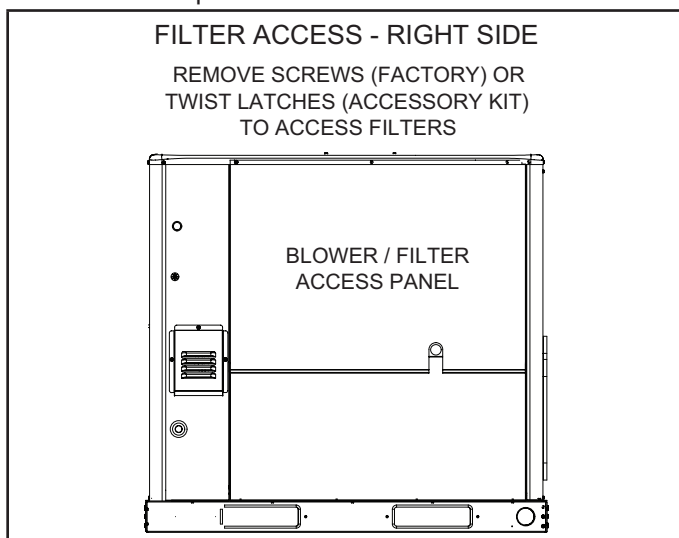

FIGURE 10

C - Burner and Burner Orifices

Periodically examine burner flames for proper appearance during the heating season. Before each heating season examine the burners for any deposits or blockage which may have occurred.

To check or change burners or burner orifices:

- 1 - **Close the main manual gas shutoff valve and turn off all power to unit.**
- 2 - Remove the access panel.
- 3 - Disconnect the union in the gas supply line upstream of the gas valve and downstream of the manual shutoff valve.
- 4 - Label wires going to the gas valve, then disconnect the wires.
- 5 - To change orifice:
 - a - Remove screws that fasten the manifold to the burner box assembly and remove the manifold.
 - b - Remove the orifices, then install replacement orifices.
 - c - To reassemble: Reverse above steps, making sure orifices are inserted into the orifice holders on the back end of the burners, and that burners are level and centered on each burner opening in the vest panel.
- 6 - To remove or service burners:
 - a - Label and disconnect the wires to the roll-out switch and disconnect the ignitor and flame sensor leads at the ignition control.
 - b - Remove the screws that secure the burner box assembly to the vest panel and remove the assembly from the unit.
 - c - Remove the screws that fasten the burner rack and bottom shield assembly to the burner box. Burners are now accessible for removal.
 - d - To Reassemble: Reverse above steps.
- 7 - After reassembly of all parts is complete and all wires are reconnected, open the main manual gas shutoff valve; check for and correct any gas leaks. Turn electrical power on, initiate a call for heat, and check for proper burner operation.
- 8 - Install access panel.
- 9 - Locate the ignitor. Check ignitor spark gap with appropriately sized twist drills or feeler gauges. See FIGURE 11.
- 10 - Replace burners and screws securing burner. See FIGURE 12.

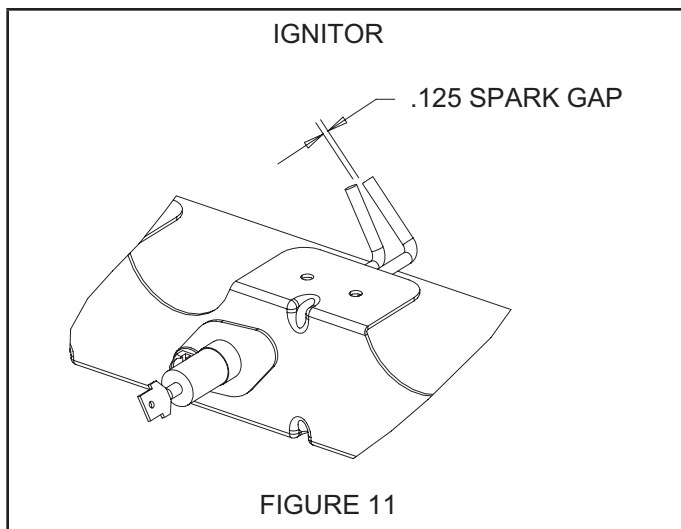

FIGURE 11

FIGURE 11

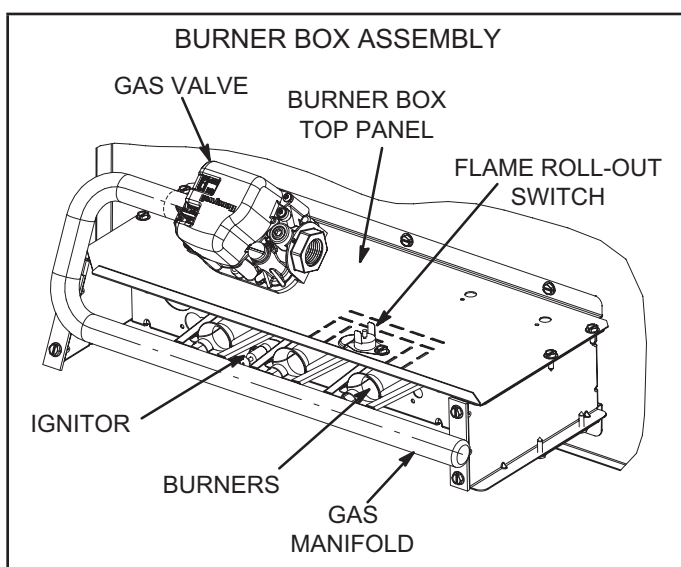

FIGURE 12

⚠ WARNING

⚡ Danger of explosion. Can cause injury or death. Do not overtighten main burner mounting screws. Snug tighten only.

D - Combustion Air Inducer

A combustion air proving switch checks combustion air inducer operation before allowing power to the gas controller. Gas controller will not operate if inducer is obstructed.

Under normal operating conditions, the combustion air inducer wheel should be checked and cleaned prior to the heating season. However, it should be examined periodically during the heating season to establish an ideal cleaning schedule.

Clean combustion air inducer as follows:

- 1 - Shut off power supply and gas to unit.
- 2 - Remove the control access panel located on the

front right side of the unit.

- 3 - Remove and retain the screws securing the vent hood to the utility panel.
- 4 - Remove and retain the screws securing the flue choke to the outside of the utility panel.
- 5 - Remove and retain the screw securing the flue tube from the inducer outlet.
- 6 - Remove and retain screws securing combustion air inducer to flue box.
- 7 - Clean inducer wheel blades with a small brush and wipe off any dust from housing. Take care not to damage exposed fan blades. Clean accumulated dust from front of flue box cover.
- 8 - Return combustion air inducer motor, flue tube, flue choke, and vent hood to original locations and secure with retained screws. It is recommended that gaskets be replaced during reassembly.

- 9 - Replace the access panel.

E - Flue Box and Heat Exchanger

With proper combustion adjustment, the heat exchanger of a gas-fired furnace will seldom need cleaning. Sooting of a gas appliance is highly irregular and once cleaned, the cause of the sooting must be determined. If the heat exchanger should become sooted, it can be cleaned as follows:

- 1 - Remove the burner assembly as outlined in the Burner and Burner Orifice Instructions section.
- 2 - Remove the combustion blower.
- 3 - At the bottom of the heating section, remove the screws holding the flue collector box. Carefully remove the flue collector box without ripping the adjacent insulation.
- 4 - Using a wire brush on a flexible wand, brush out the inside of each heat exchanger from the burner inlet and flue outlet ends.
- 5 - Brush out the inside of the flue collector box.
- 6 - Run the wire brush down the heat exchanger tubes from the flue collector end.
- 7 - If soot buildup is excessive, remove the vent motor and clean the wheel and housing. Run the wire brush down the flue extension at the outlet of the vent housing.
- 8 - After brushing is complete, blow all brushed areas with air. Vacuum as needed.
- 9 - Replace parts in the reverse order they were removed in Steps 1 through 3.
- 10 - When replacing the flue collector box, be careful so as not to tear the adjoining insulation.
- 11 - Assure that all joints on the vent side of the combustion system are air tight. Apply a high temperature (+500°F) sealing compound where needed.

F - Evaporator Coil

Inspect and clean coil at beginning of each cooling season. Clean using mild detergent or commercial coil cleaner. Flush coil and condensate drain with water taking care not to get insulation, filters and return air ducts wet.

G - Condenser Coil

Clean condenser coil annually with water and inspect monthly during the cooling season.

H - Compressor

IMPORTANT

Some scroll compressors have an internal vacuum protector that will unload scrolls when suction pressure goes below 20 psig. A hissing sound will be heard when the compressor is running unloaded. Protector will reset when low pressure in system rises above 40 psig. **DO NOT REPLACE COMPRESSOR.**

I - Supply Air Blower Wheel

Annually inspect supply air blower wheel for accumulated dirt or dust. Turn off power before attempting to remove blower access panel or to clean blower wheel.

WARNING - ELECTRIC SHOCK HAZARD. UNIT MUST BE GROUNDED IN ACCORDANCE WITH NATIONAL AND LOCAL CODES.

DIAGNOSTICS IGNITION CONTROL
 The following ignition control board LED codes will indicate normal or abnormal operations:
 1 SLOW FLASH Normal operation, no call for heat.
 2 FAST FLASH Normal operation, call for heat.
 3 FLASH System lockout failed to detect or sustain flame.
 4 FLASH Pressure switch senses incorrect pressure, aux. limit is open or gas valve coil is open.
 5 FLASH Main limit open or rollout switch open.
 6 FLASH Flame sensed and gas valve not energized.
 7 STEADY Internal failure (micro-controller failure; self check)

NOTE:
 IF ANY OF THE ORIGINAL WIRE IS REPLACED THE SAME SIZE AND TYPE WIRE MUST BE USED.
 USE COPPER CONDUCTOR ONLY, MIN 75°C WIRE

**CONNECTION DIAGRAM
 GAS/ELECTRIC (CONSTANT TORQUE BLOWER)
 3 PHASE - 230V**

NOTE: TAP 1 FOR FAN ONLY
 TAP2: COOLING STATIC COOLING
 TAP3: HIGH STATIC COOLING
 TAP4: HEATING
 TAP5: HIGH STATIC HEATING

HEAT ANTICIPATION
 SETTING: 0.75 AMP
 CONTROL CIRCUIT
 WIRING TO BE 24 VOLT,
 N.E.C. CLASS 2

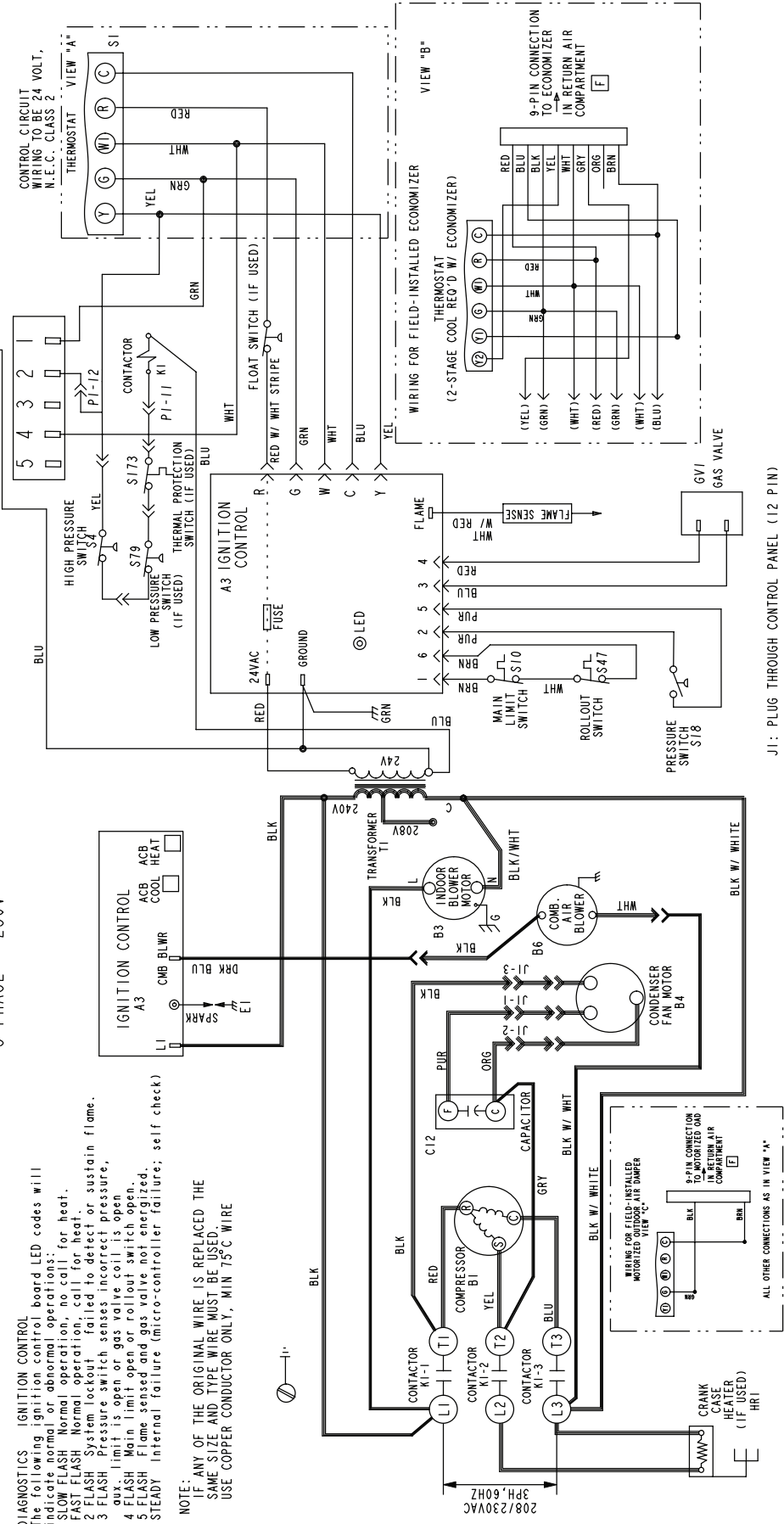

LINE VOLTAGE FIELD INSTALLED

J1: PLUG THROUGH CONTROL PANEL (12 PIN)

538132-01

FIGURE 13

WARNING-
ELECTRIC SHOCK HAZARD. UNIT
MUST BE GROUNDED IN ACCORDANCE
WITH NATIONAL AND LOCAL CODES.

DIAGNOSTICS IGNITION CONTROL

- The following ignition control board LED codes will indicate normal or abnormal operations:
- SLOW FLASH Normal operation, no call for heat.
 - FAST FLASH Normal operation, call for heat.
 - 2 FLASH System lockout failed to detect or sustain flame.
 - 3 FLASH Pressure switch senses incorrect pressure.
 - 4 FLASH Main limit open or rollout switch open.
 - 5 FLASH Flame sensed and gas valve not energized.
 - STEADY Internal failure (micro-controller failure; self check)

NOTE:
IF ANY OF THE ORIGINAL WIRE IS REPLACED THE
SAME SIZE AND TYPE WIRE MUST BE USED.
USE COPPER CONDUCTOR ONLY, MIN 75°C WIRE

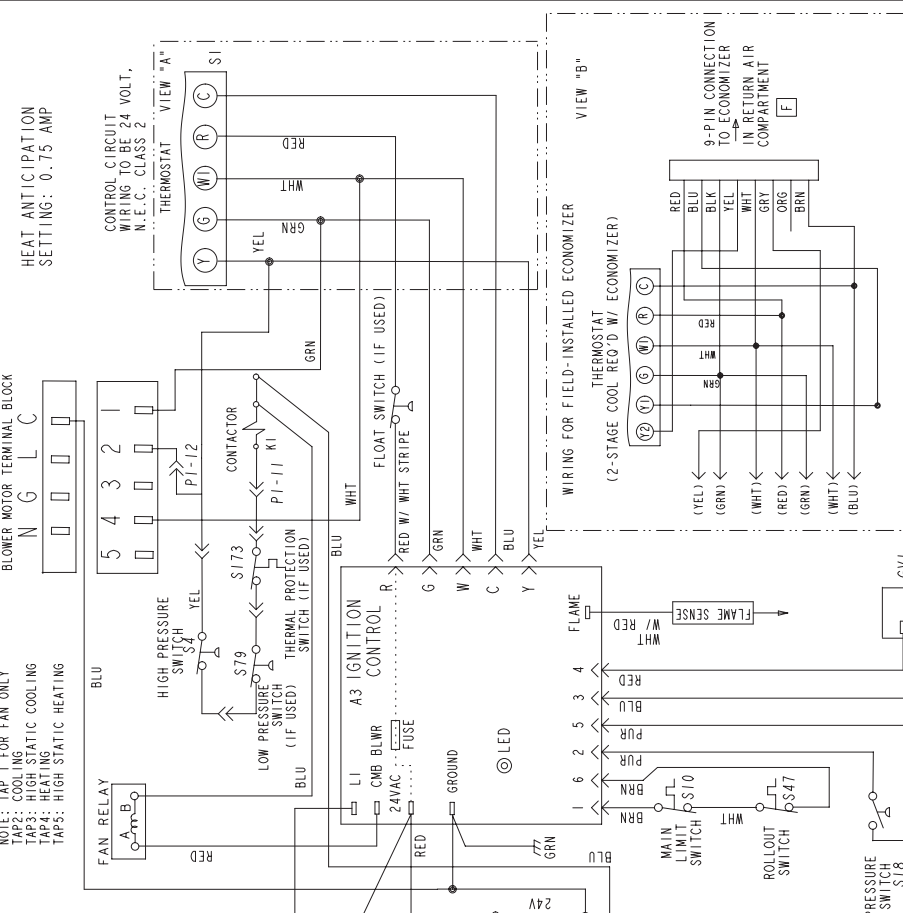
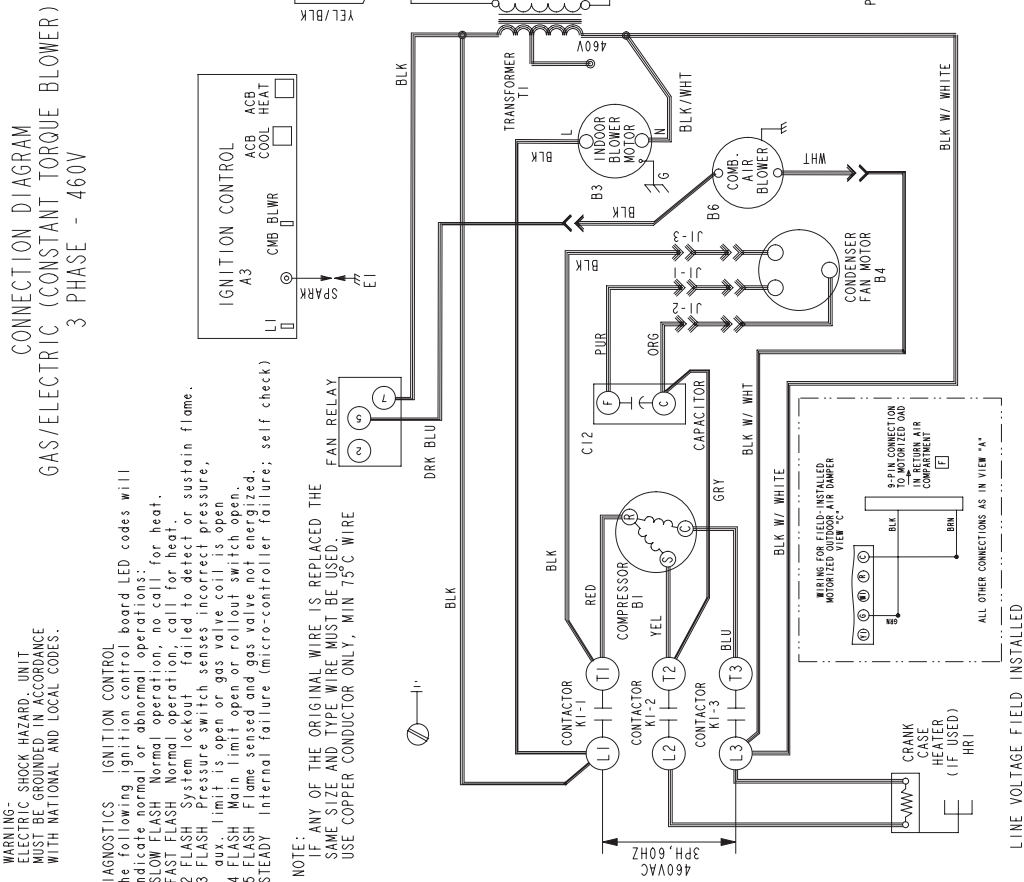

538162-01

J1: PLUG THROUGH CONTROL PANEL (12 PIN)

CONNECTION DIAGRAM
GAS/ELECTRIC (CONSTANT TORQUE BLOWER)
3 PHASE - 460V

FIGURE 14

Job Name: _____
 Store No. _____ Start-Up Date: _____
 Address: _____
 City: _____ State: _____
 Start-Up Contractor: _____
 Technician: _____
 Model No. _____
 Serial No. _____
 RTU No. _____ Catalog No. _____

Inspection and Checks			
Damage?	Yes <input type="checkbox"/>	No <input type="checkbox"/>	R22 <input type="checkbox"/> R-410A <input type="checkbox"/>
If yes, reported to: _____			
Verify factory and field-installed accessories.			
Check electrical connections. Tighten if necessary.			
Supply voltage: L1-L2 _____ L1-L3 _____ L2-L3 _____			
If unit contains a 208-230/240 volt transformer:			
Check primary transformer tap <input type="checkbox"/>			
Transformer secondary voltage: _____			

Cooling Checks												
Compressor Rotation <input type="checkbox"/> Ambient Temp. _____ Return Air Temp. _____ Supply Air Temp. _____												
	Compressor Amps			Compressor Volts			Pressures		Condenser Fan Amps			CC Heater Amps
	L1	L2	L3	L1-L2	L1-L3	L2-L3	Disch.	Suct.	L1	L2	L3	L1
1												
2												
3												
4												

Blower Checks		
Pulley/Belt Alignment <input type="checkbox"/>	Blower Rotation <input type="checkbox"/>	
Set Screws Tight <input type="checkbox"/>	Belt Tension <input type="checkbox"/>	
Nameplate Amps: _____ Volts: _____		
Motor	Amps	Volts
_____	L1 _____	L1-L2 _____
_____	L1 _____	L1-L2 _____
_____	L1 _____	L1-L2 _____

Heating Checks - Electric							
Return Air Temp. _____ Supply Air Temp. _____							
Limits Operate: <input type="checkbox"/>							
	Amps						
	L1	L2	L3		L1	L2	L3
1				10			
2				11			
3				12			
4				13			
5				14			
6				15			
7				16			
8				17			
9				18			

Heating Checks - Gas		
Fuel type: <input type="checkbox"/> Nat. LP <input type="checkbox"/> Inlet Pressure (in. w.c.): _____		
Return Air Temp. _____ Supply Air Temp. _____		
Altitude: _____ Primary Limits Operate: <input type="checkbox"/>		
Gas Valve	Manifold Pressure	
	Low Fire	High Fire
GV1		
GV1		

Control Type

Accessory Checks	
Economizer Operation	
Min. Pos. <input type="checkbox"/>	Motor Travel full open/close <input type="checkbox"/>