

# INSTALLATION INSTRUCTIONS

## Table of Contents

Dimensions.....	2
Parts Arrangement.....	2
Shipping And Packing List.....	3
General.....	3
Requirements.....	3
Unit Support.....	4
Duct Connection.....	4
Rigging Unit For Lifting.....	5
Unpacking.....	5
Downflow Air Discharge.....	5
Horizontal Air Discharge.....	6
Condensate Drains.....	6
Electrical Connections.....	7
Blower Operation And Adjustments.....	8
Heater Kit Accessory (If Used).....	11
Start-Up.....	11
Service.....	16
Equipment Checks.....	20

QCA/QHA036	3-Ton
QCA/QHA042	3-1/2-Ton
QCA/QHA048	4-Ton
QCA/QHA060	5-Ton

COOLING AND HEAT PUMP PACKAGED UNITS  
508074-01  
03/2022

## **⚠ WARNING**

Improper installation, adjustment, alteration, service or maintenance can cause property damage, personal injury or loss of life. Installation and service must be performed by a licensed professional HVAC installer or equivalent, service agency, or the gas supplier.

## **⚠ CAUTION**

As with any mechanical equipment, contact with sharp sheet metal edges can result in personal injury. Take care while handling this equipment and wear gloves and protective clothing.

**RETAIN THESE INSTRUCTIONS FOR FUTURE REFERENCE**

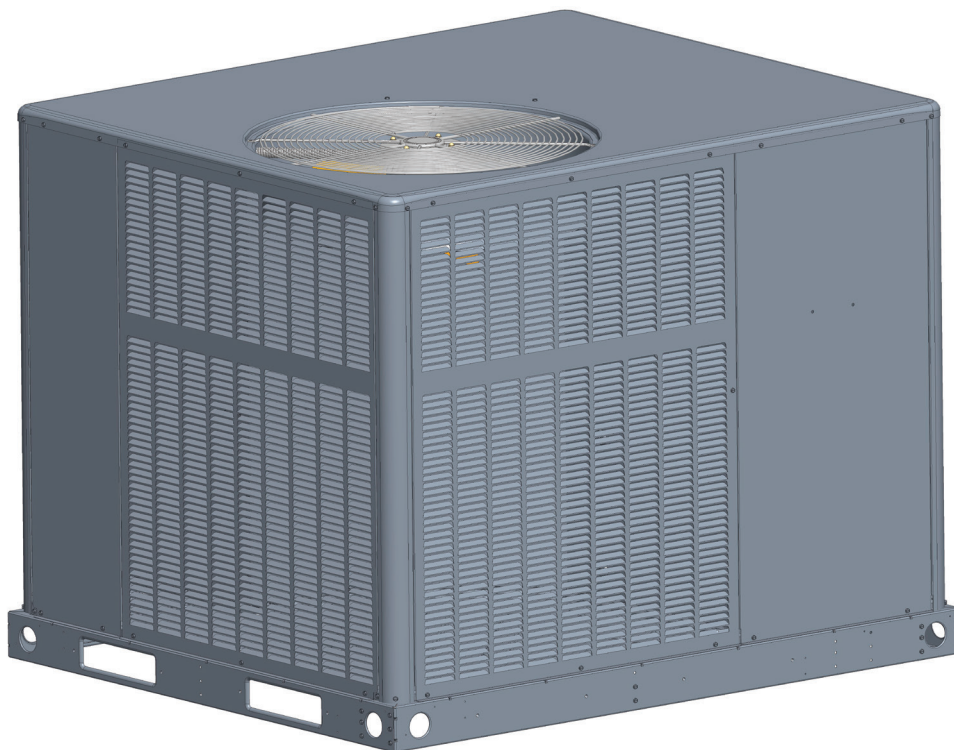

**DIMENSIONS in. (mm) - QCA/QHA036, 042, 048, 060**

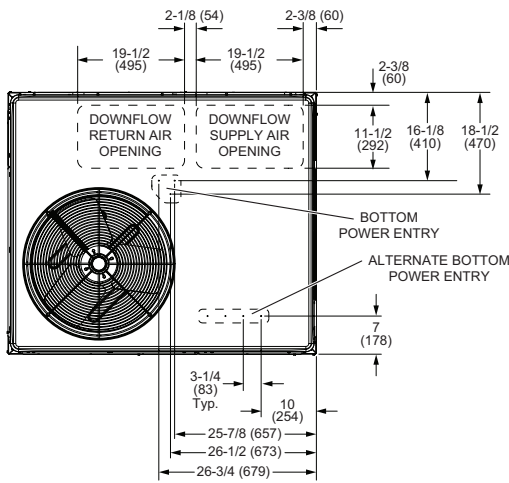

**TOP VIEW (Base)**

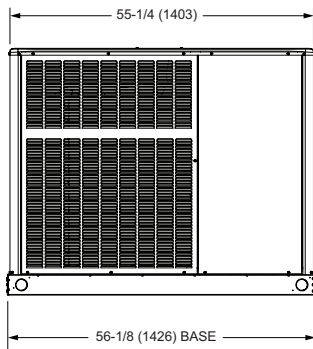

**FRONT VIEW**

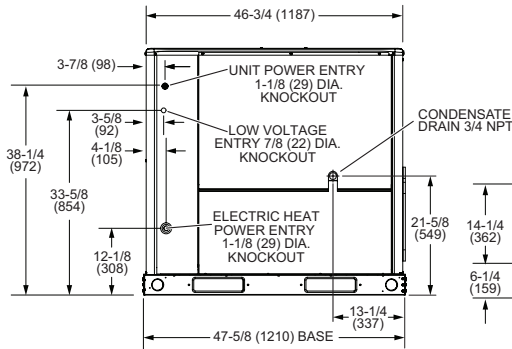

**RIGHT SIDE VIEW**

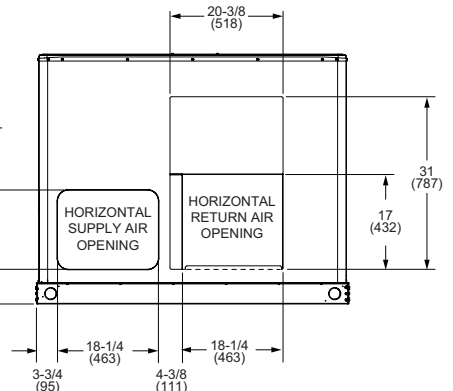

**BACK VIEW**

**PARTS ARRANGEMENT - QCA/QHA036, 042, 048, 060**

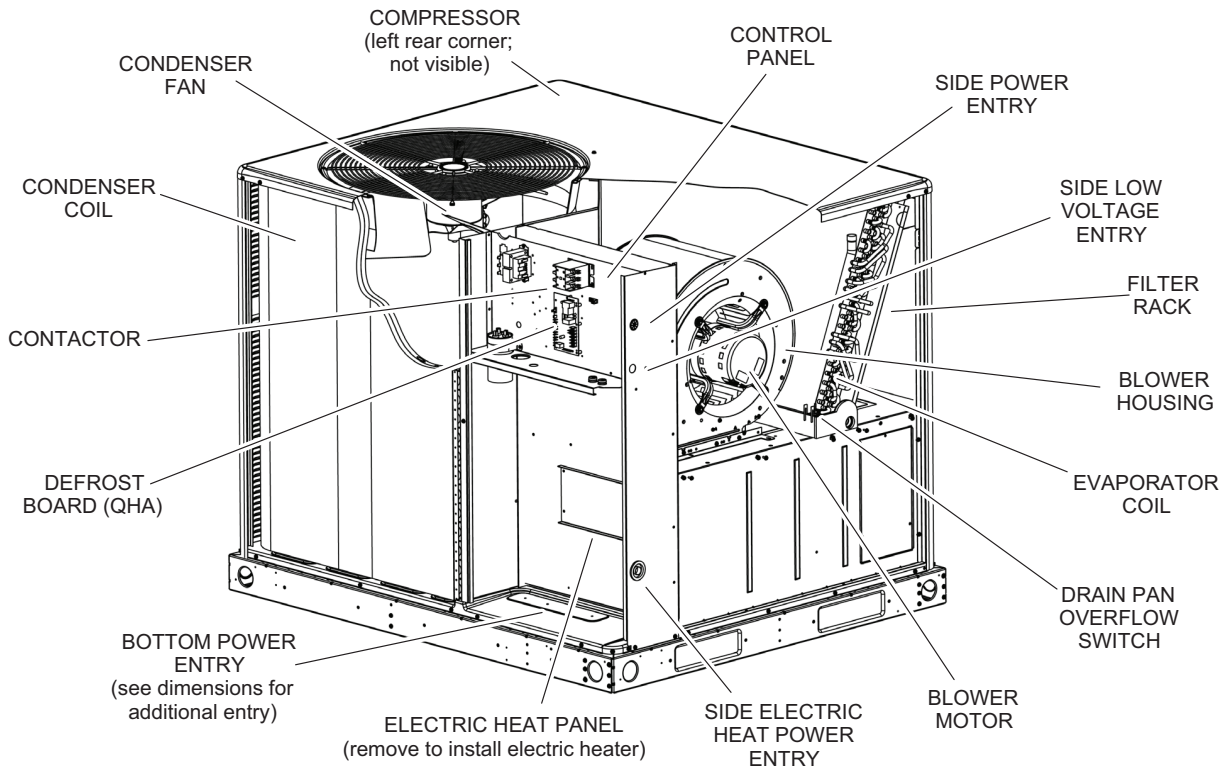

## Shipping and Packing List

### Package 1 of 1 contains:

1 - Assembled unit

Check unit for shipping damage. Receiving party should contact last carrier immediately if shipping damage is found.

## General

These instructions are intended as a general guide and do not supersede local codes in any way. Authorities having jurisdiction should be consulted before installation.

## Requirements

See FIGURE 1 for unit clearances.

## ⚠ NOTICE

### Roof Damage!

This system contains both refrigerant and oil. Some rubber roofing material may absorb oil, causing the rubber to swell. Bubbles in the rubber roofing material can cause leaks. Protect the roof surface to avoid exposure to refrigerant and oil during service and installation. Failure to follow this notice could result in damage to roof surface.

## ⚠ WARNING



Electric shock hazard and danger of explosion. Can cause injury, death or product or property damage. Turn off gas and electrical power to unit before performing any maintenance or servicing operations on the unit. Follow lighting instructions attached to unit when putting unit back into operation and after service or maintenance.



## ⚠ IMPORTANT

The Clean Air Act of 1990 bans the intentional venting of refrigerant (CFC's and HCFC's) as of July 1, 1992. Approved methods of recovery, recycling or reclaiming must be followed. Fines and/or incarceration may be levied for non-compliance.

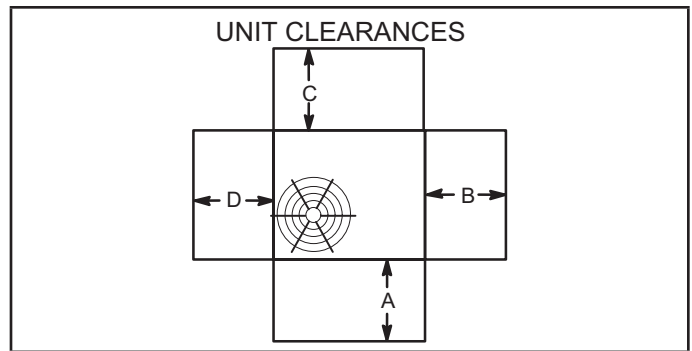

FIGURE 1

<sup>1</sup> Unit Clearance	A in.	B in.	C in.	D in.	Top Clearance
Service Clearance	24	24	0	24	48

NOTE - Entire perimeter of unit base requires support when elevated above mounting surface.

<sup>1</sup> **Service Clearance** - Required for removal of serviceable parts.

Minimum Operation Clearance - Required clearance for proper unit operation. Location

- 1 - Unit is designed for outdoor installation only. Unit must be installed so all electrical components are protected from water.
- 2 - Condenser coils must have an unlimited supply of air.
- 3 - For ground level installation, use a level prefabricated pad or use a level concrete slab. Do not tie the slab to the building foundation.
- 4 - Maintain level within a tolerance of 1/4" maximum across the entire length or width of the unit.

## ⚠ CAUTION

Unit levelness is critical for proper float switch operation.

Use of this unit as a construction heater or air conditioner is not recommended during any phase of construction. Very low return air temperatures, harmful vapors and operation of the unit with clogged or misplaced filters will damage the unit.

If this unit has been used for heating or cooling of buildings or structures under construction, the following conditions must be met or the warranty will be void:

- A room thermostat must control the unit. The use of fixed jumpers that will provide continuous heating or cooling is not allowed.
- A pre-filter must be installed at the entry to the return air duct.
- The return air duct must be provided and sealed to the unit.
- Return air temperature range between 55°F (13°C) and 80°F (27°C) must be maintained.
- Air filters must be replaced and pre-filters must be removed upon construction completion.

- The components, duct system, air filters and evaporator coil must be thoroughly cleaned following final construction clean-up.
- The unit operating conditions (including airflow and cooling operation) must be verified according to these installation instructions.

## UNIT SUPPORT

In the U.S., units may be installed on combustible floors made from wood or class A, B, or C roof covering material.

In Canada, units may be installed on combustible floors.

*NOTE - Securely fasten roof curb to roof per local codes.*

## CAUTION

To reduce the likelihood of supply / return air bypass and promote a proper seal with the rooftop unit, duct work / duct drops / diffuser assemblies must be supported independently to the building structure.

### A - Downflow Discharge Application

#### Roof Mounting with ACURB85

- 1 - The ACURB85 roof mounting curb must be installed, flashed and sealed in accordance with the instructions provided with the curb.
- 2 - The ACURB85 roof mounting curb should be square and level to 1/16" per linear foot (5mm per linear meter) in any direction.
- 3 - Duct must be attached to the roof mounting curb and not to the unit; supply and return plenums must be installed before setting the unit.
- 4 - Prior to setting the unit on the roof curb, remove the shipping bracket located underneath the unit. Remove the two screws in the base rail (located on the front and rear of the unit). The four screws and the bracket can be discarded. See FIGURE 2.
- 5 - Be sure that all required clearances are observed (see Clearances section).

### Installer's Roof Mounting Curb

Many types of roof curbs can be used to install the unit depending upon different roof structures. Items to keep in mind when using the building curb or supports are:

- 1 - The base is fully enclosed and not insulated, so an enclosed, insulated curb is required.
- 2 - The curbs or supports must be constructed with non-combustible materials and should be square and level to 1/16" per linear foot (5mm per linear meter) in any direction.
- 3 - Curb or supports must be high enough to prevent any form of moisture from entering unit. Recommended minimum curb height is 14" (356mm).
- 4 - Duct must be attached to the roof mounting curb and not to the unit. Supply and return plenums must be installed before setting the unit.
- 5 - Units require support along all four sides of unit base. Supports must be constructed of steel or suitably treated wood materials.

### B - Horizontal Discharge Applications

- 1 - Specified installation clearances must be maintained when installing units. Refer to FIGURE 1.
- 2 - Top of support slab should be approximately 4" (102mm) above the finished grade and located so no run-off water from higher ground can collect around the unit.
- 3 - Units require support along all four sides of unit base. Supports must be constructed of steel or suitably treated wood materials.

## DUCT CONNECTION

All exterior ducts, joints and openings in roof or building walls must be insulated and weather-proofed with flashing and sealing compounds in accordance with applicable codes. Any duct passing through an unconditioned space must be insulated.

The duct system should be designed and sized according to the methods in the Air Conditioning Contractors of America (ACCA) manual that is most appropriate to the installation application.

A closed return air duct system shall be used. This shall not preclude use of economizers or outdoor fresh air intake.

It is recommended that supply and return air duct connections at the unit be made with flexible joints. The supply and return air duct systems should be designed for the CFM and static requirements of the job. They should not be sized by matching the dimensions of the duct connections on the unit. The unit is shipped capable of either horizontal flow (side duct connections) or down flow (bottom duct connections). Duct attachment screws are intended to go into the duct panel. Duct to unit connections must be sealed and weather-proofed.

## CAUTION

In downflow applications, do not drill or punch holes in base of unit. Leaking in roof may occur if unit base is punctured.

### Rigging Unit For Lifting

Rig unit for lifting by attaching four cables to holes in unit base rail. See FIGURE 2.

Exercise care when moving the unit. Do not remove any packaging until the unit is near the place of installation.

- 1 - Connect rigging to the unit base rails using both holes in each corner.
- 2 - All panels must be in place for rigging.
- 3 - Place field-provided spreaders in place. Spreaders must be of adequate strength and length (must exceed unit dimension by 6 inches). Units may also be moved or lifted with a forklift. **The lengths of the forks of the forklift must be a minimum of 42 inches.**

*CAUTION - Before lifting a unit, make sure that the weight is distributed equally on the cables so that it will lift evenly.*

### Unpacking

Locate the four stacking brackets at each corner of the top panel. Remove the screws that secure these brackets. All screws must be re-installed. The stacking brackets can be discarded. Remove the bag and remaining packaging material, which can be discarded. Locate the four plastic fork slot bumpers on the base rails. Remove the fasteners and bumpers and discard.

### Downflow Air Discharge

Unit is shipped with panels covering the horizontal and downflow supply and return air openings (four covers).

- 1 - Before setting the unit on a roof curb, see "Roof Mounting" section for instructions on removing the shipping bracket underneath the unit.
- 2 - Remove and retain the horizontal supply and return duct covers.
- 3 - Remove the four screws securing the downflow duct covers inside the unit. Remove and discard the covers.
- 4 - Remove screws located between the supply and return air openings that attach the blower deck to the base, and discard these screws. These screws can interfere with bottom duct connections or roof curb seals.
- 5 - Install the duct system onto the unit.
- 6 - Replace the retained horizontal supply and return duct covers.

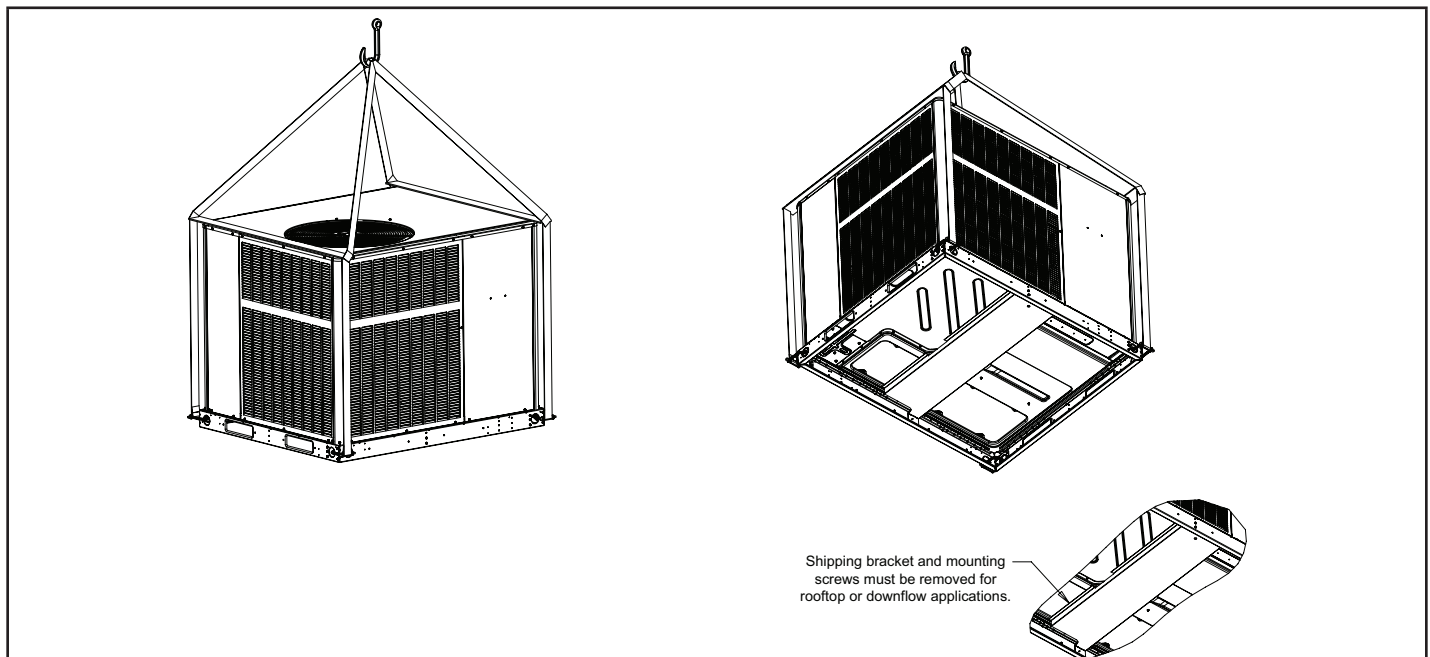

FIGURE 2

### Field-Installed Economizer (Downflow)

- 1 - Before setting the unit on a roof curb, see "Roof Mounting" section for instructions on removing the shipping bracket underneath the unit.
- 2 - Remove the horizontal supply and return duct covers.
- 3 - Remove the four screws securing the downflow duct covers inside the unit. Remove and discard the covers.
- 4 - Remove the screws securing the bottom covers, and discard the bottom covers (supply and return).
- 5 - Remove screws located between the supply and return air openings that attach the blower deck to the base, and discard these screws. These screws can interfere with bottom duct connections or roof curb seals.
- 6 - Remove the close-out panel from the left-hand side of the return duct opening.
- 7 - Remove the return air panel above the return duct opening.
- 8 - Install the economizer into the unit rear panel. Wire and set up following the instructions that accompany the economizer.
- 9 - Return air duct must be field-supported.
- 10 - Unused covers and panels can be discarded.

- 5 - Install the economizer into the unit rear panel. Wire and set up following the instructions that accompany the economizer.
- 6 - Install return air duct to the economizer at the former location of the relief hood.
- 7 - Cut a 20" wide X 14" high opening in the return air duct and install the economizer relief hood. See FIGURE 4.
- 8 - Return air duct must be field-supported.
- 9 - Unused covers and panels can be discarded.

### Horizontal Air Discharge

Unit is shipped with panels covering the horizontal and downflow supply and return air openings. See FIGURE 3.

#### Field-Installed Economizer (Horizontal)

- 1 - Remove the horizontal duct covers over the supply and return duct openings. Covers can be discarded.

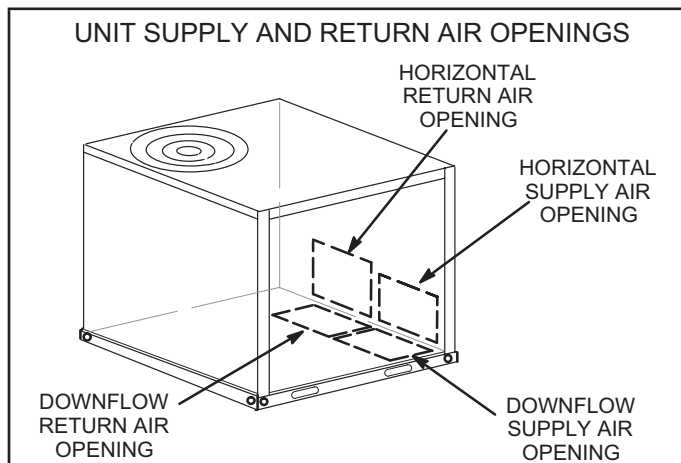

FIGURE 3

- 2 - Remove the close-out panel from the left-hand side of the return duct opening.
- 3 - Remove the return air panel above the return duct opening.
- 4 - Remove the lower (relief) hood from the economizer.

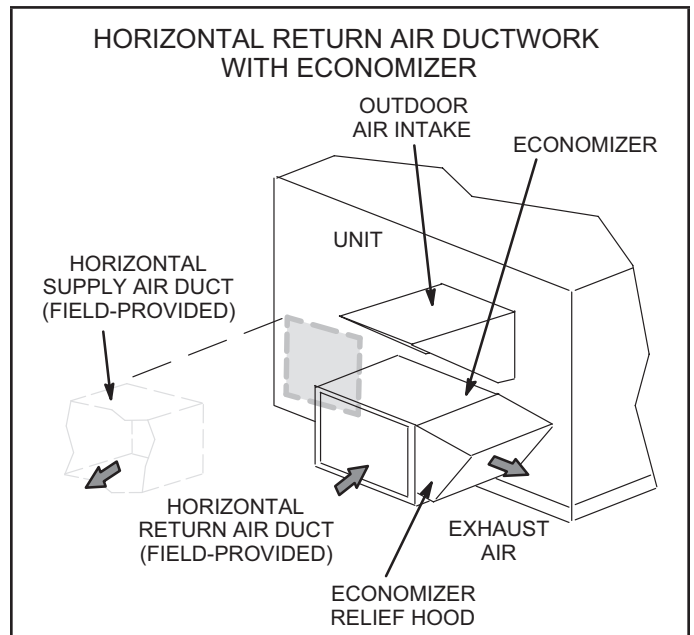

FIGURE 4

### Condensate Drains

This package unit is equipped with a 3/4" FPT coupling for condensate line connection. Plumbing must conform to local codes. Use a sealing compound on male pipe threads.

**Do not** operate unit without a drain trap. The condensate drain is on the negative pressure side of the blower; therefore, air being pulled through the condensate line will prevent positive drainage without a proper trap. **The condensate drain line must be properly trapped, routed to a suitable drain and primed prior to unit commissioning.**

*NOTE - Install drain lines and trap so they do not block service access to the unit.*

See FIGURE 5 for proper drain arrangement. The drain line must pitch to an open drain or pump to prevent clogging of the line. Seal around the drain connection with suitable material to prevent air leakage into the return air system.

To prime trap, pour several quarts of water into drain, enough to fill drain trap and line.

*CAUTION - Drain lines should be hand-tightened only. Do not use tools to tighten fitting into drain.*

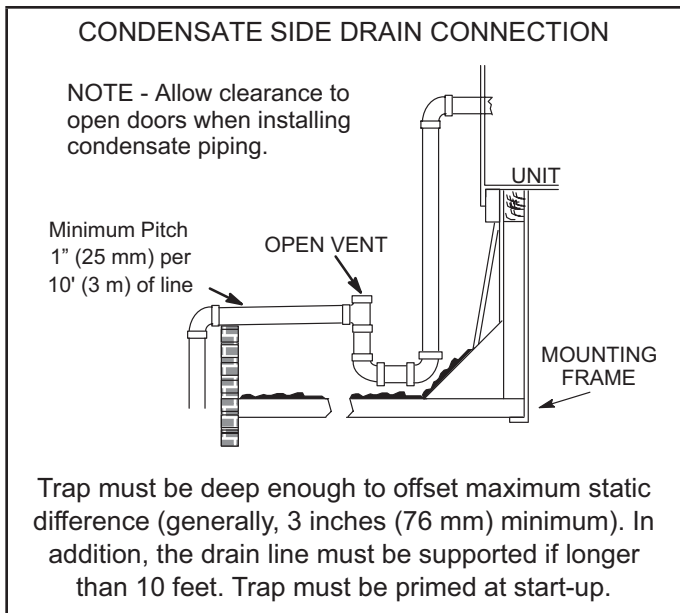

**FIGURE 5**

## Electrical Connections

All wiring should be done in accordance with the National Electrical Code, ANSI/NFPA No. 70 (latest edition); Canadian Electrical Code Part 1, CSA C22.1 (latest edition); or local codes where they prevail. Use wiring with a temperature limitation of 75°C minimum. Run the 208, 230, or 460 volt, 60 hertz electric power supply through a fused disconnect switch to the control box of the unit and connect as shown in the wiring diagram located on the inside of the control access panel.

Power supply to the unit must be N.E.C. Class 1, and must comply with all applicable codes. A disconnect switch should be field provided for the unit; follow local codes to determine what type of switch to use. The switch must be separate from all other circuits. If any of the wire supplied with the unit must be replaced, replacement wire must be of the type shown on the wiring diagram. Electrical wiring must be sized to carry minimum circuit ampacity marked on the unit. Use copper conductors only. Each unit must be wired with a separate branch circuit and be properly fused.

An optional bottom-entry power kit is available for these units. See the instructions in that kit for proper installation details.

### THERMOSTAT WIRING

#### A - Thermostat Location

Room thermostat mounts vertically on a standard 2" X 4" handy box or on any non-conductive flat surface.

Locate thermostat approximately 5 feet (1524mm) above the floor in an area with good air circulation at average temperature. Avoid locating the room thermostat where it might be affected by:

- Drafts or dead spots behind doors and in corners
- Hot or cold air from ducts
- Radiant heat from sun or appliances

- Concealed pipes and chimneys

#### B - Control Wiring

- 1 - Route thermostat cable or wires from subbase to control panel (refer to unit dimensions to locate bottom and side power entry).

**IMPORTANT - Unless field thermostat wires are rated for maximum unit voltage, they must be routed away from line voltage wiring.**

Use 18 AWG wire for all applications using remotely installed thermostats.

- 2 - Install thermostat assembly in accordance with instructions provided with thermostat.
- 3 - Connect thermostat wiring to leads in control panel. Wire as shown in FIGURE 6.
- 4 - Four wires are required for cooling.
- 5 - A thermostat capable of two-stage cooling is required when economizers are installed.

#### C - Heat Anticipator

The heat anticipator setting is 0.75 amp. It is important that the anticipator setpoint be correct. Too high of a setting will result in longer heat cycles and a greater temperature swing in the conditioned space. Reducing the value below the correct setpoint will give shorter "ON" cycles and may result in the lowering of the temperature within the conditioned space.

**IMPORTANT - Terminal connections at the wall plate or subbase must be made securely. Loose control wire connections may allow unit to operate but not with proper response to room demand.**

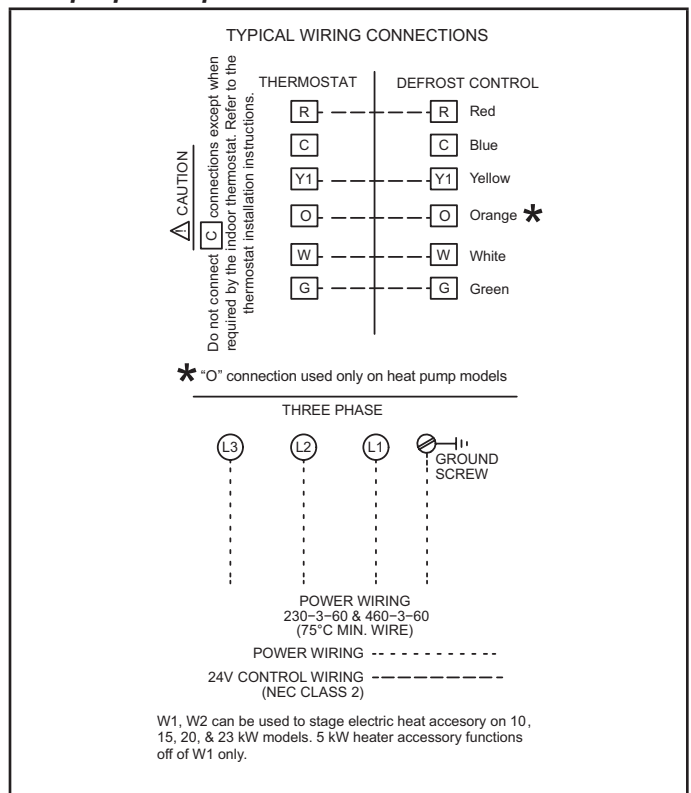

**FIGURE 6**

## Blower Operation and Adjustments

Units are equipped with direct drive blowers.

### IMPORTANT

Three phase scroll compressors must be phased sequentially for correct compressor and blower rotation. Follow "COOLING START-UP" section of installation instructions to ensure proper compressor and blower operation.

Initiate blower demand at thermostat according to instructions provided with thermostat. Unit will cycle on thermostat demand. The following steps apply to applications using a typical thermostat.

- 1 - Blower operation is manually set at the thermostat subbase fan switch. With fan switch in **ON** position, blowers will operate continuously.
- 2 - With fan switch in **AUTO** position, the blowers will cycle with demand. Blowers and entire unit will be off when system switch is in **OFF** position.

## BLOWER PERFORMANCE

### QCA/QHA036S4D

Blower Tap	External Static (in.w.g.)										
		0.1	0.2	0.3	0.4	0.5	0.6	0.7	0.8	0.9	1.0
Tap 1 (Fan Only)	CFM	839	756	658	531	446	366	---	---	---	---
	RPM	431	481	540	606	655	702	---	---	---	---
	Watts	66	72	78	86	91	97	---	---	---	---
Tap 2 (Low Cooling)	CFM	1241	1204	1157	1109	1067	1024	978	931	885	848
	RPM	762	784	809	836	862	891	919	947	973	999
	Watts	261	268	276	283	290	299	307	314	322	329
Tap 3 (High Cooling)	CFM	1547	1508	1477	1440	1398	1364	1332	1291	1260	1220
	RPM	917	940	958	978	999	1018	1040	1063	1085	1106
	Watts	475	484	493	501	511	519	529	538	549	554
<sup>1</sup> Tap 4 (Low Electric Heat)	CFM	1241	1204	1157	1109	1067	1024	978	931	885	848
	RPM	762	784	809	836	862	891	919	947	973	999
	Watts	261	268	276	283	290	299	307	314	322	329
<sup>1</sup> Tap 5 (High Electric Heat)	CFM	1547	1508	1477	1440	1398	1364	1332	1291	1260	1220
	RPM	917	940	958	978	999	1018	1040	1063	1085	1106
	Watts	475	484	493	501	511	519	529	538	549	554

NOTE - All air data is measured external to unit with dry coil and without air filters.

<sup>1</sup> Taps 4 and 5 are used with Optional Electric Heat. Refer to Electric Heat nameplate for proper heat tap selection.



**QCA/QHA042S4D**

Blower Tap	External Static (in.w.g.)										
		0.1	0.2	0.3	0.4	0.5	0.6	0.7	0.8	0.9	1.0
Tap 1 (Fan Only)	CFM	833	758	676	569	493	406	346	---	---	---
	RPM	441	493	547	605	659	708	745	---	---	---
	Watts	67	73	79	87	92	99	103	---	---	---
Tap 2 (Low Cooling)	CFM	1575	1519	1475	1438	1411	1376	1341	1294	1252	1209
	RPM	777	805	832	857	882	908	937	968	995	1024
	Watts	370	382	394	405	416	428	440	454	467	478
Tap 3 (High Cooling)	CFM	1818	1772	1726	1680	1638	1599	1562	1518	1475	1429
	RPM	751	780	806	833	861	884	907	931	962	988
	Watts	396	410	420	433	445	455	465	476	489	500
<sup>1</sup> Tap 4 (Low Electric Heat)	CFM	1575	1519	1475	1438	1411	1376	1341	1294	1252	1209
	RPM	777	805	832	857	882	908	937	968	995	1024
	Watts	370	382	394	405	416	428	440	454	467	478
<sup>1</sup> Tap 5 (High Electric Heat)	CFM	1818	1772	1726	1680	1638	1599	1562	1518	1475	1429
	RPM	751	780	806	833	861	884	907	931	962	988
	Watts	396	410	420	433	445	455	465	476	489	500

NOTE - All air data is measured external to unit with dry coil and without air filters.

<sup>1</sup> Taps 4 and 5 are used with Optional Electric Heat. Refer to Electric Heat nameplate for proper heat tap selection.

**QCA/QHA048S4D**

Blower Tap	External Static (in.w.g.)										
		0.1	0.2	0.3	0.4	0.5	0.6	0.7	0.8	0.9	1.0
Tap 1 (Fan Only)	CFM	839	757	658	532	447	366	---	---	---	---
	RPM	431	481	540	606	655	702	---	---	---	---
	Watts	66	72	78	86	91	97	---	---	---	---
Tap 2 (Low Cooling)	CFM	1677	1624	1577	1526	1481	1432	1385	1336	1279	1226
	RPM	698	729	759	789	816	843	872	902	934	968
	Watts	335	347	359	370	380	390	401	412	425	438
Tap 3 (High Cooling)	CFM	1972	1931	1885	1840	1803	1758	1725	1685	1644	1602
	RPM	797	823	853	880	903	929	951	974	997	1024
	Watts	532	545	560	575	587	601	613	623	634	648
<sup>1</sup> Tap 4 (Low Electric Heat)	CFM	1677	1624	1577	1526	1481	1432	1385	1336	1279	1226
	RPM	698	729	759	789	816	843	872	902	934	968
	Watts	335	347	359	370	380	390	401	412	425	438
<sup>1</sup> Tap 5 (High Electric Heat)	CFM	1972	1931	1885	1840	1803	1758	1725	1685	1644	1602
	RPM	797	823	853	880	903	929	951	974	997	1024
	Watts	532	545	560	575	587	601	613	623	634	648

NOTE - All air data is measured external to unit with dry coil and without air filters.

<sup>1</sup> Taps 4 and 5 are used with Optional Electric Heat. Refer to Electric Heat nameplate for proper heat tap selection.

**QCA/QHA060S4D**

Blower Tap	External Static (in.w.g.)										
		0.1	0.2	0.3	0.4	0.5	0.6	0.7	0.8	0.9	1.0
Tap 1 (Fan Only)	CFM	1378	1320	1269	1223	1160	1099	1030	965	899	833
	RPM	603	639	668	699	740	778	816	855	894	931
	Watts	181	191	197	205	214	224	233	242	251	261
Tap 2 (Low Cooling)	CFM	1980	1936	1893	1852	1816	1780	1740	1703	1660	1615
	RPM	806	833	862	887	903	927	951	971	1002	1029
	Watts	460	472	484	498	504	516	526	536	551	564
Tap 3 (High Cooling)	CFM	2340	2300	2259	2224	2187	2158	2139	2108	2079	2038
	RPM	931	958	981	1004	1027	1047	1063	1081	1099	1116
	Watts	742	760	775	790	805	820	829	841	852	858
<sup>1</sup> Tap 4 (Low Electric Heat)	CFM	2232	2194	2154	2129	2089	2057	2026	1991	1960	1926
	RPM	897	917	946	970	993	1012	1028	1048	1068	1089
	Watts	653	666	683	696	708	722	731	743	755	767
<sup>1</sup> Tap 5 (High Electric Heat)	CFM	2329	2291	2256	2220	2183	2153	2136	2102	2075	2035
	RPM	931	954	980	1000	1025	1044	1061	1081	1102	1116
	Watts	742	757	773	785	804	815	828	841	855	858

NOTE - All air data is measured external to unit with dry coil and without air filters.

<sup>1</sup> Taps 4 and 5 are used with Optional Electric Heat. Refer to Electric Heat nameplate for proper heat tap selection.

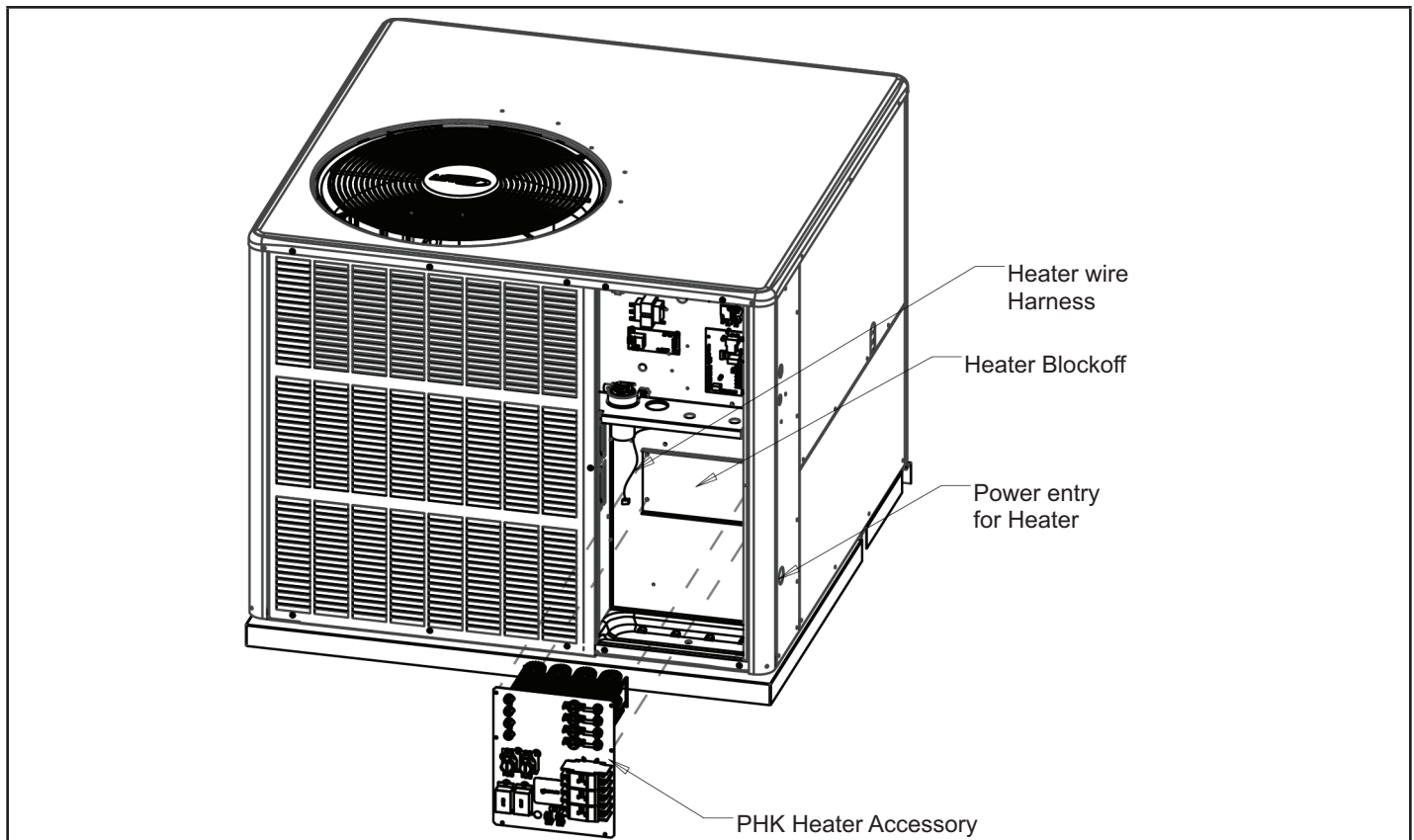

FIGURE 7

### Heater Kit Accessory (if used)

This unit is fully equipped for cooling operation without auxiliary heat. A heater kit accessory may also be used. Install the heater kit as follows. See FIGURE 7.

- 1 - Disconnect the power and open the main control access.
- 2 - Disconnect the plug separating the high voltage wire harness. Remove the high voltage wire harness plug and discard.
- 3 - Remove the four screws holding the heater block-off in place and remove block-off.
- 4 - Insert the heater into the control panel and fasten using the same mounting holes.
- 5 - Plug the heater wiring harness into the wire harness on the control assembly. Field wiring of the auxiliary heater is separate from the unit power supply. Wire the power supply wiring for the heater to the appropriate connections on the heater kit.

### Start-Up

#### A - Operation

##### Cooling

- When the thermostat is in the cooling mode, the O circuit is powered, which energizes the reversing valve.
- Upon cooling demand, the thermostat closes circuit R and Y.
- Closing R and Y closes the unit contactor, starting the compressor and outdoor fan.
- The thermostat automatically closes the R to G circuit, which brings on the indoor blower at the same time.
- Upon satisfying cooling demand, the thermostat will open the above circuits and open the main contactor, stopping the compressor and outdoor fan.
- If the unit is equipped with a delay timer, the blower will continue to operate for 60 to 90 seconds, which improves system efficiency.

### Heating - Heat Pump Stage

- Upon heating demand, the thermostat closes circuit R to Y, which closes the unit contactor, starting the compressor and outdoor fan.
- The reversing valve is not energized in the heating mode.
- The thermostat again automatically brings on the indoor fan at the same time.
- Upon satisfying heating demand, the thermostat opens above circuits and stops unit operation.

### Heating - Heat Pump Stage

- Upon heating demand for auxiliary electric heat, the thermostat closes circuit R to W, which energizes the heater sequencers as well as the indoor blower.
- Upon satisfying auxiliary heat demand, the thermostat opens above circuits and heating elements sequence off; blower continues to operate until all heating elements have turned off.

## B - Defrost System

The defrost system includes two components: the defrost thermostat and the defrost control.

### Defrost Thermostat

The defrost thermostat is located on the evaporator coil. When the defrost thermostat senses 35°F or cooler, the thermostat contacts close and send a signal to the defrost control board to start the defrost timing. It also terminates defrost when the liquid line warms up to 60°F.

### Defrost Control

The defrost control board includes the combined functions of time/temperature defrost control, defrost relay, diagnostic LEDs and terminal strip for field wiring connections. See FIGURE 8.

The control provides automatic switching from normal heating operation to defrost mode and back. During the compressor cycle (call for defrost), the control accumulates compressor run time at 30, 60, 90 minute field-adjustable intervals. If the defrost thermostat is closed when the selected compressor run time interval ends, the defrost relay is energized and the defrost begins.

- 1 - An on-board outdoor ambient temperature sensor on the defrost control bypasses the low pressure switch during low ambient temperature below 15°F in heating mode to eliminate nuisance low pressure trips.

*NOTE - 15°F is an approximate temperature, depending upon model and installation location.*

- 2 - A defrost cycle will initiate when there has been a low pressure switch trip; the defrost sensor must be closed and the defrost time interval must not have expired.
- 3 - At the end of the defrost cycle, when the unit goes back to heating mode, the low pressure switch is checked to see if it has reset. If so, the strikeout is not counted. This prevents lockout during extreme winter conditions.

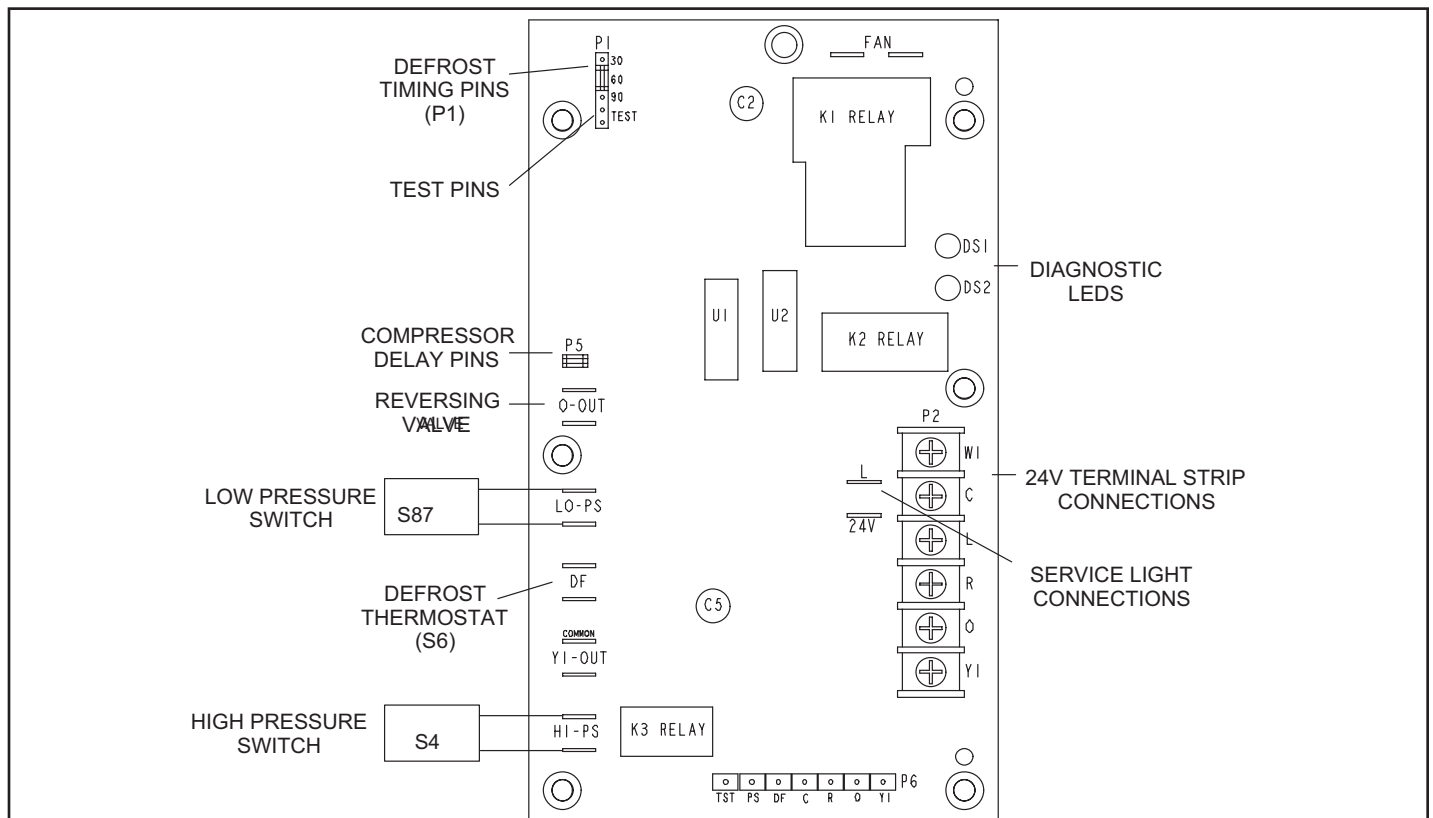

**FIGURE 8**

### Defrost Control Timing Pins

Each timing pin selection provides a different accumulated compressor run time period during one thermostat run cycle. This time period must occur before a defrost cycle is initiated. The defrost interval can be adjusted to 30 (T1), 60 (T2), or 90 (T3) minutes. It is intended that this **product should be set at the 60-minute time interval** at initial installation. If the timing selector jumper is not in place, the control defaults to a 90-minute defrost interval. The maximum defrost period is 14 minutes and cannot be adjusted.

*NOTE - For geographic areas that experience low temperature and high humidity conditions (below 35°F and above 80% RH), the defrost timer pin must be field set at installation to a 60 or 30 minute defrost interval to ensure reliable system operation while in heating mode.*

A test option is provided for troubleshooting. The test mode may be started any time the unit is in the heating mode and the defrost thermostat is closed or jumpered. If the jumper is in the TEST position at power up, the control will ignore the test pins. When the jumper is placed across the TEST pins for 2 seconds, the control will enter the defrost mode. If the jumper is removed before an additional 5-second period has elapsed (7 seconds total), the unit will remain in defrost mode until the defrost thermostat opens or 14 minutes have passed. If the jumper is not removed until after the additional 5-second period has elapsed, the defrost will terminate and the test option will not function again until the jumper is removed and reapplied.

#### Compressor Delay (Quiet Shift)

The defrost board has a field-selectable function to reduce occasional sounds that may occur while the unit is cycling in and out of the defrost mode. The compressor will be cycled off for 30 seconds going in and out of the defrost mode when the compressor delay jumper is removed.

*NOTE: The 30-second "off" cycle is not functional when jumpering the TEST pins.*

#### Time Delay

The defrost control includes a compressor timer, which ensures the compressor is off for a minimum amount of time between operating cycles.

The timed-off delay is 5 minutes long. The delay helps to protect the compressor from short cycling in case the power to the unit is interrupted or a pressure switch opens.

The delay is bypassed by placing the timer select jumper across the TEST pins for 0.5 seconds.

### Pressure Switch Circuit

High and low pressure switches are connected to the defrost control board on heat pump models. Air conditioning models have a high pressure switch installed in line with compressor contactor coil. See FIGURE 8.

**During a single demand cycle, the defrost control will lock out the unit after the fifth time that the circuit is interrupted by any pressure switch wired to the control board. In addition, the diagnostic LEDs will indicate a locked-out pressure switch after the fifth occurrence of an open pressure switch. See TABLE 1.**

**The unit will remain locked out until power to the board is interrupted, then re-established, or until the jumper is applied to the TEST pins for 0.5 seconds.**

*NOTE: The defrost control board ignores input from the low pressure switch terminals as follows:*

- During the TEST mode
- During the defrost cycle
- During the 90-second start-up period
- For the first 90 seconds each time the reversing valve switches heat/cool modes

**If the TEST pins are jumpered and the 5-minute delay is being bypassed, the LO PS terminal signal is not ignored during the 90-second start-up period.**

#### Diagnostic LEDs

The defrost board uses two LEDs for diagnostics. The LEDs flash a specific sequence according to the condition as shown in TABLE 1.

**TABLE 1**

Defrost Board Diagnostic LEDs		
Green LED (DS2)	Red LED (DS1)	Condition
OFF	OFF	No Power to Control
Simultaneous Slow FLASH		Normal Operation / Power to Control
Alternating Slow FLASH		5-min Anti-Short Cycle Delay
ON	Slow FLASH	Low Pressure Switch Ignored (Low Ambient)
Fault and Lockout Codes		
OFF	Slow FLASH	Low Pressure Switch Fault
OFF	ON	Low Pressure Switch Lockout
Slow FLASH	OFF	High Pressure Switch Fault
ON	OFF	High Pressure Switch Lockout

### C - Three-Phase Scroll Compressor Voltage Phasing

Three phase scroll compressors must be phased sequentially to ensure correct compressor and blower rotation and operation. Compressor and blower are wired in phase at the factory. Power wires are color-coded as follows: line 1-red, line 2-yellow, line 3-blue.

- 1 - Observe suction and discharge pressures and blower rotation on unit start-up.
- 2 - Suction pressure must drop, discharge pressure must rise and blower rotation must match rotation marking.

If pressure differential is not observed or blower rotation is not correct:

- 3 - Disconnect all remote electrical power supplies.
- 4 - Reverse any two field-installed wires connected to the line side of contactor.
- 5 - Make sure the connections are tight.

Discharge and suction pressures should operate at their normal start-up ranges.

### D - Refrigerant Charge and Check

**WARNING-Do not exceed nameplate charge under any condition.**

This equipment is a self-contained, factory-optimized refrigerant system. The unit should not require adjustments to system charge when properly installed. If unit performance is questioned, perform the following checks.

Ensure unit is installed per manufacturers instructions and that line voltage and air flow are correct. Refer to TABLE 2 for proper performance value. The indoor metering device varies by model. When checking performance of a unit using an orifice for metering, refer to the suction superheat value to judge performance. When checking performance of a unit that uses an expansion valve for metering, refer to the subcooling value to judge system performance.

If the measured performance value varies from table value allowance, check internal seals, service panels and duct work for air leaks, as well as restrictions and blower speed settings. If unit performance remains questionable, remove system charge, evacuate to 500 microns, and weigh in refrigerant to nameplate charge. It is critical that the exact charge is re-installed. Failure to comply will compromise system performance.

If unit performance is still questionable, check for refrigerant-related problems, such as blocked coil or circuits, malfunctioning metering device or other system components.

**TABLE 2**

#### A/C COOLING SYSTEM PERFORMANCE VALUES

Model	Suction Superheat +/- 3	Liquid Subcooling +/- 2
3 Ton	14	
3.5 Ton	14	
4 Ton	16	
5 Ton	17	

Based on outdoor ambient temperature of 82°F and indoor entering air of 80°F db / 6°F wb.

**TABLE 3**

#### HP COOLING SYSTEM PERFORMANCE VALUES

Model	Suction Superheat +/- 3	Liquid Subcooling +/- 2
3 Ton	16	
3.5 Ton	22	
4 Ton	22	
5 Ton		5

Based on outdoor ambient temperature of 82°F and indoor entering air of 80°F db / 6°F wb.

**TABLE 4**

#### HP HEATING SYSTEM PERFORMANCE VALUES

Model	Suction Superheat +/- 3
3 Ton	28
3.5 Ton	20
4 Ton	35
5 Ton	28

Based on outdoor ambient temperature of 82°F and indoor entering air of 80°F db / 6°F wb.

### E - Compressor Controls

See unit wiring diagram to determine which controls are used on each unit. Optional controls are identified on wiring diagrams by arrows at junction points.

#### 1 - High Pressure Switch (S4)

The high pressure switch is an auto-reset SPST N.C. switch which opens on a pressure rise.

S4 is located in the compressor discharge line and is wired in series with the compressor contactor coil.

When discharge pressure rises to 590±10 psig (4068+69kPa), indicating a problem with the system, the switch opens. The respective compressor is de-energized but the economizer can continue to operate. Auto-reset switches close at 418±20psig (2882±138kPa).

#### 2 - Compressor High Temperature Limit (S173)

The temperature limit switch S5 is located on the top of Interlink compressors and is wired in series with the high pressure switch S4.

**TABLE 5**  
**AC COOLING PERFORMANCE**

80°F DB / 67°F WB Return Air		Air Temperature Entering Outdoor Coil, °F											
Cooling Input (1000 BTU)	Pressure	65	70	75	80	82	85	90	95	100	105	110	115
36	Suction	135	137	140	142	143	144	147	149	151	152	154	155
42		129	132	135	139	140	141	143	145	146	147	148	149
48		132	136	139	143	144	145	146	147	149	151	152	154
60		130	131	133	134	135	136	139	141	144	146	149	152
36	Liquid	250	275	301	326	336	351	375	399	423	446	470	493
42		248	271	293	316	325	339	362	385	411	436	462	487
48		265	286	308	329	338	352	376	400	427	455	482	509
60		256	276	296	316	324	340	365	386	415	438	473	503

**TABLE 6**  
**HP COOLING PERFORMANCE**

80°F DB / 67°F WB Return Air		Air Temperature Entering Outdoor Coil, °F											
Cooling Input (1000 BTU)	Pressure	65	70	75	80	82	85	90	95	100	105	110	115
36	Suction	136	138	140	142	143	144	145	147	149	151	152	154
42		127	131	134	138	139	141	144	147	147	148	148	148
48		132	135	138	142	143	144	147	149	151	152	154	155
60		133	134	135	136	136	137	138	140	142	146	149	146
36	Liquid	267	285	303	322	329	343	367	391	417	443	468	494
42		238	259	280	302	310	324	348	371	396	421	445	470
48		248	271	294	317	326	340	363	386	412	438	464	490
60		245	276	296	316	312	340	365	373	415	438	473	479

**TABLE 7**  
**HP HEATING PERFORMANCE**

80°F DB / 67°F WB Return Air		Air Temperature Entering Outdoor Coil, °F											
Cooling Input (1000 BTU)	Pressure	0	5	10	17	20	25	36	40	47	50	55	60
36	Suction	35	42	49	58	62	69	82	89	98	102	109	115
42		25	33	42	54	59	68	85	94	106	111	120	129
48		32	39	47	57	62	69	84	92	102	107	114	122
60		30	37	44	54	58	65	80	87	97	101	108	116
36	Liquid	251	258	265	275	279	286	300	307	317	321	328	335
42		297	300	304	309	311	315	322	326	331	333	337	341
48		289	297	306	318	323	332	349	358	370	375	384	393
60		272	281	290	302	307	316	334	343	355	360	369	378

## Service

The unit should be inspected once a year by a qualified service technician.

## ⚠ CAUTION

Label all wires prior to disconnection when servicing controls. Wiring errors can cause improper and dangerous operation. Verify proper operation after servicing.

### A - Filters

Air filters are not supplied with the unit. A field-provided air filter must always be installed ahead of the evaporator coil and must be cleaned or replaced if necessary. Dirty filters will reduce the airflow of the unit. All units are equipped with a factory-installed filter rack. Use two 20 X 20 X 1" (508 X 508 X 51mm) filters. Refer to local codes or appropriate jurisdiction for approved filters.

To change filters, remove the blower access panel and slide the filters out of the internal rack. See FIGURE 9.

Approved filters should be checked monthly and replaced when necessary. Take note of air flow direction marking on filter frame when reinstalling filters.

**NOTE - Filters must be U.L.C. certified or equivalent for use in Canada.**

An optional tool-less filter access kit is available. The kit includes two new blower panels (one smaller panel secured with screws, the other with twist latches) to provide access for filter changes without any hand tools.

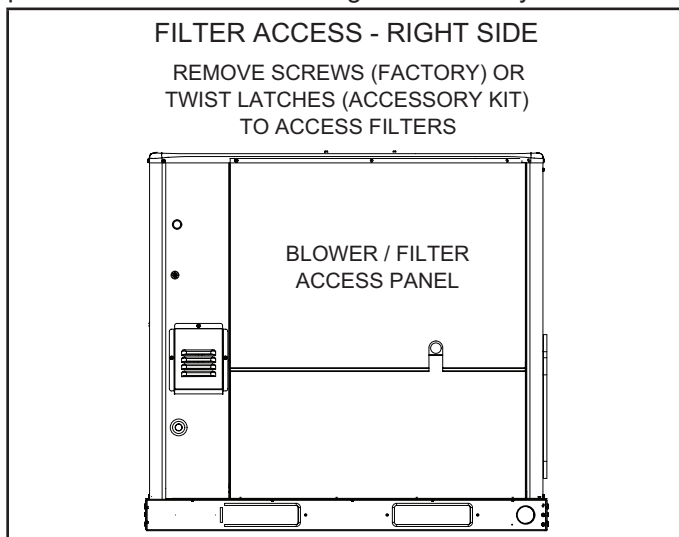

FIGURE 9

### B - Lubrication

All motors are lubricated at the factory. No further lubrication is required.

### C - Evaporator Coil

Inspect and clean coil at beginning of each cooling season. Clean using mild detergent or commercial coil cleaner. Flush coil and condensate drain with water taking care not to get insulation, filters and return air ducts wet.

### D - Condenser Coil

Clean condenser coil annually with water and inspect monthly during the cooling season.

### E - Compressor

## ⚠ IMPORTANT

Some scroll compressors have an internal vacuum protector that will unload scrolls when suction pressure goes below 20 psig. A hissing sound will be heard when the compressor is running unloaded. Protector will reset when low pressure in system rises above 40 psig. **DO NOT REPLACE COMPRESSOR.**

### F - Supply Air Blower Wheel

Annually inspect supply air blower wheel for accumulated dirt or dust. Turn off power before attempting to remove blower access panel or to clean blower wheel.



**DIAGNOSTIC CODES FOR DEFROST CONTROL LEADS**

(See instructions or markings on System Diagnostic Module for codes of System Diagnostic Module)

Description	DS1 (GREEN)	DS2 (RED)
No Power to Control	OFF	OFF
Normal Operation / Power to Control	Simultaneous Slow Flash	
Anti-Short Cycle Lockout	Alternate Slow Flash	
Low Pressure Switch Fault	OFF	Slow Flash
Low Pressure Switch Lockout	OFF	ON
High Pressure Switch Fault	Slow Flash	OFF
High Pressure Switch Lockout	ON	OFF

Note: Because the Pressure Switches are monitored only when "Y1" (input) is active, the code for pressure switch open will not be seen when "Y1" is off. Instead, the "Normal Operation" or "Anti Short Cycle" code will be seen.

Also, when a pressure switch opens and caused a short cycle lockout, the pressure switch-open code will be seen until it closes, then the short cycle lockout code will flash unless it has already expired.

J1: PLUG THROUGH CONTROL PANEL (12 PIN)  
 J2: PLUG FOR ACCESSORY HEAT (6 PIN)

**CONNECTION DIAGRAM, HEAT PUMP  
 CONSTANT TORQUE BLOWER, 3 PHASE - 230V**

NOTE: TAP1 FOR FAN ONLY  
 TAP2 FOR COOLING  
 TAP3 FOR HIGH STATIC COOLING  
 TAP4 AND TAP5 FOR ELECTRIC HEAT- REFER TO HEATING LABEL

**INDOOR BLOWER MOTOR**

W1 & W2 CAN BE USED TO STAGE  
 ELECTRIC HEAT ACCESSORY ON  
 10, 15, 20, & 23 KW MODELS  
 5 KW HEATER ACCESSORIES  
 FUNCTION OFF W1 ONLY.

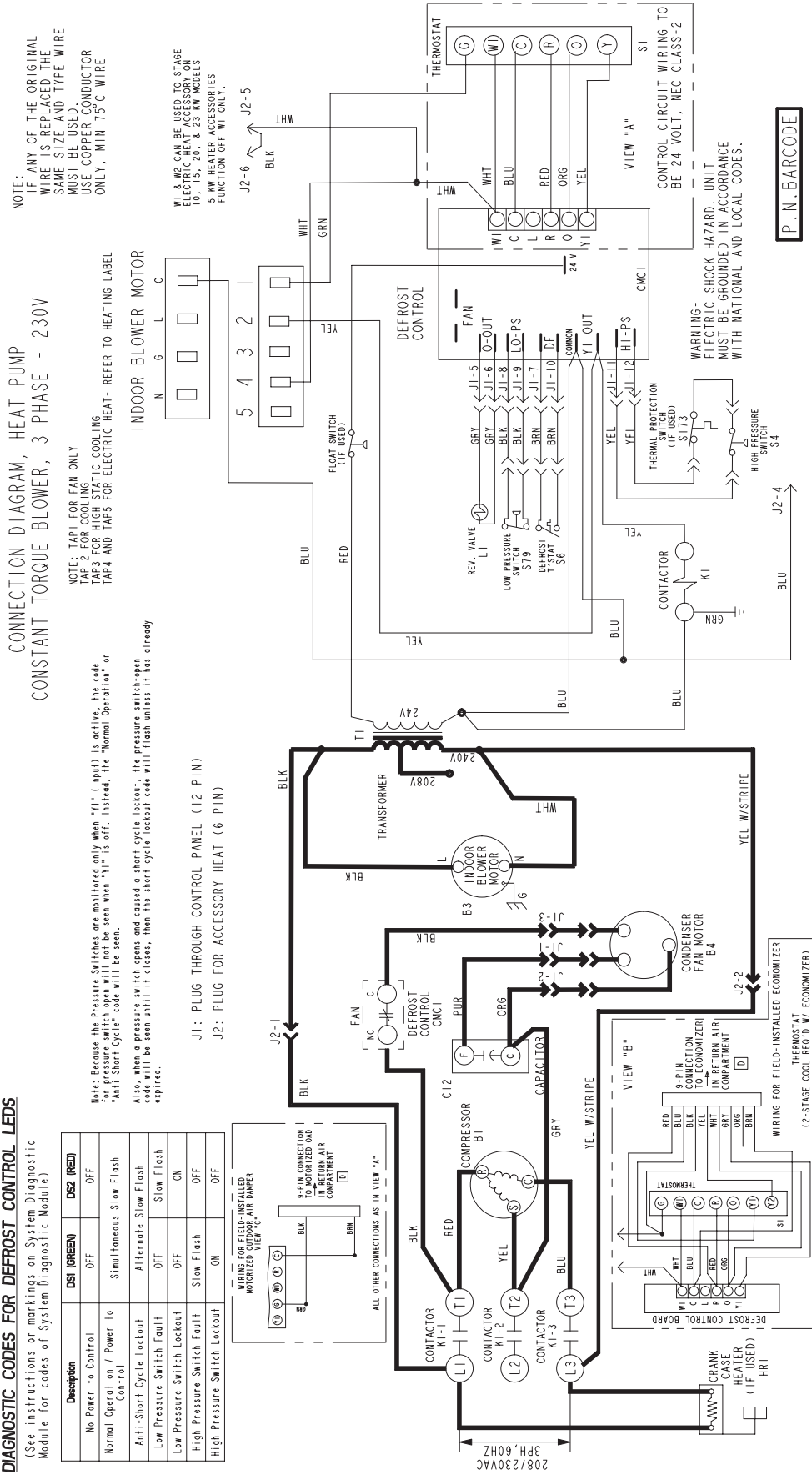

P. N. BARCODE

538133-01

LINE VOLTAGE FIELD INSTALLED

**FIGURE 10**

**DIAGNOSTIC CODES FOR DEFROST CONTROL LEDS**

(See instructions or markings on System Diagnostic Module for codes of System Diagnostic Module)

Description	DS1 (GREEN)	DS2 (RED)
No Power to Control	OFF	OFF
Normal Operation / Power to Control	Simultaneous Slow Flash	
Anti-Short Cycle Lockout	Alternate Slow Flash	
Low Pressure Switch Fault	OFF	Slow Flash
Low Pressure Switch Lockout	OFF	ON
High Pressure Switch Fault	Slow Flash	OFF
High Pressure Switch Lockout	ON	OFF

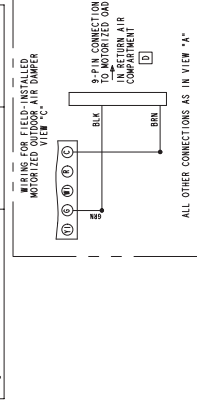

**CONNECTION DIAGRAM, HEAT PUMP CONSTANT TORQUE BLOWER, 3 PHASE - 460V**

NOTE: TAP1 FOR FAN ONLY  
TAP2 FOR COOLING  
TAP3 FOR HIGH STATIC COOLING  
TAP4 AND TAP5 FOR ELECTRIC HEAT- REFER TO HEATING LABEL

**INDOOR BLOWER MOTOR**



NOTE: IF ANY OF THE ORIGINAL WIRE IS REPLACED THE SAME SIZE AND TYPE WIRE MUST BE USED. USE COPPER CONDUCTOR ONLY, MIN 75°C WIRE

WI & W2 CAN BE USED TO STAGE ELECTRIC HEAT ACCESSORY ON 10, 15, 20, & 23 KW MODELS 5 KW HEATER ACCESSORIES FUNCTION OFF W/ ONLY.

Note: Because the Pressure Switches are monitored only when "Y1" (input) is active, the code for pressure switch open will not be seen when "Y1" is off. Instead, the "Normal Operation" or "Anti Short Cycle" code will be seen.

Also, when a pressure switch opens and caused a short cycle lockout, the pressure switch-open code will be seen until it closes, then the short cycle lockout code will flash unless it has already expired.

J1: PLUG THROUGH CONTROL PANEL (12 PIN)  
J2: PLUG FOR ACCESSORY HEAT (6 PIN)

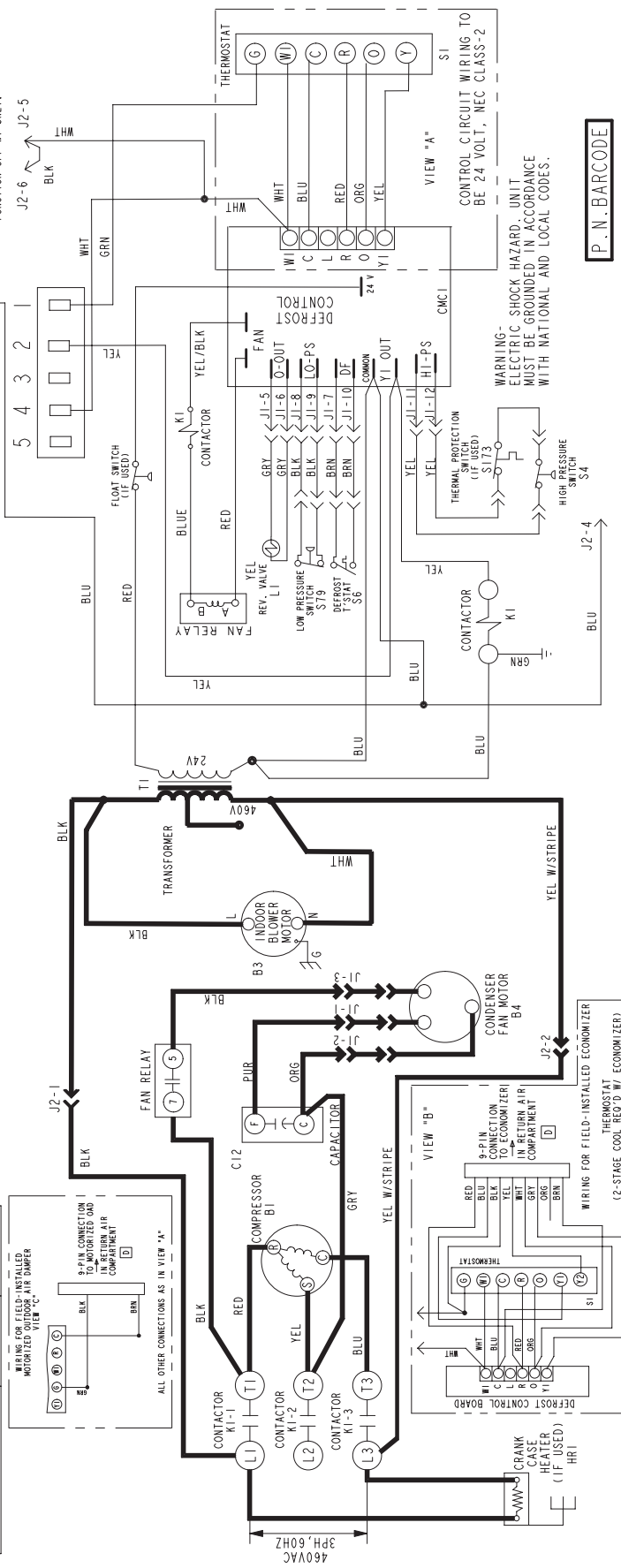

P. N. BARCODE

538163-01

LINE VOLTAGE FIELD INSTALLED

FIGURE 11



Job Name: \_\_\_\_\_  
 Store No. \_\_\_\_\_ Start-Up Date: \_\_\_\_\_  
 Address: \_\_\_\_\_  
 City: \_\_\_\_\_ State: \_\_\_\_\_  
 Start-Up Contractor: \_\_\_\_\_  
 Technician: \_\_\_\_\_  
 Model No. \_\_\_\_\_  
 Serial No. \_\_\_\_\_  
 RTU No. \_\_\_\_\_ Catalog No. \_\_\_\_\_

Inspection and Checks			
Damage?	Yes <input type="checkbox"/>	No <input type="checkbox"/>	R22 <input type="checkbox"/> R-410A <input type="checkbox"/>
If yes, reported to: _____			
Verify factory and field-installed accessories.			
Check electrical connections. Tighten if necessary.			
Supply voltage: L1-L2 _____ L1-L3 _____ L2-L3 _____			
If unit contains a 208-230/240 volt transformer:			
Check primary transformer tap <input type="checkbox"/>			
Transformer secondary voltage: _____			

Cooling Checks												
Compressor Rotation <input type="checkbox"/> Ambient Temp. _____ Return Air Temp. _____ Supply Air Temp. _____												
	Compressor Amps			Compressor Volts			Pressures		Condenser Fan Amps			CC Heater Amps
	L1	L2	L3	L1-L2	L1-L3	L2-L3	Disch.	Suct.	L1	L2	L3	L1
1												
2												
3												
4												

Blower Checks		
Pulley/Belt Alignment <input type="checkbox"/>	Blower Rotation <input type="checkbox"/>	
Set Screws Tight <input type="checkbox"/>	Belt Tension <input type="checkbox"/>	
Nameplate Amps: _____ Volts: _____		
Motor	Amps	Volts
_____	L1 _____	L1-L2 _____
_____	L1 _____	L1-L2 _____
_____	L1 _____	L1-L2 _____

Control Type

Accessory Checks	
Economizer Operation	
Min. Pos. <input type="checkbox"/>	Motor Travel full open/close <input type="checkbox"/>

Heating Checks - Electric							
Return Air Temp. _____ Supply Air Temp. _____							
Limits Operate: <input type="checkbox"/>							
	Amps						
	L1	L2	L3		L1	L2	L3
1				10			
2				11			
3				12			
4				13			
5				14			
6				15			
7				16			
8				17			
9				18			