

UNIT INFORMATION

LHX SERIES
15 to 25 ton

Service Literature

100139
Revised 01/2026

LHX180, 240 and 300 with R454B

The LHX180, 240, and 300 are configured to order units (CTO) with a wide selection of factory installed options.

Optional electric heat is field-installed. Electric heat operates in single or multiple stages depending on the kW input size. 15 kW to 60 kW heat sections are available for the LHX180 unit and 15 kW to 90 kW heat sections are available for LHX240 and LHX300.

Cooling capacities include 15, 20, and 25 tons. The LHX180, 240 utilize two compressors and four condenser fans. LHX300 utilizes two compressors and six condenser fans.

Multi-Stage Air Volume MSAV® blower option is available. The VFD-driven blower will operate at lower speeds when demand is low and increase to higher speeds when demand is high.

All LHX units are designed to accept any of several different energy management thermostat control systems with minimum field wiring. Factory- or field-provided control options connect to the unit through Smartwire connectors. When “plugged in” the controls become an integral part of the unit wiring.

The CORE Lite Control System is designed to accelerate equipment install and service. Standard with all Xion rooftop units, control system integrates key technologies that lower installation costs, drive system efficiency, and protect your investments.

The CORE Lite Unit Controller is a microprocessor-based controller that provides flexible control of all unit functions. Information contained in this manual is intended for use by qualified service technicians only. All specifications are subject to change. Procedures outlined in this manual are presented as a recommendation only and do not supersede or replace local or state codes.

If the unit must be lifted for service, rig unit by attaching four cables to the holes located in the unit base rail (two holes at each corner). Refer to the installation instructions for the proper rigging technique.

False ceilings or drop ceiling may be used as a return air plenum only if the unit being installed has a Refrigerant Detection System installed.

All maintenance staff and others working in the local area shall be instructed on the nature of work being carried out with work in confined spaces being avoided.

Ensure that the area is in the open or that it is adequately ventilated before breaking into the system or conducting any hot work. A degree of ventilation shall continue during the period that the work is carried out. The ventilation should safely disperse any released refrigerant and preferably expel it externally into the atmosphere.

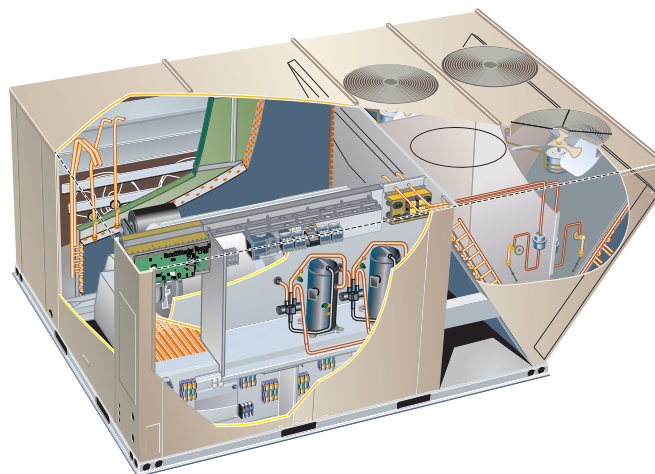

Table of Contents

Options / Accessories	Page 4
Specifications	Page 8
Blower Data	Page 9
Electrical / Electric Heat Data	Page 12
Unit Parts Arrangement	Page 18
I Unit Components	Page 21
II Placement and Installation	Page 37
III Charging	Page 37
IV Start-Up Operation	Page 40
V System Service Checks	Page 40
VI Maintenance	Page 40
VII Optional Accessories	Page 44
VIII Multi-Stage Blower	Page 48
IX Decommissioning	Page 50
X Wiring Diagrams and Sequence of Operation	Page 51

CAUTION

As with any mechanical equipment, contact with sharp sheet metal edges can result in personal injury. Take care while handling this equipment and wear gloves and protective clothing.

WARNING

Only manufacturer approved auxiliary devices are permitted to be installed in this unit.

CAUTION

The appliance is not to be used by persons (including children) with reduced physical, sensory or mental capabilities, or lack of experience and knowledge, unless they have been given supervision or instruction.

CAUTION

Children should be supervised not to play with the appliance.

CAUTION

Any personnel installing, decommissioning, or performing maintenance on the unit must be properly trained with A2L refrigerants.

CAUTION

Servicing shall be performed only as recommended by the manufacturer.

WARNING

- This appliance must be installed in accordance with local and national wiring regulations.
- If the appliance is not fitted with an option for full disconnection from power, a means of disconnection must be incorporated in the fixed wiring in accordance with national and local wiring regulations.

CAUTION

Leak Detection System installed. Unit must be powered except for service.

WARNING

Ducts connected to an appliance shall not contain a potential ignition source.

IMPORTANT

Pipe work, including piping material, pipe routing, and installation shall include protection from physical damage in operation and service, and be in compliance with national and local codes and standards, such as ASHRAE 15, ASHRAE 15.2, IAPMO Uniform Mechanical Code, ICC International Mechanical Code, or CSA B52. All field joints shall be accessible for inspection prior to being covered or enclosed.

IMPORTANT

Refrigerant sensors for refrigerant detection systems shall only be replaced with sensors specified by the appliance manufacturer.

CAUTION

This unit is equipped with electrically powered safety measures. To be effective, the unit must be electrically powered at all times after installation, other than when servicing.

WARNING

Improper installation, adjustment, alteration, service or maintenance can cause property damage, personal injury or loss of life. Installation and service must be performed by a licensed professional HVAC installer or equivalent, service agency, or the gas supplier.

WARNING

- To prevent serious injury or death:
- 1- Lock-out/tag-out before performing maintenance.
 - 2- If system power is required (e.g., smoke detector maintenance), disable power to blower, remove fan belt where applicable, and ensure all controllers and thermostats are set to the "OFF" position before performing maintenance.
 - 3- Always keep hands, hair, clothing, jewelry, tools, etc., away from moving parts.

A2L Refrigerant Considerations

Ensure that the work area is adequately ventilated before breaking into the system or conducting any hot work. A degree of ventilation shall continue during the period that the work is carried out. The ventilation should safely disperse any released refrigerant and preferably expel it externally into the atmosphere.

Check that cabling will not be subject to wear, corrosion, excessive pressure, vibration, sharp edges or any other adverse environmental effects, taking into account the effects of aging or continual vibration from sources such as compressors or fans.

Under no circumstances shall potential sources of ignition be used when searching for or detection of refrigerant leaks. A halide torch (or any other detector using a naked flame) shall not be used. Electronic leak detectors may be used to detect refrigerant leaks but, in the case of flammable refrigerants, the sensitivity may not be adequate, or may need re-calibration. (Detection equipment shall be calibrated in a refrigerant-free area.) Ensure that the detector is not a potential source of ignition and is suitable for the refrigerant used. Leak detection equipment shall be set at a percentage of the LFL of the refrigerant and shall be calibrated to the refrigerant employed, and the appropriate percentage of gas (25 % maximum) is confirmed. Leak detection fluids are also suitable for use with most refrigerants but the use of detergents containing chlorine shall be avoided as the chlorine may react with the refrigerant and corrode the copper pipe-work. If a leak is suspected, all naked flames shall be removed/extinguished. If a leakage of refrigerant is found which requires brazing, all of the refrigerant shall be recovered from the system, or isolated (by means of shut off valves) in a part of the system remote from the leak.

When breaking into the refrigerant circuit to make repairs – or for any other purpose – conventional procedures shall be used. However, for flammable refrigerants it is important that best practices be followed since flammability is a consideration. The following procedure shall be adhered to:

- Safely remove refrigerant following local and national regulations.

- Evacuate the circuit.

- Purge the circuit with inert gas.

- Evacuate.

- Purge the circuit with inert gas.

- Open the circuit

The refrigerant charge shall be recovered into the correct recovery cylinders if venting is not allowed by local and national codes. For appliances containing flammable refrigerants, the system shall be purged with oxygen-free nitrogen to render the appliance safe for flammable refrigerants. This process might need to be repeated several times. Compressed air or oxygen shall not be used for purging refrigerant systems. Refrigerants purging shall be achieved by breaking the vacuum in the system with oxygen-free nitrogen and continuing to fill until the working pressure is achieved, then venting to atmosphere, and finally pulling down to a vacuum. This process shall be vented down to atmospheric pressure to enable work to take place. Ensure that the outlet for the vacuum pump is not close to any potential ignition sources and that ventilation is available.

OPTIONS / ACCESSORIES

Item Description	Order Number	Size			
		180	240	300	
COOLING SYSTEM					
Condensate Drain Trap	PVC	22H54	X	X	X
	Copper	76W27	X	X	X
Drain Pan Overflow Switch		21Z07	X	X	X
BLOWER - SUPPLY AIR					
Blower Options	MSAV Multi-Stage Air Volume	Factory	O	O	O
Motors - MSAV® Multi-Stage Air Volume	Belt Drive - 3 HP	Factory	O		
	Belt Drive - 5 HP	Factory	O	O	O
	Belt Drive - 7.5 HP	Factory	O	O	O
	Belt Drive - 10 HP	Factory		O	O
VFD Bypass Kit (for MSAV® equipped units)	3, 5, 7.5 HP - No Overload	37G64	X		
	10 HP - With Overload	37G65	X		
Drive Kits See Blower Data Tables for usage and selection	Kit #1 535-725 rpm	Factory	O		
	Kit #2 710-965 rpm	Factory	O		
	Kit #3 685-856 rpm	Factory	O	O	O
	Kit #4 850-1045 rpm	Factory	O	O	O
	Kit #5 945-1185 rpm	Factory	O	O	O
	Kit #6 850-1045 rpm	Factory	O	O	O
	Kit #7 945-1185 rpm	Factory	O	O	O
	Kit #8 1045-1285 rpm	Factory	O	O	O
	Kit #10 1045-1285 rpm	Factory		O	O
	Kit #11 1135-1330 rpm	Factory		O	O
	CABINET				
Burglar Bars	(US)	44N20	X	X	X
	(CA)	X2889	X	X	X
Combination Coil/Hail Guards		23U71	OX	OX	OX
Hinged Access Panels		Factory	O	O	O
CONTROLS					
NOTE - Also see Conventional Thermostat Control Systems on pagepage 11 for Additional Options.					
BACnet® MS/TP Module		38B35	X	X	X
Dirty Filter Switch		53W68	X	X	X
Smoke Detector - Supply or Return (Power board and one sensor)		37G73	X	X	X
Smoke Detector - Supply and Return (Power board and two sensors)		37G74	X	X	X

NOTE - Order numbers shown are for ordering field installed accessories.

OX - Configure To Order (Factory Installed) or Field Installed

O = Configure To Order (Factory Installed)

X = Field Installed

OPTIONS / ACCESSORIES

Item Description	Order Number	Size			
		180	240	300	
INDOOR AIR QUALITY					
Air Filters					
Healthy Climate® High Efficiency Air Filters 24 x 24 x 2 (Order 6 per unit)	MERV 8	54W67	X	X	X
	MERV 13	52W40	X	X	X
	MERV 16	21U42	X	X	X
Replacement Media Filter With Metal Mesh Frame (includes non-pleated filter media)		44N61	X	X	X
Indoor Air Quality (CO₂) Sensors					
Sensor - Wall-mount, off-white plastic cover with LCD display		77N39	X	X	X
Sensor - Wall-mount, off-white plastic cover, no display		23V86	X	X	X
Sensor - Black plastic case, LCD display, rated for plenum mounting		87N52	X	X	X
Sensor - Black plastic case, no display, rated for plenum mounting		23V87	X	X	X
CO ₂ Sensor Duct Mounting Kit - for downflow applications		23Y47	X	X	X
Aspiration Box - for duct mounting non-plenum rated CO ₂ sensors (77N39)		90N43	X	X	X
Needlepoint Bipolar Ionization (NPBI)					
Needlepoint Bipolar Ionization Kits		21U37	X		
		21U38		X	
		21U39			X
UVC Germicidal Light Kit					
¹ Healthy Climate® UVC Light Kit (110/230v-1ph)		21A94	X	X	X
Step-Down Transformers	460V primary, 230V secondary	10H20	X	X	X
	575V primary, 230V secondary	10H21	X	X	X
ELECTRICAL					
Voltage 60 Hz	208/230V - 3 phase	Factory	O	O	O
	460V - 3 phase	Factory	O	O	O
	575V - 3 phase	Factory	O	O	O
Disconnect Switch (see Electric Heat Tables for usage)	80 amp	54W85	OX	OX	OX
	150 amp	54W86	OX	OX	OX
	250 amp	54W87	OX	OX	OX
GFI Service Outlets	15 amp non-powered, field-wired (208/230V, 460V only)	74M70	OX	OX	OX
	² 20 amp non-powered, field-wired (208/230V, 460V, 575V)	67E01	X	X	X
	² 20 amp non-powered, field-wired (575V)	Factory	O	O	O
Weatherproof Cover for GFI		10C89	X	X	X
ELECTRIC HEAT					
15 kW	208/230V-3ph	30U62	X	X	X
	460V-3ph	30U63	X	X	X
	575V-3ph	30U64	X	X	X
30 kW	208/230V-3ph	30U68	X	X	X
	460V-3ph	30U69	X	X	X
	575V-3ph	30U70	X	X	X
45 kW	208/230V-3ph	30U74	X	X	X
	460V-3ph	30U75	X	X	X
	575V-3ph	30U76	X	X	X
60 kW	208/230V-3ph	30U80	X	X	X
	460V-3ph	30U81	X	X	X
	575V-3ph	30U82	X	X	X
90 kW	208/230V-3ph	30U83		X	
	460V-3ph	30U84		X	X
	575V-3ph	30U85		X	X

¹ Lamps operate on 110-230V single-phase power supply. Step-down transformer may be ordered separately for 460V and 575V units. Alternately, 110V power supply may be used to directly power the UVC ballast(s).

² Canada requires a minimum 20 amp circuit. Select 20 amp, non-powered, field wired GFI.

NOTE - Order numbers shown are for ordering field installed accessories.

OX - Configure To Order (Factory Installed) or Field Installed

O = Configure To Order (Factory Installed)

X = Field Installed

OPTIONS / ACCESSORIES

Item Description	Order Number	Size		
		180	240	300
ECONOMIZER				
High Performance Economizer (Approved for California Title 24 Building Standards AMCA Class 1A Certified)				
High Performance Economizer (Downflow or Horizontal) Includes Economizer Dampers with Outdoor Air Hood Downflow Applications - Use furnished Outdoor Air Hood - Order Downflow Barometric Relief Dampers with Exhaust Hood separately Horizontal Applications - Use furnished Outdoor Air Hood - Order Horizontal Barometric Relief Dampers with Exhaust Hood separately	22J18	OX	OX	OX
Economizer Controls				
Differential Enthalpy (Not for Title 24)	Order 2 21Z09	X	X	X
Sensible Control	Sensor is Furnished Factory	O	O	O
Single Enthalpy (Not for Title 24)	21Z09	O	O	O
Barometric Relief Dampers With Exhaust Hood				
Downflow Barometric Relief Dampers	54W78	OX	OX	OX
Horizontal Barometric Relief Dampers	16K99	X	X	X
OUTDOOR AIR				
Outdoor Air Dampers With Outdoor Air Hood				
Motorized	22J27	X	X	X
Manual	13U05	X	X	X
³ POWER EXHAUST (DOWNFLOW APPLICATIONS ONLY)				
Standard Static, SCCR Rated	208/230V 22H90	X	X	X
	460V 22H91	X	X	X
	575V 22V34	X	X	X

³ Field installed Power Exhaust requires Economizer with Outdoor Air Hood and Downflow Barometric Relief Dampers with Exhaust Hood. Must be ordered separately.

NOTE - Order numbers shown are for ordering field installed accessories.

OX - Configure To Order (Factory Installed) or Field Installed

O = Configure To Order (Factory Installed)

X = Field Installed

OPTIONS / ACCESSORIES

Item Description	Order Number	Size		
		180	240	300
ROOF CURBS				
Hybrid Roof Curbs, Downflow				
8 in. height	11F58	X	X	X
14 in. height	11F59	X	X	X
18 in. height	11F60	X	X	X
24 in. height	11F61	X	X	X
Adjustable Pitch Curb				
14 in. height	43W26	X	X	X
Standard Roof Curbs, Horizontal - Requires Horizontal Return Air Panel Kit				
26 in. height - slab applications	11T89	X	X	
30 in. height - slab applications	11T90			X
37 in. height - rooftop applications	11T96	X	X	
41 in. height - rooftop applications	11T97			X
Insulation Kit For Standard Horizontal Curbs				
For 26 in. Curb	73K32	X	X	
For 30 in. Curb	73K33			X
For 37 in. Curb	73K34	X	X	
For 41 in. Curb	73K35			X
Horizontal Return Air Panel Kit				
Required for Horizontal Applications with Roof Curb	87M00	X	X	X
CEILING DIFFUSERS				
Step-Down - Order one	RTD11-185S	13K63	X	
	RTD11-275S	13K64		X
Flush - Order one	FD11-185S	13K58	X	
	FD11-275S	13K59		X
Transitions (Supply and Return) - Order one	C1DIFF33C-1	12X68	X	
	C1DIFF34C-1	12X70		X

NOTE - Order numbers shown are for ordering field installed accessories.

OX - Configure To Order (Factory Installed) or Field Installed

O = Configure To Order (Factory Installed)

X = Field Installed

SPECIFICATIONS

Model		LHX180S5M	LHX240S5M	LHX300S5M	
Nominal Tonnage		15 Ton	20 Ton	25 Ton	
Efficiency Type		Standard	Standard	Standard	
Blower Type		MSAV® Multi-Stage Air Volume	MSAV® Multi-Stage Air Volume	MSAV® Multi-Stage Air Volume	
Cooling Performance	Gross Cooling Capacity (Btuh)	181,000	232,000	275,000	
	¹ Net Cooling Capacity (Btuh)	176,000	224,000	262,000	
	¹ AHRI Rated Air Flow (cfm)	5500	7000	9000	
	¹ IEER (Btuh/Watt)	13.5	13.5	13.0	
	¹ EER (Btuh/Watt)	10.6	10.6	10.0	
	Total Unit Power (kW)	16.6	21.1	26.2	
Heating Performance	¹ Total High Heating Capacity (Btuh)	172,000	224,000	270,000	
	¹ COP	3.30	3.30	3.3	
	Total Unit Power (kW)	15.3	19.9	23.9	
	¹ Total Low Heating Capacity (Btuh)	98,000	124,000	160,000	
	¹ COP	2.1	2.1	2.2	
	Total Unit Power (kW)	13.7	17.3	21.3	
Sound Rating Number		dBA	93	93	94
Refrigerant Charge	Refrigerant Type		R-454B	R-454B	R-454B
	Circuit 1		22 lbs. 8 oz.	22 lbs. 0 oz.	22 lbs. 3 oz.
	Circuit 2		20 lbs. 3 oz.	21 lbs. 8 oz.	21 lbs. 0 oz.
Electric Heat Available		See page 5			
Compressor Type (number)		Scroll (2)	Scroll (2)	Scroll (2)	
Outdoor Coils	Net face area - ft.² (total)		55.1	55.1	46
	Rows		2	2	3
	Fins - in.		20	20	14
Outdoor Coil Fans	Motor HP (number and type)		1/3 (4 PSC)	1/3 (4 PSC)	1/2 (6 PSC)
	Rpm		1075	1075	1075
	Watts		1750	1750	3000
	Diameter - (No.) in.		(4) 24	(4) 24	(6) 24
	Blades		3	3	3
	Total Air volume - cfm		16,000	16,000	21,500
	Indoor Coils	Net face area - ft.² (total)		21.4	21.4
Tube diameter - in.		3/8	3/8	3/8	
Rows		3	4	4	
Fins - in.		14	14	14	
Condensate drain size (NPT) - in.		(1) 1 in.	(1) 1 in.	(1) 1 in.	
² Indoor Blower and Drive Selection	Expansion device type		Balanced Port Thermostatic Expansion Valve		
	Nominal motor HP		3, 5, 7.5	5, 7.5, 10	5, 7.5, 10
	Maximum usable motor HP (US)		3.45, 5.75, 8.62	5.75, 8.63, 11.5	5.75, 8.63, 11.5
	Motor - Drive kit number		3 HP Kit 1 535-725 rpm Kit 2 710-965 rpm	5 HP Kit 3 685-856 rpm Kit 4 850-1045 rpm Kit 5 945-1185 rpm	5 HP Kit 3 685-856 rpm Kit 4 850-1045 rpm Kit 5 945-1185 rpm
			5 HP Kit 3 685-856 rpm Kit 4 850-1045 rpm Kit 5 945-1185 rpm	7.5 HP Kit 6 850-1045 rpm Kit 7 945-1185 rpm Kit 8 1045-1285 rpm	7.5 HP Kit 6 850-1045 rpm Kit 7 945-1185 rpm Kit 8 1045-1285 rpm
			7.5 HP Kit 6 850-1045 rpm Kit 7 945-1185 rpm Kit 8 1045-1285 rpm	10 HP Kit 7 945-1185 rpm Kit 10 1045-1285 rpm Kit 11 1135-1330 rpm	10 HP Kit 7 945-1185 rpm Kit 10 1045-1285 rpm Kit 11 1135-1330 rpm
				(2) 15 x 15	
				MERV 4, Disposable	
				(6) 24 x 24 x 2	
				208/230-3-60	
			460-3-60		
			575-3-60		
Filters		Type of filter			
		MERV 4, Disposable			
		(6) 24 x 24 x 2			
Line voltage data (Volts-Phase-Hz)		208/230-3-60			
		460-3-60			
		575-3-60			

NOTE - Gross cooling capacity includes evaporator blower motor heat deduction. Net cooling capacity does not include evaporator blower motor heat deduction.

¹ AHRI Certified to AHRI Standard 340/360:

Cooling Ratings - 95°F outdoor air temperature and 80°F db/67°F wb entering indoor coil air.

High Temperature Heating Ratings - 47°F db/43°F wb outdoor air temperature and 70°F entering indoor coil air.

Low Temperature Heating Ratings - 17°F db/15°F wb outdoor air temperature and 70°F entering indoor coil air.

² Using total air volume and system static pressure requirements determine from blower performance tables rpm and motor output required. Maximum usable output of motors furnished are shown. In Canada, nominal motor output is also maximum usable motor output. If motors of comparable output are used, be sure to keep within the service factor limitations outlined on the motor nameplate.

NOTE - Motor service factor limit - 1.0.

BLOWER DATA

BLOWER TABLE INCLUDES RESISTANCE FOR BASE UNIT ONLY WITH DRY INDOOR COIL & AIR FILTERS IN PLACE

FOR ALL UNITS ADD:

- 1 - Wet indoor coil air resistance of selected unit.
- 2 - Any factory installed options air resistance (electric heat, economizer, etc.)
- 3 - Any field installed accessories air resistance (electric heat, duct resistance, diffuser, etc.)

Then determine from blower table blower motor output and drive required.

See page 10 for wet coil and option/accessory air resistance data.

See page 11 for factory installed drive kit specifications.

See page 11 for minimum air volume required for use with optional electric heat.

Air Volume cfm	TOTAL STATIC PRESSURE - Inches Water Gauge (Pa)																											
	0.20		0.40		0.60		0.80		1.00		1.20		1.40		1.60		1.80		2.00		2.20		2.40		2.60			
	RPM	BHP	RPM	BHP	RPM	BHP	RPM	BHP	RPM	BHP	RPM	BHP	RPM	BHP	RPM	BHP	RPM	BHP	RPM	BHP	RPM	BHP	RPM	BHP	RPM	BHP		
3250	405	0.40	520	0.60	615	0.85	695	1.10	765	1.30	830	1.60	890	1.85	950	2.10	1005	2.25	1060	2.55	1110	3.00	1160	3.30	1210	3.30	1260	3.30
3500	415	0.45	530	0.70	620	0.95	700	1.20	775	1.45	840	1.70	900	2.00	955	2.25	1010	2.45	1065	2.70	1120	3.00	1170	3.30	1220	3.30	1270	3.30
3750	425	0.50	540	0.75	630	1.05	710	1.30	780	1.60	845	1.85	905	2.15	960	2.45	1015	2.70	1070	2.90	1125	3.00	1175	3.30	1225	3.30	1275	3.30
4000	435	0.55	545	0.85	635	1.10	715	1.40	785	1.70	850	2.00	910	2.30	965	2.60	1020	2.90	1075	3.00	1130	3.25	1180	3.55	1230	3.55	1280	3.55
4250	445	0.60	555	0.90	645	1.25	725	1.55	795	1.85	855	2.15	915	2.45	970	2.80	1025	3.10	1080	3.25	1135	3.45	1185	3.75	1235	3.75	1285	3.75
4500	455	0.70	565	1.00	655	1.35	730	1.65	800	2.00	865	2.35	925	2.65	980	3.00	1030	3.30	1085	3.30	1140	3.65	1190	4.05	1240	4.05	1290	4.05
4750	470	0.75	575	1.10	660	1.45	740	1.80	810	2.15	870	2.50	930	2.85	985	3.20	1040	3.55	1095	3.50	1150	3.90	1200	4.25	1250	4.25	1300	4.25
5000	480	0.85	585	1.25	670	1.60	750	1.95	815	2.30	880	2.70	940	3.05	995	3.40	1045	3.80	1095	4.15	1145	4.50	1195	4.80	1245	4.80	1295	4.80
5250	495	0.95	595	1.35	680	1.70	755	2.10	825	2.50	890	2.90	945	3.25	1000	3.65	1050	4.00	1100	4.40	1150	4.70	1200	5.10	1250	5.10	1300	5.10
5500	505	1.05	605	1.45	690	1.85	765	2.25	835	2.65	895	3.05	955	3.45	1010	3.85	1060	4.25	1110	4.70	1160	5.05	1210	5.35	1260	5.35	1310	5.35
5750	520	1.15	615	1.60	700	2.00	775	2.45	840	2.85	905	3.25	960	3.65	1015	4.10	1065	4.50	1115	4.95	1165	5.35	1215	5.65	1265	5.65	1315	5.65
6000	530	1.30	630	1.75	710	2.15	785	2.60	850	3.05	910	3.45	970	3.90	1025	4.35	1075	4.80	1120	5.20	1170	5.65	1220	5.95	1270	5.95	1320	5.95
6250	545	1.40	640	1.90	720	2.35	795	2.80	860	3.25	920	3.70	975	4.15	1030	4.60	1080	5.05	1130	5.50	1175	5.95	1225	6.25	1275	6.25	1325	6.25
6500	560	1.55	650	2.05	730	2.50	805	3.00	870	3.45	930	3.95	985	4.40	1040	4.85	1090	5.35	1140	5.85	1185	6.30	1235	6.60	1285	6.60	1335	6.60
6750	570	1.70	665	2.20	745	2.70	815	3.20	880	3.70	940	4.20	995	4.65	1045	5.10	1095	5.60	1145	6.10	1190	6.60	1240	6.90	1290	6.90	1340	6.90
7000	585	1.85	675	2.35	755	2.90	825	3.40	890	3.95	950	4.45	1005	4.95	1055	5.40	1105	5.95	1155	6.45	1200	6.95	1250	7.25	1300	7.25	1350	7.25
7250	600	2.00	690	2.60	765	3.10	835	3.65	900	4.15	955	4.65	1010	5.25	1065	5.75	1115	6.25	1160	6.75	1210	7.10	1260	7.40	1310	7.40	1360	7.40
7500	615	2.20	700	2.75	775	3.30	845	3.85	910	4.45	965	4.95	1020	5.50	1075	6.05	1125	6.60	1170	7.15	1215	7.65	1265	7.95	1315	7.95	1365	7.95
7750	630	2.40	715	3.00	790	3.55	855	4.10	920	4.70	975	5.25	1030	5.80	1080	6.35	1130	6.90	1180	7.50	1225	8.05	1275	8.35	1325	8.35	1375	8.35
8000	640	2.55	725	3.20	800	3.80	865	4.35	930	4.95	985	5.50	1040	6.10	1090	6.70	1140	7.25	1190	7.85	1235	8.40	1285	8.70	1335	8.70	1385	8.70
8250	655	2.80	740	3.40	810	4.00	880	4.65	940	5.25	995	5.85	1050	6.45	1100	7.05	1150	7.65	1200	8.25	1245	8.85	1295	9.15	1345	9.15	1395	9.15
8500	670	3.00	750	3.65	825	4.30	890	4.90	950	5.55	1005	6.15	1060	6.80	1110	7.40	1160	8.05	1210	8.65	1255	9.25	1305	9.55	1355	9.55	1405	9.55
8750	685	3.25	765	3.90	835	4.55	900	5.20	960	5.85	1015	6.45	1070	7.15	1120	7.75	1165	8.35	1215	9.05	1255	9.65	1305	10.00	1355	10.00	1405	10.00
9000	700	3.50	780	4.20	850	4.85	910	5.50	970	6.15	1025	6.80	1080	7.50	1130	8.15	1175	8.75	1220	9.40	1265	10.10	1315	10.40	1365	10.40	1415	10.40
9250	715	3.75	790	4.45	860	5.15	925	5.85	985	6.55	1040	7.20	1090	7.85	1140	8.55	1185	9.20	1230	9.85	1275	10.55	1325	10.85	1375	10.85	1425	10.85
9500	730	4.00	805	4.75	875	5.45	935	6.15	995	6.90	1050	7.60	1100	8.25	1150	8.95	1195	9.60	1240	10.30	1285	11.05	1335	11.35	1385	11.35	1435	11.35
9750	745	4.30	820	5.05	885	5.75	950	6.55	1005	7.20	1060	7.95	1110	8.65	1160	9.40	1205	10.05	1250	10.80	1295	11.50	1345	11.80	1395	11.80	1445	11.80
10,000	760	4.60	835	5.40	900	6.15	960	6.85	1015	7.60	1070	8.35	1120	9.05	1170	9.80	1215	10.50	1260	11.25	1305	12.00	1355	12.30	1405	12.30	1455	12.30
10,250	775	4.90	845	5.65	910	6.45	970	7.20	1030	8.00	1080	8.75	1135	9.55	1180	10.25	1225	11.00	1270	11.90	1315	12.75	1365	13.05	1415	13.05	1465	13.05
10,500	790	5.20	860	6.00	925	6.85	985	7.65	1040	8.40	1095	9.20	1145	10.00	1190	10.70	1235	11.45	1280	12.40	1325	13.50	1375	13.85	1425	13.85	1475	13.85
10,750	805	5.55	875	6.40	940	7.25	1000	8.05	1055	8.85	1105	9.65	1155	10.45	1200	11.20	1245	12.15	1290	13.15	1335	14.25	1385	14.60	1435	14.60	1485	14.60
11,000	820	5.90	890	6.80	950	7.60	1010	8.45	1065	9.30	1115	10.05	1165	10.90	1210	11.90	1255	13.05	1300	14.10	1345	15.35	1395	15.70	1445	15.70	1495	15.70

BLOWER DATA

FACTORY INSTALLED BELT DRIVE KIT SPECIFICATIONS

Nominal HP	Maximum HP	Drive Kit Number	RPM Range
3	3.45	1	535 - 725
3	3.45	2	710 - 965
5	5.75	3	685 - 856
5	5.75	4	850 - 1045
5	5.75	5	945 - 1185
7.5	8.63	6	850 - 1045
7.5	8.63	7	945 - 1185
7.5	8.63	8	1045 - 1285
10	11.50	7	945 - 1185
10	11.50	10	1045 - 1285
10	11.50	11	1135 - 1330

NOTE - Using total air volume and system static pressure requirements determine from blower performance tables rpm and motor output required. Maximum usable output of motors furnished are shown. In Canada, nominal motor output is also maximum usable motor output. If motors of comparable output are used, be sure to keep within the service factor limitations outlined on the motor nameplate.

NOTE - Motor service factor limit - 1.0.

FACTORY INSTALLED OPTIONS/FIELD INSTALLED ACCESSORY AIR RESISTANCE - in. w.g.

Air Volume cfm	Wet Indoor Coil	Electric Heat	Economizer	Filters			Horizontal Roof Curb
				MERV 8	MERV 13	MERV 16	
3250	0.03	---	---	0.01	0.04	0.07	0.04
3500	0.03	---	---	0.01	0.04	0.08	0.05
3750	0.03	---	---	0.01	0.04	0.08	0.05
4000	0.04	---	---	0.01	0.04	0.09	0.06
4250	0.04	---	---	0.01	0.05	0.10	0.07
4500	0.05	---	---	0.01	0.05	0.10	0.07
4750	0.05	---	---	0.02	0.05	0.11	0.08
5000	0.05	---	---	0.02	0.06	0.12	0.08
5250	0.06	---	---	0.02	0.06	0.12	0.09
5500	0.07	---	---	0.02	0.06	0.13	0.10
5750	0.07	---	---	0.02	0.07	0.14	0.11
6000	0.08	0.01	---	0.03	0.07	0.14	0.11
6250	0.08	0.01	0.01	0.03	0.07	0.15	0.12
6500	0.09	0.01	0.02	0.03	0.08	0.16	0.13
6750	0.10	0.01	0.03	0.03	0.08	0.17	0.14
7000	0.10	0.01	0.04	0.04	0.08	0.17	0.15
7250	0.11	0.01	0.05	0.04	0.09	0.18	0.16
7500	0.12	0.01	0.06	0.04	0.09	0.19	0.17
8000	0.13	0.02	0.09	0.05	0.10	0.21	0.19
8500	0.15	0.02	0.11	0.05	0.10	0.22	0.21
9000	0.16	0.04	0.14	0.06	0.11	0.24	0.24
9500	0.18	0.05	0.16	0.07	0.12	0.25	0.26
10,000	0.20	0.06	0.19	0.07	0.12	0.27	0.29
10,500	0.22	0.09	0.22	0.08	0.13	0.29	0.31
11,000	0.24	0.11	0.25	0.09	0.14	0.30	0.34

BLOWER DATA

MINIMUM AIR VOLUME REQUIRED FOR USE WITH OPTIONAL ELECTRIC HEAT

Electric Heat kW	Minimum cfm
15	6000
30	6000
45	6000
60	6000
90	6000

POWER EXHAUST FAN PERFORMANCE

Return Air System Static Pressure in. w.g.	Air Volume Exhausted cfm
0.00	8630
0.05	8210
0.10	7725
0.15	7110
0.20	6470
0.25	5790
0.30	5060
0.35	4300
0.40	3510
0.45	2690
0.50	1840

CEILING DIFFUSER AIR RESISTANCE - in. w.g.

Air Volume cfm	Step-Down Diffuser						Flush Diffuser	
	RTD11-185S			RTD11-275			FD11-185S	FD11-275
	2 Ends Open	1 Side/2 Ends Open	All Ends & Sides Open	2 Ends Open	1 Side/2 Ends Open	All Ends & Sides Open		
5000	.51	.44	.39	---	---	---	.27	---
5200	.56	.48	.42	---	---	---	.30	---
5400	.61	.52	.45	---	---	---	.33	---
5600	.66	.56	.48	---	---	---	.36	---
5800	.71	.59	.51	---	---	---	.39	---
6000	.76	.63	.55	.36	.31	.27	.42	.29
6200	.80	.68	.59	---	---	---	.46	---
6400	.86	.72	.63	---	---	---	.50	---
6500	---	---	---	.42	.36	.31	---	.34
6600	.92	.77	.67	---	---	---	.54	---
6800	.99	.83	.72	---	---	---	.58	---
7000	1.03	.87	.76	.49	.41	.36	.62	.40
7200	1.09	.92	.80	---	---	---	.66	---
7400	1.15	.97	.84	---	---	---	.70	---
7500	---	---	---	.51	.46	.41	---	.45
7600	1.20	1.02	.88	---	---	---	.74	---
8000	---	---	---	.59	.49	.43	---	.50
8500	---	---	---	.69	.58	.50	---	.57
9000	---	---	---	.79	.67	.58	---	.66
9500	---	---	---	.89	.75	.65	---	.74
10,000	---	---	---	1.00	.84	.73	---	.81
10,500	---	---	---	1.10	.92	.80	---	.89
11,000	---	---	---	1.21	1.01	.88	---	.96

CEILING DIFFUSER AIR THROW DATA

Size	Air Volume cfm	¹ Effective Throw Range - ft.		Size	Air Volume cfm	¹ Effective Throw Range - ft.	
		RTD11-185S Step-Down	FD11-185S Flush			RTD11-275 Step-Down	FD11-275 Flush
180	5600	39 - 49	28 - 37	240, 300	7200	33 - 38	26 - 35
	5800	42 - 51	29 - 38		7400	35 - 40	28 - 37
	6000	44 - 54	40 - 50		7600	36 - 41	29 - 38
	6200	45 - 55	42 - 51		7800	38 - 43	40 - 50
	6400	46 - 55	43 - 52		8000	39 - 44	42 - 51
	6600	47 - 56	45 - 56		8200	41 - 46	43 - 52
					8400	43 - 49	44 - 54
					8600	44 - 50	46 - 57
					8800	47 - 55	48 - 59

¹ Throw is the horizontal or vertical distance an airstream travels on leaving the outlet or diffuser before the maximum velocity is reduced to 50 ft. per minute. Four sides open.

ELECTRICAL/ELECTRIC HEAT DATA

15 TON

Model		LHX180S5M								
¹ Voltage - 60Hz		208/230V - 3 Ph			460V - 3 Ph			575V - 3 Ph		
Compressor 1 (Non-Inverter)	Rated Load Amps	24.4			11.9			9.4		
	Locked Rotor Amps	210			103			78		
Compressor 2 (Non-Inverter)	Rated Load Amps	27.7			11.5			9		
	Locked Rotor Amps	178.5			103			78		
Outdoor Fan Motors (4)	Full Load Amps (4 Non-ECM)	2.4			1.3			1		
	Total	9.6			5.2			4		
Power Exhaust (2) 0.33 HP	Full Load Amps	2.4			1.3			1		
	Total	4.8			2.6			2		
Service Outlet 115V GFI (amps)		15			15			20		
Indoor Blower Motor	HP	3	5	7.5	3	5	7.5	3	5	7.5
	Full Load Amps	10.6	16.7	24.2	4.8	7.6	11	3.9	6.1	9
² Maximum Overcurrent Protection (MOCP)	Unit Only	100	110	110	45	50	50	35	40	40
	With (2) 0.33 HP Power Exhaust	110	110	125	50	50	50	40	40	45
³ Minimum Circuit Ampacity (MCA)	Unit Only	80	86	93	37	40	43	29	31	34
	With (2) 0.33 HP Power Exhaust	85	91	98	39	42	46	31	33	36

ELECTRIC HEAT DATA

Electric Heat Voltage			208V	240V	208V	240V	208V	240V	480V	480V	480V	600V	600V	600V
² Maximum Overcurrent Protection (MOCP)	Unit+ Electric Heat	15 kW	125	125	125	150	150	150	60	70	70	50	50	60
		30 kW	175	175	175	200	175	200	90	90	90	70	70	70
		45 kW	200	225	225	225	225	250	110	110	125	90	90	90
		60 kW	225	250	225	250	225	250	110	125	125	90	90	100
³ Minimum Circuit Ampacity (MCA)	Unit+ Electric Heat	15 kW	119	125	125	131	132	138	59	62	66	47	49	52
		30 kW	158	170	164	176	172	184	82	85	88	65	67	70
		45 kW	197	215	203	221	211	229	105	107	111	83	85	88
		60 kW	205	224	211	230	218	238	109	112	115	87	89	92
² Maximum Overcurrent Protection (MOCP)	Unit+ Electric Heat and (2) 0.33 HP Power Exhaust	15 kW	125	150	150	150	150	150	70	70	70	50	60	60
		30 kW	175	175	175	200	200	200	90	90	100	70	70	80
		45 kW	225	225	225	250	225	250	110	110	125	90	90	90
		60 kW	225	250	225	250	250	250	125	125	125	90	100	100
³ Minimum Circuit Ampacity (MCA)	Unit+ Electric Heat and (2) 0.33 HP Power Exhaust	15 kW	124	130	130	136	137	143	62	65	68	49	51	54
		30 kW	163	175	169	181	176	188	85	87	91	67	69	72
		45 kW	202	220	208	226	215	233	107	110	113	85	87	90
		60 kW	210	229	216	235	223	242	112	114	118	89	91	94

NOTE - All units have a minimum Short Circuit Current Rating (SCCR) of 5000 amps.

¹ Extremes of operating range are plus and minus 10% of line voltage.

² HACR type breaker or fuse.

³ Refer to National or Canadian Electrical Code manual to determine wire, fuse and disconnect size requirements.

⁴ Disconnect must be field furnished.

ELECTRICAL/ELECTRIC HEAT DATA

20 TON

Model		LHX240S5M								
¹ Voltage - 60Hz		208/230V - 3 Ph			460V - 3 Ph			575V - 3 Ph		
Compressor 1 (Non-Inverter)	Rated Load Amps	28.5			13.5			10.7		
	Locked Rotor Amps	255			123			93.7		
Compressor 2 (Non-Inverter)	Rated Load Amps	28.5			13.5			10.7		
	Locked Rotor Amps	255			123			93.7		
Outdoor Fan Motors (4)	Full Load Amps (4 Non-ECM)	2.4			1.3			1		
	Total	9.6			5.2			4		
Power Exhaust (2) 0.33 HP	Full Load Amps	2.4			1.3			1		
	Total	4.8			2.6			2		
Service Outlet 115V GFI (amps)		15			15			20		
Indoor Blower Motor	HP	5	7.5	10	5	7.5	10	5	7.5	10
	Full Load Amps	16.7	24.2	30.8	7.6	11	14	6.1	9	11
² Maximum Overcurrent Protection (MOCP)	Unit Only	110	125	125	50	60	60	40	45	50
	With (2) 0.33 HP Power Exhaust	110	125	125	50	60	60	45	45	50
³ Minimum Circuit Ampacity (MCA)	Unit Only	91	98	106	44	47	50	35	38	40
	With (2) 0.33 HP Power Exhaust	96	103	110	46	50	53	37	40	42

ELECTRIC HEAT DATA

Electric Heat Voltage			208V	240V	208V	240V	208V	240V	480V	480V	480V	600V	600V	600V
² Maximum Overcurrent Protection (MOCP)	Unit+ Electric Heat	15 kW	150	150	150	150	150	175	70	70	80	60	60	60
		30 kW	175	200	200	200	200	200	90	100	100	80	80	80
		45 kW	225	250	225	250	225	250	125	125	125	90	100	100
		60 kW	225	250	250	250	250	250	125	125	125	100	100	100
		90 kW	300	350	300	350	300	350	175	175	175	125	125	150
³ Minimum Circuit Ampacity (MCA)	Unit+ Electric Heat	15 kW	130	136	138	144	145	151	66	70	73	53	56	58
		30 kW	169	181	177	189	184	196	89	92	95	71	74	76
		45 kW	208	226	216	234	223	241	111	115	118	89	92	94
		60 kW	216	235	224	243	231	250	116	119	122	92	95	97
		90 kW	279	307	286	315	293	322	152	155	158	121	124	126
² Maximum Overcurrent Protection (MOCP)	Unit+ Electric Heat and (2) 0.33 HP Power Exhaust	15 kW	150	150	150	150	150	175	70	80	80	60	60	60
		30 kW	175	200	200	200	200	225	100	100	100	80	80	80
		45 kW	225	250	225	250	250	250	125	125	125	100	100	100
		60 kW	225	250	250	250	250	300	125	125	125	100	100	100
		90 kW	300	350	300	350	300	350	175	175	175	125	150	150
³ Minimum Circuit Ampacity (MCA)	Unit+ Electric Heat and (2) 0.33 HP Power Exhaust	15 kW	135	141	142	148	149	156	69	72	75	55	58	60
		30 kW	174	186	181	193	189	201	91	95	98	73	76	78
		45 kW	213	231	220	239	228	246	114	117	120	91	94	96
		60 kW	221	240	228	248	235	255	118	122	125	94	97	99
		90 kW	283	312	291	320	298	327	155	158	161	123	126	128

NOTE - All units have a minimum Short Circuit Current Rating (SCCR) of 5000 amps.

¹ Extremes of operating range are plus and minus 10% of line voltage.

² HACR type breaker or fuse.

³ Refer to National or Canadian Electrical Code manual to determine wire, fuse and disconnect size requirements.

⁴ Disconnect must be field furnished.

ELECTRICAL/ELECTRIC HEAT DATA

25 TON

Model		LHX300S5M								
¹ Voltage - 60Hz		208/230V - 3 Ph			460V - 3 Ph			575V - 3 Ph		
Compressor 1 (Non-Inverter)	Rated Load Amps	33.3			15.4			13		
	Locked Rotor Amps	255			140			107.6		
Compressor 2 (Non-Inverter)	Rated Load Amps	33.3			15.4			13		
	Locked Rotor Amps	255			140			107.6		
Outdoor Fan Motors (6)	Full Load Amps (6 Non-ECM)	3			1.5			1.2		
	Total	18			9			7.2		
Power Exhaust (2) 0.33 HP	Full Load Amps	2.4			1.3			1		
	Total	4.8			2.6			2		
Service Outlet 115V GFI (amps)		15			15			20		
Indoor Blower Motor	HP	5	7.5	10	5	7.5	10	5	7.5	10
	Full Load Amps	16.7	24.2	30.8	7.6	11	14	6.1	9	11
² Maximum Overcurrent Protection (MOCP)	Unit Only	125	150	150	60	70	70	50	50	60
	With (2) 0.33 HP Power Exhaust	125	150	150	60	70	70	50	60	60
³ Minimum Circuit Ampacity (MCA)	Unit Only	110	118	124	52	55	58	43	46	48
	With (2) 0.33 HP Power Exhaust	115	122	129	54	58	61	45	48	50

ELECTRIC HEAT DATA

Electric Heat Voltage			208V	240V	208V	240V	208V	240V	480V	480V	480V	600V	600V	600V
² Maximum Overcurrent Protection (MOCP)	Unit+ Electric Heat	15 kW	⁴ 150	175	175	175	175	175	80	80	90	70	70	70
		30 kW	200	200	⁴ 200	225	225	225	100	100	110	80	90	90
		45 kW	250	250	⁴ 250	⁴ 300	⁴ 250	⁴ 300	125	125	150	100	100	110
		60 kW	⁴ 250	⁴ 300	⁴ 250	⁴ 300	⁴ 250	⁴ 300	125	150	150	110	110	110
		90 kW	N/A	N/A	N/A	N/A	N/A	N/A	175	175	175	150	150	150
³ Minimum Circuit Ampacity (MCA)	Unit+ Electric Heat	15 kW	149	155	157	163	163	169	74	78	81	61	64	66
		30 kW	188	200	196	208	202	214	97	100	103	79	82	84
		45 kW	227	245	235	253	241	260	119	123	126	97	100	102
		60 kW	235	254	243	262	249	269	124	127	130	101	104	106
		90 kW	N/A	N/A	N/A	N/A	N/A	N/A	160	163	166	130	133	135
² Maximum Overcurrent Protection (MOCP)	Unit+ Electric Heat and (2) 0.33 HP Power Exhaust	15 kW	175	175	175	175	175	175	80	90	90	70	70	70
		30 kW	⁴ 200	225	225	225	225	225	100	110	110	90	90	90
		45 kW	250	250	⁴ 250	⁴ 300	⁴ 250	⁴ 300	125	125	150	100	110	110
		60 kW	⁴ 250	⁴ 300	⁴ 250	⁴ 300	300	⁴ 300	150	150	150	110	110	110
		90 kW	N/A	N/A	N/A	N/A	N/A	N/A	175	175	175	150	150	150
³ Minimum Circuit Ampacity (MCA)	Unit+ Electric Heat and (2) 0.33 HP Power Exhaust	15 kW	154	160	162	168	168	174	77	80	83	63	66	68
		30 kW	193	205	201	213	207	219	99	103	106	81	84	86
		45 kW	232	250	240	258	246	264	122	125	128	99	102	104
		60 kW	240	259	248	267	254	273	127	130	133	103	106	108
		90 kW	N/A	N/A	N/A	N/A	N/A	N/A	163	166	169	132	135	137

NOTE - All units have a minimum Short Circuit Current Rating (SCCR) of 5000 amps.

¹ Extremes of operating range are plus and minus 10% of line voltage.

² HACR type breaker or fuse.

³ Refer to National or Canadian Electrical Code manual to determine wire, fuse and disconnect size requirements.

⁴ Disconnect must be field furnished.

ELECTRICAL ACCESSORIES - DISCONNECTS

15 TON | LHX180S5

Motor HP	3		5		7.5		3	5	7.5	3	5	7.5
	208V	240V	208V	240V	208V	240V	480V	480V	480V	600V	600V	600V
Unit Only	54W86	54W86	54W86	54W86	54W86	54W86	54W85	54W85	54W85	54W85	54W85	54W85
+ Power Exhaust	54W86	54W86	54W86	54W86	54W86	54W86	54W85	54W85	54W85	54W85	54W85	54W85
+ Electric Heat 15 kW	54W86	54W86	54W86	54W86	54W86	54W86	54W85	54W85	54W85	54W85	54W85	54W85
+ Electric Heat 30 kW	54W87	54W87	54W87	54W87	54W87	54W87	54W85	54W86	54W86	54W85	54W85	54W85
+ Electric Heat 45 kW	54W87	54W87	54W87	54W87	54W87	54W87	54W86	54W86	54W86	54W86	54W86	54W86
+ Electric Heat 60 kW	¹ N/A	54W87	¹ N/A	¹ N/A	¹ N/A	¹ N/A	54W86	54W86	54W86	54W86	54W86	54W86
+ Power Exhaust + Elec. Heat 15 kW	54W86	54W86	54W86	54W86	54W87	54W86	54W85	54W85	54W85	54W85	54W85	54W85
+ Power Exhaust + Elec. Heat 30 kW	54W87	54W87	54W87	54W87	54W87	54W87	54W86	54W86	54W86	54W85	54W85	54W85
+ Power Exhaust + Elec. Heat 45 kW	54W87	54W87	54W87	54W87	54W87	54W87	54W86	54W86	54W86	54W86	54W86	54W86
+ Power Exhaust + Elec. Heat 60 kW	¹ N/A	¹ N/A	¹ N/A	¹ N/A	¹ N/A	¹ N/A	54W86	54W86	54W86	54W86	54W86	54W86

20 TON | LHX240S5

Motor HP	5		7.5		10		5	7.5	10	5	7.5	10
	208V	240V	208V	240V	208V	240V	480V	480V	480V	600V	600V	600V
Unit Only	54W86	54W86	54W86	54W86	54W86	54W86	54W85	54W85	54W85	54W85	54W85	54W85
+ Power Exhaust	54W86	54W86	54W86	54W86	54W86	54W86	54W85	54W85	54W85	54W85	54W85	54W85
+ Electric Heat 15 kW	54W86	54W86	54W87	54W86	54W87	54W87	54W85	54W85	54W85	54W85	54W85	54W85
+ Electric Heat 30 kW	54W87	54W87	54W87	54W87	54W87	54W87	54W86	54W86	54W86	54W85	54W85	54W85
+ Electric Heat 45 kW	54W87	54W87	54W87	54W87	¹ N/A	54W87	54W86	54W86	54W86	54W86	54W86	54W86
+ Electric Heat 60 kW	¹ N/A	¹ N/A	¹ N/A	¹ N/A	¹ N/A	¹ N/A	54W86	54W86	54W86	54W86	54W86	54W86
+ Electric Heat 90 kW	¹ N/A	¹ N/A	¹ N/A	¹ N/A	¹ N/A	¹ N/A	54W87	54W87	54W87	54W86	54W86	54W86
+ Power Exhaust + Elec. Heat 15 kW	54W86	54W86	54W87	54W87	54W87	54W87	54W85	54W85	54W85	54W85	54W85	54W85
+ Power Exhaust + Elec. Heat 30 kW	54W87	54W87	54W87	54W87	54W87	54W87	54W86	54W86	54W86	54W85	54W85	54W85
+ Power Exhaust + Elec. Heat 45 kW	54W87	54W87	N/A	54W87	N/A	54W87	54W86	54W86	54W86	54W86	54W86	54W86
+ Power Exhaust + Elec. Heat 60 kW	¹ N/A	¹ N/A	¹ N/A	¹ N/A	¹ N/A	¹ N/A	54W86	54W86	54W86	54W86	54W86	54W86
+ Power Exhaust + Elec. Heat 90 kW	¹ N/A	¹ N/A	¹ N/A	¹ N/A	¹ N/A	¹ N/A	54W87	54W87	54W87	54W86	54W86	54W86

Disconnects - 54W85 - 80A
 54W86 - 150A
 54W87 - 250A

¹ Disconnect must be field furnished.

FIELD WIRING NOTES

- For use with copper wiring only
- Field wiring not furnished
- All wiring must conform to NEC or CEC and local electrical codes
- For specific wiring information, please refer to the installation instructions

ELECTRICAL ACCESSORIES - DISCONNECTS

25 TON | LHX300S5

Motor HP	5		7.5		10		5	7.5	10	5	7.5	10
	208V	240V	208V	240V	208V	240V	480V	480V	480V	600V	600V	600V
Unit Only	54W86	54W86	54W86	54W86	54W86	54W86	54W85	54W85	54W85	54W85	54W85	54W85
+ Power Exhaust	54W86	54W86	54W86	54W86	54W86	54W86	54W85	54W85	54W85	54W85	54W85	54W85
+ Electric Heat 15 kW	54W87	54W87	54W87	54W87	54W87	54W87	54W85	54W85	54W86	54W85	54W85	54W85
+ Electric Heat 30 kW	54W87	54W87	54W87	54W87	54W87	54W87	54W86	54W86	54W86	54W85	54W86	54W86
+ Electric Heat 45 kW	¹ NA	54W87	¹ NA	54W87	¹ NA	¹ NA	54W86	54W86	54W86	54W86	54W86	54W86
+ Electric Heat 60 kW	¹ NA	¹ NA	¹ NA	¹ NA	¹ NA	¹ NA	54W86	54W86	54W86	54W86	54W86	54W86
+ Electric Heat 90 kW	¹ NA	¹ NA	¹ NA	¹ NA	¹ NA	¹ NA	54W87	54W87	54W87	54W86	54W86	54W87
+ Power Exhaust + Elec. Heat 15 kW	54W87	54W87	54W87	54W87	54W87	54W87	54W85	54W86	54W86	54W85	54W85	54W85
+ Power Exhaust + Elec. Heat 30 kW	54W87	54W87	54W87	54W87	54W87	54W87	54W86	54W86	54W86	54W86	54W86	54W86
+ Power Exhaust + Elec. Heat 45 kW	¹ NA	54W87	¹ NA	¹ NA	¹ NA	¹ NA	54W86	54W86	54W86	54W86	54W86	54W86
+ Power Exhaust + Elec. Heat 60 kW	¹ NA	¹ NA	¹ NA	¹ NA	¹ NA	¹ NA	54W86	54W86	54W86	54W86	54W86	54W86
+ Power Exhaust + Elec. Heat 90 kW	¹ NA	¹ NA	¹ NA	¹ NA	¹ NA	¹ NA	54W87	54W87	54W87	54W86	54W87	54W87

Disconnects - 54W85 - 80A
 54W86 - 150A
 54W87 - 250A

¹ Disconnect must be field furnished.

ELECTRIC HEAT CAPACITIES

Volts Input	15 kW			30 kW			45 kW			60 kW			90 kW		
	kW Input	Btuh Output	No. of Stages	kW Input	Btuh Output	No. of Stages	kW Input	Btuh Output	No. of Stages	kW Input	Btuh Output	No. of Stages	kW Input	Btuh Output	No. of Stages
208	11.3	38,600	1	22.5	76,800	1	33.8	115,300	1	45.0	153,600	1	N/A	N/A	N/A
220	12.6	43,000	1	25.2	86,000	1	37.8	129,000	1	50.4	172,000	1	N/A	N/A	N/A
230	13.8	47,100	1	27.5	93,900	1	41.3	141,000	1	55.1	188,000	1	N/A	N/A	N/A
240	15.0	51,200	1	30.0	102,400	1	45.0	153,600	1	60.0	204,800	1	N/A	N/A	N/A
440	12.6	43,000	1	25.2	86,000	1	37.8	129,000	1	50.4	172,000	1	75.6	258,000	1
460	13.8	47,100	1	27.5	93,900	1	41.3	141,000	1	55.1	188,000	1	82.7	282,200	1
480	15.0	51,200	1	30.0	102,400	1	45.0	153,600	1	60.0	204,800	1	90.0	307,100	1
550	12.6	43,000	1	25.2	86,000	1	37.8	129,000	1	50.4	172,000	1	75.6	258,000	1
575	13.8	47,100	1	27.5	93,900	1	41.3	141,000	1	55.1	188,000	1	82.7	282,200	1
600	15.0	51,200	1	30.0	102,400	1	45.0	153,600	1	60.0	204,800	1	90.0	307,100	1

Minimum R454B Space and CFM Requirements

Minimum Airflow ¹		
Unit	Q _{min} (CFM)	Q _{min} (m ³ h)
LHX180	595	1010
LHX240	582	988
LHX300	587	997

¹ **NOTE** - The minimum airflow is the lowest CFM allowed during venting operation (leak mitigation).

Refrigerant Charge R-454B		
Unit	M _c (lbs)	M _c (kg)
LHX180 circuit 1	22.50	10.21
LHX180 circuit 2	20.20	9.16
LHX240 circuit 1	22.00	9.98
LHX240 circuit 2	21.50	9.75
LHX300 circuit 1	22.20	10.07
LHX300 circuit 2	21.00	9.53

Minimum Room Area of Conditioned Space ²		
Unit	TA _{min} (ft ²)	TA _{min} (m ²)
LHX180	330	30.62
LHX240	323	29.94
LHX300	326	30.21

² **NOTE** - The minimum room area of conditioned space is the smallest area the unit can service.

Altitude Adjustment Factor ³									
Halt	0	200	400	600	800	1000	1200	1400	1600
AF	1	1	1	1	1.02	1.05	1.04	1.1	1.12
Halt	1600	1800	2000	2200	2400	2600	2800	3000	3200
AF	1.12	1.15	1.18	1.21	1.25	1.28	1.32	1.36	1.40

³ **NOTE** - Use the Altitude Adjustment Factor to adjust the values in the tables above to different altitudes. Find the relevant altitude above sea level in the two "Halt" rows and then multiply the value needed from the tables above by the altitude factor number. Example: For the minimum airflow in CFM for an LHX180 at 1000 ft. above sea level, multiply 595 by 1.05 to get 624.75 CFM as the new Q_{min}.

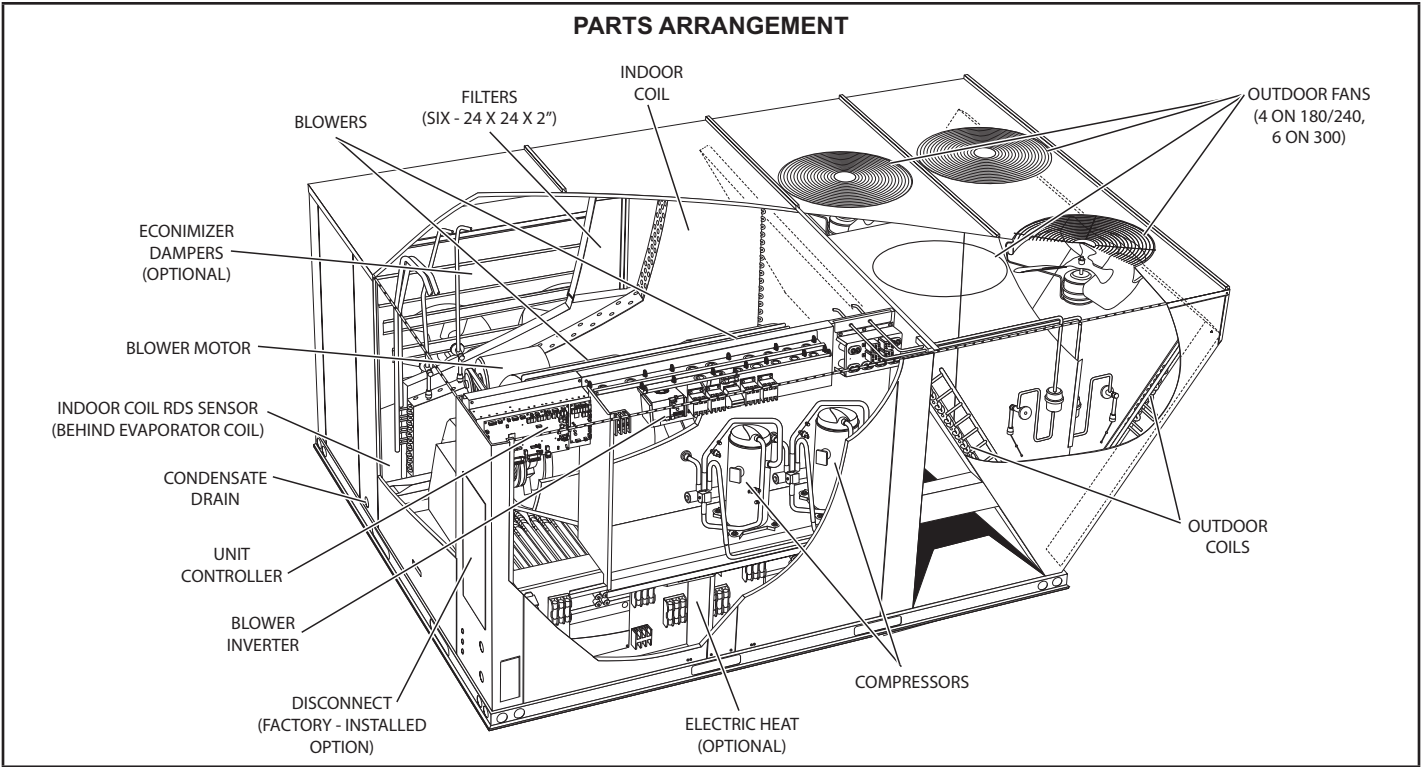

FIGURE 1

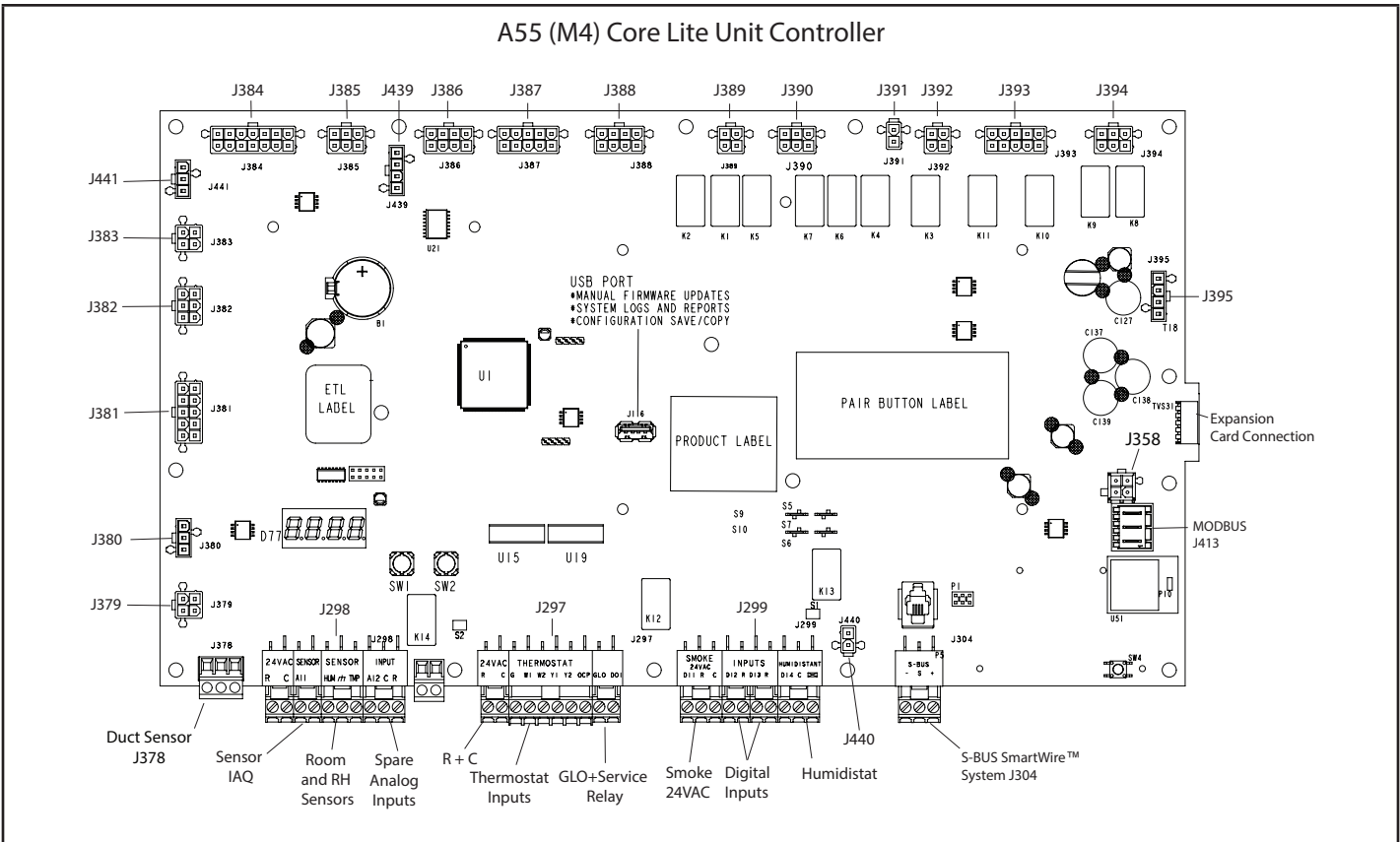

FIGURE 2

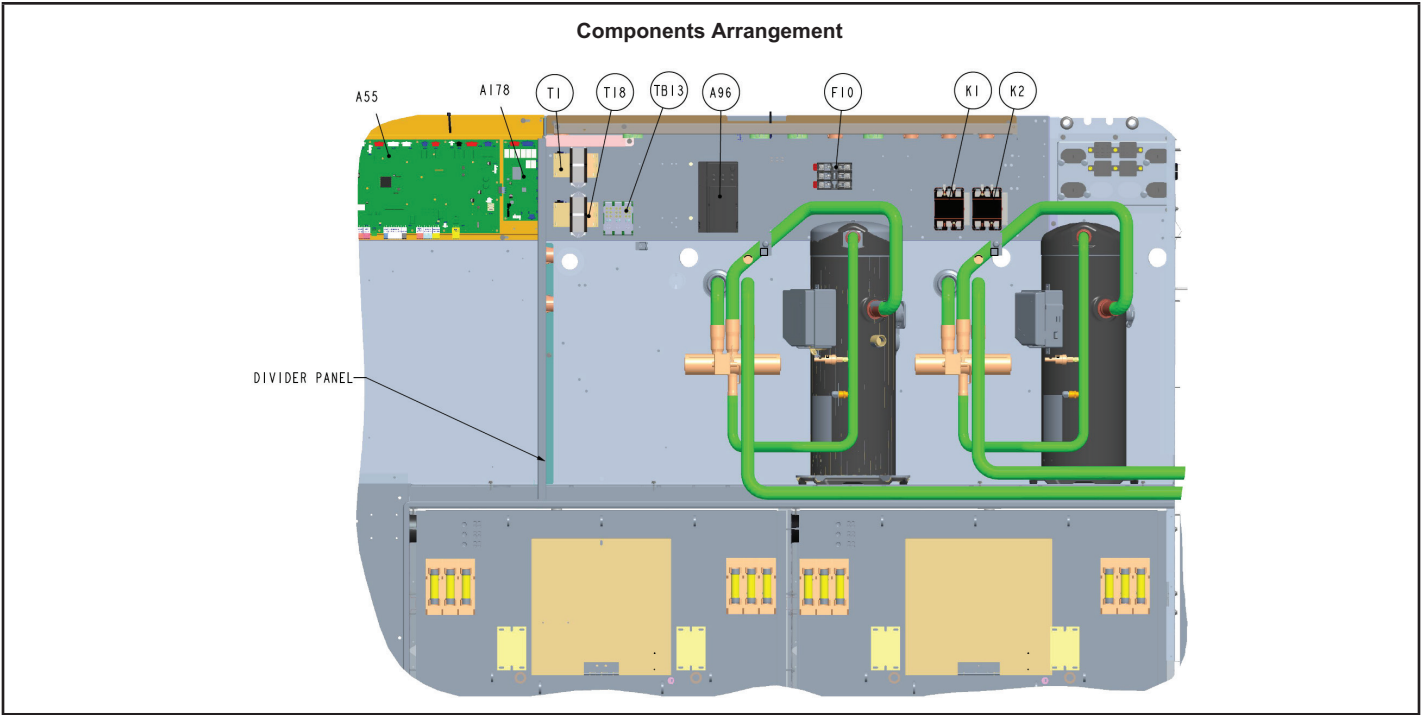

FIGURE 3

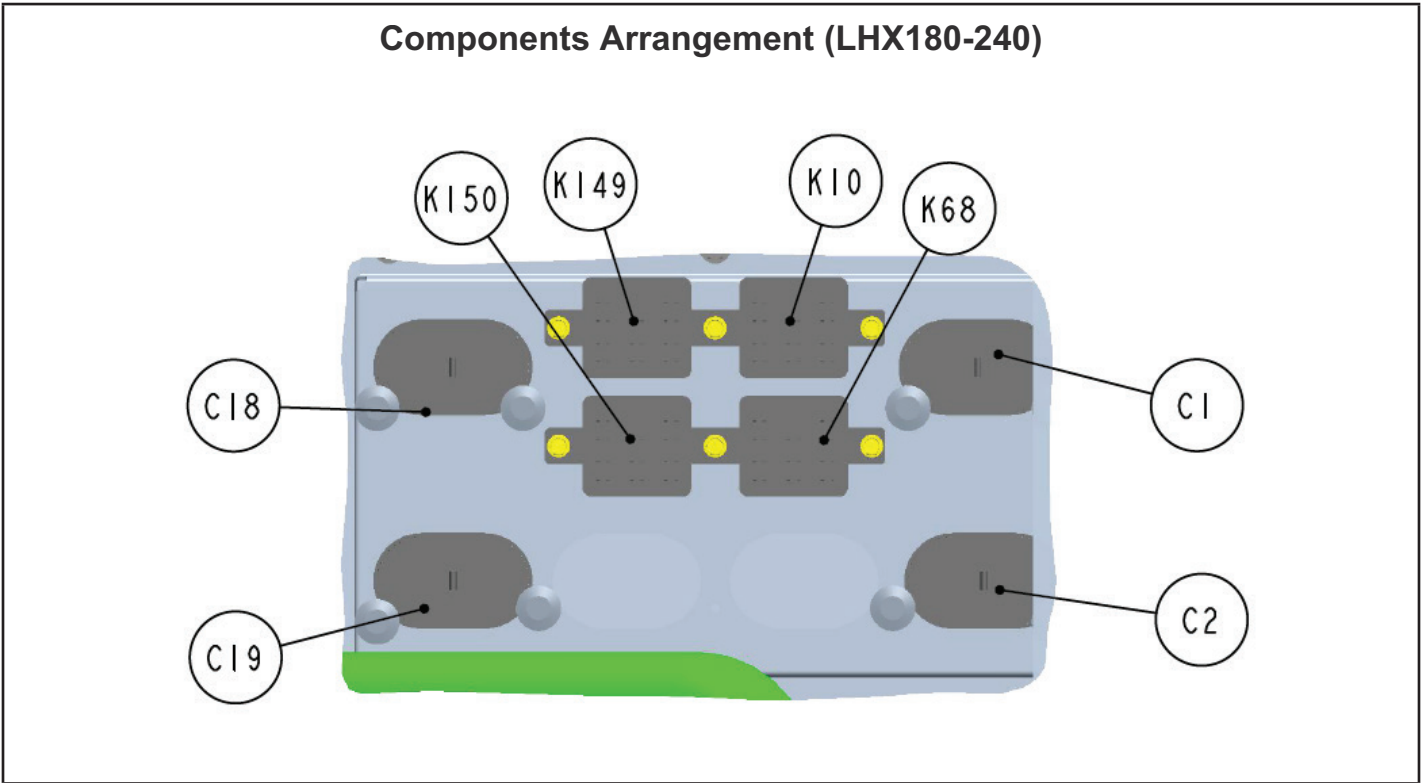

FIGURE 4

Components Arrangement (LHX300)

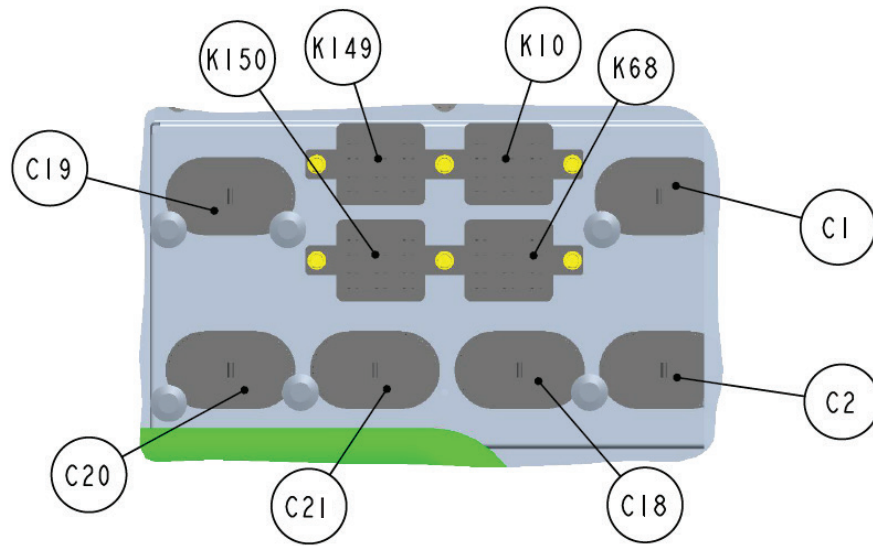

FIGURE 5

I-UNIT COMPONENTS

All 15 through 25 ton units are configured to order units (CTO). Unit components are shown in FIGURE 1. All L1, L2 and L3 wiring is color coded; L1 is red, L2 is yellow and L3 is blue.

⚠ CAUTION

As with any mechanical equipment, contact with sharp sheet metal edges can result in personal injury. Take care while handling this equipment and wear gloves and protective clothing.

**ELECTROSTATIC DISCHARGE (ESD)
Precautions and Procedures**

⚠ CAUTION

Electrostatic discharge can affect electronic components. Take precautions to neutralize electrostatic charge by touching your hand and tools to metal prior to handling the control.

A-Control Box Components

Control box components are shown in FIGURE 3, FIGURE 4 & FIGURE 5. The control box is located in the upper portion of the compressor compartment.

1-Disconnect Switch S48

Units may be equipped with a disconnect switch, S48, a toggle or twist-style switch, which can be used by the service technician to disconnect power to the unit.

2-Control Transformer T1

All use a single line voltage to 24VAC transformer mounted in the control box. Transformer supplies power to control circuits in the unit. The transformer is rated at 70VA and is protected by a 3.5 amp circuit breaker (CB8). The 208/230 (Y) voltage transformers use two primary voltage taps as shown in FIGURE 6, while 460 (G) and 575 (J) voltage transformers use a single primary voltage tap.

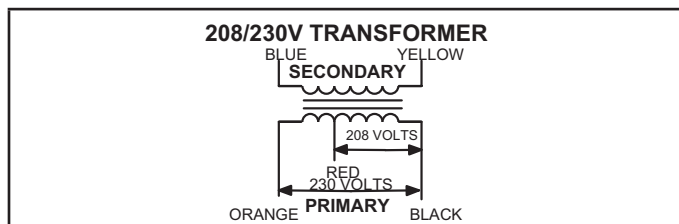

FIGURE 6

3-Contactor Transformer T18

T18 is a single line voltage to 24VAC transformer used in all LHX 15 to 25 ton units. Transformer T18 is protected by a 3.5 amp circuit breaker (CB18). T18 is identical to transformer T1. The transformer supplies 24VAC power to the contactors. 4-Terminal Block TB13

TB13 terminal block distributes line voltage power to the line voltage items in the unit.

5-Outdoor Fan Motor Fuse Block & Fuses

F10 Power Exhaust Fan Motor Fuse Block and Fuses F6. STD SCCR 240V, 300V and higher rated SCCR units have three line voltage fuses F10 provide overcurrent protection to all condenser fans. Two line voltage fuses F6 provide overcurrent protection to the two optional power exhaust fans. The fuses are rated at 30A in all 208/230V units but 10A in the 208/230V 240U and 300U models.

6-Compressor Contactor K1 and K2

All compressor contactors are three-pole-double-break contactors with 24VAC coils. In all units, K1 (energized by A55) energizes compressors B1 in response to first stage cool demand, and K2 (energized by A55) energizes B2 in response to second stage cool demand.

7-Ultraviolet Germicidal Lamp (UVC) Transformer T49

UVC transformer T49 is used in 460V and 575V units which are equipped with a UVC. The auto voltage to 230VAC transformer is installed in the control box. The transformer has an output rating of 0.5 amps. T49 transformer supplies 230VAC power to the UVC lamp.

8-Power Exhaust Relay K65 & K231 (PED units)

Power exhaust relays K65 and K231 are N.O. DPDT relays with a 24VAC coil. The relays are used in units equipped with the optional power exhaust dampers. K65 and K231 are energized by the A55 Unit Controller, after the economizer dampers reach 50% open (adjustable in ECTO). When K65 closes, exhaust fan B10 is energized and when K231 closes B11 is energized.

9-Variable Frequency Drive A96

Staged-Blower units are equipped with a VFD which alters the supply power frequency and voltage to the blower motor. Blower speed is staged depending on the compressor stages, heating demand, ventilation demand, or smoke alarm. The amount of airflow for each stage is preset from the factory. Airflow can be adjusted by changing ECTO parameters in the A55 Unit Controller. The VFD is located below the Unit Controller.

10-VFD Power To Motor Contactor K202 (optional)

Contactor is used in Staged-Blower units equipped with a VFD bypass option. The three pole 40 amp contactor with a 24VAC coil is energized by the A55 Unit Controller. K202 allows power from the VFD to the B3 blower motor in response to blower demand.

11-Inverter Start Forward Rotation Relay K203

Relay is used in staged-blower units and is a three-pole double-throw relay with a 24VAC coil. K203 is energized by the A55 Unit Controller and provides input to the A96 VFD to start blower forward rotation.

12-Unit Controller A55

The Unit Controller provides all unit control functions, unit status information, unit diagnostics, programmable parameters and USB verification and profile sharing. Refer to the Unit Controller guide provided with the unit. Thermostat wires are connected to J297 on the Unit Controller.

Relative Humidity Sensor - Optional

The indoor relative humidity sensor (A91) is an analog sensor with a 0-10VDC output over a relative humidity range of 0-100% relative humidity. The sensor is powered with 24VAC.

Enthalpy Sensor - Optional

The optional enthalpy sensors (A7 and A63) used with the economizer have an output of 4-20mA. The sensor is powered with 18VAC provided by M4 unit control.

Temperature Sensors

The return air (RT16) and discharge air (RT6) duct probes and the outdoor air (RT17) are all two wire thermistors. The resistance vs. temperature table is shown below:

TABLE 1
Resistance vs. Temperature

Temp. °F (°C)	Resistance +/-2%	Temperature °F (°C)	Resistance +/-2%	Temp. °F (°C)	Resistance +/-2%
-40 (-40)	335,671	40 (4.4)	26,106	90 (32.2)	7,332
-20 (-28.9)	164,959	50 (10)	19,904	100 (37.8)	5,826
0 (-17.8)	85,323	60 (15.6)	15,313	120 (48.9)	3,756
20 (-6.7)	46,218	70 (21.1)	11,884	130 (54.4)	3,047
30 (-1.1)	34,566	80 (26.7)	9,298		

Room Sensors

Room sensor (A2) is a two-wire thermistor with 1k series resistor.

TABLE 2
Two-Wire Thermistor

Temp. °F (°C)	Resistance +/-2%	Temperature °F (°C)	Resistance +/-2%	Temp. °F (°C)	Resistance +/-2%
40 (4.4)	27,102	60 (15.6)	16,313	80 (26.7)	10,299
45 (7.2)	23,764	65 (18.3)	14,474	85 (29.4)	9,249
50 (10)	20,898	70 (21.1)	12,882	90 (32.2)	8,529
55 (12.8)	18,433	75 (23.9)	11,498		

Carbon Dioxide Sensor

The indoor carbon dioxide sensor (A63) is an analog sensor with a 0-10VDC output over a carbon dioxide range of 0-2000 ppm as shown in the following table. The sensor is powered with 24VAC.

TABLE 3
Carbon Dioxide Range

Carbon Dioxide PPM	DC Voltage	Carbon Dioxide PPM	DC Voltage	Carbon Dioxide PPM	DC Voltage	Carbon Dioxide PPM	DC Voltage
0	0	600	3	1200	6	1800	9
200	1	800	4	1400	7	2000	10
400	2	1000	5	1600	8		

13-Second-Stage Power Exhaust Relay K231 (Staged-Blower units equipped with power exhaust)

The second power exhaust fan is controlled by K231. A133 will enable K231 only when the blower reaches 70% of full speed (adjustable ECTO). This prevents a negative building pressure when the blower is operating in low speed. Refer to the Unit Controller manual and ECTO labels on the unit.

14-Fuse F61 (Higher SCCR units only)

Fuse F61 is used on units with higher SCCR rating. F61 provides overcurrent protection to compressor and other cooling components. F61 and S48 are located inside a sheet metal enclosure in the unit left front corner mullion.

15-Blower Motor Overload Relay S42

The relay (S42) is connected in line with the blower motor to monitor the current flow to the motor. When the relay senses an overload condition, a set of normally closed contacts open to de-energize pin #1 in plug P299 of the A55 Unit Controller. A55 de-energizes all outputs. Units will be equipped with a relay manufactured by Telemecanique FIGURE 7 or Siemens FIGURE 8.

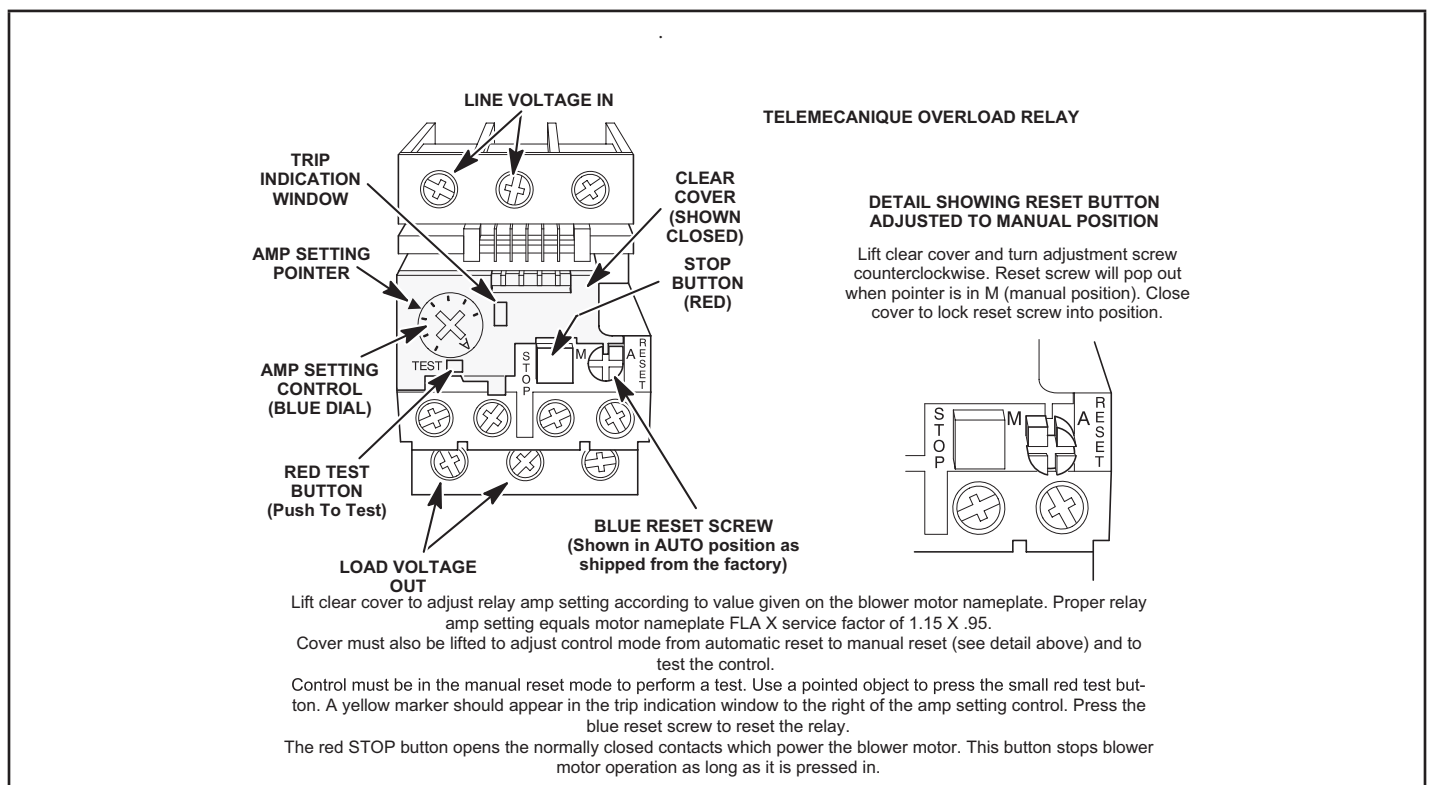
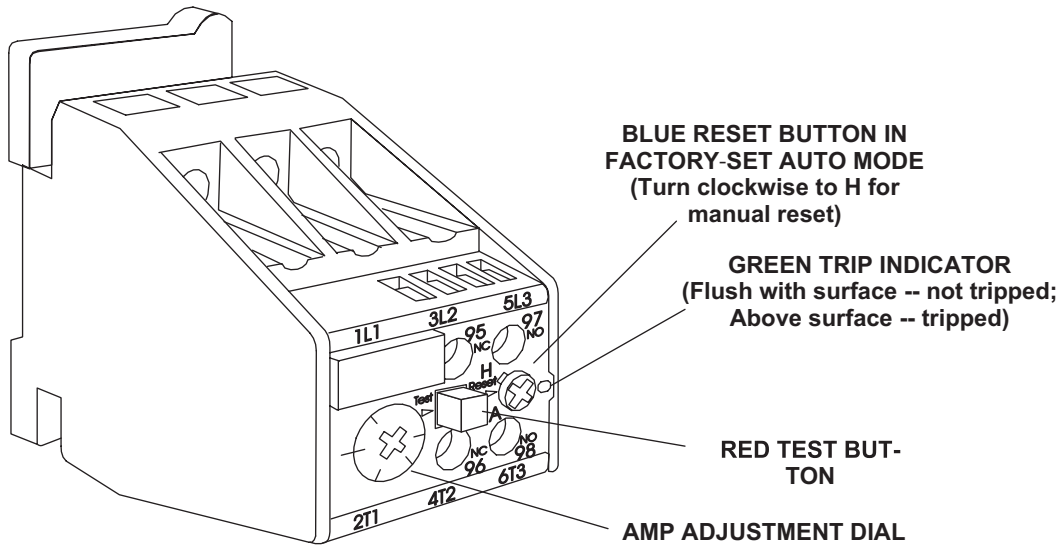

FIGURE 7

SIEMENS OVERLOAD RELAY



Adjust relay amp setting according to value given on the blower motor nameplate. Proper relay amp setting equals motor nameplate FLA X service factor of 1.15 X .95.

Use small slotted screwdriver to adjust control mode from automatic reset (A) to manual reset (H). Control must be in the manual reset mode (H) to perform a test. Press the red test button. Green trip indicator should pop out. Press the blue reset screw to reset the relay.

FIGURE 8

Compressor Detail B1, B2

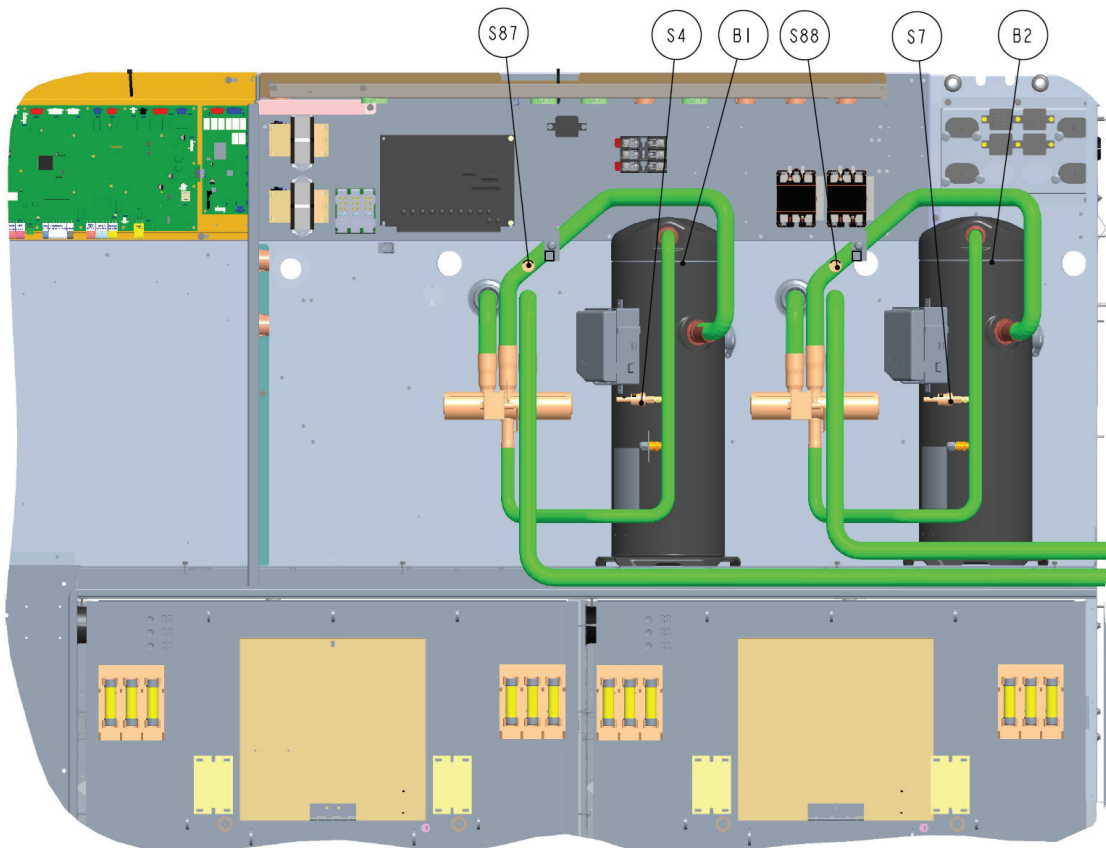

FIGURE 9

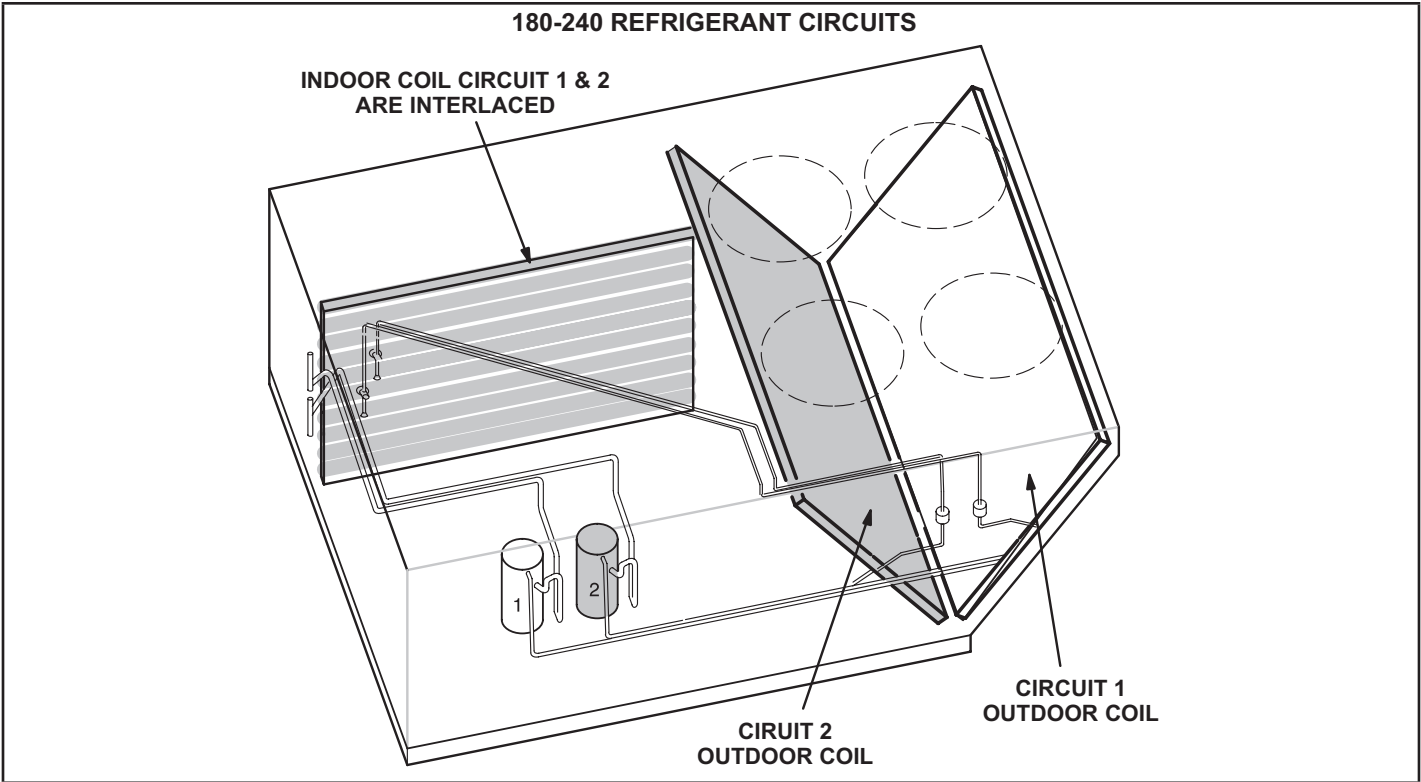

FIGURE 10

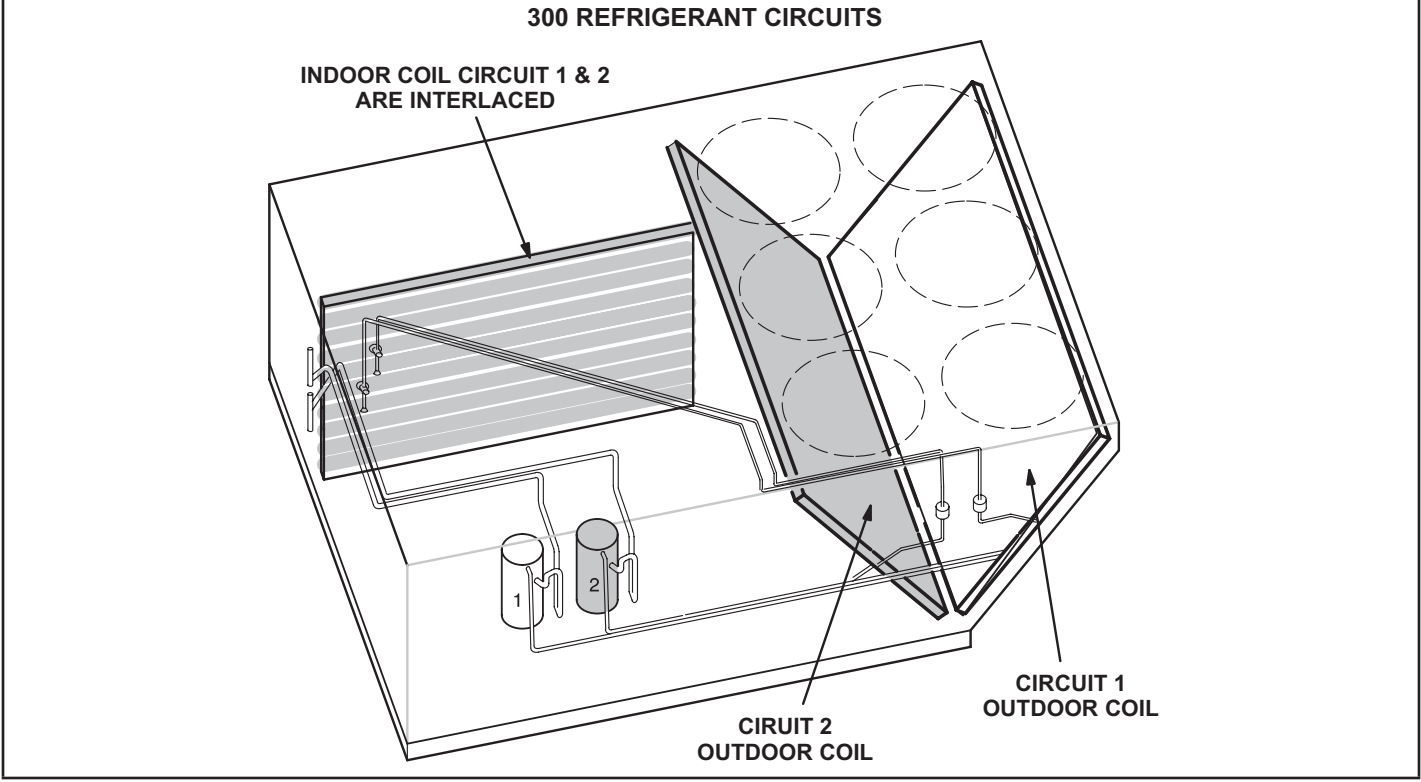

FIGURE 11

B-Cooling Components

Units use independent cooling circuits consisting of one compressor, one condenser coil, and one evaporator coil per circuit.

Four draw-through type condenser fans are used in LHX180 & 240. Six draw-through type condenser fans are used in LHX300 units.

Cooling may be supplemented by a factory- or field-installed economizer. All units have intertwined evaporators. Each evaporator uses a thermostatic expansion valve as the primary expansion device. Each evaporator is also equipped with enhanced fins and rifled tubing. In all units each compressor is protected by a crankcase heater, high pressure switch and low pressure switch.

1-Compressors B1 and B2

All units use scroll compressors. All units use 2 fixed-speed compressors. Compressor capacity may vary from stage to stage. In all cases, the capacity of each compressor is added to reach the total capacity of the unit. See "SPECIFICATIONS" and "ELECTRICAL DATA" (table of contents) or compressor nameplate for compressor specifications.

WARNING

Electrical shock hazard. Compressor must be grounded. Do not operate without protective cover over terminals. Disconnect power before removing protective cover. Discharge capacitors before servicing unit. Failure to follow these precautions could cause electrical shock resulting in injury or death.

Each compressor is energized by a corresponding compressor contactor.

NOTE-Refer to the wiring diagram section for specific unit operation.

If a compressor replacement is necessary, call 1-800-453-6669.

IMPORTANT

Some scroll compressors have an internal vacuum protector that will unload scrolls when suction pressure goes below 20 psig. A hissing sound will be heard when the compressor is running unloaded. Protector will reset when low pressure in system rises above 40 psig. DO NOT REPLACE COMPRESSOR.

2-Crankcase Heaters HR1 and HR2

All LHX units use insertion type heaters. Heater HR1 is installed around compressor B1 and HR2 compressor B2.

3-High Pressure Switches S4 and S7

The high pressure switches is an auto-reset SPST N.C. switch which opens on a pressure rise. All units are equipped with this switch. The switch is located in the compressor discharge line and is wired in series with the compressor contactor coil through A55 unit controller.

S4 and S7 are is wired in series with B1 and B2 compressor contactors.

When discharge pressure rises to 640 ± 10 psig (indicating a problem in the system) the switch opens and the respective compressor(s) is de-energized (the economizer can continue to operate). When discharge pressure drops to 475 ± 20 psig the pressure switch will close re-energizing the compressor(s).

Main control A55 has a three-strike counter before locking out. This means the control allows three high pressure trips per one thermostat demand. The control can be reset by breaking and remaking the thermostat demand or manually resetting the control

4-Low Pressure Switches S87 and S88

The low pressure switch is an auto-reset SPST N.O. switch (held N.C. by refrigerant pressure) which opens on a pressure drop. All units are equipped with this switch. The switch is located in the compressor suction line. See FIGURE 9.

S87 and S88 (compressor one and two) are wired in series with the contactor coils through the A55 Unit Controller

The Unit Controller A55 governs the low pressure switches by shunting the switches during start up until pressure is stabilized. After the shunt period, the control has a three-strike counter, during a single thermostat demand, before the compressor(s) is locked out. The control is reset by breaking and remaking the thermostat demand or manually resetting the control.

When suction pressure drops to 25 ± 5 psig (indicating low pressure), the switch opens and the compressor(s) is de-energized. The switch automatically resets when pressure in the suction line rises to 40 ± 5 psig.

5-Defrost Control

The defrost control ensures that the heat pump outdoor coil does not ice excessively during the heating mode. The defrost control uses input from the coil and ambient sensor to initiate demand defrost cycles from the M4 Board. If the system fails to calibrate or obtain readings for demand defrost, defrost will run-time at field setting. Electric heat is energized during defrost.

6-Filter Drier (all units)

Units have a filter drier located in the liquid line of each refrigerant circuit at the exit of each condenser coil. The drier removes contaminants and moisture from the system.

7-Condenser Fans

B4, B5, B21, B22 (LHX180/240)

B4, B5, B21, B22, B23, B24 (LHX300)

See SPECIFICATIONS tables at the front of this manual for specifications of condenser fans used in all units. All condenser fans used have single-phase motors. The fan assembly may be removed for servicing and cleaning.

8-Reversing Valve

A refrigerant reversing valve with a 24 volt solenoid coil is used to reverse refrigerant flow during unit operation in all units. The reversing valve is connected in the vapor line of the refrigerant circuit. The reversing valve coil is energized during cooling demand and during defrost. Reversing valve L1 & L2 are controlled by the A55 Control board in response to a cooling demand or by defrost.

9-Temperature Thermistor

Units are equipped with four factory-installed thermistors (RT46 - RT49) located on different points on the refrigerant circuit.

The thermistors provide the Unit Controller with constant temperature readings of four specific locations on the refrigeration circuit. These temperatures are used as feedback in certain modes of unit operation. In addition, the Unit Controller uses these temperatures to initiate alarms such as loss of outdoor or indoor coil airflow and loss of charge.

Each thermistor must be specifically placed for proper unit operation and to initiate valid alarms. See FIGURE 12 for indoor coil location. See FIGURE 13 (LHX180/240) and FIGURE 14 (LHX300) for outdoor coil location.

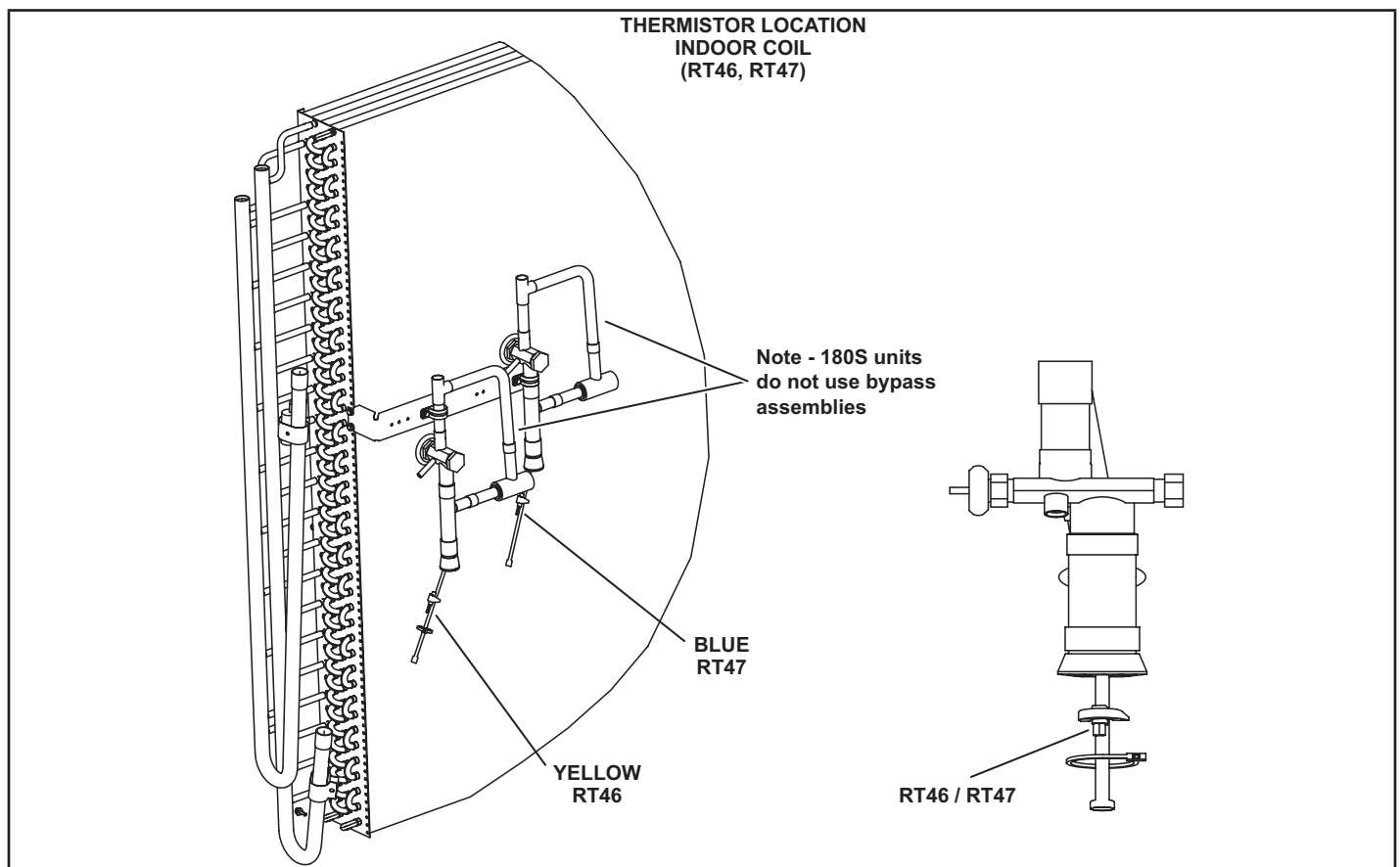

FIGURE 12

THERMISTOR LOCATION
OUTDOOR COIL (LHX180-240)
RT48, RT49

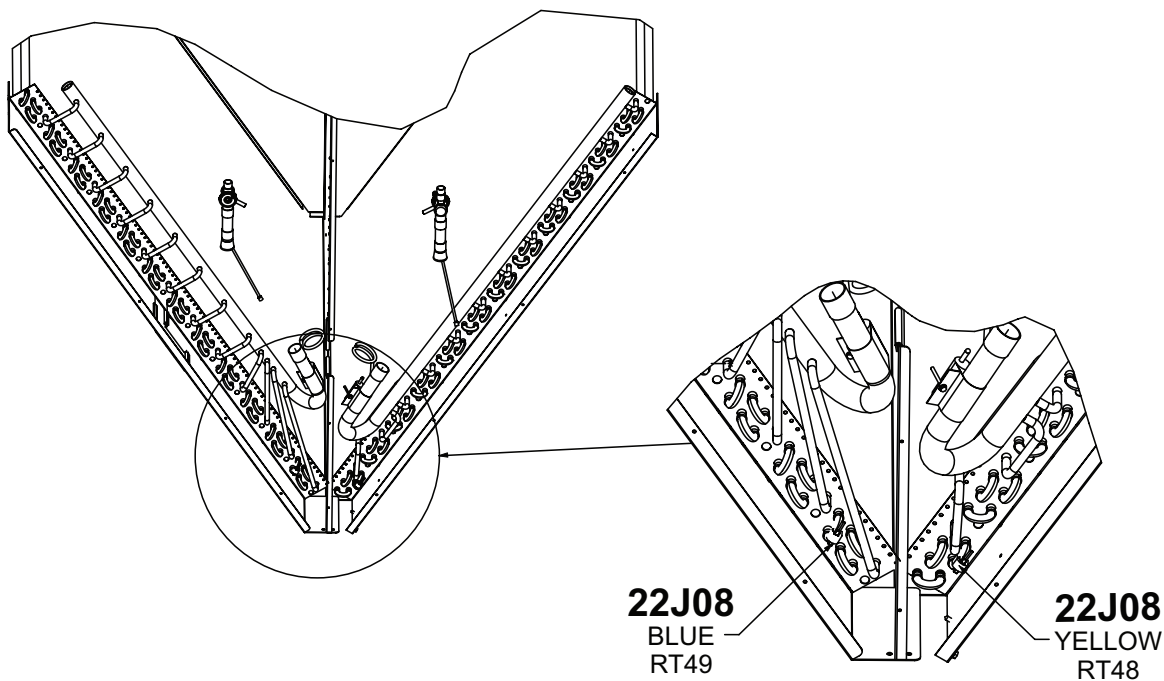

FIGURE 13

THERMISTOR LOCATION
OUTDOOR COIL (LHX300)
RT48, RT49

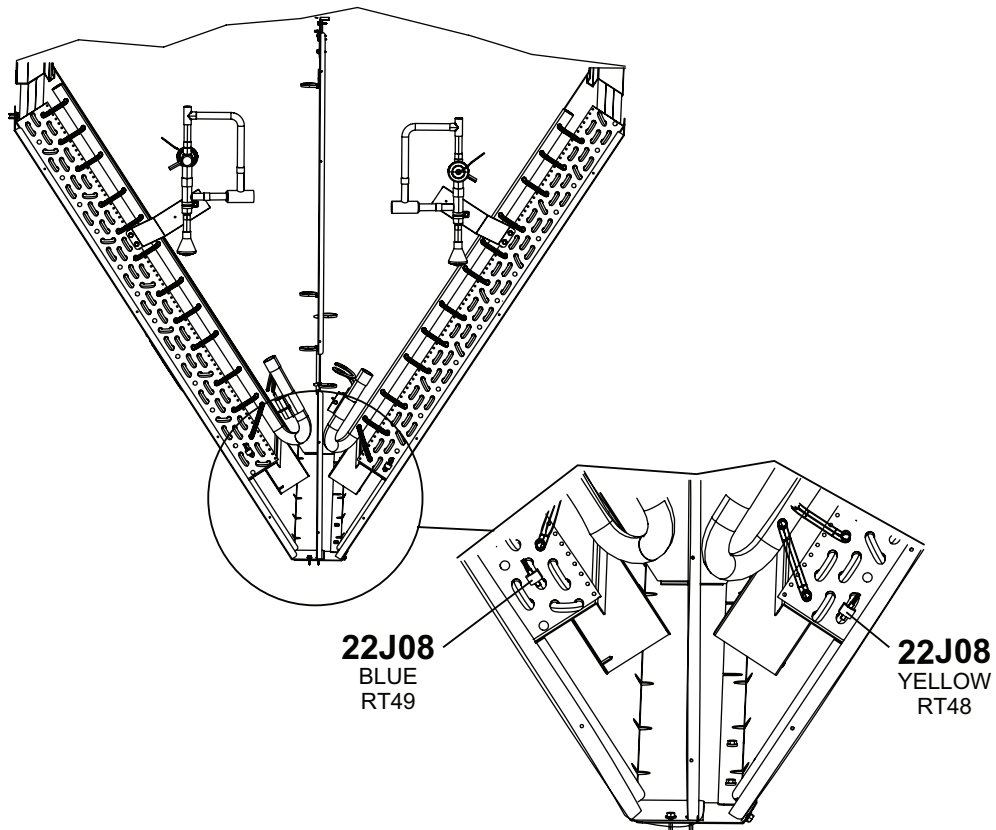

FIGURE 14

10-RDS Sensors

Units are equipped with factory-installed RDS Sensors located on different points on the unit. The RDS sensors provide the Unit Controller with continuous readings for leaked refrigerant concentration levels and sensor health status (Good or Fault). These readings are used to modify unit operation to disperse the leaked refrigerant and to remove possible ignition sources.

In addition, the Unit Controller uses these readings to initiate alarms to alert the operator of a refrigerant leak or faulty sensor(s). Each sensor must be specifically placed for proper unit operation and to initiate valid alarms (see TABLE 4). FIGURE 15 and FIGURE 16 show sensor locations.

TABLE 4 - RDS Alarms

Alarm	Alarm description	RDS Sensor Location
257	Refrigerant leak sensor fault in the Indoor section (sensor #1)	Indoor compartment
258	Refrigerant leak sensor fault in the control panel/compressor section (sensor #2)	"Control/Compressor or Compressor compartment"

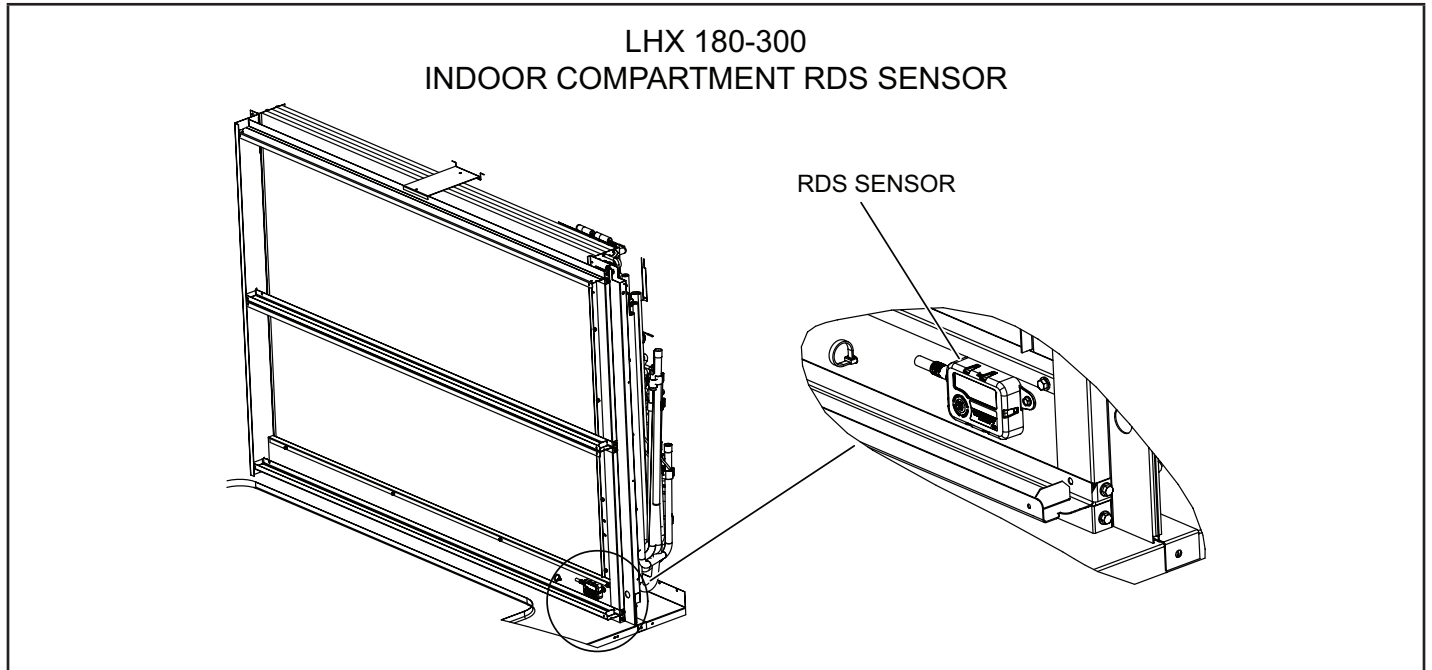

FIGURE 15

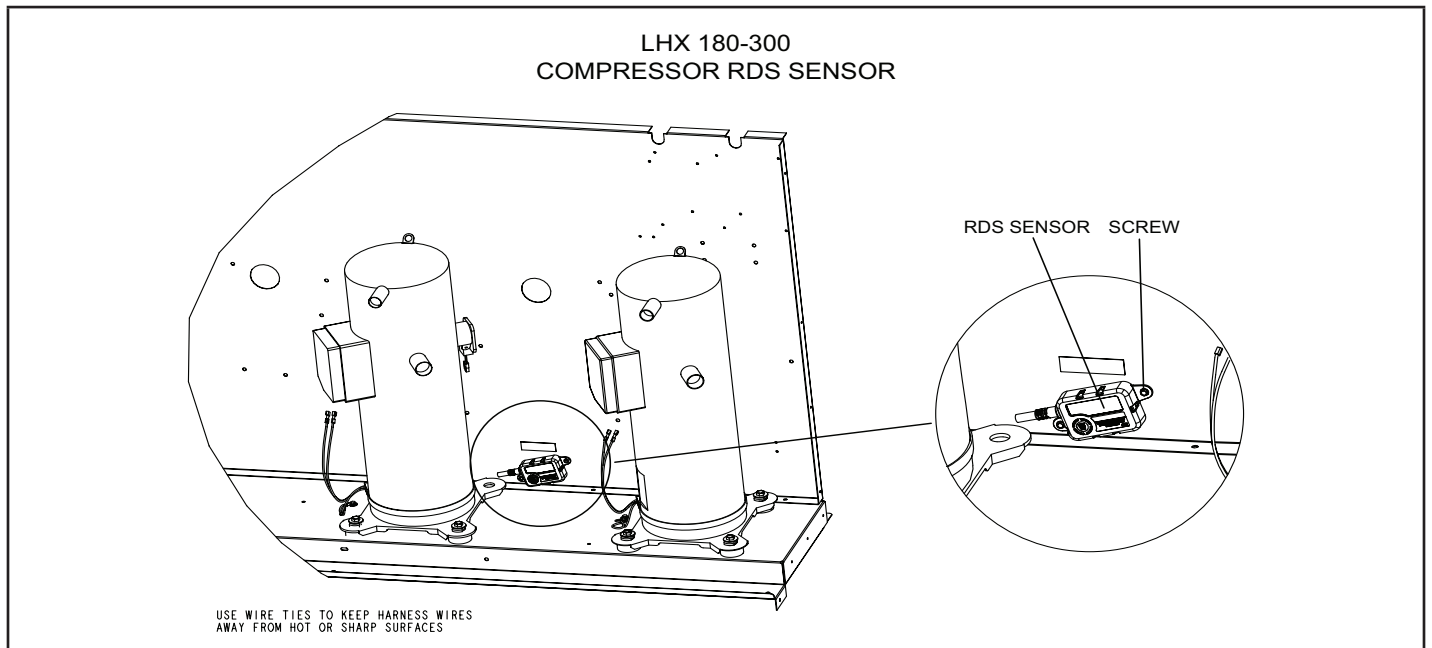
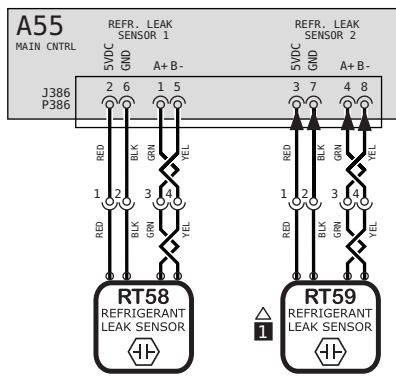

FIGURE 16

RDS SENSOR WIRING DIAGRAM



← DENOTES OPTIONAL COMPONENTS AND WIRING

KEY LIST	
COMPONENT DESCRIPTION	
A55	CONTROL BOARD, MAIN
RT58	SENSOR 1, REFR. LEAK DETECTION
RT59	SENSOR 2, REFR. LEAK DETECTION

NOTES	
1	REFRIGERANT LEAK SENSOR 2 (RT59), MAY NOT BE PRESENT IN ALL UNITS.

WARNING
 DISCONNECT ALL POWER BEFORE SERVICING.
 ELECTRIC SHOCK HAZARD, CAN CAUSE INJURY OR DEATH, UNIT MUST BE GROUNDED IN ACCORDANCE WITH NATIONAL AND LOCAL CODES.
 FOR USE WITH COPPER CONDUCTORS ONLY, REFER TO UNIT RATING PLATE FOR MINIMUM CIRCUIT AMPACITY AND MAXIMUM OVERCURRENT PROTECTION SIZE.
 IF ANY WIRE IN THIS APPLIANCE IS REPLACED, IT MUST BE REPLACED WITH WIRE OF LIKE SIZE, RATING AND INSULATION THICKNESS.

MODEL: Units w/CORE Contr.
 Refr. Leak Detection
 VOLT: All
 SUPSDS: N/A NO: 538440-01

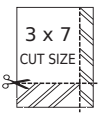

REV	EC NO.	DATE	BY	APVD	REVISION NOTE
---	CN-012295C	04-03-2024	MXR6	MXT5	ORIGINATED AT PD&R CARROLLTON, TX

FIGURE 17

C-Blower Compartment

The blower compartment is located between the evaporator coil and the compressor / control section on the opposite side of the condenser coil. The blower assembly is accessed by disconnecting the blower motor wiring (and all other plugs) and removing the screws on either side of the sliding base. The base pulls out as shown in FIGURE 19.

1-Blower Wheels

All units have two 15 in. x 15 in. blower wheels. Both wheels are driven by one motor.

2-Indoor Blower Motor B3

All units use three-phase single-speed blower motors. CFM adjustments are made by adjusting the motor pulley (sheave). Motors are equipped with sealed ball bearings. All motor specifications are listed in the SPECIFICATIONS (table of contents) in the front of this manual. Units may be equipped with motors manufactured by various manufacturers, therefore electrical FLA and LRA specifications will vary. See unit rating plate for information specific to your unit.

OPERATION / ADJUSTMENT

Supply Air Staged Units - The blower rotation will always be correct on units equipped with an inverter. Checking blower rotation is not a valid method of determining voltage phasing for incoming power. **Supply Air Staged Units and Units Equipped With Optional Voltage or Phase Detection** - The Unit Controller checks the incoming power during start-up. If the voltage or phase is incorrect, the Unit Controller will display an alarm and the unit will not start.

A-Blower Operation

Refer to the Unit Controller Setup Guide to energize blower. Use this mobile service app (the QR is located in the control area) menu:

SERVICE > TEST > BLOWER

Instructions provided with the thermostat may also be used to initiate blower only (G) demand. Unit will cycle on thermostat demand. The following steps apply to applications using a typical electro-mechanical thermostat.

- 1 - Blower operation is manually set at the thermostat subbase fan switch. With fan switch in **ON** position, blowers will operate continuously.
- 2 - With fan switch in **AUTO** position, the blowers will cycle with demand. Blowers and entire unit will be off when system switch is in **OFF** position.

IMPORTANT

Three Phase Scroll Compressor Voltage Phasing

Three phase scroll compressors must be phased sequentially to ensure correct compressor and blower* rotation and operation. Compressor and blower are wired in phase at the factory. Power wires are color-coded as follows: line 1-red, line 2-yellow, line 3-blue.

1-Observe suction and discharge pressures and blower* rotation on unit start-up.

2-Suction pressure must drop, discharge pressure must rise and blower* rotation must match rotation marking. If pressure differential is not observed or blower* rotation is not correct:

3-Disconnect all remote electrical power supplies.

4-Reverse any two field-installed wires connected to the line side of S48 disconnect or TB13 terminal strip. Do not reverse wires at blower contactor.

5-Make sure the connections are tight. Discharge and suction pressures should operate at their normal start-up ranges.

*Supply air inverter blower motors should rotate in the correct direction; verify scroll compressor rotation separately. Contact technical support if the blower is rotating incorrectly.

WARNING

1-Make sure that unit is installed in accordance with the installation instructions and applicable codes.

2-Inspect all electrical wiring, both field- and factory installed, for loose connections. Tighten as required.

3-Check to ensure that refrigerant lines do not rub against the cabinet or against other refrigerant lines.

4-Check voltage at disconnect switch. Voltage must be within range listed on nameplate. If not, consult power company and have voltage condition corrected before starting unit.

5-Make sure filters are new and in place before start-up.

B-Blower Access

- 1 - Disconnect jack/plug connector to blower motor. Also disconnect jack/plug connector heating limit switches on gas units.
- 2 - Remove screws on either side of blower assembly sliding base. See FIGURE 19.
- 3 - Pull base toward outside of unit.

C-Determining Unit CFM

IMPORTANT - Multi-staged supply air units are factory-set to run the blower at full speed when there is a blower (G) demand without a heating or cooling demand. Refer to the field-provided, design specified CFM for all modes of operation. Use the following procedure to adjust motor pulley to deliver the highest CFM called for in the design spec. See Inverter Start-Up section to set blower CFM for all modes once the motor pulley is set.

- 1 - The following measurements must be made with a dry indoor coil. Run blower (G demand) without a cooling demand. Measure the indoor blower shaft RPM. Air filters must be in place when measurements are taken.

- 2 - With all access panels in place, measure static pressure external to unit (from supply to return). Blower performance data is based on static pressure readings taken in locations shown in FIGURE 18.

Note - Static pressure readings can vary if not taken where shown.

- 3 - See table of contents for Blower Data and or Optional Accessories. Use static pressure and RPM readings to determine unit CFM.
- 4 - The blower RPM can be adjusted at the motor pulley. Loosen Allen screw and turn adjustable pulley clockwise to increase CFM. Turn counterclockwise to decrease CFM. See FIGURE 19. Do not exceed minimum and maximum number of pulley turns as shown in TABLE 5.

TABLE 5

MINIMUM AND MAXIMUM PULLEY ADJUSTMENT

Belt	Min Turns Open	Max Turns Open
A Section	No Minimum	5
B Section	1*	6

*No minimum number of turns open when B belt is used on pulleys 6" O.D. or larger.

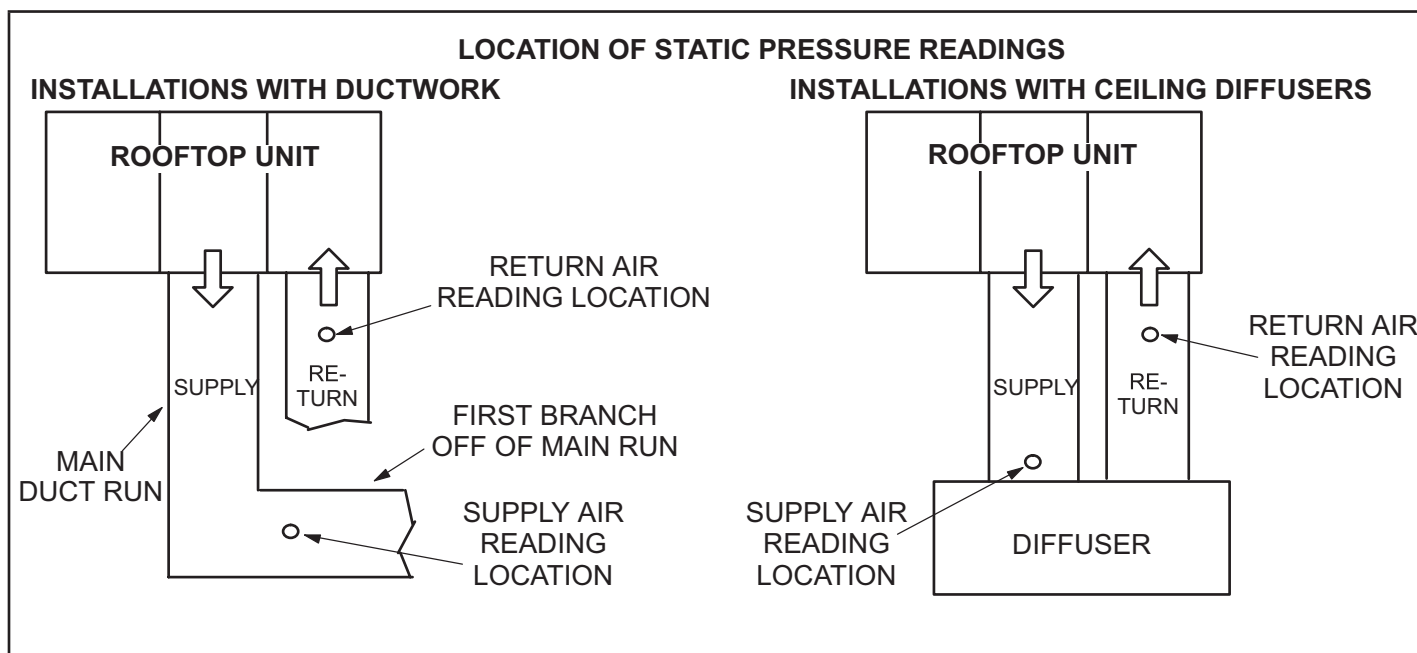

FIGURE 18

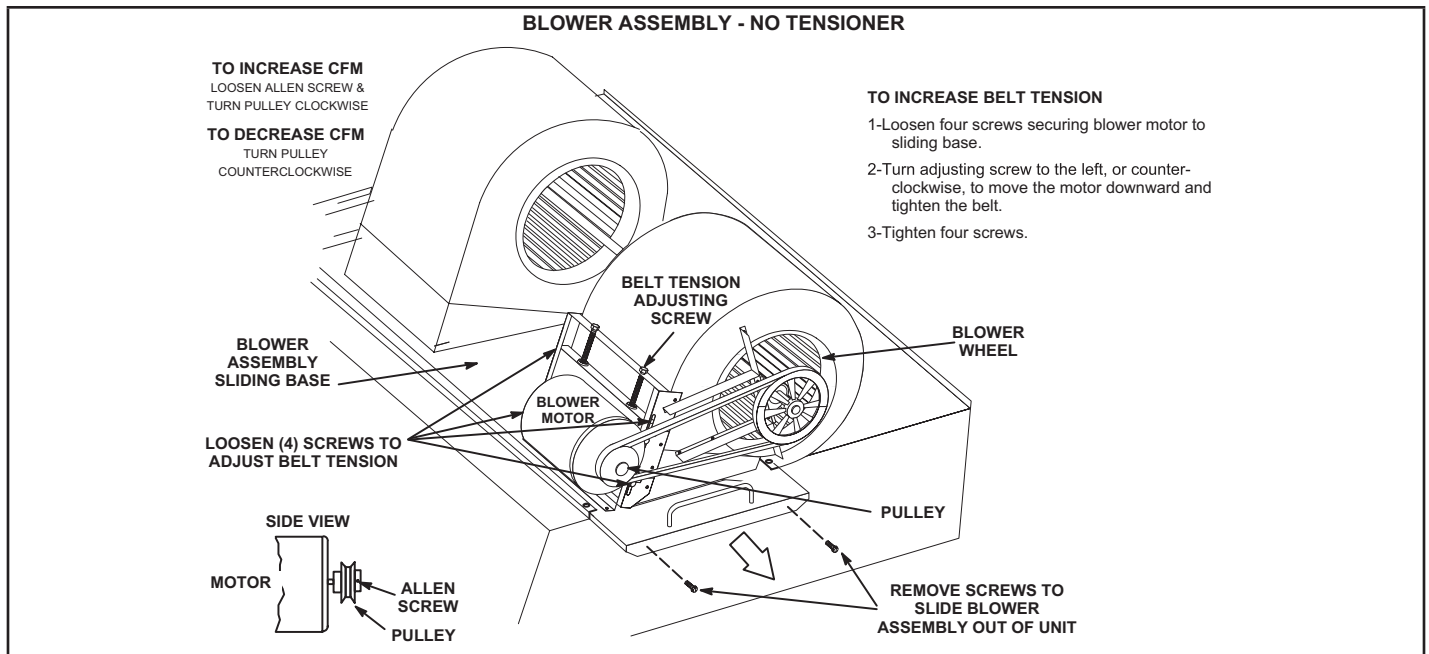

FIGURE 19

D-Blower Belt Adjustment

Maximum life and wear can be obtained from belts only if proper pulley alignment and belt tension are maintained. Tension new belts after a 24-48 hour period of operation. This will allow belt to stretch and seat into pulley grooves. Make sure blower and motor pulley are aligned. See FIGURE 20.

- 1 - Loosen four screws securing blower motor to sliding base. See FIGURE 19.
- 2 - To increase belt tension -
Turn belt tension adjusting screw to the left, or counterclockwise, to tighten the belt. This increases the distance between the blower motor and the blower housing.
To loosen belt tension -
Turn the adjusting screw to the right, or clockwise to loosen belt tension.
- 3 - Tighten four screws securing blower motor to sliding base once adjustments have been made.

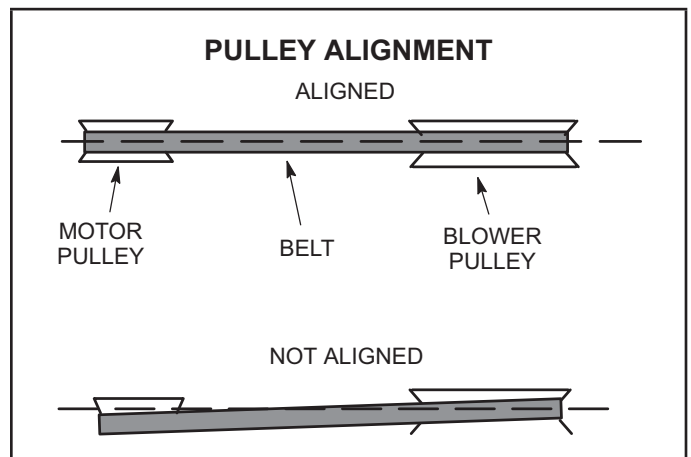

FIGURE 20

E-Check Belt Tension

Overtensioning belts shortens belt and bearing life. Check belt tension as follows:

- 1 - Measure span length X. See FIGURE 21.
- 2 - Apply perpendicular force to center of span (X) with enough pressure to deflect belt $1/64$ " for every inch of span length or 1.5mm per 100mm of span length.
Example: Deflection distance of a 40" span would be $40/64$ " or $5/8$ ".
Example: Deflection distance of a 400mm span would be 6mm.
- 3 - Measure belt deflection force. For a used belt, the deflection force should be 5 lbs. (35kPa) . A new belt deflection force should be 7 lbs. (48kPa).

A force below these values indicates an undertensioned belt. A force above these values indicates an overtensioned belt.

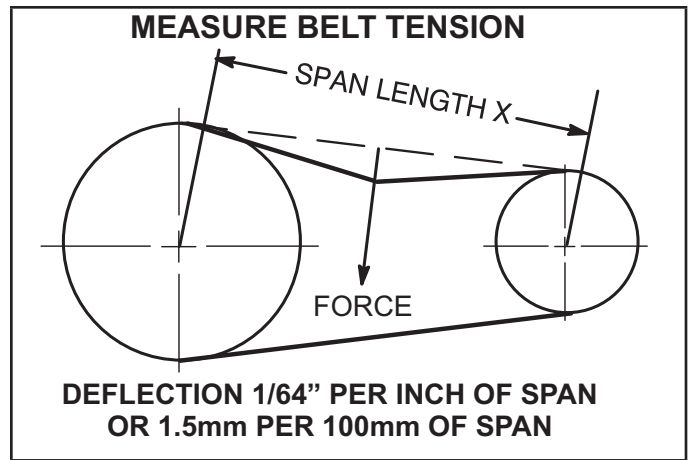

FIGURE 21

F-Field-Furnished Blower Drives

See BLOWER DATA tables for blower drives.

D-OPTIONAL ELECTRIC HEAT

See ELECTRICAL / ELECTRIC HEAT DATA and ELECTRIC HEAT CAPACITIES (table of contents) for LHX to EHA match-ups and electrical ratings.

EHA parts arrangement is shown in FIGURE 23 and FIGURE 24. All electric heat sections consist of electric heating elements exposed directly to the air stream. Two electric heat sections (first section and second section) are used in all 15kW through 90kW heaters. See FIGURE 22. Multiple-stage elements are sequenced on and off in response to thermostat demand.

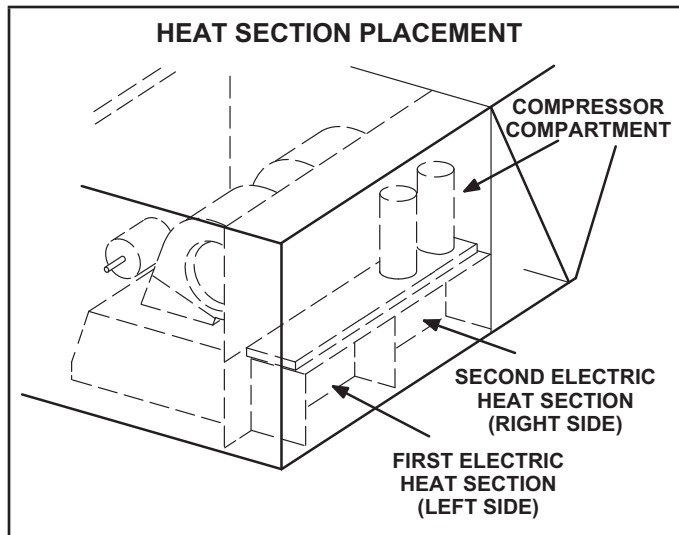

FIGURE 22

1-Main Control Box Components A55, K9

The main control box (FIGURE 3) houses the A55 Unit Controller and the K9 electric heat relay.

2-Contactors K15, K16, K17 and K18

Contactors K15, K16, K17 and K18 are all three-pole double-break contactors located on the electric heat vestibule. K15 and K16 are located on the first electric heat section, while K17 and K18 are located on the second electric heat section. However, in the 15 and 30kW heaters, the first section houses all contactors and fuses. All contactors are equipped with a 24VAC coil. The coils in the K15, K16, K17 and K18 contactors are energized by the main panel A55. Contactors K15 and K17 energize the first stage heating elements, while K16 and K18 energize the second stage heating elements.

3-High Temperature Limits S15 and S107 (Primary)

S15 and S107 are SPST N.C. auto-reset thermostats located on the back panel of the electric heat section below the heating elements. S15 is the high temperature limit for the first electric heat section, while S107 is the high temperature limit for the second electric heat section. Both thermostats are identical and are wired to the A55 Unit Controller. When either S15 or S107 opens, indicating a problem in the system, contactor K15 is de-energized. When K15 is de-energized, first stage and all subsequent stages of heat are de-energized. The thermostats used on EHA360-45-1 Y/G/J are factory set to open at $200F \pm 5F$ on a temperature rise and automatically reset at $160F \pm 6F$ on a temperature fall. All other electric heat section thermostats are factory set to open at $170F \pm 5F$ on a temperature rise and automatically reset at $130F \pm 6F$ on a temperature fall. The thermostats are not adjustable.

4-Terminal Strip TB3

Electric heat line voltage connections are made to terminal strip TB3 (or a fuse block on some models) located in the upper left corner of the electric heat vestibule.

5-Heating Elements HE1 through HE14

Heating elements are composed of helix wound bare nichrome wire exposed directly to the air stream. Three elements are connected in a three-phase arrangement. The elements in 208/230V units are connected in a "Delta" arrangement. Elements in 460 and 575V units are connected in "Wye" arrangement.

Each stage is energized independently by the corresponding contactors located on the electric heat vestibule panel. Once energized, heat transfer is instantaneous. High temperature protection is provided by primary and redundant high temperature limits and overcurrent protection is provided by fuses.

6-Fuse F3

Fuse F3 are housed in a fuse block which holds three fuses. Each F3 fuse is connected in series with each leg of electric heat. FIGURE 23, FIGURE 24 and TABLE 6 show the fuses used with each electric heat section. For simplicity, the service manual labels the fuses F3 - 1 through F3 - 8

TYPICAL ELECTRIC HEAT SECTION COMPONENT LAYOUT

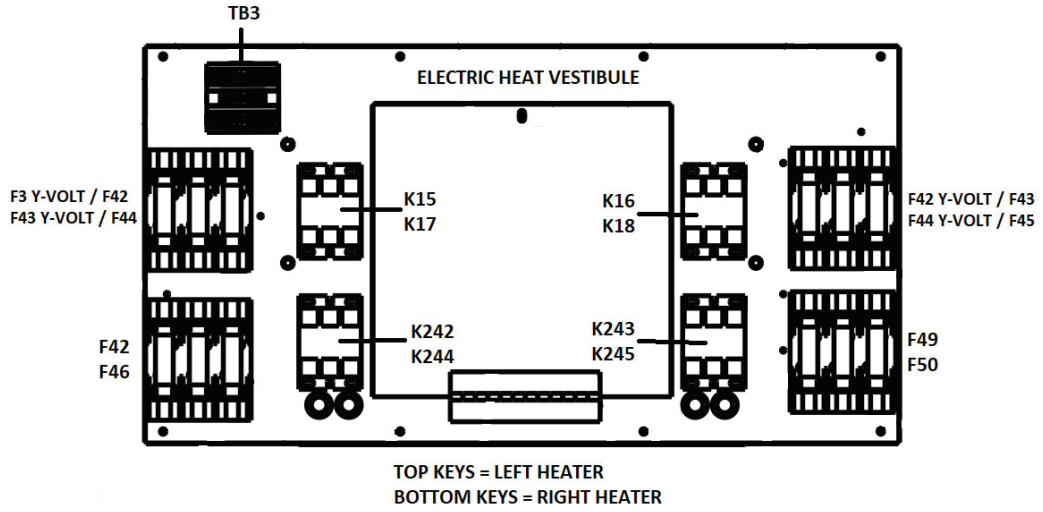

FIGURE 23

EHA 15, 30, 45, 60 and 90 KW
ELECTRIC HEAT SECTION PARTS
ARRANGEMENT

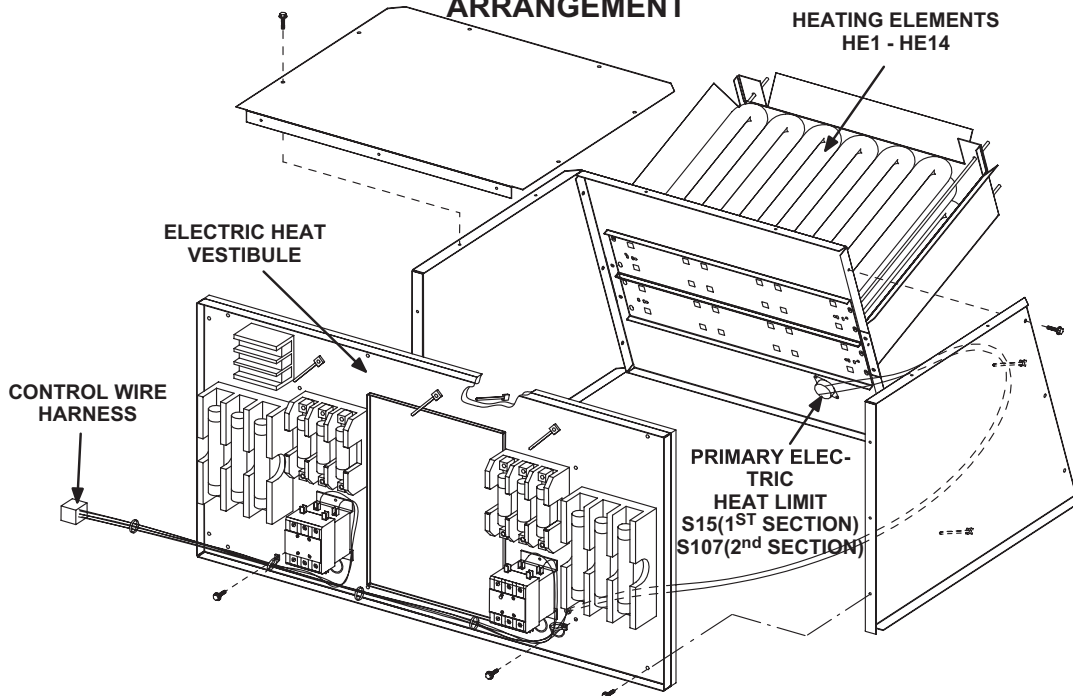

FIGURE 24

TABLE 6

ELECTRIC HEAT SECTION FUSE RATING									
EHA QUANTITY & SIZE	VOLTAGES	FUSE (3 each)							
		F3 - 1	F3 - 2	F3 - 3	F3 - 4	F3 - 5	F3 - 6	F3 - 7	F3 - 8
(1) EHA240-7.5 & (1) EHA240S-7.5 (15 kW Total)	208/230V	50 Amp 250V	----	----	----	----	----	----	----
	460V	25 Amp 600V	----	----	----	----	----	----	----
	575V	20 Amp 600V	----	----	----	----	----	----	----
(1) EHA360-15 & (1) EHA360S-15 (30 kW Total) or (1) EHA156-15 & (1) EHA156S-15	208/230V	60 Amp 250V	60 Amp 250V	----	----	----	----	----	----
	460V	50 Amp 600V	----	----	----	----	----	----	----
	575V	40 Amp 600V	----	----	----	----	----	----	----
(2) EHA360-22.5 (45 kW Total) or (2) EHA156-22.5	208/230V	50 Amp 250V	----	----	25 Amp 250V	50 Amp 250V	----	----	25 Amp 250V
	460V	25 Amp 600V	----	----	15 Amp 600V	25 Amp 600V	----	----	15 Amp 600V
	575V	20 Amp 600V	----	----	10 Amp 600V	20 Amp 600V	----	----	10 Amp 600V
(2) EHA150-30 (60 kW Total) or (2) EHA156-30	208/230V	50 Amp 250V	----	----	50 Amp 250V	50 Amp 250V	----	----	50 Amp 250V
	460V	25 Amp 600V	----	----	25 Amp 600V	25 Amp 600V	----	----	25 Amp 600V
	575V	20 Amp 600V	----	----	20 Amp 600V	20 Amp 600V	----	----	20 Amp 600V
(2) EHA360-45 (90 kW Total)	208/230V	50 Amp 250V	----	60 Amp 250V	60 Amp 250V	50 Amp 250V	----	60 Amp 250V	60 Amp 250V
	460V	25 Amp 600V	----	----	50 Amp 600V	25 Amp 600V	----	----	50 Amp 600V
	575V	20 Amp 600V	----	----	40 Amp 600V	20 Amp 600V	----	----	40 Amp 600V

II-PLACEMENT AND INSTALLATION

Make sure the unit is installed in accordance with the installation instructions and all applicable codes. See accessories section for conditions requiring use of the optional roof mounting frame.

III-CHARGING

⚠ WARNING

Refrigerant can be harmful if it is inhaled. Refrigerant must be used and recovered responsibly. Failure to follow this warning may result in personal injury or death.

WARNING - Do not exceed nameplate charge under any condition.

Refrigerant Charge R-454B		
Unit	M _c (lbs)	M _c (kg)
LHX180 circuit 1	22.50	10.21
LHX180 circuit 2	20.20	9.16
LHX240 circuit 1	22.00	9.98
LHX240 circuit 2	21.50	9.75
LHX300 circuit 1	22.20	10.07
LHX300 circuit 2	21.00	9.53

This unit is factory charged and should require no further adjustment. If the system requires additional refrigerant, reclaim the charge, evacuate the system and add required nameplate charge.

NOTE - System charging is not recommended below 60°F (15°C). In temperatures below 60°F (15°C), the charge must be weighed into the system.

If weighing facilities are not available, or to check the charge, use the following procedure:

IMPORTANT - Charge unit in normal cooling mode

- 1 - Attach gauge manifolds to discharge and suction lines. With the economizer disabled, operate the unit in **cooling mode at high speed** using the following mobile service app menu path:

SERVICE>TEST>COOL>COOL 2

- 2 - Use a thermometer to accurately measure the outdoor ambient temperature.
- 3 - Apply the outdoor temperature to TABLE 7 through TABLE 8 to determine normal operating pressures. Pressures are listed for sea level applications at 80°F dry bulb and 67°F wet bulb return air.
- 4 - Compare the normal operating pressures to the pressures obtained from the gauges. Minor variations in these pressures may be expected due to differences in installations. Significant differences could mean that the system is not properly charged or that a problem exists with some component in the system. **Correct any system problems before proceeding**

- 5 - If discharge pressure is high, remove refrigerant from the system. If discharge pressure is low, add refrigerant to the system.
 - Add or remove charge in increments.
 - Allow the system to stabilize each time refrigerant is added or removed.

In addition to conventional charging procedures, the following requirements shall be followed.

- Ensure that contamination of different refrigerants does not occur when using charging equipment. Hoses or lines shall be as short as possible to minimize the amount of refrigerant contained in them.
- Cylinders shall be kept in an appropriate position according to the instructions.
- Ensure that the unit is earth grounded prior to charging the system with refrigerant.
- Label the system when charging is complete (if not already).
- Extreme care shall be taken not to overfill the unit.

Prior to recharging the system, it shall be pressure-tested with the appropriate purging gas. The system shall be leak-tested on completion of charging but prior to commissioning. A follow up leak test shall be carried out prior to leaving the site.

- When removing refrigerant from a system, either for servicing or decommissioning, it is recommended good practice that all refrigerants are removed safely.
- When transferring refrigerant into cylinders, ensure that only appropriate refrigerant recovery cylinders are employed. Ensure that the correct number of cylinders for holding the total system charge is available. All cylinders to be used are designated for the recovered refrigerant and labelled for that refrigerant (i. e. special cylinders for the recovery of refrigerant). Cylinders shall be complete with pressure-relief valve and associated shut-off valves in good working order. Empty recovery cylinders are evacuated and, if possible, cooled before recovery
- The recovery equipment shall be in good working order with a set of instructions concerning the equipment that is at hand and shall be suitable for the recovery of all appropriate refrigerants including, when applicable, flammable refrigerants. In addition, a set of calibrated weighing scales shall be available and in good working order. Hoses shall be complete with leak-free disconnect couplings and in good condition. Before using the recovery machine, check that it is in satisfactory working order, has been properly maintained and that any associated electrical components are sealed to prevent ignition in the event of a refrigerant release. Consult manufacturer if in doubt.

- The recovered refrigerant shall be returned to the refrigerant supplier in the correct recovery cylinder, and the relevant waste transfer note arranged. Do not mix refrigerants in recovery units and especially not in cylinders.
- If compressors or compressor oils are to be removed, ensure that they have been evacuated to an acceptable level to make certain that flammable refrigerant does not remain within the lubricant. The evacuation process shall be carried out prior to returning the compressor to the suppliers. Only electric heating to the compressor body shall be employed to accelerate this process. When oil is drained from a system, it shall be carried out safely.

NOTE - System charging is not recommended below 60°F (15°C). In temperatures below 60°F (15°C), the charge must be weighed into the system.

If weighing facilities are not available, or to check the charge, use the following procedure:

- 1 - Make sure outdoor coil is clean. Attach gauge manifolds and operate unit at full CFM in cooling mode with economizer disabled until system stabilizes (approximately five minutes). Make sure all outdoor air dampers are closed.
- 2 - Compare the normal operating pressures to the pressures obtained from the gauges. Check unit components if there are significant differences.
- 3 - Measure the outdoor ambient temperature and the suction pressure. Refer to the charging curve to determine a target liquid temperature.

NOTE - Pressures are listed for sea level applications.

- 4 - Use the same thermometer to accurately measure the liquid temperature (in the outdoor section)
 - If measured liquid temperature is higher than the target liquid temperature, add refrigerant to the system.
 - If measured liquid temperature is lower than the target liquid temperature, recover some refrigerant from the system..
- 5 - Add or remove charge in increments. Allow the system to stabilize each time refrigerant is added or removed.
- 6 - Continue the process until measured liquid temperature agrees with the target liquid temperature. Do not go below the target liquid temperature when adjusting charge. Note that suction pressure can change as charge is adjusted.

TABLE 7**LHX180 NORMAL OPERATING PRESSURES - 581148-02**

Outdoor Coil Entering Air Temp°F	Circuit 1		Circuit 2	
	Dis. ±10 psig	Suc. ±5 psig	Dis. ±10 psig	Suc. ±5 psig
65	230	125	243	125
75	267	128	280	128
85	306	129	321	130
95	351	131	366	132
105	402	133	417	135
115	453	135	471	136

TABLE 8**LHX240 NORMAL OPERATING PRESSURES - 581149-02**

Outdoor Coil Entering Air Temp°F	Circuit 1		Circuit 2	
	Dis. +10 psig	Suc. +5 psig	Dis. +10 psig	Suc. +5 psig
65	251	121	262	120
75	290	124	303	125
85	333	126	349	127
95	382	129	399	129
105	433	131	453	131
115	489	133	511	134

TABLE 9**LHX300 NORMAL OPERATING PRESSURES - 581410-01**

Outdoor Coil Entering Temp.	CIRCUIT 1		CIRCUIT 2	
	Discharge ± 10 psig	Suction ± 5 psig	Discharge ± 10 psig	Suction ± 5 psig
65 °F	253	123	266	123
75 °F	291	124	306	126
85 °F	332	126	349	128
95 °F	377	127	396	130
105 °F	428	130	447	132
115 °F	482	133	503	134

B-Charge Verification - Approach Method - AHRI**Testing (Fin/Tube Coil)**

1 - 1- Using the same thermometer, compare liquid temperature to outdoor ambient temperature.

Approach Temperature = Liquid temperature (at outdoor coil outlet) minus ambient temperature.

2 - Approach temperature should match values in TABLE 10. An approach temperature greater than value shown indicates an undercharge. An approach temperature less than value shown indicates an overcharge.

3 - The approach method is not valid for grossly over or undercharged systems. Use TABLE 7 through TABLE 9 as a guide for typical operating pressures.

TABLE 10**APPROACH TEMPERATURES - FIN/TUBE COIL**

Unit	Liquid Temp. Minus Ambient Temp.	
	1st Stage	2nd Stage
180	7°F +/- 1° (3.9°C +/- 0.5)	9°F +/- 1° (5.0°C +/- 0.5)
240	8°F +/- 1° (4.4°C +/- 0.5)	10°F +/- 1° (5.5°C +/- 0.5)
300	9.5°F +/- 1° (5.3°C +/- 0.5)	10.5°F +/- 1° (5.8°C +/- 0.5)

IV- START-UP OPERATION

A-Preliminary and Seasonal Checks

- 1 - Make sure the unit is installed in accordance with the installation instructions and applicable codes.
- 2 - Inspect all electrical wiring, both field and factory installed for loose connections. Tighten as required. Refer to unit diagram located on inside of unit control box cover.
- 3 - Check to ensure that refrigerant lines are in good condition and do not rub against the cabinet or other refrigerant lines.
- 4 - Check voltage. Voltage must be within the range listed on the nameplate. If not, consult power company and have the voltage corrected before starting the unit.
- 5 - Recheck voltage and amp draw with unit running. If voltage is not within range listed on unit nameplate, stop unit and consult power company. Refer to unit nameplate for maximum rated load amps.
- 6 - Inspect and adjust blower belt (see section on Blower Compartment - Blower Belt Adjustment).

B-Cooling Start-up

NOTE-Crankcase heaters must be energized 24 hours before attempting to start compressor. Set thermostat so that there is no demand to prevent compressor from cycling. Apply power to unit.

- 1 - Initiate first and second stage cooling demands according to instructions provided with thermostat.
- 2 - First-stage thermostat demand will energize indoor blower in Low Cooling CFM. Second-stage thermostat demand will energize indoor blower in High Cooling CFM. Both demands energize compressor 1. The remaining compressors will be energized as needed to meet cooling demand.
- 3 - 180, 240, and 300 units contain two refrigerant circuits or systems.
- 4 - Each refrigerant circuit is separately charged with R454B refrigerant. See unit rating plate for correct amount of charge.
- 5 - Refer to the Refrigerant Check and Charge section to check refrigerant charge.

C-Heating Startup

- 1 - Set thermostat or temperature control device to initiate a first-stage heating demand.
- 2 - A first-stage heating demand (W1) will energize compressor heat pump heating, the outdoor fans, and the blower..
- 3 - A second-stage heating demand (W2) will energize the electrical heaters if available.

V- SYSTEMS SERVICE CHECKS

A-Cooling System Service Checks

LHX units are factory charged and require no further adjustment; however, charge should be checked periodically using the liquid temperature plots in section IIICHARGING.

VI-MAINTENANCE

The unit should be inspected once a year by a qualified service technician.

⚠ WARNING	
	Electric shock hazard. Can cause injury or death. Before attempting to perform any service or maintenance, turn the electrical power to unit OFF at disconnect switch(es). Unit may have multiple power supplies.

⚠ CAUTION	
As with any mechanical equipment, contact with sharp sheet metal edges can result in personal injury. Take care while handling this equipment and wear gloves and protective clothing.	

⚠ WARNING	
Any service personnel installing, decommissioning, or performing maintenance on the unit must be properly trained with A2L refrigerants	

Prior to beginning work on systems containing refrigerant to ensure the risk of ignition is minimized:

- All work shall be undertaken under a controlled procedure so as to minimize the risk of a flammable gas or vapor being present while the work is being performed.
- The area shall be checked with an appropriate refrigerant detector prior to and during work, to ensure the technician is aware of potentially toxic or flammable atmospheres. Ensure that the leak detection equipment being used is suitable for use with all applicable refrigerants, i. e. non-sparking, adequately sealed or intrinsically safe.
- If any hot work is to be conducted on the refrigerating equipment or any associated parts, the appropriate fire extinguishing equipment shall be available to hand. Have a dry powder or CO2 fire extinguisher adjacent to the charging area.
- No person carrying out work in relation to a refrigerating system which involves exposing any pipe work shall use any sources of ignition in such a manner that it may lead to the risk of fire or explosion. All possible ignition sources, including ciga-

rette smoking, should be kept sufficiently far away from the site of installation, repairing, removing and disposal, during which refrigerant can possibly be released to the surrounding space. Prior to work taking place, the area around the equipment is to be surveyed to make sure that there are no flammable hazards or ignition risks. "No Smoking" signs shall be displayed.

- Ensure that the area is in the open or that it is adequately ventilated before breaking into the system or conducting any hot work.

A degree of ventilation shall continue during the period that the work is carried out. The ventilation should safely disperse any released refrigerant and preferably expel it externally into the atmosphere.

- Where electrical components are being changed, service technicians shall be fit for the purpose and to the correct specification. At all times the manufacturer's maintenance and service guidelines shall be followed. If in doubt, consult the manufacturer's technical department for assistance. The following checks shall be applied to installations using flammable refrigerants as applicable:

- 1 - The actual refrigerant charge is in accordance with the room size within which the refrigerant containing parts are installed.
 - 2 - The ventilation machinery and outlets are operating adequately and are not obstructed.
 - 3 - If an indirect refrigerating circuit is being used, the secondary circuit shall be checked for the presence of refrigerant.
 - 4 - Markings on the equipment should be visible and legible. Markings and signs that are illegible shall be corrected.
 - 5 - Refrigerating pipes or components are installed in a position where they are unlikely to be exposed to any substance which may corrode refrigerant containing components, unless the components are constructed of materials which are inherently resistant to being corroded or are suitably protected against being so corroded.
- For systems containing refrigerant all repair and maintenance to electrical components shall include initial safety checks and component inspection procedures such as that capacitors are discharged in a safe manner to avoid possibility of sparking, that no live electrical components and wiring are exposed while charging, recovering, or purging the system, and that there is continuity of earth bonding. If a fault exists that could compromise safety, then no electrical supply shall be connected to the circuit until it is satisfactorily dealt with. If the fault cannot be corrected immediately but it is necessary to continue operation, an adequate temporary solution shall be used that is reported to the owner of the equipment, so all parties are advised.

NOTE - Sealed electrical components shall be replaced, not repaired.

NOTE - Inherently safe components must be replaced, not repaired.

- Under no circumstances shall potential sources of ignition be used in the searching for or detection of refrigerant leaks. A halide torch (or any other detector using a naked flame) shall not be used. Electronic leak detectors may be used to detect refrigerant leaks but, in the case of flammable refrigerants, the sensitivity may not be adequate, or may need re-calibration. (Detection equipment shall be calibrated in a refrigerant-free area.) Ensure that the detector is not a potential source of ignition and is suitable for the refrigerant used. Leak detection equipment shall be set at a percentage of the LFL of the refrigerant and shall be calibrated to the refrigerant employed, and the appropriate percentage of gas (25 % maximum) is confirmed. Leak detection fluids are also suitable for use with most refrigerants but the use of detergents containing chlorine shall be avoided as the chlorine may react with the refrigerant and corrode the copper pipe-work. If a leak is suspected, all naked flames shall be removed/extinguished. If a leakage of refrigerant is found which requires brazing, all of the refrigerant shall be recovered from the system, or isolated (by means of shut off valves) in a part of the system remote from the leak.
- When breaking into the refrigerant circuit to make repairs – or for any other purpose – conventional procedures shall be used. However, for flammable refrigerants it is important that best practice be followed, since flammability is a consideration. The following procedure shall be adhered to:
 - a. Safely remove refrigerant following local and national regulations,
 - b. Evacuate the circuit,
 - c. Purge the circuit with inert gas,
 - d. Evacuate,
 - e. Purge with inert gas,
 - f. Open the circuit.
- The refrigerant charge shall be recovered into the correct recovery cylinders if venting is not allowed by local and national codes. For appliances containing flammable refrigerants, the system shall be purged with oxygen-free nitrogen to render the appliance safe for flammable refrigerants. This process might need to be repeated several times. Compressed air or oxygen shall not be used for purging refrigerant systems. Refrigerant purging shall be achieved by breaking the vacuum in the system with oxygen-free nitrogen and continuing to fill until the working pressure is achieved, then venting to atmosphere, and finally pulling down to a vacuum. This process shall be repeated until no refrigerant is within the system. When the final oxygen-free nitrogen charge is used, the system shall be vented down to atmospheric pressure to enable work to take place. Ensure that the outlet for the vacuum pump is not close to any potential ignition sources and that ventilation is available.

Critical Components for Refrigerant Leak Containment

All Units

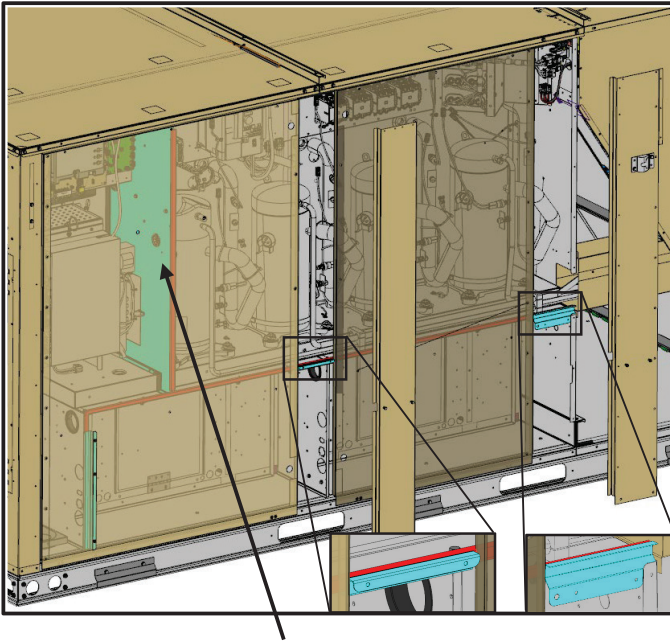

If the door panels, barrier, mullions and rubber seals (highlighted in red) must be removed for service, ensure they are returned to their proper places before starting the unit. Verify that the rubber seals on the barrier and the compressor base panel are properly aligned and tightly secured. Verify that the brackets behind the mullions are secured.

Hinged Door Panels

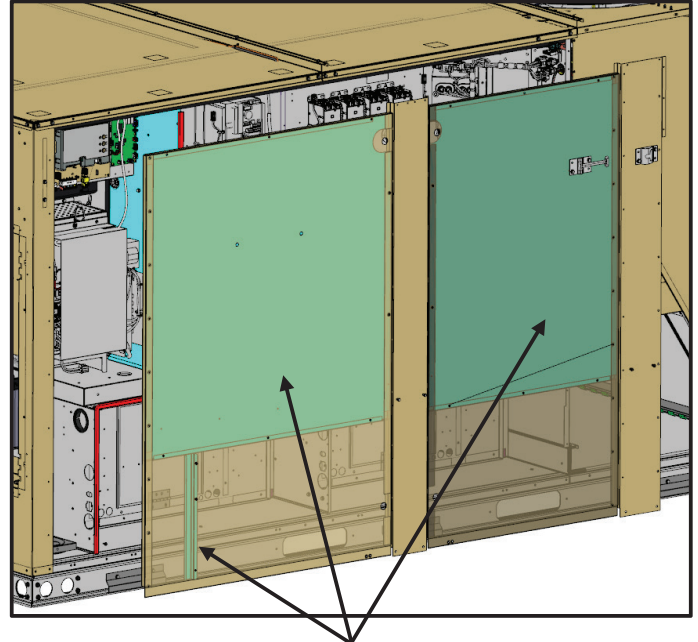

Verify that the door panel liners and bracket are tightly secured. These steps are critical to containing flammable refrigerant and preventing it from migrating to sources of ignition in the event of a leak.

Non-hinged Door Panels

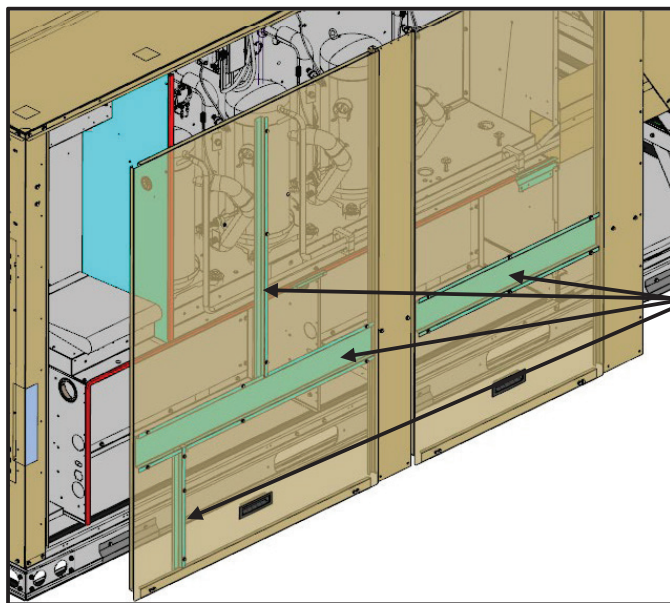

Verify that the door panel brackets are tightly secured. This is critical to containing flammable refrigerant and preventing it from migrating to sources of ignition in the event of a leak.

A-Filters

LHX units use six 24 X 24 X 2" fiberglass throw-away type filters. Filters may be accessed through the economizer / filter access door. Filters should be checked monthly (or more frequently in severe use) and cleaned or replaced regularly. Take note of the "AIR FLOW DIRECTION" marking on the filter frame when re-installing.

B-Lubrication

All motors and blower wheels used in LHX units are lubricated; no further lubrication is required.

C-Supply Air Blower Wheel

Annually inspect supply air blower wheel for accumulated dirt or dust. Turn off power before attempting to remove access panel or to clean blower wheel.

D-Evaporator Coil

Inspect and clean coil at beginning of each season. Clean using mild detergent or commercial coil cleanser. Check condensate drain pan and line, if necessary. Flush coil and condensate drain with water taking care not to get insulation, filters and return air ducts wet. Check connecting lines and coil for evidence of oil and refrigerant leaks.

E-Condenser Coil

Clean condenser coil annually with detergent or commercial coil cleaner and inspect monthly during the cooling season. Check connecting lines and coil for evidence of oil and refrigerant leaks.

F-Electrical

- 1 - Check all wiring for loose connections.
- 2 - Check for correct voltage at unit (unit operating).
- 3 - Check amp-draw on both condenser fan motor and blower motor.

Fan Motor Rating Plate ____ Actual _____

Indoor Blower Motor Rating Plate ____ Actual _____

VII-OPTIONAL ACCESSORIES

The accessories section describes the application of most of the optional accessories which can be factory or field installed to the LHX units.

A-Roof Curbs

When installing the LHX units on a combustible surface for downflow discharge applications, the hybrid C1CUR-B70C-1 8-in height, C1CURB71C-1 14-in height, C1CUR-B72C-01 18-in height and C1CURB73C-1 24-in roof mounting frame is used. The assembled hybrid mounting frame is shown in FIGURE 25. Refer to the roof mounting frame installation instructions for details of proper assembly and mounting. The roof mounting frame **MUST** be squared to the roof and level before mounting. Plenum system **MUST** be installed before the unit is set on the mounting frame. Typical roof curbing and flashing is shown in FIGURE 26. Refer to the roof mounting frame installation instructions for proper plenum construction and attachment.

For horizontal discharge applications, use the standard C1URB14C-1 26-in or C1CURB16C-1 37-in height roof mounting frame. This frame converts unit from down-flow to horizontal air flow. The 37 inch horizontal frame meets National Roofing Code requirements. The roof mounting frames are recommended in all other applications but not required. If the LHX units are not mounted on a flat (roof) surface, they **MUST** be supported under all edges and under the middle of the unit to prevent sagging. The units **MUST** be mounted level within 1/16" per linear foot or 5mm per meter in any direction.

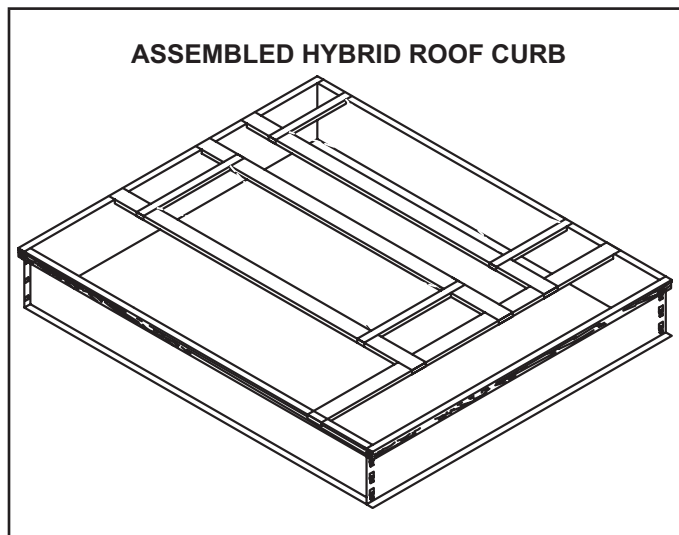

FIGURE 25

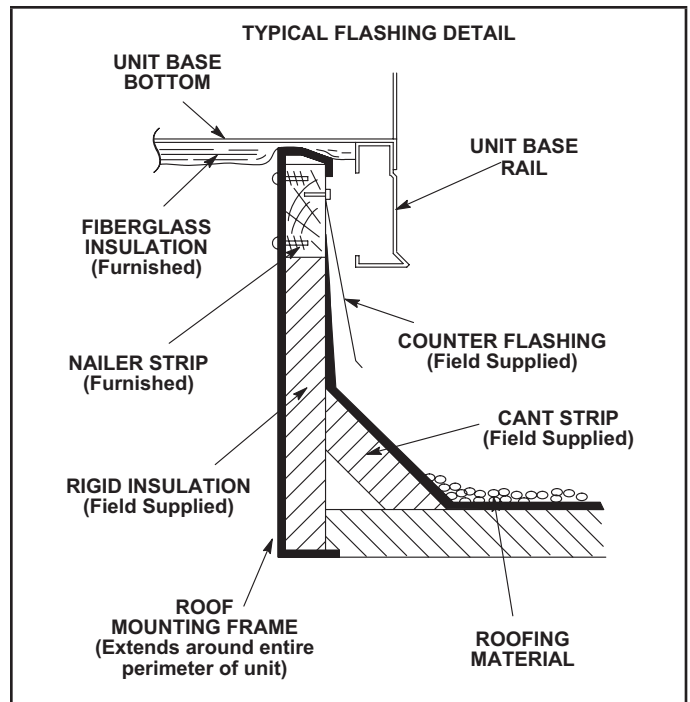

FIGURE 26

B-Transitions

Optional supply/return transitions C1DIFF33C-1 and C1DIFF34C-1 are available for use with LHX series units utilizing optional C1CURB roof curbs. Transition must be installed in the roof curb before mounting the unit to the frame. Refer to the manufacturer's instructions included with the transition for detailed installation procedures.

C-C1DAMP10 & E1DAMP20 Outdoor Air Dampers

C1DAMP10C and E1DAMP20C (FIGURE 27) consist of a set of dampers which may be manually or motor operated to allow up to 25 percent outside air into the system at all times. Either air damper can be installed in LHX units. Washable filter supplied with the outdoor air dampers can be cleaned with water and a mild detergent. It should be sprayed with Filter Handicoater when dry prior to re-installation. Filter Handicoater is R.P. Products coating no. 418 and is available as Part No. P-8-5069.

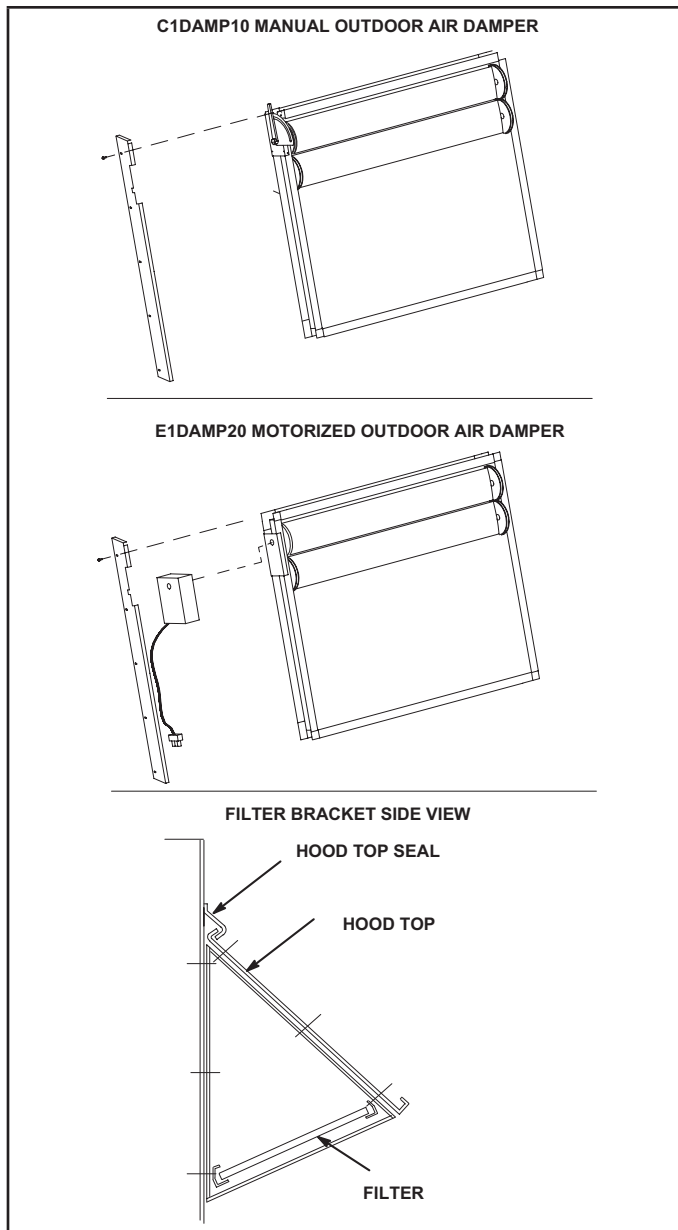

FIGURE 27

D-Supply and Return Diffusers

Optional flush mount diffuser/return FD11 and extended mount diffuser/return RTD11 are available for use with all LHX units. Refer to manufacturer's instructions included with transition for detailed installation procedures.

High Performance Economizer (Field or Factory Installed)

The optional economizer can be used with downflow and horizontal air discharge applications. The economizer uses outdoor air for free cooling when temperature and/or humidity is suitable. An economizer hood is furnished with the economizer.

NOTE - Gravity exhaust dampers are required with power exhaust.

The economizer is controlled by the A55 Unit Controller. The economizer will operate in one of four modes. Each mode requires a different A55 Unit Controller DIP switch setting. Each mode also requires different sensors. The following is a brief description. See economizer installation instruction for more detail.

1-"TMP" MODE (SENSIBLE TEMPERATURE)

In the "TMP" mode, the IMC uses input from the factory installed RT6 Supply Air Sensor, RT16 Return Air Sensor and RT17 Outdoor Air Sensor to determine suitability of outside air and economizer damper operation. When outdoor sensible temperature is less than return air sensible temperature, outdoor air is used for cooling. This may be supplemented by mechanical cooling to meet comfort demands. This application does not require additional optional sensors.

2-"ODE" MODE (OUTDOOR ENTHALPY)

The "ODE" or outdoor enthalpy mode requires a field-provided and -installed Honeywell C7400 enthalpy sensor (16K96). The sensor monitors outdoor air temperature and humidity (enthalpy). When outdoor air enthalpy is below the enthalpy control setpoint, the economizer modulates to allow outdoor air for free cooling.

3-"DIF" MODE (DIFFERENTIAL ENTHALPY)

The "DIF" or differential enthalpy mode requires two field-provided and -installed Honeywell C7400 enthalpy sensors (16K97). One sensor is installed in the outside air opening and the other sensor is installed in the return air opening. When the outdoor air enthalpy is below the return air enthalpy, the economizer opens to bring in outdoor air for free cooling.

4-"GLO" MODE (GLOBAL)

Global Mode - The "GLO" or global mode is used with an energy management system which includes a global control feature. Global control is used when multiple units (in one location) respond to a single outdoor air sensor. Each energy management system uses a specific type of outdoor sensor which is installed and wired by the controls contractor.

Motorized Outdoor Air Damper - The "GLO" mode is also used when a motorized outdoor air damper is installed in the system.

NOTE - All economizer modes of operation will modulate dampers to 55F supply air.

F-Gravity Exhaust Dampers

C1DAMP50C dampers (FIGURE 28) are used in downflow and LAGEDH are used in horizontal air discharge applications. LAGEDH gravity exhaust dampers are installed in the return air plenum. The dampers must be used any time an economizer or power exhaust fans are applied to LHX series units. An exhaust hood is furnished with the gravity exhaust damper.

Gravity exhaust dampers allow exhaust air to be discharged from the system when an economizer and/or power exhaust is operating. Gravity exhaust dampers also prevent outdoor air infiltration during unit off cycle. See installation instructions for more detail.

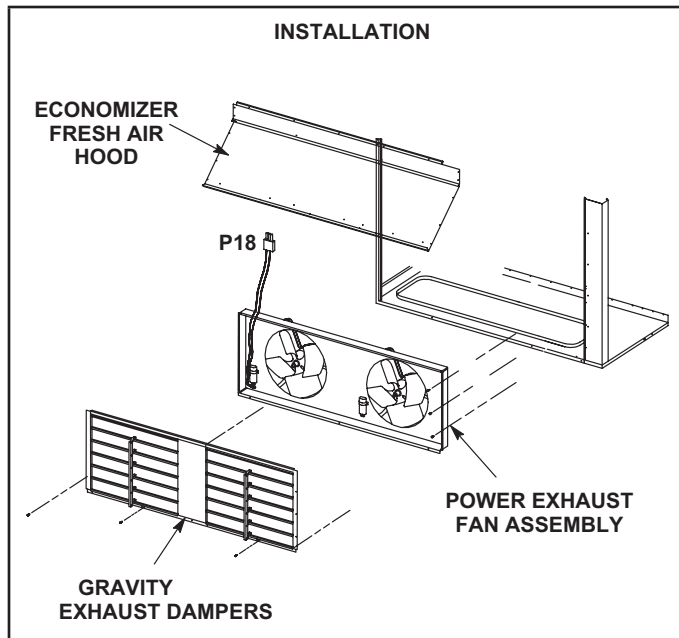

FIGURE 28

G-C1PWRE10 Power Exhaust Fans

C1PWRE10 power exhaust fans are used in downflow applications only. C1PWRE10 fans require optional downflow gravity exhaust dampers and E1ECON15 economizers. Power exhaust fans provide exhaust air pressure relief and also run when return air dampers are closed and supply air blowers are operating. FIGURE 28 shows the location of the power exhaust fans. See installation instructions for more detail.

H-Control Systems

The A55 Unit Controller provides all control function for the rooftop unit. Default operation requires a standard room thermostat or direct digital controller (DDC). The A55 can also control the unit from a zone temperature sensor. The A55 Unit Controller is a network controller when daisy-chained to the L Connection® Network Control System. For ease of configuration, the A55 can be connected to a PC with Unit Controller PC software installed.

I-Smoke Detectors A171, A172, A173

Photoelectric smoke detectors are a factory- and field-installed option. The smoke detectors can be installed in the supply air section (A172), return air section (A171), or in both the supply and return air section. Smoke detection control module (A173) is located below the control panel. Wiring for the smoke detectors are shown on the temperature control section (C) wiring diagram in back of this manual.

J-Blower Proving Switch S52

The blower proving switch monitors blower operation and locks out the unit in case of blower failure. The switch is N.O. and closes at .15" W.C. The switch is mounted on the middle left corner of the blower support panel. Wiring for the blower proving switch is shown on the temperature control section (C) wiring diagram in back of this manual.

K-Dirty Filter Switch S27

The dirty filter switch senses static pressure increase indicating a dirty filter condition. The switch is N.O. and closes at 1" W.C. The switch is mounted on the top corner of the economizer. Wiring for the dirty filter switch is shown on the temperature control section (C) wiring diagram in back of this manual.

L-Optional UVC Lights

The Healthy Climate germicidal light emits ultraviolet (UVC) energy that has been proven effective in reducing microbial life forms (viruses, bacteria, yeasts and molds) in the air.

UVC germicidal lamps greatly reduce the growth and proliferation of mold and other bio-aerosols (bacteria and viruses) on illuminated surfaces.

Germicidal lamps are NOT intended to be used for removal of active mold growth. Existing mold growth must be appropriately removed PRIOR to installation of the germicidal lamp.

Refer closely to UVC light installation instruction warnings when servicing units.

M-Drain Pan Overflow Switch S149 (optional)

The overflow switch is used to interrupt cooling operation when excessive condensate collects in the drain pan. The N.C. overflow switch is connected to the M4 Unit Controller (A55) through DI-3. When the switch opens, the Unit Controller will shut off the unit. After a five-minute time out, the Unit Controller will verify the overflow switch position and restart the unit (if the switch has closed). The Unit Controller has a three-strike counter before the unit locks out. This means the Unit Controller will allow the overflow switch to open three times per thermostat demand. If the unit locks out, a reset of the Unit Controller is required after the switch has closed to restore unit operation.

N-Bipolar Ionizer

The Needlepoint Bipolar Ionizer (NBPI) kit is specifically designed for LG/LC/LH/LD/KG/KC/KH 024-300 units. The ionizer is equipped with dry contacts which allow a Building Automation System (BAS) to interface and indicate ionizer functionality.

Note - The BAS will be able to monitor units equipped with M4 Unit Controllers only. The ionizers are also equipped with a green LED which indicates power is on. When the blower is in operation, power is delivered to the ionizers and ions are generated. See TABLE 11 for unit application.

TABLE 11

LHX Unit	Part No.	
180	21U37	622688-03
240	21U38	622688-04
300	21U39	622688-05

VIII--MULTI-STAGED BLOWER

A-Design Specifications

Use the TABLE 12 to fill in test and balance values when setting up the unit. If only high and low cooling design specifications are provided, set the medium cooling CFM at the high or low cooling design spec or any CFM between.

B-Set Maximum CFM

Use attached table to determine highest blower CFM for appropriate unit. Adjust the blower pulley to deliver that amount of CFM with only the blower operating. See Determining Unit CFM in the Blower Operation and Adjustment section.

C-Set Blower Speeds

- 1 - Use the following mobile service app menu to enter the blower design specified CFM into the Unit Controller. Make sure blower CFM is within limitations shown in TABLE 12 or TABLE 13. Refer to the Unit Controller manual provided with unit.

RTU MENU > RTU OPTIONS > BLOWER > SPEED

- 2 - Enter the following design specifications as shown in TABLE 12.

Blower /

Heat CFM

Cooling High CFM

Cooling Low CFM

Vent CFM

- 3 - Adjust the blower RPM to deliver the target CFM based on the measured static pressure using the blower table.
- 4 - Measure the static pressure again and apply the static pressure and RPM to the blower tables to determine adjusted CFM.
- 5 - Repeat adjustments until design CFM is reached.

D-Set Damper Minimum Position

To maintain required minimum ventilation air volumes when the unit is in the occupied mode, two minimum damper positions must be set.

The Unit Controller will open the damper to "Min OCP Blwr High" when blower CFM is at or ABOVE the "midpoint" CFM.

The Unit Controller will open the dampers to "Min OCP Blwr Low" when blower CFM is BELOW a "midpoint" CFM.

The Unit Controller will calculate the "midpoint" CFM.

*Available blower speeds vary by unit and thermostat stages.

Set Minimum Position 1

Use the following mobile service app menu to set "Min OCP Blwr High" for the blower CFM above the "midpoint" CFM. When navigating into this menu, the Unit Controller will run damper calibration and allow damper position adjustment.

RTU MENU > SETTINGS > RTU OPTIONS > DAMPER

Tap "Next" to skip tabs and complete damper position calibration until "Damper Calibration Blower Speed High" tab appears.

Measure the intake air CFM. If the CFM is lower than the design specified CFM for ventilation air, use the Unit Controller to increase the damper percent open. If the CFM is higher than specified, decrease the damper percent open.

Note - *Intake air CFM can also be determined using the outdoor air temperature, return air temperature and mixed air temperature. Refer to the economizer or outdoor air damper installation instructions.*

Set Minimum Position 2

Use the following mobile service app menu in the Unit Controller to set "Min OCP Blwr Low" for the blower CFM below the "midpoint" CFM. When navigating into this menu, the Unit Controller will run damper calibration and allow damper position adjustment.

RTU MENU > SETTINGS > RTU OPTIONS > DAMPER

Tap "Next" to skip tabs and complete damper position calibration until "Damper Calibration Blower Speed High" tab appears.

Measure the intake air CFM. If the CFM is lower than the design specified CFM for ventilation air, use the Unit Controller to increase the damper percent open. If the CFM is higher than specified, decrease the damper percent open.

Note - *Intake air CFM can also be determined using the outdoor air temperature, return air temperature and mixed air temperature. Refer to the economizer or outdoor air damper installation instructions.*

**TABLE 12
HEATING, VENTILATION & SMOKE MINIMUM AND MAXIMUM CFM**

Unit			Heating CFM			Vent CFM			Smoke CFM		
Model	Speed	Heat Code	Default	Min	Max	Default	Min	Max	Default	Min	Max
LHX180S	HP W/O EH	N	6000	4500	7200	6000	2250	7200	6000	2250	7200
	15, 30, 45, 60, 90 KW	E, J, K, L, P		6000							
LHX240S	HP W/O EH	N	7500	6000	9600	8000	3000	9600	8000	3000	9600
	15, 30, 45, 60, 90 KW	E, J, K, L, P									
LHX300S	HP W/O EH	N	9000	6000	12000	10000	3750	12000	10000	3750	12000
	15, 30, 45, 60, 90 KW	E, J, K, L, P									

*Use highest value between Heating and Cooling High CFM max

**TABLE 13
COOLING MINIMUM AND MAXIMUM CFM**

LHX Unit	Cooling Low CFM			Cooling High CFM		
	Default	Min	Max	Default	Min	Max
180S	3900	2000	7200	5400	5000	7200
240S	5200	3000	9600	7200	6250	9600
300S	6500	4000	12000	9000	7000	12000

*Use Cooling High CFM Max

IX-DECOMMISSIONING

Before carrying out this procedure, it is essential that the technician is completely familiar with the equipment and all its detail. It is recommended good practice that all refrigerants are recovered safely. Prior to the task being carried out, an oil and refrigerant sample shall be taken in case analysis is required prior to re-use of recovered refrigerant. It is essential that electrical power is available before the task is commenced.

Steps to ensure this are:

- Become familiar with the equipment and its operation,
- Isolate the system electrically,
- Ensure that before attempting the procedure that mechanical handling equipment is available, if required, for handling refrigerant cylinders, and that all personal protective equipment is available and being used correctly while the recovery process is supervised at all times by a competent person and that the recovery equipment and cylinders conform to the appropriate standards.

Additionally, pump down refrigerant system, if possible, and if a vacuum is not possible, make a manifold so that refrigerant can be removed from various parts of the system. Make sure that cylinders are situated on the scales before recovery takes place. Start the recovery machine and operate in accordance with instructions. Do not overfill cylinders (no more than 80 % volume liquid charge). Do not exceed the maximum working pressure of the cylinder, even temporarily. When the cylinders have been filled correctly and the process completed, make sure that the cylinders and the equipment are removed from site promptly and all isolation valves on the equipment are closed off. Recovered refrigerant shall not be charged into another refrigerating system unless it has been cleaned and checked.

Equipment shall be labeled stating that it has been decommissioned and emptied of refrigerant. The label shall be dated and signed. For appliances containing flammable refrigerants, ensure that there are labels on the equipment stating the equipment contains flammable refrigerant.

Under no circumstances shall potential sources of ignition be used in the searching for or detection of refrigerant leaks. A halide torch (or any other detector using a naked flame) shall not be used. Electronic leak detectors may be used to detect refrigerant leaks but, in the case of flammable refrigerants, the sensitivity may not be adequate,

or may need re-calibration. (Detection equipment shall be calibrated in a refrigerant-free area.) Ensure that the detector is not a potential source of ignition and is suitable for the refrigerant used. Leak detection equipment shall be set at a percentage of the LFL of the refrigerant and shall be calibrated to the refrigerant employed, and the appropriate percentage of gas (25 % maximum) is confirmed. Leak detection fluids are also suitable for use with most refrigerants but the use of detergents containing chlorine shall be avoided as the chlorine may react with the refrigerant and corrode the copper pipe-work. If a leak is suspected, all naked flames shall be removed/extinguished. If a leakage of refrigerant is found which requires brazing, all of the refrigerant shall be recovered from the system, or isolated (by means of shut off valves) in a part of the system remote from the leak.

When breaking into the refrigerant circuit to make repairs – or for any other purpose – conventional procedures shall be used. However, for flammable refrigerants it is important that best practice be followed, since flammability is a consideration. The following procedure shall be adhered to:

- Safely remove refrigerant following local and national regulations,
- Evacuate the circuit,
- Purge the circuit with inert gas,
- Evacuate,
- Purge with inert gas,
- Open the circuit.

The refrigerant charge shall be recovered into the correct recovery cylinders if venting is not allowed by local and national codes. For appliances containing flammable refrigerants, the system shall be purged with oxygen-free nitrogen to render the appliance safe for flammable refrigerants. This process might need to be repeated several times. Compressed air or oxygen shall not be used for purging refrigerant systems. Refrigerant purging shall be achieved by breaking the vacuum in the system with oxygen-free nitrogen and continuing to fill until the working pressure is achieved, then venting to atmosphere, and finally pulling down to a vacuum. This process shall be repeated until no refrigerant is within the system. When the final oxygen-free nitrogen charge is used, the system shall be vented down to atmospheric pressure to enable work to take place. Ensure that the outlet for the vacuum pump is not close to any potential ignition sources and that ventilation is available.

X-WIRING DIAGRAMS AND SEQUENCE OF OPERATION

THERMOSTAT

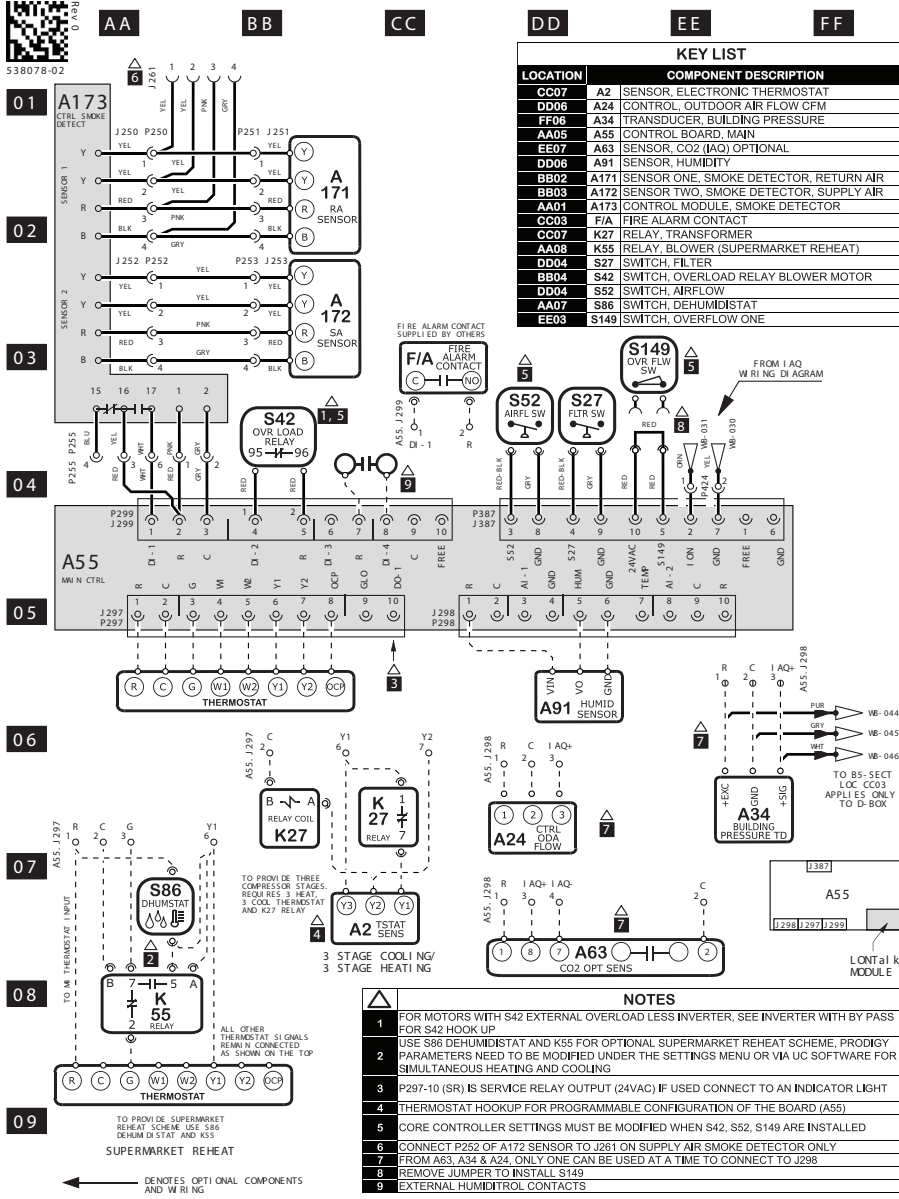

Model: LC, LG, LH, LD Series RTU Thermostat
 Voltage: All Voltages
 Supersedes: 538078-01 Form No: 538078- 02 Rev: 0

HEATING SECTION A COOLING SECTION B COOLING SECTION B3/S ACCS SECTION C ACCS SECTION D

WIRING DIAGRAM FLOW

REV	EC NO.	DATE	BY	APVD	REVISION NOTE
---	CN-012295C	04-03-2024	MXR6	MXT5	ORIGINATED AT PD&R CARROLLTON, TX



ECONOMIZER



AA

BB

CC

DD

01

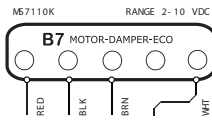

02

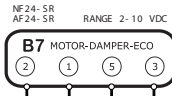

03



04

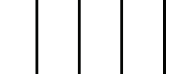

05

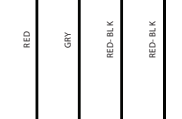

06

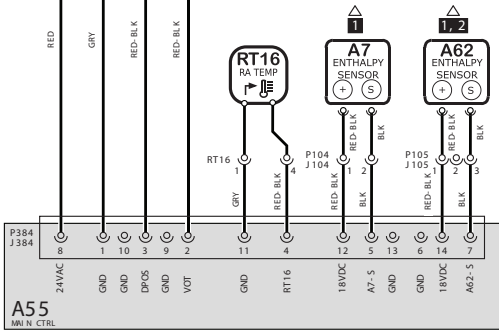

07

NOTES	
1	A7 AND A62 NOT USED FOR SENSIBLE TEMPERATURE CONTROL
2	FOR UNIT DIFFERENTIAL ENTHALPY CONTROL, ADD A62 RETURN AIR ENTHALPY SENSOR

08

KEY LIST	
LOCATION	COMPONENT DESCRIPTION
CC05	A7 SENSOR, SOLID STATE ENTHALPY
AA06	A55 CONTROL BOARD, MAIN
DD05	A62 SENSOR, ENTHALPY INDOOR
BB02	B7 MOTOR, DAMPER ECONOMIZER
CC05	RT16 SENSOR, RETURN AIR TEMP

09

10 Model: LC,LG,LH,LD,SC,SG Series
 Economizer & Motorized OAD
 Voltage: All Voltages
 Supersedes: N/A Form No: 538072-01 Rev: 2

HTG SEC A	CLG SEC B	CLG SEC BB	ACCS SEC C	ACCS SEC D
-----------------	-----------------	------------------	------------------	------------------

WIRING DIAGRAM FLOW



REV	EC NO.	DATE	BY	APVD	REVISION NOTE
---	CN-008594	10/15/2020	RV	MXR6	ORIGINATED AT PD&R CARROLLTON, TX
001	CN-010356B	03/24/2022	MXR6	JAL21	UPDATED APPLICABLE MODEL NUMBERS.
002	CN-012457P	03/06/2024	AXL	AAH	A) ADDED SC, SG TO MODELS

EHA - 15/90 G Voltage

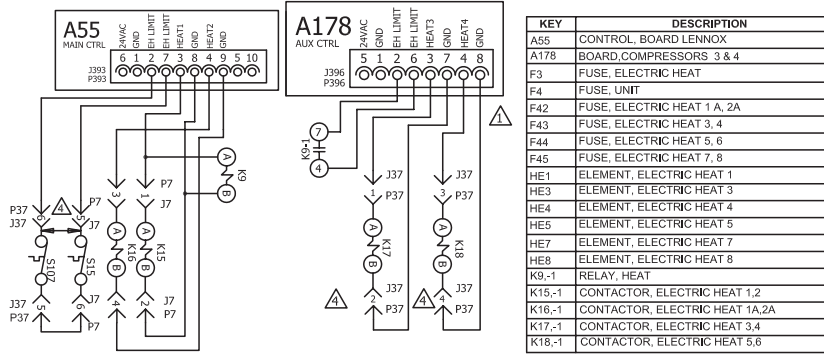

KEY	DESCRIPTION
A55	CONTROL BOARD LENNOX
A178	BOARD COMPRESSORS 3 & 4
F3	FUSE, ELECTRIC HEAT
F4	FUSE, UNIT
F42	FUSE, ELECTRIC HEAT 1 A, 2A
F43	FUSE, ELECTRIC HEAT 3, 4
F44	FUSE, ELECTRIC HEAT 5, 6
F45	FUSE, ELECTRIC HEAT 7, 8
HE1	ELEMENT, ELECTRIC HEAT 1
HE3	ELEMENT, ELECTRIC HEAT 3
HE4	ELEMENT, ELECTRIC HEAT 4
HE5	ELEMENT, ELECTRIC HEAT 5
HE7	ELEMENT, ELECTRIC HEAT 7
HE8	ELEMENT, ELECTRIC HEAT 8
K9-1	RELAY, HEAT
K15-1	CONTACTOR, ELECTRIC HEAT 1,2
K16-1	CONTACTOR, ELECTRIC HEAT 1A,2A
K17-1	CONTACTOR, ELECTRIC HEAT 3,4
K18-1	CONTACTOR, ELECTRIC HEAT 5,6

S15	SWITCH, LIMIT PRIMARY ELECTRIC HEAT
S20	SWITCH, LIMIT SECONDARY ELECTRIC HEAT 1,2
S107	SWITCH, PRIMARY ELECTRIC HEAT
S157	SWITCH, LIMIT SECONDARY ELECTRIC HEAT 1A
S158	SWITCH, LIMIT SECONDARY ELECTRIC HEAT 2A
S159	SWITCH, LIMIT SECONDARY ELECTRIC HEAT 3,4
S160	SWITCH, LIMIT SECONDARY ELECTRIC HEAT 5,6
TB2	TERMINAL STRIP, UNIT
TB3	TERMINAL STRIP, ELECTRIC HEAT

J/P	DESCRIPTION
7	ELECTRIC HEAT CONTROL
37	ELECTRIC HEAT CONTROL

DESIGNATION	VOLTAGE
G	460/60/3
J	575/3

- ⚠ NOT USED ON 15 AND 30KW UNITS
- ⚠ TB3 IS USED IN SOME UNITS
- ⚠ TB2, S48 OR CB10 MAY BE USED
- ⚠ REMOVE JUMPER PLUG WHEN FIELD INSTALLING ELECTRIC HEAT
- ⚠ F61 USED ON UNITS WITH SCRR OPTION
- ⚠ TB2 IS USED IN SOME SCRR OPTION UNITS ONLY

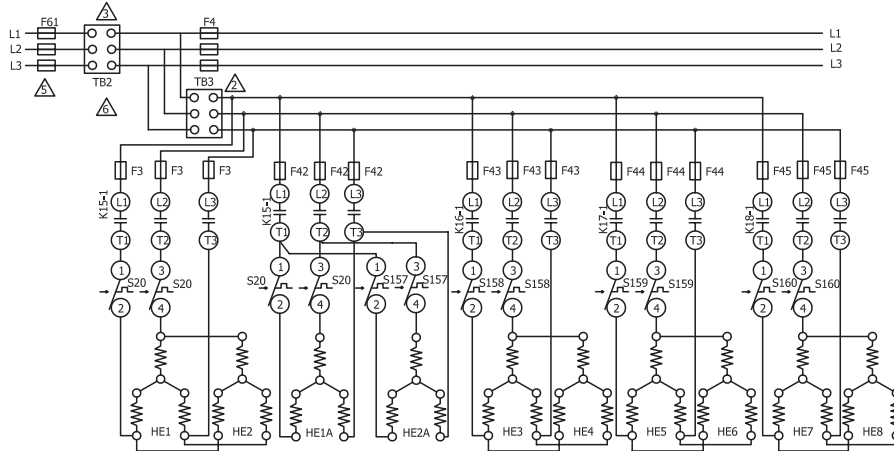

CHASSIS	KW	HE1	HE1A	HE2	HE2A	HE3	HE4	HE5	HE6	HE7	HE8
C	15		7.5		7.5						
D	20		10		10						
CD	30		15		15						
D	40		20		20						
CD	45	15				7.5		15		7.5	
CD	60	15				15		15		15	
D	80	20			20	20		20		20	
CD	90	15				15	15	15		15	15
D	120	15	15			15	15	15	15	15	15

2024/07
WIRING DIAGRAM
07/24

538126-03

HEATING

ELECTRIC HEAT LCT/LHT/LCX/LHX
E1EH,EHA-15, 20, 30, 40, 45,60, 80, 90, 120 - G, J

SECTION A

Supersedes 538126-02

REV.0

New Form No.
538126-03

EHA-15/90 Y VOLTAGE

J/P	JACK/PLUG
7	ELECTRIC HEAT CONTROL
37	ELECTRIC HEAT CONTROL

KEY	DESCRIPTION
A55	CONTROL, BOARD LENNOX
A178	BOARD, COMP 3 & 4, C3 2nd STAGE HEAT
F3	FUSE, ELECTRIC HEAT
F4	FUSE, UNIT
F42	FUSE, ELECTRIC HEAT 1 A, 2A
F43	FUSE, ELECTRIC HEAT 3
F44	FUSE, ELECTRIC HEAT 4

F45	FUSE, ELECTRIC HEAT 5
F46	FUSE, ELECTRIC HEAT 6
F49	FUSE, ELECTRIC HEAT 7
F50	FUSE, ELECTRIC HEAT 8
F61	FUSE, UNIT - SCOR
HE1	ELEMENT, ELECTRIC HEAT 1
HE2	ELEMENT, ELECTRIC HEAT 2
HE3	ELEMENT, ELECTRIC HEAT 3
HE4	ELEMENT, ELECTRIC HEAT 4
HE5	ELEMENT, ELECTRIC HEAT 5
HE6	ELEMENT, ELECTRIC HEAT 6
HE7	ELEMENT, ELECTRIC HEAT 7
HE8	ELEMENT, ELECTRIC HEAT 8
HE9	ELEMENT, ELECTRIC HEAT 9
HE10	ELEMENT, ELECTRIC HEAT 10
HE11	ELEMENT, ELECTRIC HEAT 11
HE12	ELEMENT, ELECTRIC HEAT 12
HE13	ELEMENT, ELECTRIC HEAT 13
HE14	ELEMENT, ELECTRIC HEAT 14
K9-1	RELAY, HEAT
K15-1	CONTACTOR, ELECTRIC HEAT 1,2
K16-1	CONTACTOR, ELECTRIC HEAT 1A,2A
K17-1	CONTACTOR, ELECTRIC HEAT 3,4
K18-1	CONTACTOR, ELECTRIC HEAT 5,6
K242	CONTACTOR, ELECTRIC HEAT 1
K243	CONTACTOR, ELECTRIC HEAT 2
K244	CONTACTOR, ELECTRIC HEAT 3
K245	CONTACTOR, ELECTRIC HEAT 4
S15	SWITCH, LIMIT PRIMARY ELECTRIC HEAT
S20	SWITCH, LIMIT SECONDARY ELECTRIC HEAT 1,2
S107	SWITCH, PRIMARY ELECTRIC HEAT
S157	SWITCH, LIMIT SECONDARY ELECTRIC HEAT 2
S158	SWITCH, LIMIT SECONDARY ELECTRIC HEAT 3
S159	SWITCH, LIMIT SECONDARY ELECTRIC HEAT 4
S160	SWITCH, LIMIT SECONDARY ELECTRIC HEAT 5
S161	SWITCH, LIMIT SECONDARY ELECTRIC HEAT 6
S171	SWITCH, LIMIT SECONDARY ELECTRIC HEAT 7
S172	SWITCH, LIMIT SECONDARY ELECTRIC HEAT 8
TB2	TERMINAL STRIP, UNIT
TB3	TERMINAL STRIP, ELECTRIC HEAT

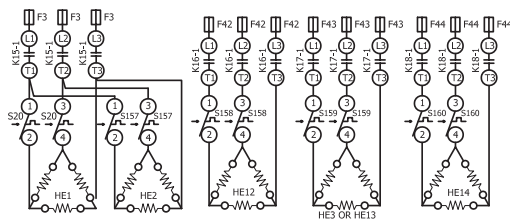
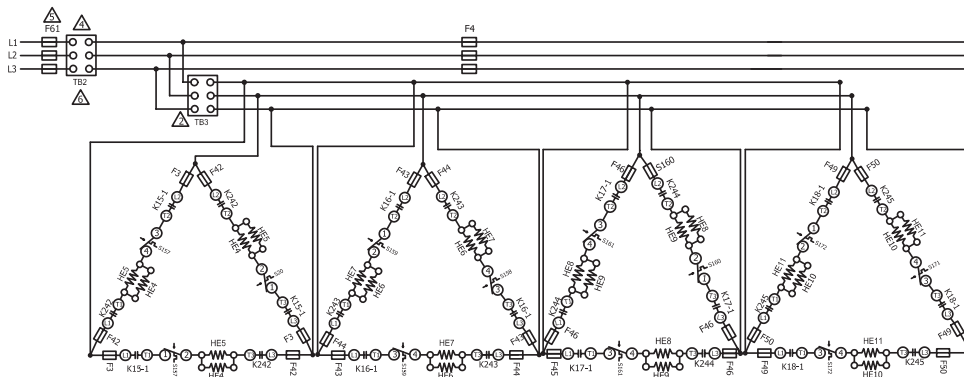
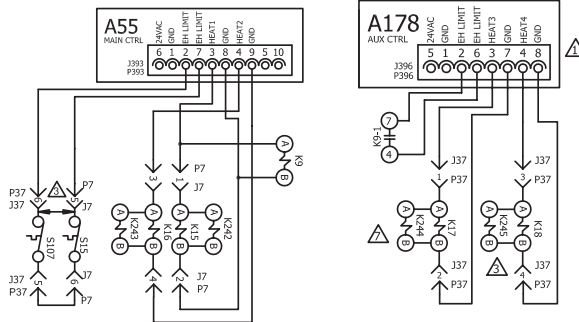

- | DESIGNATION | VOLTAGE |
|-------------|------------------|
| Y | 208-230/60/3 |
| C | UNITS 156 TO 300 |
| D | UNITS 240 TO 360 |
- ⚠ NOT USED ON 15 AND 30KW UNITS
 - ⚠ TB3 IS USED IN SOME UNITS
 - ⚠ REMOVE PLUG WHEN FIELD INSTALLING ELECTRIC HEAT
 - ⚠ TB2, CB10 OR S48 MAY BE USED ON NON SCOR UNITS
 - ⚠ F61 USED ON SCOR OPTION UNITS ONLY
 - ⚠ TB2 IS USED IN SOME SCOR OPTION UNITS ONLY
 - ⚠ ONLY USED ON 120 kW D-BOX UNITS
- ← DENOTES OPTIONAL COMPONENTS

CHASSIS	KW	HE1	HE2	HE3	HE4	HE5	HE6	HE7	HE8	HE9	HE10	HE11	HE12	HE13	HE14
C	15	7.5	7.5												
C.D	30				15	15									
C.D	45	15										7.5	15	7.5	
C.D	60	15								15	15	15	15	15	
C.D	90	15		15											
D	120			15	15	15	15	15	15	15	15	15	15	15	

2024/03
WIRING DIAGRAM
03/24

538127-02

HEATING

ELECTRIC HEAT

E1EH, EHA - 15, 30, 45, 60, 90, 120 - Y

SECTION A
REV 0

Supersedes
538127-01
New Form No.
538127-02

SEQUENCE OF OPERATION - MSAV® MULTI-STAGE AIR VOLUME

Objective: Outline the unit functions as a result of room thermostat or zone sensor demands.

Given: When economizer is present, it will function as an integral part of the unit cooling system. When not present, unit will function as if economizer is present but outdoor ambient is high and sensed as not suitable.

UNIT OPERATION WITH 2-STAGE THERMOSTAT (2 COOL AND 2 HEAT STAGES, Y1, Y2, W1, W2)

SUPPLY AIR BLOWER SPEED

Unit has following supply air blower speed setting:

- Ventilation speed
- Cooling Speed - Low
- Cooling Speed - High
- Heating speed
- Smoke speed (Used only in smoke removal option - not discussed)

¹ Unit Features An Economizer And Outdoor Air Is Suitable

COOLING

Y1 Demand:

All compressors are off, supply air blower is on low cooling speed to minimize blower power consumption, economizer modulates (minimum to maximum open position) to maintain 55°F supply air temperature (default unit controller setting).

Y2 Demand:

All compressors are off, supply air blower is on high cooling speed providing higher cooling capacity, and economizer modulates to maintain 55°F supply air temperature. If economizer stays at maximum open for 3 minutes, compressor 1 is energized while supply air blower stays on high cooling speed providing maximum cooling capacity.

¹ Outdoor air suitability is determined by the energy state of outdoor ambient (enthalpy or sensible) and its ability to achieve the desired free cooling effects. Outdoor air suitability can also be determined by a third party controller and provided to the rooftop unit via a network connection.

Unit Does Not Feature An Economizer Or Outdoor Air Is Not Suitable

Cooling - Thermostat Mode (Y1, Y2)

Y1 Demand:

Compressor 1 operates, and supply air blower operates at low cooling speed.

Y2 Demand:

All compressors operate and supply air blower operates at high cooling speed.

SEQUENCE OF OPERATION - MSAV® MULTI-STAGE AIR VOLUME

UNIT OPERATION WITH 3-STAGE THERMOSTAT OR ZONE SENSOR (3 COOL AND 2 HEAT STAGES, Y1, Y2, Y3 AND W1, W2)

SUPPLY AIR BLOWER SPEED

Unit has following supply air blower speed setting:

- Ventilation speed
- Cooling Speed - Low
- Cooling Speed - High
- Heating speed
- Smoke speed (Used only in smoke removal option - not discussed)

¹ Unit Features An Economizer And Outdoor Air Is Suitable

COOLING

Y1 Demand:

All compressors are off, supply air blower is on low cooling speed to minimize blower power consumption, economizer modulates (minimum to maximum open position) to maintain 55°F supply air temperature (default unit controller setting).

Y2 Demand:

All compressors are off, supply air blower is on high cooling speed providing higher cooling capacity, and economizer modulates to maintain 55°F supply air temperature. If economizer stays at maximum open for 3 minutes, compressor 1 is energized while supply air blower stays on high cooling speed. After compressor 1 is energized the economizer stays at maximum open.

Y3 Demand:

Compressors 1 and 2 are energized while supply air blower stays on high cooling speed.

¹ Outdoor air suitability is determined by the energy state of outdoor ambient (enthalpy or sensible) and its ability to achieve the desired free cooling effects. Outdoor air suitability can also be determined by a third party controller and provided to the rooftop unit via a network connection.

Unit Does Not Feature An Economizer or Outdoor Air Is Not Suitable

Cooling - Thermostat or Zone Sensor Mode (Y1, Y2, Y3)

Y1 Demand:

Compressor 1 is energized, and supply air blower operates at low cooling speed.

Y2/Y3 Demand:

All compressors are energized and supply air blower operates at high cooling speed.

DEFROST

Coil Sensors (RT48 - Circuit 1 and RT49 - Circuit 2) and Ambient Sensor (RT17) provides input to the Lennox® CORE Lite Unit Controller to initiate a defrost cycle if needed.

Coil sensors are located on a return bend for each circuit on the front of the outdoor coil.

Ambient sensor is located on the inside of the corner mullion on the back of the outdoor coil section.

If a coil sensor measures a temperature below 35°F during mechanical heating mode, defrost logic is enabled. The system will constantly monitor coil and ambient temperatures and will initiate a defrost cycle if the controller determines that the target temperature difference between the coil and ambient temperature has been satisfied, or when the accumulated run time with coil temperature below 35°F reaches 6 hours.

Defrost will not be activated on more than one circuit at the time.

If the ambient sensor fails, or the circuit is in uncalibrated state, the controller will switch to time/temperature defrost operation.

If the unit is equipped with Electric heat, then the modules are energized during a defrost cycle to maintain discharge air temperature.

SEQUENCE OF OPERATION - MSAV® MULTI-STAGE AIR VOLUME

HEATING

Thermostat or Zone Sensor

W1/H1 Demand:

A first-stage heating demand (W1/H1) will energize compressors 1 and 2 and the outdoor fans.

NOTE – L1 & L2 reversing valves are de-energized in the heating mode.

Units With Optional Electric Heat:

An increased heating demand (W2/H2) will energize electric heat.

NOTE – Compressors 1 and 2 stay energized.

Units With Optional 2 Stage Electric Heat and Zone Sensor mode:

An increased heating demand (H2) will energize 1st stage of electric heat.

An increased heating demand (H3) will energize 2nd stage of electric heat.

NOTE – Compressors 1 and 2 stay energized.

All Electric heat modules are energized during the defrost cycle (W1) to temper discharge air temperature.

ACCESSORIES

Modulating Outdoor Air Damper

The minimum damper position for “occupied low blower” and “occupied high blower” is adjusted during unit setup to provide minimum fresh air requirements per ASHRAE 62.1 at the corresponding supply air blower speeds.

- When supply air blower is off or the unit is in unoccupied mode, the outdoor air damper is closed.
- When unit is in occupied mode and supply air blower is operating at a speed below the “midpoint” blower speed, the outdoor air damper is at minimum “low blower” position.
- When unit is in occupied mode and supply air blower is operating at a speed equal to or above the “midpoint” blower speed, the outdoor air damper is at minimum “high blower” position.

NOTE - The “midpoint” blower speed is an average of the minimum and maximum blower speed (minimum speed + maximum speed divided by 2).

Power Exhaust Operation

NOTE - POWER EXHAUST OPERATION IS THE SAME FOR ALL CONTROL OPTIONS

MSAV® models are equipped with 2-stage power exhaust fans. Power exhaust fans operate when economizer outdoor air dampers are 50% open (adjustable). Power exhaust operates in 1st stage (one fan) up to 70% of supply air blower speed. 2nd stage power exhaust fans (both fans) operate when supply air blower speed is above 70% (adjustable) of full speed.

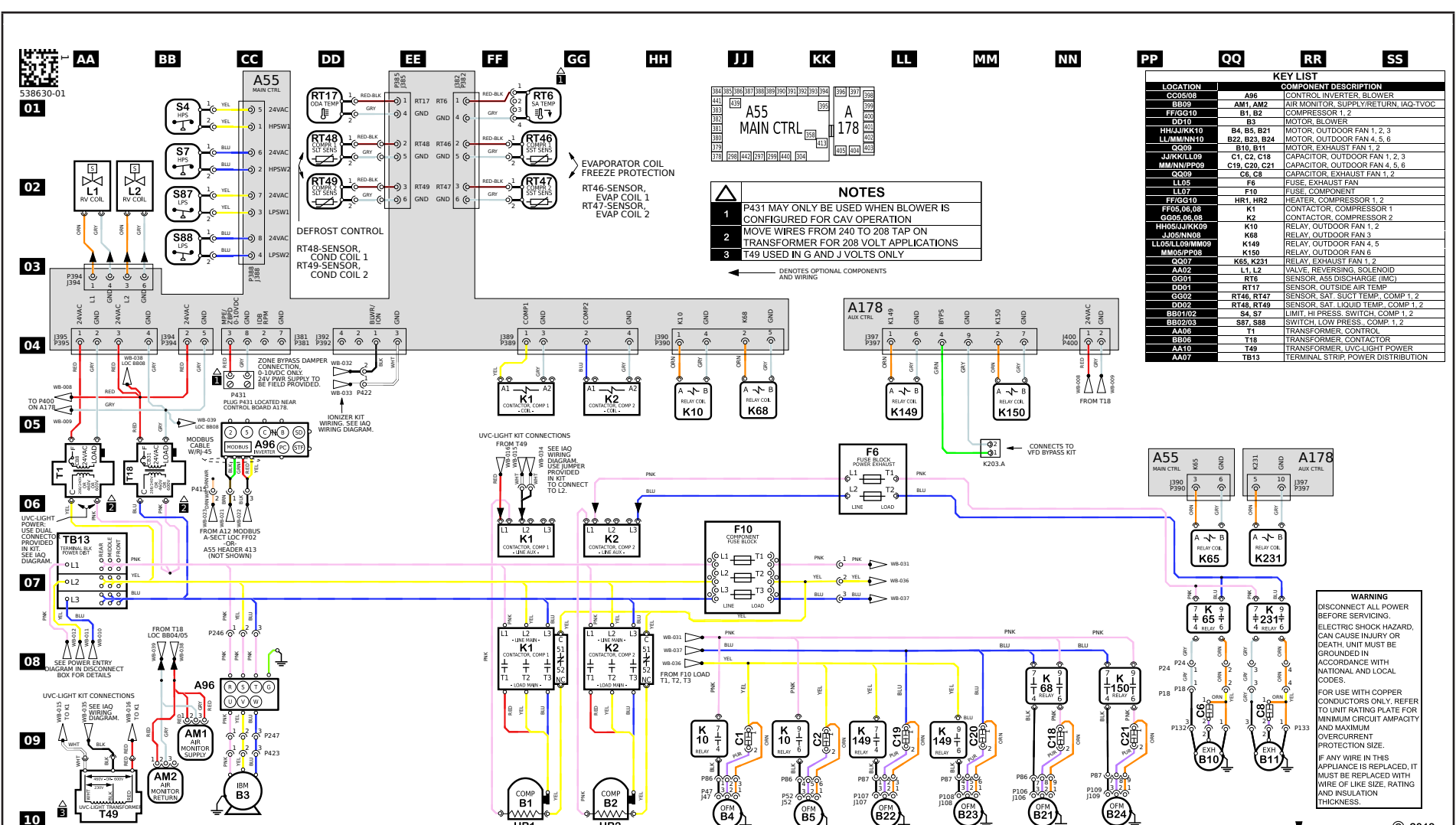

KEY LIST	
LOCATION	COMPONENT DESCRIPTION
CC05/05	A96 CONTROL INVERTER BLOWER
BB09	AM1, AM2 AIR MONITOR, SUPPLY/RETURN, IAQ-TVOC
FF/GG10	B1, B2 COMPRESSOR 1, 2
DD10	B3 MOTOR, BLOWER
HH/JJ/KK/LL/MM/NN10	B4, B5, B21 MOTOR, OUTDOOR FAN 1, 2, 3
LL/MM/NN10	B22, B23, B24 MOTOR, OUTDOOR FAN 4, 5, 6
CC09	B10, B11 MOTOR, EXHAUST FAN 1, 2
JJ/KK/LL09	C1, C2, C18 CAPACITOR, OUTDOOR FAN 1, 2, 3
MM/NN/PP09	C19, C20, C21 CAPACITOR, OUTDOOR FAN 4, 5, 6
QQ09	C6, C8 CAPACITOR, EXHAUST FAN 1, 2
LL05	F6 FUSE, EXHAUST FAN
LL07	F10 FUSE, COMPONENT
FF/GG10	HR1, HR2 HEATER COMPRESSOR 1, 2
FF09, GG10	K1 CONTACTOR, COMPRESSOR 1
GG05, GG08	K2 CONTACTOR, COMPRESSOR 2
HH05/JJ/KK09	K10 RELAY, OUTDOOR FAN 1, 2
JJ05/NN08	K68 RELAY, OUTDOOR FAN 3
LL05/LL09/MM09	K149 RELAY, OUTDOOR FAN 4, 5
MM05/PP08	K150 RELAY, OUTDOOR FAN 6
QQ07	K65, K231 RELAY, EXHAUST FAN 1, 2
AA102	L1, L2 VALVE, REVERSING, SOLENOID
AA102	RT6 SENSOR, ASS DISCHARGE (IMC)
DD01	RT17 SENSOR, OUTSIDE AIR TEMP
GG02	RT46, RT47 SENSOR, SAT. SUCT. TEMP., COMP 1, 2
DD02	RT48, RT49 SENSOR, SAT. LIQUID TEMP., COMP 1, 2
BB01/02	S4, S7 LIMIT, HI PRESS. SWITCH, COMP. 1, 2
BB02/03	S87, S88 SWITCH, LOW PRESS., COMP. 1, 2
AA105	T1 TRANSFORMER, CONTROL
AA110	T18 TRANSFORMER, CONTACTOR
AA107	T49 TRANSFORMER, UVC-LIGHT POWER
AA07	TB13 TERMINAL STRIP, POWER DISTRIBUTION

- NOTES**
- P431 MAY ONLY BE USED WHEN BLOWER IS CONFIGURED FOR CAV OPERATION
 - MOVE WIRES FROM 240 TO 208 TAP ON TRANSFORMER FOR 208 VOLT APPLICATIONS
 - T49 USED IN G AND J VOLTS ONLY
- ⚠ DENOTES OPTIONAL COMPONENTS AND WIRING

WARNING
DISCONNECT ALL POWER BEFORE SERVICING.
ELECTRIC SHOCK HAZARD, CAN CAUSE INJURY OR DEATH. UNIT MUST BE GROUNDED IN ACCORDANCE WITH NATIONAL AND LOCAL CODES.
FOR USE WITH COPPER CONDUCTORS ONLY. REFER TO UNIT RATING PLATE FOR MINIMUM CIRCUIT AMPACITY AND MAXIMUM OVERCURRENT PROTECTION SIZE.
IF ANY WIRE IN THIS APPLIANCE IS REPLACED, IT MUST BE REPLACED WITH WIRE OF LIKE SIZE, RATING AND INSULATION THICKNESS.

Model: LHX 3005 - G, J, Y VOLT
MSAV 2 COMPRESSORS 6 CONDENSER FANS

Voltage: 460V/3~60Hz (G), 575V/3~60Hz (J), 208-240V/3~60Hz (Y)
Supersedes: N/A Form No: 538630-01 Rev: 1

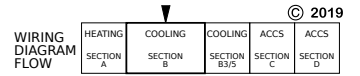

10x17
CUT SIZE

REV	EC NO.	DATE	BY	APVD	REVISION NOTE
---	CN-013691B	08-06-2025	DEV	AL21	ORIGINATED AT PD&R CARROLLTON, TX
001	CN-013691D	11-03-2025	DEV	AL21	OD FAN HARNESS CIRCUIT UPDATED WITH ADDITIONAL RELAYS K68 & K150 AT LOCATION JJ05, MM05, NN08 AND PP08