

LGX

K-Series™ ROOFTOP UNITS

Standard Efficiency | Intelli-Guide™ Controller | Eco-Last™ Coil | **R-454B** | 60Hz

COMMERCIAL
PRODUCT SPECIFICATIONS (EHB)



7.5 to 12.5 Tons

Net Cooling Capacity | 88,000 to 138,000 Btuh
Gas Input Heat Capacity | 130,000 to 240,000 Btuh

K-SERIES™



MODEL NUMBER IDENTIFICATION

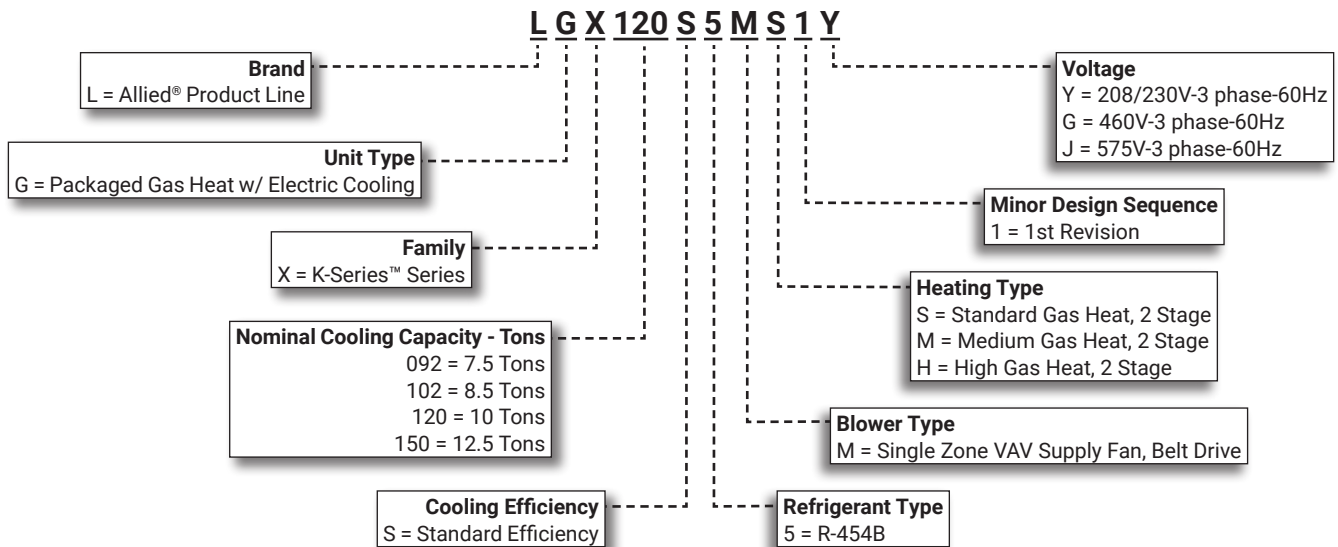

FEATURE HIGHLIGHTS

K-Series rooftop units are engineered with the right technologies and options to meet standard efficiency requirements while delivering reliable performance and year-round comfort.

1. Heat Exchanger/Inshot Burners
2. Scroll Compressors
3. Eco-Last™ Coil System
4. Outdoor Coil Fan Motors
5. Heavy Gauge Steel Cabinet
6. Single Zone VAVBlower
7. Air Filter
8. Intelli-Guide™ 2.0 Lite Control System

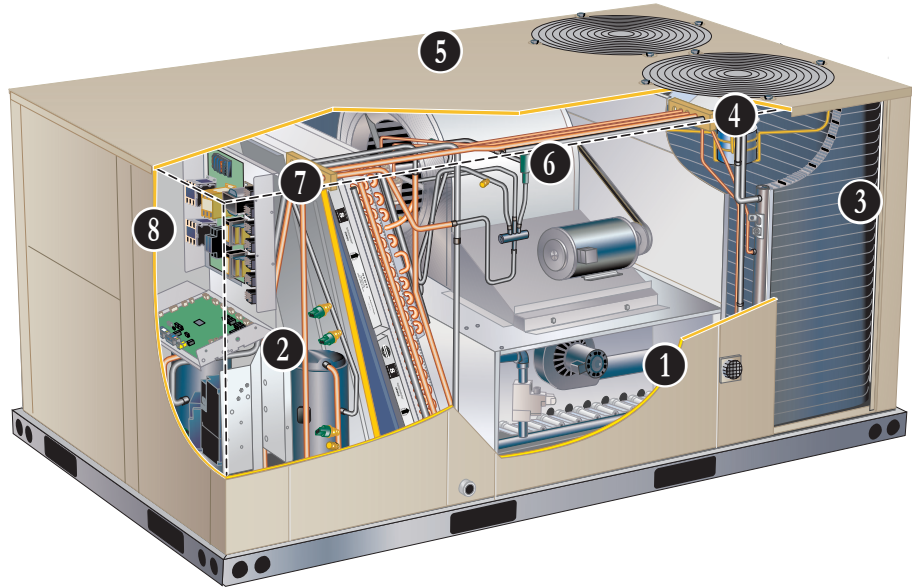

CONTENTS

Approvals And Warranty	3
Blower Data	28
- Belt Drive - 7.5 8.5 Ton	28
- Belt Drive - 10 12.5 Ton	29
Dimensions	36
- Accessories	37
- Unit	36
Electrical Data	32
- 7.5 Ton	32
- 8.5 Ton	32
- 10 Ton	33
- 12.5 Ton	33
Features And Benefits	3
High Altitude Derate	21
Dehumidification System Option	16
Dehumidification System Ratings	26
Model Number Identification	1
Optional Conventional Temperature Control Systems	12
Options / Accessories	17
Outdoor Sound Data	34
Ratings	22
Sequence Of Operation	14
Specifications	20
- Gas Heat	21
- Unit	20
Unit Clearances	34
Weight Data	35

APPROVALS AND WARRANTY

APPROVALS

- AHRI Standard 340/360-2023 certified
- ETL and CSA listed
- Unit and components are ETL, NEC, and CEC bonded for grounding to meet safety standards for servicing
- All models are ASHRAE 90.1 compliant
- All models meet DOE 2023 energy efficiency standards and UL 60335-2-40 Refrigerant Detector Requirements
- All models have HCAI (formerly OSHPD) OSP and Special Seismic Certification ([Number: OSP-0596](#)), and meet 2021 International Building Code (IBC), 2022 California Building Code (CBC) ASCE 7, and ICC-ES AC156
- A models meet California Code of Regulations, Title 24 and ASHRAE 90.1 Section 6.4.3.10 requirements for staged airflow
- ISO 9001 Registered Manufacturing Quality System

WARRANTY

- Aluminized Heat Exchanger - Limited ten years
- Stainless Steel Heat Exchanger (optional) - Limited fifteen years
- Compressors - Limited five years
- Eco-Last™ Coil System - Limited three years
- Intelli-Guide™2.0 Lite Unit Controller - Limited three years
- Variable-Frequency Drive (VFD) - Limited five years
- High Performance Economizers (optional) - Limited five years
- All other covered components - Limited one year

FEATURES AND BENEFITS

HEATING SYSTEM

- 1 • Aluminized steel inshot burners
- Direct spark ignition
- Electronic flame sensor
- Combustion air inducer
- Redundant automatic dual stage gas valve with manual shut-off

Heat Exchanger

- Tubular construction, aluminized steel
- Life-cycle tested

NOTE - Optional Stainless Steel Heat Exchanger is required if mixed air temperature is below 45°F.

Electronic Pilot Ignition

- Electronic spark igniter provides positive direct ignition of burners on each operating cycle
- Permits main gas valve to stay open only when the burners are proven to be lit
- If loss of flame occurs, gas valve closes, shutting off the gas to the burners
- LED indicates status and aids in troubleshooting
- Watchguard circuit on module automatically resets ignition controls after one hour of continuous thermostat demand after unit lockout, eliminating nuisance service calls
- Factory installed in the gas heating compartment

Limit Controls

- Redundant limit controls with fixed temperature setting
- Protects heat exchanger and other components from overheating

Safety Switches

- Flame roll-out switch
- Flame sensor
- Combustion air inducer proving switch
- Protects system operation

Required Selections

Gas Input Choice - Order one:

- Standard Gas Heat, 2 Stage (84,500/130,000 Btuh)
- Medium Gas Heat, 2 Stage (117,000/180,000 Btuh)
- High Gas Heat, 2 Stage (156,000/240,000 Btuh)

Options/Accessories

Factory Installed

Stainless Steel Heat Exchanger

- Required if mixed air temperature is below 45°F

Field Installed

Bottom Gas Piping Kit

- Allows bottom gas entry
- Factory installed kit is furnished with the unit for field installation

Low Temperature Vestibule Heater

- Electric heater automatically controls minimum temperature in gas burner compartment when temperature is below -40°F
- CSA certified to allow operation of unit down to -60°F

FEATURES AND BENEFITS

HEATING SYSTEM (continued)

Options/Accessories

Field Installed

Combustion Air Intake Extensions

- Recommended for use with existing flue extension kits in areas where high snow areas can block intake air

LPG/Propane Kits

- Conversion kit to field change over units from Natural Gas to LPG/Propane

Vertical Vent Extension Kit

- Use to exhaust flue gases vertically above unit
- Required when unit vent is too close to fresh air intakes per building codes
- Also prevents ice formation on intake louvers
- Kit contains vent transition, vent tee, drain cap, and installation hardware

NOTE - Straight vent pipes (4 in. B-Vent) and caps are not furnished and must be field supplied. Refer to kit instructions for additional information.

COOLING SYSTEM

- Designed to maximize sensible and latent cooling performance at design conditions
- System can operate from 45°F to 125°F without any additional controls

R-454B Refrigerant

- Low GWP (Global Warming Potential)
- Zero ODP (Ozone Depletion Potential)
- Low Toxicity/Lower Flammability - A2L
- Unit is factory pre-charged

2 Compressor System

- System consists of one two-stage scroll compressor and one single-stage scroll compressor
- Resiliently mounted on rubber grommets for quiet operation

Compressor Crankcase Heaters

- Protects against refrigerant migration that can occur during low ambient operation or during extended off cycles

Thermal Expansion Valves

- Ensures optimal performance throughout the application range
- Removeable power element

Filter/Driers

- High capacity filter/drier protects the system from dirt and moisture

High Pressure Switches

- Protects the compressor from overload conditions such as dirty condenser coils, blocked refrigerant flow or loss of outdoor fan operation

Low Pressure Switches

- Protects the compressors from low pressure conditions such as low refrigerant charge or low/no airflow

Indoor Coil Freeze Protection

- Protects the evaporator coil from damaging ice build-up due to conditions such as low/no airflow or low refrigerant charge

3 Condenser Coil - Eco-Last™ Coil System

- Lightweight, all aluminum brazed fin construction
- Constructed of three components
 - A flat extrusion tube
 - Fins in-between the flat extrusion tube
 - Two refrigerant manifolds

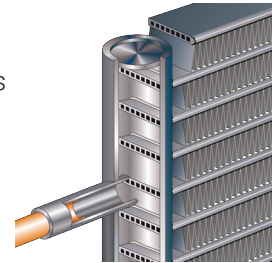

Eco-Last™ Coil System Features:

- Improved heat transfer performance due to high primary surface area (flat tubes) versus secondary surface (fins)
- Smaller internal volume (reduced refrigerant charge)
- High durability
- All aluminum construction
- Fewer brazed joints
- Compact design
- Reduced unit weight
- Easy maintenance/cleaning
- Mounting brackets with rubber inserts secure coil to unit providing vibration dampening and corrosion protection

Evaporator Coil

- Copper tube construction
- Enhanced rippled-edge aluminum fins
- Flared shoulder tubing connections
- Silver soldered construction
- Factory leak tested
- Cross-row circuiting with rifled tubing

Antimicrobial Condensate Drain Pan

- Composite pan, sloped to meet drainage requirements of ASHRAE 62.1
- Antimicrobial additive resists growth of mold and mildew on drain pan, which improves indoor air quality and reduces drain line blockage
- Side or bottom drain connections
- Reversible to allow connection at back of unit

4 Outdoor Coil Fan Motors

- Thermal overload protected
- Totally enclosed
- Permanently lubricated ball bearings
- Shaft up
- Wire basket mount

Outdoor Coil Fans

- PVC coated fan guard furnished

FEATURES AND BENEFITS

COOLING SYSTEM (continued)

Required Selections

Cooling Capacity

- Specify nominal cooling capacity

Options/Accessories

Field Installed

Condensate Drain Trap

- Available in copper or PVC

Drain Pan Overflow Switch

- Monitors condensate level in drain pan
- Shuts down unit if drain becomes clogged

Low Ambient Controls (0°F)

- Units operate satisfactorily down to 45°F outdoor air temperature without any additional controls
- Allows unit operation down to 0°F without evaporator coil icing
- Head pressure speed control reduces outdoor fan operation during low ambient conditions unit head pressure rises to the setpoint
- Pressure transducers are mounted on the liquid lines
- Liquid line pressure switches and temperature switches are provided for field installation
- Wiring harnesses are furnished for simple plug-in wiring to fans and controller

LOW GWP REFRIGERANT DETECTION SYSTEM (RDS)

- Complies with UL 60335-2-40 approved standard
- Required for all systems using R-454B refrigerant
- Factory installed on all units
- Consists of a refrigerant detection sensor(s) and a mitigation control
- Ensures safe operation for systems equipped with R-454B refrigerant
- Sensor(s) monitors indoor coil area for R-454B refrigerant
- If R-454B refrigerant is detected the refrigerant detection system will prevent compressor and heating operation until R-454B refrigerant is no longer detected
- Refrigeration detection system energizes blower if any R-454B refrigerant is detected to mitigate any concentrations of refrigerant from the unit and the system

CABINET

5 Construction

- Heavy-gauge steel panels
- Full perimeter heavy-gauge galvanized steel base rail
- Base rails have rigging holes
- Three sides of the base rail have forklift slots
- Raised edges around duct and power entry openings in the bottom of the unit for water protection

Airflow Choice

- Units are shipped in downflow (vertical) return air flow configuration

NOTE - Units can be field converted to horizontal airflow with optional Horizontal Discharge Kit.

Duct Flanges

- Provided for horizontal duct attachment

Power/Gas Entry

- Electrical and gas lines can be routed through the unit base or through horizontal access knock-outs

Exterior Panels

- Constructed of heavy-gauge, galvanized steel
- Textured pre-paint with polyurethane finish
- Cyclic salt fog and UV exposure up to 1,680 hours per ASTM D5894

Insulation

- Fully insulated with non-hygroscopic fiberglass insulation (conditioned areas)
- Unit base is fully insulated
- Base insulation serves as an air seal to the roof curb, eliminating the need to add a seal during installation

Access Panels

- Filter section
- Blower/heating section
- Compressor/controls section

Options/Accessories

Factory Installed

Hinged Access Panels

- Tool-less access
- Filter section
- Blower/heating section
- Compressor/controls section
- Panel seals and quarter-turn latching handles provide a tight air and water seal

Field Installed

Combination Coil/Hail Guards

- Heavy gauge steel frame
- Painted to match cabinet
- Expanded metal mesh protects outdoor coil

Horizontal Discharge Kit

- Consists of duct covers to block off downflow supply and return air openings for horizontal applications
- Also includes return air duct flanges for end return air when economizer is used in horizontal applications

NOTE - When configuring unit for horizontal application with economizer, a separate Horizontal Barometric Relief Damper with Hood must be ordered separately for installation in the return air duct.

FEATURES AND BENEFITS

BLOWER

A wide selection of supply air blower options are available to meet a variety of airflow requirements

6 Blower Motor

- Overload protected
- Ball bearings
- Available in several different sizes to maximize air performance

Supply Air Blower

- Forward curved blades
- Double inlet
- Blower wheel statically and dynamically balanced
- Ball bearings
- Adjustable pulley (allows speed change)
- Blower assembly slides out of unit for servicing

Single Zone VAV Supply Fan Operation

- Single Zone VAV stages the amount of airflow according to compressor stages, heating demand, and ventilation demand
- Units utilize a Variable Frequency Drive (VFD) to stage the supply air blower airflow
- VFD alters the frequency and voltage of the power supply to the blower to control blower speed
- The supply air blower has three speeds:
 1. **Low Speed** - 1st Stage Cooling
 2. **Medium Speed** - 2nd Stage Cooling
 3. **High Speed** - Full load cooling and all heat modes
- Full speed blower operation is set by adjusting the motor pulley to deliver the desired air volume
- Ventilation speed is selectable between high and low speed

NOTE - Part load airflow in cooling mode should not be set below 220 cfm/nominal full load ton to reduce the risk of evaporator coil freeze-up.

- VFD has an operational range of -40 to 125° F outdoor air ambient temperature

NOTE - Lower operating costs are obtained when the blower is operated on lower speeds.

NOTE - Variable Frequency Drive (VFD) is designed to operate on balanced, three-phase power. Operating units on unbalanced three-phase power will reduce the reliability of all electrical components in the unit. Unbalanced power is a result of the power delivery system supplied by the local utility company. Factory-installed inverters are sized to drive blower motors with an equivalent current rating using balanced three-phase power. If unbalanced three-phase power is supplied the installer must replace the existing factory-installed inverter with an inverter that has a higher current rating to allow for the imbalance. Refer to the installation instructions for additional information and replacement information.

Blower Proving Switch

- Monitors blower operation, shuts down unit if blower fails

Required Selections

- Order blower motor HP and drive kit number required when base unit is ordered
- See Drive Kit Specifications Table

FEATURES AND BENEFITS

ELECTRICAL

Marked & Color-Coded Wiring

- All electrical wiring is color-coded and marked to identify which components it is connecting

Electrical Plugs

- Positive connection electrical plugs are used to connect common accessories or maintenance parts for easy removal or installation

Phase/Voltage Detection

- Monitors power supply to assure phase is correct at unit start-up
 - If phase is incorrect, the unit will not start and an alarm code is reported to the unit controller
- Protects unit from being started with incorrect phasing which could lead to issues such as compressors running backwards
- Voltage detection monitors power supply voltage to assure proper voltage
 - If voltage is not correct (over/under voltage conditions) the unit will not start and an alarm code is reported to the unit controller

Required Selections

Voltage Choice

- Specify when ordering base unit

Options/Accessories

Factory or Field Installed

Disconnect Switch

- Accessible from outside of unit
- Spring loaded weatherproof cover
- See Options/Accessories tables for ordering information, page 18

GFI Service Outlets (2)

- 115V ground fault circuit interrupter (GFCI) type options:
 - Field installed, non-powered, field wired

Field Installed

GFI Weatherproof Cover

- Single-gang cover
- Heavy-duty UV-resistant polycarbonate case construction
- Hinged base cover with gasket

INDOOR AIR QUALITY

7 Air Filters

- Disposable 2 inch MERV 4 filters furnished as standard

Options/Accessories

Field Installed

High Efficiency Air Filters

- Disposable MERV 8, MERV 13 (Minimum Efficiency Reporting Value based on ASHRAE 52.2) efficiency 2 inch pleated filters

Replacement Filter Media Kit With Frame

- Replaces existing pleated filter media
- Includes washable metal mesh screen and metal frame with clip for holding replaceable non-pleated filter

Indoor Air Quality (CO₂) Sensors

- Monitors CO₂ levels and reports to the Unit Controller, which adjusts economizer dampers as needed

CONTROL SYSTEM

INTELLI-GUIDE™ 2.0 LITE CONTROL SYSTEM

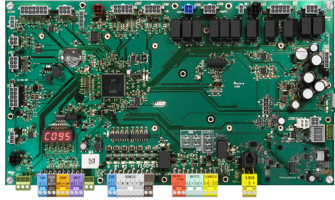

8 The Intelli-Guide™ 2.0 Lite Control system is designed to accelerate equipment install and service. Standard with all K-Series™ rooftop units, control system integrates key technologies that lower installation costs, drive system efficiency, and protect your investments.

The Intelli-Guide™ 2.0 Lite Unit Controller is a microprocessor-based controller that provides flexible control of all unit functions.

Mobile Service App

- Guided Setup with progress indicators, detailed help, and exportable summaries to manage simple, trouble-free setup, reducing commissioning times
- Enhanced Test Functionality provides real-time sensor readings, trending, and reports that enable easy troubleshooting
- Ability to set and configure parameters of the Control System to manage sequence of operation
- Economizer test function ensures economizer is operating correctly

Additional Features:

- Built-In 7-Segment Display shows Unit Status and active alarms for easy troubleshooting
- Buttons for test and clearing delays
- WireRight™ System with keyed and removable screw terminals ensure correct field wiring
- Profile setup copies key settings between units with the same configuration to reduce setup time
- USB port allows a technician to download and transfer unit information to help verify service was performed
- USB software updates on the Intelli-Guide™ 2.0 Lite Unit Controller enhance functionality without the need to change components

Configurable Built-In Functions

- Up to three distinct Cooling Airflows in Thermostat Mode
- Programmable independent heating, ventilation and cooling blower speeds
- Economizer Control Options (See Economizer / Exhaust Air / Outdoor Air sections)
- Exhaust Fan Control Modes for fresh air damper position
- Configurable Morning Warm-up
- Night Setback Mode
- Demand Control Ventilation
- Dehumidification Operation

Component Protection / Unit Safeguards:

- Compressor Time-Off Delay

- Adjustable Blower On/Off Delay
- Return Air Temperature Limit Control
- Safety Switch Input allows Controller to respond to an external safety switch trip
- Service Relay Output
- Thermostat Bounce Delay
- Smoke Alarm Mode has four choices (unit off, positive pressure, negative pressure, purge)
- “Strike Three” Protection
- Gas Valve Time Delay Between First and Second Stage
- Minimum Compressor Run Time

Control Methods / Interfaces:

- DDC and 24V Thermostat
- BACnet MS/TP (Field Option)
- S-BUS
- Zone Temperature Sensor Input
- Dehumidistat and Humidity Sensor Inputs
- Indoor Air Quality Inputs (2)
- Built-in Control Parameter Defaults
- Permanent Diagnostic Code Storage
- Field Adjustable Control Parameters (Over 100 settings)
- Multiple Configurable Digital Inputs
- LED Indicators

Intelli-Guide™ 2.0 Lite Control System features vary with the type of rooftop unit in which the control is installed.

CONTROL SYSTEM

INTELLI-GUIDE™ 2.0 LITE CONTROL SYSTEM

(continued)

Controls Options

Field Installed

Dirty Filter Switch

- Senses static pressure increase and issues alarm if necessary

Smoke Detector

- Photoelectric type
- Installed in supply air section, return air section or both sections
- Available with power board and single sensor (supply or return) or power board and two sensors (supply and return)
- Power board located in unit control compartment

OPTIONS / ACCESSORIES

ECONOMIZER

- Economizer operation is set and controlled by the Intelli-Guide™ 2.0 Lite Unit Controller
- Simple plug-in connections from economizer to control system for easy installation
- All K-Series™ rooftop units are equipped with factory installed CEC Title 24 approved sensors for outside, return and discharge air temperature monitoring

NOTE - Optional sensors may be used instead of unit sensors to determine whether outdoor air is suitable for free cooling. See the Options/Accessories table.

Factory or Field Installed

High Performance Economizer

- Approved for California Title 24 building standards
- Low leakage dampers are Air Movement and Control Association International (AMCA) Class 1A Certified - Maximum 3 CFM per sq. ft. leakage at 1 in. w.g.
- ASHRAE 90.1 compliant
- Downflow or Horizontal with Outdoor Air Hood
- Outdoor Air Hood is included when economizer is factory installed and is furnished with economizer when ordered for field installation
- Linked damper action
- High torque 24-volt fully-modulating spring return damper motor
- Return air and outdoor air dampers
- Plug-in connections to unit
- Barometric Relief Dampers with Exhaust Hood are also furnished

NOTE - Horizontal applications use furnished outdoor air hood and barometric relief dampers with exhaust hood. Requires optional Horizontal Discharge Kit. See dimension drawing on page 39.

Horizontal applications in reduced spaces requires optional Horizontal Low Profile Barometric Relief Dampers with Exhaust Hood and Horizontal Discharge Kit. See dimension drawing on page 40.

NOTE - High Performance Economizers are not approved for use with enthalpy controls in Title 24 applications.

NOTE - The Free Cooling setpoint for Title 24 applications must be set based on the Climate Zone where the system is installed. See Section 140.4 "Prescriptive Requirements for Space Conditioning Systems" of the California Energy Commission's 2022 Building Energy Efficiency Standards.

NOTE - Refer to Installation Instructions for complete setup information.

OPTIONS / ACCESSORIES

ECONOMIZER (continued)

Factory or Field Installed

Single Enthalpy Control (Not for Title 24)

- Outdoor air enthalpy sensor enables economizer if the outdoor enthalpy is less than the setpoint of the control

Field Installed

Differential Enthalpy Control (Not for Title 24)

- Order two Single Enthalpy Controls
- One is field installed in the return air section
- One is installed in the outdoor air section
- Allows the economizer control to select between outdoor air or return air, whichever has lower enthalpy

Differential Sensible Control

- Factory setting
- Uses outdoor air and return air sensors that are furnished with the unit
- The Intelli-Guide™ 2.0 Lite Unit Controller compares outdoor air and return air setpoints and activates the economizer when the outdoor air temperature is below the configured setpoint and cooler than return air

NOTE - Differential Sensible Control can be configured in the field to provide Offset Differential Sensible Control or Single Sensible Control.

In Offset Differential Sensible Control mode, the economizer is enabled if the temperature differential (offset) between outdoor air and return air reaches the configured setpoint.

In Single Sensible Control mode, the economizer is enabled when outdoor air temperature falls below the configured setpoint.

EXHAUST

Field Installed

Power Exhaust Fan

- Installs internal to unit for downflow applications only with economizer option
- Provides exhaust air pressure relief
- Interlocked to run when supply air blower is operating
- Fan runs when outdoor air dampers are 50% open (adjustable)
- Motor is overload protected
- Fan is 20 in. diameter
- Five blades
- One 1/3 HP motor

NOTE - Requires Economizer and Downflow Barometric Relief Dampers.

Horizontal Low Profile Barometric Relief Dampers

- For use when unit is configured for horizontal applications requiring an economizer in a reduced space
- Allows relief of excess air
- Aluminum blade dampers prevent blow back and outdoor air infiltration during off cycle
- Field installed in return air duct
- Bird screen and hood furnished

NOTE - Requires Horizontal Discharge Kit.

OPTIONS / ACCESSORIES

OUTDOOR AIR

Field Installed

Motorized Outdoor Air Damper

- Linked mechanical dampers
- Fully modulating spring return damper motor with plug-in connection
- 0 to 25% (fixed) outdoor air adjustable
- Installs in unit
- Outdoor air hood with bird screen included

Manual Outdoor Air Damper

- Adjustable slide damper
- Installed in unit
- Outdoor air hood with bird screen included

ROOF CURBS

Field Installed

- Nailer strip furnished (downflow only)
- Mates to unit
- US National Roofing Contractors Approved
- Shipped knocked down

Hybrid Roof Curbs, Downflow

- Interlocking tabs fasten corners together
- No tools required for assembly
- Can also be fastened together with furnished hardware
- Available in 8, 14, 18, and 24 inch heights

Adjustable Pitch Curb

- Fully adjustable pitch curbs (3/4 in. per foot in any direction) provide a level platform for rooftop units allowing flexible installations on roofs with uneven or sloped angles
- Interlocking tabs fasten corners together
- No tools required for assembly
- Hardware is furnished to connect upper curb with lower curb
- Available in 14 inch height

Adaptor Curbs (not shown)

- Curbs are regionally sourced
- Dimensions vary based upon the source

NOTE - Contact your local sales representative for a detailed cut sheet with applicable dimensions.

CEILING DIFFUSERS

Field Installed

Ceiling Diffusers (Flush or Step-Down)

- White powder coat finish on diffuser face and grilles
- Insulated UL listed duct liner
- Diffuser box has collars for duct connection
- Step-down diffusers have double deflection blades
- Flush diffusers have fixed blades
- Provisions for suspending
- Internally sealed to prevent recirculation
- Removable return air grille
- Adapts to T-bar ceiling grids or plaster ceilings

Transitions (Supply and Return)

- Used with diffusers
- Installs in roof curb
- Galvanized steel construction
- Flanges furnished for duct connection to diffusers
- Fully insulated

OPTIONAL CONVENTIONAL TEMPERATURE CONTROL SYSTEMS

CS8500 Commercial 7-Day Programmable Thermostat

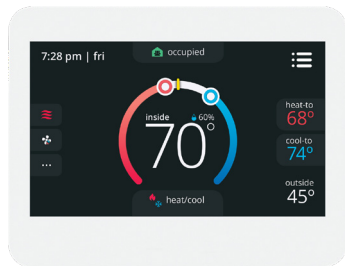

- Fully Communicating Sensor
- Full Color Touchscreen Interface
- Variable Speed System Control (On Compatible Units)
- Up To 4 Heat / 4 Cool
- Built-In Sensors For Temperature, Humidity And Optional CO₂
- Remote Sensor Options For Occupancy, Temperature
- BACnet Capable Options
- 5-2 or 7-Day Scheduling
- Smooth Setback Recovery
- Heat/Cool Auto-Changeover
- Four-Wire Installation
- FDD, ASHRAE, IECC Compliant

CS7500 Commercial 7-Day Programmable Thermostat



- Premium Universal Thermostat
- Full Color Touchscreen Interface
- Up To 4 Heat / 3 Cool
- Built-In Sensors For Temperature and Humidity
- Remote Sensors Options For Temperature, Discharge Air, Outdoor Air
- 5-2 or 7-Day Scheduling
- Smooth Setback Recovery
- Heat/Cool Auto-Changeover
- FDD, ASHRAE, IECC Compliant

CS3000 Commercial 5-2 Day Programmable Thermostat

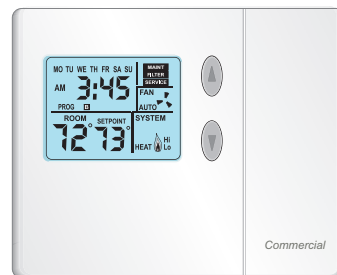

- Conventional Multi-Stage Thermostat
- Intuitive Display
- Push-Button Operation
- Up To 2 Heat / 2 Cool
- Built-In Temperature Sensor
- Remote Temperature Sensing
- Up to 5-2 Day Scheduling
- Smooth Setback Recovery
- Heat/Cool Auto-changeover

OPTIONAL CONVENTIONAL TEMPERATURE CONTROL SYSTEMS

Description	Order Number
CS8500 Commercial 7 Day Programmable Thermostat	
CS8500 7-Day Thermostat	No CO ₂ Sensing 24K55
	With CO ₂ Sensing 24K53
Sensors/Accessories	¹ Remote non-adjustable wall-mount 10k 47W37
	¹ Remote non-adjustable wall-mount 11k 94L61
Sysbus Network Cable (Yellow) for CS8500 and LCS-5030 Wired Room Sensor	
Twisted pair 100% shielded communication cable, Red and Black	500 ft. box 27M19
22 AWG, yellow jacket, rated at 75°C, 300V, Plenum rated	1000 ft. box 94L63
Insulation - Low smoke PVC, NEC, CMP	2500 ft. roll 68M25
CS7500 Commercial 7-Day Programmable Thermostat	
CS7500 7-Day Thermostat	24K41
Sensors/Accessories	² Remote non-adjustable wall-mount 20k 47W36
	² Remote non-adjustable wall-mount 10k 47W37
	Remote non-adjustable discharge air (duct mount) 19L22
	Outdoor temperature sensor X2658
CS3000 Commercial 5-2 Day Programmable Thermostat	
CS3000 5-2 Day Thermostat	11Y05
Sensors/Accessories	Remote non-adjustable wall mount 10k averaging 47W37
	Thermostat wall mounting plate X2659
Universal Thermostat Guard with Lock (clear)	
	Inside Dimensions (H x W x D) 5-7/8 x 8-3/8 x 3 in. 39P21

¹ Up to nine of the same type remote temperature sensors can be connected in parallel.

² Remote wall-mount sensors can be applied in any of the following combinations:
 One Sensor - (1) 47W36, Two Sensors - (2) 47W37, Three Sensors - (2) 47W36 and (1) 47W37
 Four Sensors - (4) 47W36, Five Sensors - (3) 47W36 and (2) 47W37

Objective: Outline the unit functions as a result of room thermostat or zone sensor demands.

Given: When economizer is present, it will function as an integral part of the unit cooling system. When not present, unit will function as if economizer is present but outdoor ambient is high and sensed as not suitable.

UNIT OPERATION WITH 2-STAGE THERMOSTAT (2 COOL AND 2 HEAT STAGES, Y1, Y2, W1, W2)

SUPPLY AIR BLOWER SPEED

Unit has following supply air blower speed setting:

- Ventilation speed
- Cooling Speed - Low
- Cooling Speed - High
- Heating speed
- Smoke speed (Used only in smoke removal option - not discussed)

¹ UNIT FEATURES AN ECONOMIZER AND OUTDOOR AIR IS SUITABLE

Cooling - Thermostat Mode (Y1, Y2)

Y1 Demand:

All compressors are off, supply air blower is on low cooling speed to minimize blower power consumption, economizer modulates (minimum to maximum open position) to maintain 55°F supply air temperature (default unit controller setting).

Y2 Demand:

All compressors are off, supply air blower is on high cooling speed providing higher cooling capacity, and economizer modulates to maintain 55°F supply air temperature.

If economizer stays at maximum open for 3 minutes, compressor 1 is energized while supply air blower stays on high cooling speed providing maximum cooling capacity.

¹ *Outdoor air suitability is determined by the energy state of outdoor ambient (enthalpy or sensible) and its ability to achieve the desired free cooling effects. Outdoor air suitability can also be determined by a third party controller and provided to the rooftop unit via a network connection.*

UNIT DOES NOT FEATURE AN ECONOMIZER OR OUTDOOR AIR IS NOT SUITABLE

Y1 Demand:

Compressor 1 operates and supply air blower operates at low cooling speed.

Y2 Demand:

All compressors operate and supply air blower operates at high cooling speed.

Dehumidification Mode

If a unit with Dehumidification Option receives a call for dehumidification, economizer free cooling is locked out.

Call For Dehumidification, No Y1, Y2 demand:

1st stage compressor operates, supply air blower operates at low cooling speed, and the reheat valve is energized.

Y1 Demand With A Call For Dehumidification:

All compressors operate, supply air blower operates at high cooling speed and the reheat valve is energized.

Y2 Demand With A Call For Dehumidification:

All compressors operate, supply air blower operates at high cooling speed, and the reheat valve is de-energized.

UNIT OPERATION WITH 3-STAGE THERMOSTAT (3 COOL AND 2 HEAT STAGES, Y1, Y2, Y3 AND W1, W2)

SUPPLY AIR BLOWER SPEED

Unit has three distinct supply air blower speeds:

- Ventilation Speed (High or Low - adjustable)
- Cooling Speed - Low
- Cooling Speed - Medium
- Cooling Speed - High
- Heating speed - High
- Smoke speed (Used only in smoke removal option - not discussed)

¹ Unit Features An Economizer And Outdoor Air Is Suitable

Cooling - Thermostat Mode (Y1, Y2, Y3)

Y1 Demand:

All compressors are off, supply air blower is on low cooling speed, economizer modulates (minimum to maximum open position) to maintain 55°F supply air temperature.

Y2 Demand:

All compressors are off, supply air blower is on high cooling speed, and economizer modulates to maintain 55°F supply air temperature. If economizer stays at maximum open for 3 minutes, compressor 1 is energized in part load while supply air blower stays on high cooling speed providing maximum cooling capacity.

Y3 Demand:

Compressor 1 operates in full load, supply air blower operates at high cooling speed, and economizers modulate to maintain 55°F supply air temperature.

¹ *Outdoor air suitability is determined by the energy state of outdoor ambient (enthalpy or sensible) and its ability to achieve the desired free cooling effects.*

Unit Does Not Feature An Economizer or Outdoor Air Is Not Suitable

Y1 Demand:

Compressor 1 operates at part load with compressor 2 OFF, and supply air blower operates at low cooling speed.

Y2 Demand:

Compressor 1 operates at part load with compressor 2 ON, and supply air blower operates at medium cooling speed.

Y3 Demand:

Compressor 1 operates at full load with compressor 2 ON, supply air blower operates at high cooling speed.

Dehumidification Mode

If a unit with Dehumidification Option receives a call for dehumidification, economizer free cooling is locked out.

Call For Dehumidification, No Y1, Y2 Demand:

1st stage compressor operates at full load, supply air blower operates at low cooling speed, and the reheat valve is energized.

Y1 Demand With A Call For Dehumidification:

Compressor 1 operates at full load with compressor 2 ON, supply air blower operates at medium cooling speed and the reheat valve is energized.

Y2 Demand With A Call For Dehumidification:

Compressor 1 operates at part load with compressor 2 ON, supply air blower operates at medium cooling speed, and the reheat valve is de-energized.

Y3 Demand With A Call For Dehumidification:

Compressor 1 operates at full load with compressor 2 ON, supply air blower operates at high cooling speed, and the reheat valve is de-energized.

HEATING MODE (GAS HEAT)

NOTE - HEATING MODE IS THE SAME FOR ALL CONTROL OPTIONS

W1 Demand:

Gas valves are open (stage 1 on units with 2-stage gas valves) and supply air blower operates at heating speed.

W2 Demand:

Gas valves are open (stage 2 on units with 2-stage gas valves) and supply air blower operates at heating speed.

POWER EXHAUST

Power exhaust blower operates when economizer outdoor air dampers are 50% open (adjustable).

DEHUMIDIFICATION SYSTEM OPTION

OVERVIEW

- Factory installed option designed to control humidity
- Provides dehumidification on demand using ASHRAE 90.1 recommended method for comfort conditioning humidity control
- Unit comes equipped with one row reheat coil, solenoid valve and humidity controller

NOTE - A dehumidification demand from a relative humidity sensor, dehumidistat, a DDC controller or building automation system is required to control humidity.

Controls are not furnished and must be ordered separately.

BENEFITS

- Improves indoor air quality
- Helps prevent damage due to high humidity levels
- Improves comfort levels by reducing space humidity levels

OPERATION

No Dehumidification Demand

- Unit will operate conventionally whenever there is a demand for cooling or heating and no dehumidification demand
- Free cooling is only permitted when there is no demand for dehumidification

Dehumidification Demand Only

- Reheat operation will initiate on a dehumidification demand and does not require a cooling demand
- Unit will operate in the dehumidification mode until the relative humidity of the conditioned space is below the setpoint
- This operation reduces sensible cooling capacity and extends compressor run time to control humidity when the cooling load is low
- A solenoid valve diverts hot gas from the compressor to the reheat coil
- Cooled and dehumidified air from the evaporator is reheated as it passes through the reheat coil
- De-superheated and partially condensed refrigerant continues to the outdoor condenser coil where condensing is completed
- Unit will continue to operate in this mode until the dehumidification demand is satisfied

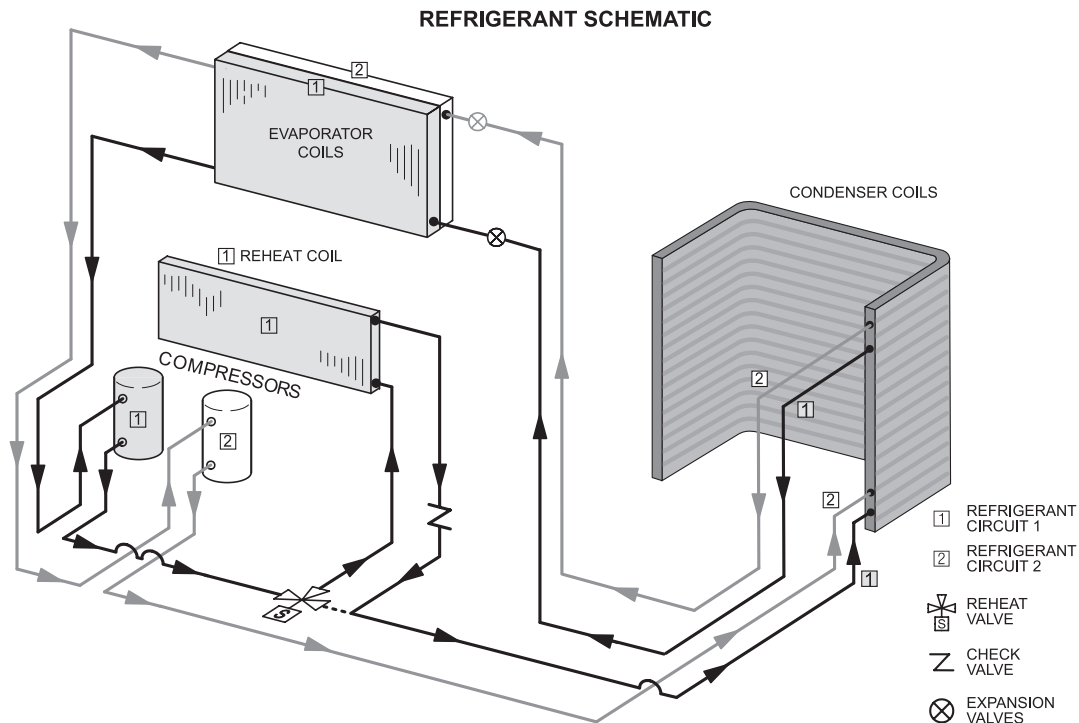

OPTIONS / ACCESSORIES

Item Description	Order Number	Size				
		092	102	120	150	
COOLING SYSTEM						
Condensate Drain Trap	PVC	22H54	X	X	X	X
	Copper	76W27	X	X	X	X
Drain Pan Overflow Switch		21Z07	X	X	X	X
Low Ambient Kit (0°F)		37P82	X	X	X	X
HEATING SYSTEM						
Bottom Gas Piping Kit		54W95	X	X	X	X
Combustion Air Intake Extensions		19W51	X	X	X	X
Gas Heat Input	130,000 Btuh	Factory	O	O	O	O
	180,000 Btuh	Factory	O	O	O	O
	240,000 Btuh	Factory	O	O	O	O
Low Temperature Vestibule Heater	208/230V-3ph	22A51	X	X	X	X
	460V	22A55	X	X	X	X
	575V	13X65	X	X	X	X
LPG/Propane Conversion Kits	Standard Heat	14N22	X	X	X	X
	Medium Heat	14N23	X	X	X	X
	High Heat	14N25	X	X	X	X
Stainless Steel Heat Exchanger		Factory	O	O	O	O
Vertical Vent Extension Kit		42W16	X	X	X	X
BLOWER - SUPPLY AIR						
Blower Motors	Belt Drive - 2 HP	Factory	O	O	O	O
	Belt Drive - 3 HP	Factory	O	O	O	O
	Belt Drive - 5 HP	Factory	O	O	O	O
Drive Kits See Blower Data Tables for selection	Kit #1 590-890 rpm	Factory	O	O	O	O
	Kit #2 800-1105 rpm	Factory	O	O	O	O
	Kit #3 795-1195 rpm	Factory	O	O	O	O
	Kit #4 730-970 rpm	Factory	O	O	O	O
	Kit #5 940-1200 rpm	Factory	O	O	O	O
	Kit #6 1015-1300 rpm	Factory	O	O	O	O
	Kit #10 900-1135 rpm	Factory	O	O	O	O
	Kit #11 1050-1335 rpm	Factory	O	O	O	O
CABINET						
Combination Coil/Hail Guards		24M51	X	X		
		24C85			X	X
Hinged Access Panels		Factory	O	O	O	O
Horizontal Discharge Kit		51W25	X	X	X	X

NOTE - Order numbers shown are for ordering field installed accessories.

OX - Configure To Order (Factory Installed) or Field Installed

O = Configure To Order (Factory Installed)

X = Field Installed

OPTIONS / ACCESSORIES

Item Description	Order Number	Size				
		092	102	120	150	
CONTROLS						
BACnet® MS/TP Module	38B35	X	X	X	X	
Dirty Filter Switch	53W67	X	X	X	X	
Smoke Detector - Supply or Return (Power board and one sensor)	31A68	X	X	X	X	
Smoke Detector - Supply and Return (Power board and two sensors)	31A69	X	X	X	X	
INDOOR AIR QUALITY						
Air Filters						
High Efficiency Air Filters 20 x 25 x 2 (Order 4 per unit)	MERV 8	50W61	X	X	X	X
	MERV 13	52W41	X	X	X	X
Replaceable Media Filter With Metal Mesh Frame (includes non-pleated filter media) (Order 4 per unit)	20 x 25 x 2	Y3063	X	X	X	X
Indoor Air Quality (CO₂) Sensors						
Sensor - Wall-mount, off-white plastic cover with LCD display		24C58	X	X	X	X
Sensor - Wall-mount, off-white plastic cover, no display		23V86	X	X	X	X
Sensor - Black plastic case, LCD display, rated for plenum mounting		87N52	X	X	X	X
Sensor - Black plastic case, no display, rated for plenum mounting		23V87	X	X	X	X
CO ₂ Sensor Duct Mounting Kit - for downflow applications		23Y47	X	X	X	X
Aspiration Box - for duct mounting non-plenum rated CO ₂ sensors (24C58)		90N43	X	X	X	X
DEHUMIDIFICATION REHEAT OPTION						
Dehumidification Option	Factory		O	O	O	O
ELECTRICAL						
Voltage 60 Hz	208/230V - 3 phase	Factory	O	O	O	O
	460V - 3 phase	Factory	O	O	O	O
	575V - 3 phase	Factory	O	O	O	O
Disconnect Switch	80 amp	54W56	OX	OX	OX	OX
GFI Service Outlets	15 amp non-powered, field-wired (208/230V, 460V only)	74M70	X	X	X	X
	² 20 amp non-powered, field-wired (208/230V, 460V, 575V)	67E01	X	X	X	X
Weatherproof Cover for GFI		10C89	X	X	X	X

¹
² Canada requires a minimum 20 amp circuit. Select 20 amp, non-powered, field wired GFI.

NOTE - Order numbers shown are for ordering field installed accessories.
OX - Configure To Order (Factory Installed) or Field Installed
O = Configure To Order (Factory Installed)
X = Field Installed

OPTIONS / ACCESSORIES

Item Description	Order Number	Size				
		092	102	120	150	
ECONOMIZER						
High Performance Economizer (Approved for California Title 24 Building Standards / AMCA Class 1A Certified)						
High Performance Economizer (Downflow or Horizontal)	20U80	OX	OX	OX	OX	
Includes Economizer Dampers with Outdoor Air Hood and Barometric Relief Dampers with Exhaust Hood						
Downflow Applications - Use furnished Outdoor Air Hood and Barometric Relief Dampers with Exhaust Hood						
Horizontal Applications - Use furnished Outdoor Air Hood and Barometric Relief Dampers with Exhaust Hood - Order Horizontal Discharge Kit separately						
Horizontal Applications (reduced height) - Order Horizontal Low Profile Barometric Relief Dampers with Exhaust Hood and Horizontal Discharge Kit (51W25) separately						
Horizontal Low Profile Barometric Relief Dampers						
Horizontal Low Profile Barometric Relief Dampers With Exhaust Hood	53K04	X	X	X	X	
Economizer Controls						
Differential Enthalpy (Not for Title 24)	21Z09	X	X	X	X	
Sensible Control	Order 2 Factory	O	O	O	O	
Single Enthalpy (Not for Title 24)	Sensor is Furnished 21Z09	OX	OX	OX	OX	
OUTDOOR AIR						
Outdoor Air Dampers With Outdoor Air Hood						
Motorized	14G28	X	X	X	X	
Manual	14G29	X	X	X	X	
POWER EXHAUST						
Standard Static	208/230V-3ph	53W44	X	X	X	X
	460V-3ph	53W45	X	X	X	X
	575V-3ph	53W46	X	X	X	X
ROOF CURBS						
Hybrid Roof Curbs, Downflow						
8 in. height	11F54	X	X	X	X	
14 in. height	11F55	X	X	X	X	
18 in. height	11F56	X	X	X	X	
24 in. height	11F57	X	X	X	X	
Adjustable Pitch Curb						
14 in. height	54W50	X	X	X	X	
CEILING DIFFUSERS						
Step-Down - Order one	RTD11-95S	13K61	X			
	RTD11-135S	13K62		X	X	
	RTD11-185S	13K63			X	
Flush - Order one	FD11-95S	13K56	X			
	FD11-135S	13K57		X	X	
	FD11-185S	13K58			X	
Transitions (Supply and Return) - Order one	C1DIFF30B-1	12X65	X			
	C1DIFF31B-1	12X66		X	X	
	C1DIFF32B-1	12X67			X	

NOTE - Order numbers shown are for ordering field installed accessories.

OX - Configure To Order (Factory Installed) or Field Installed

O = Configure To Order (Factory Installed)

X = Field Installed

SPECIFICATIONS				UNIT		
Model		LGX092S5M	LGX102S5M	LGX120S5M	LGX150S5M	
Nominal Tonnage		7.5 Ton	8.5 Ton	10 Ton	12.5 Ton	
Efficiency Type		Standard	Standard	Standard	Standard	
Blower Type		Single Zone VAV Supply Fan	Single Zone VAV Supply Fan	Single Zone VAV Supply Fan	Single Zone VAV Supply Fan	
Cooling Performance	Gross Cooling Capacity (Btuh)	89,900	101,000	119,000	143,000	
	¹ Net Cooling Capacity (Btuh)	88,000	99,000	116,000	138,000	
	¹ AHRI Rated Air Flow (cfm)	2700	3100	3200	4100	
	¹ IEER (Btuh/Watt)	14.6	14.6	14.6	14	
	¹ EER (Btuh/Watt)	11.0	11.0	11.0	10.8	
	Total Unit Power (kW)	8.0	9.0	10.5	12.8	
Sound Rating Number	dBA	88	88	90	90	
Refrigerant Charge	Refrigerant Type	R-454B	R-454B	R-454B	R-454B	
	Without Reheat Option	Circuit 1	3 lbs. 9 oz.	4 lbs. 5 oz.	3 lbs. 12 oz.	5 lbs. 2 oz.
		Circuit 2	3 lbs. 1 oz.	3 lbs. 0 oz.	4 lbs. 5 oz.	5 lbs. 15 oz.
	With Reheat Option	Circuit 1	4 lbs. 8 oz.	4 lbs. 7 oz.	5 lbs. 6 oz.	5 lbs. 3 oz.
		Circuit 2	2 lbs. 14 oz.	3 lbs. 1 oz.	4 lbs. 14 oz.	5 lbs. 13 oz.
Gas Heat Available		See page 22				
Compressor Type (Number)		Two-Stage Scroll (1), Single-Stage Scroll (1)				
Outdoor Coil	Net face area - ft. ²	20.9	20.9	28.0	27.5	
	Rows	1	1	1	1	
	Fins - in.	23	23	23	20	
Outdoor Coil Fans	Motor HP (number and type)	1/3 (2 PSC)	1/3 (2 PSC)	1/2 (2 PSC)	1/2 (2 PSC)	
	Rpm	1075	1075	1075	1075	
	Watts	740	740	1050	1050	
	Diameter (Number) - in.	(2) 24	(2) 24	(2) 24	(2) 24	
	Blades	3	3	3	3	
	Total air volume - cfm	8800	8800	9700	9700	
Indoor Coil	Net face area - ft. ²	13.54	13.54	13.54	13.54	
	Tube diameter - in.	3/8	3/8	3/8	3/8	
	Rows	3	3	4	4	
	Fins - in.	14	14	14	14	
	Condensate drain size (NPT) - in.	(1) 1				
Expansion device type		Balanced Port Thermostatic Expansion Valve, removable power element				
² Indoor Blower and Drive Selection	Nominal Motor HP	2, 3, 5				
	Maximum usable motor HP (US)	2.3, 3.45, 5.75				
	Motor - Drive kit number	2 HP Kit 1 590-890 rpm Kit 2 800-1105 rpm Kit 3 795-1195 rpm 3 HP Kit 4 730-970 rpm Kit 5 940-1200 rpm Kit 6 1015-1300 rpm 5 HP Kit 10 900-1135 rpm Kit 11 1050-1335 rpm				
	Wheel (Number) diameter x width - in.	(1) 15 X 15				
Filters	Type	MERV 4, Disposable				
	Number and size - in.	(4) 20 x 25 x 2				
Line voltage data (Volts-Phase-Hz)		208/230V-3-60 460V-3-60 575V-3-60				

NOTE - Net capacity includes evaporator blower motor heat deduction. Gross capacity does not include evaporator blower motor heat deduction.

¹ AHRI Certified to AHRI Standard 340/360; 95°F outdoor air temperature and 80°F db/67°F wb entering evaporator air; minimum external duct static pressure.

² Using total air volume and system static pressure requirements determine from blower performance tables rpm and motor output required. Maximum usable output of motors furnished are shown. In Canada, nominal motor output is also maximum usable motor output. If motors of comparable output are used, be sure to keep within the service factor limitations outlined on the motor nameplate.

NOTE – Motor service factor limit - 1.0.

SPECIFICATIONS

GAS HEAT

Heat Input Type		Standard	Medium	High	
Number of Gas Heat Stages		2	2	2	
Gas Heating Performance	Input - Btuh	1st Stage	85,000	117,000	156,000
		2nd Stage	130,000	180,000	240,000
	Output - Btuh	2nd Stage	105,000	146,000	194,000
Temperature Rise Range - °F		15 - 45	30 - 60	40 - 70	
Minimum air volume - cfm		2150	2250	2600	
¹ Thermal Efficiency		81%	81%	81%	
Gas Supply Connections		3/4 in NPT	3/4 in NPT	3/4 in NPT	
Recommended Gas Supply Pressure - Nat. / LPG		7 / 11 in. w.g.			
Gas Supply Pressure Range		Min. / Max. (Natural)	4.7 / 10.5 in. w.g.		
		Min. / Max. (LPG)	10.8 / 13.5 in. w.g.		

¹ 1 Thermal Efficiency at full input.

HIGH ALTITUDE DERATE

NOTE - Units may be installed at altitudes up to 2000 feet above sea level without any modifications.

At altitudes above 2000 feet units must be derated to match gas manifold pressures shown in table below.

At altitudes above 4500 feet unit must be derated 2% (130K through 180K) and 4% (240K) for each 1000 feet above sea level.

NOTE - This is the only permissible derate for these units.

Refer to the Installation Instructions for more detailed information.

Heat Input Type	Altitude Feet	Gas Manifold Pressure in. w.g.		Input Rate (Btuh)
		Natural Gas	LPG/ Propane	
Standard (2 stage)	2001 - 4500	1.6 / 3.4	4.4 / 9.7	85,000 / 125,000
Medium (2 stage)	2001 - 4500	1.6 / 3.4	4.4 / 9.7	117,000 / 173,000
High (2 stage)	2001 - 4500	1.6 / 3.4	4.4 / 9.7	156,000 / 221,000

RATINGS

NOTE – For Temperatures and Capacities not shown in tables, see bulletin – Cooling Unit Rating Table Correction Factor Data in Miscellaneous Engineering Data section.

7.5 TON - LGX092S5M (1 COMPRESSOR - PART LOAD)

Entering Wet Bulb Temperature	Total Air Volume	Outdoor Air Temperature Entering Outdoor Coil																			
		65°F					75°F					85°F					95°F				
		Total Cool Cap.	Comp. Motor Input	Sensible To Total Ratio (S/T)			Total Cool Cap.	Comp. Motor Input	Sensible To Total Ratio (S/T)			Total Cool Cap.	Comp. Motor Input	Sensible To Total Ratio (S/T)			Total Cool Cap.	Comp. Motor Input	Sensible To Total Ratio (S/T)		
				Dry Bulb					Dry Bulb					Dry Bulb					Dry Bulb		
cfm	kBtuh	kW	75°F	80°F	85°F	kBtuh	kW	75°F	80°F	85°F	kBtuh	kW	75°F	80°F	85°F	kBtuh	kW	75°F	80°F	85°F	
63°F	1600	44.5	1.65	0.79	0.94	1	42.8	1.87	0.8	0.96	1	41	2.19	0.82	0.98	1	39.1	2.57	0.84	1	1
	1980	46.8	1.63	0.84	1	1	45.5	1.9	0.86	1	1	43.8	2.22	0.88	1	1	41.5	2.54	0.91	1	1
	2360	49.1	1.6	0.9	1	1	47.6	1.88	0.92	1	1	45.9	2.2	0.94	1	1	43.8	2.57	0.97	1	1
67°F	1600	47	1.63	0.62	0.77	0.9	45.5	1.9	0.63	0.78	0.92	43.6	2.22	0.64	0.79	0.94	41.1	2.54	0.66	0.82	0.97
	1980	49.1	1.6	0.66	0.82	0.98	47.5	1.88	0.67	0.84	0.99	45.5	2.21	0.68	0.86	1	42.5	2.53	0.7	0.89	1
	2360	50.5	1.58	0.69	0.88	1	48.8	1.86	0.7	0.9	1	46.7	2.19	0.72	0.92	1	44.4	2.56	0.74	0.95	1
71°F	1600	49.2	1.6	0.47	0.61	0.74	47.6	1.88	0.47	0.62	0.76	45.8	2.2	0.48	0.63	0.77	43.6	2.57	0.48	0.64	0.79
	1980	51.5	1.57	0.49	0.65	0.8	49.8	1.85	0.49	0.66	0.82	47.8	2.18	0.49	0.67	0.83	45.3	2.56	0.5	0.69	0.86
	2360	53.1	1.55	0.5	0.69	0.86	51.4	1.83	0.51	0.7	0.88	49.3	2.16	0.51	0.71	0.9	46.7	2.54	0.53	0.73	0.93

7.5 TON - LGX092S5M (2 COMPRESSORS - PART LOAD / FULL LOAD)

Entering Wet Bulb Temperature	Total Air Volume	Outdoor Air Temperature Entering Outdoor Coil																			
		85°F					95°F					105°F					115°F				
		Total Cool Cap.	Comp. Motor Input	Sensible To Total Ratio (S/T)			Total Cool Cap.	Comp. Motor Input	Sensible To Total Ratio (S/T)			Total Cool Cap.	Comp. Motor Input	Sensible To Total Ratio (S/T)			Total Cool Cap.	Comp. Motor Input	Sensible To Total Ratio (S/T)		
				Dry Bulb					Dry Bulb					Dry Bulb					Dry Bulb		
cfm	kBtuh	kW	75°F	80°F	85°F	kBtuh	kW	75°F	80°F	85°F	kBtuh	kW	75°F	80°F	85°F	kBtuh	kW	75°F	80°F	85°F	
63°F	1800	71.5	4.23	0.71	0.82	0.92	67.8	4.89	0.72	0.84	0.94	64.5	5.63	0.73	0.86	0.96	60.8	6.46	0.75	0.88	0.99
	2250	76	4.19	0.74	0.87	0.98	72.4	4.85	0.76	0.89	1	68.6	5.59	0.79	0.91	1	64.5	6.42	0.81	0.94	1
	2700	79.6	4.15	0.79	0.92	1	76	4.81	0.81	0.94	1	71.7	5.55	0.83	0.97	1	67.3	6.38	0.85	0.99	1
67°F	1800	75.7	4.19	0.57	0.68	0.79	72.5	4.84	0.58	0.69	0.81	68.1	5.58	0.58	0.71	0.83	63.8	6.42	0.6	0.73	0.85
	2250	79.7	4.14	0.6	0.73	0.85	75.9	4.81	0.61	0.74	0.86	71.4	5.55	0.62	0.76	0.88	66.9	6.38	0.63	0.78	0.91
	2700	82.6	4.12	0.62	0.77	0.89	78.6	4.78	0.62	0.79	0.91	74	5.52	0.65	0.81	0.94	69.4	6.35	0.67	0.83	0.97
71°F	1800	80	4.14	0.44	0.55	0.66	76.3	4.8	0.45	0.56	0.67	72.1	5.54	0.46	0.58	0.69	67.8	6.37	0.45	0.58	0.7
	2250	84.3	4.1	0.45	0.59	0.7	80.5	4.76	0.46	0.59	0.72	75.9	5.5	0.46	0.61	0.74	71.2	6.33	0.46	0.62	0.76
	2700	87.3	4.07	0.46	0.61	0.74	83.3	4.73	0.47	0.62	0.76	78.5	5.47	0.48	0.63	0.79	73.4	6.3	0.49	0.65	0.82

7.5 TON - LGX092S5M (2 COMPRESSORS - FULL LOAD)

Entering Wet Bulb Temperature	Total Air Volume	Outdoor Air Temperature Entering Outdoor Coil																			
		85°F					95°F					105°F					115°F				
		Total Cool Cap.	Comp. Motor Input	Sensible To Total Ratio (S/T)			Total Cool Cap.	Comp. Motor Input	Sensible To Total Ratio (S/T)			Total Cool Cap.	Comp. Motor Input	Sensible To Total Ratio (S/T)			Total Cool Cap.	Comp. Motor Input	Sensible To Total Ratio (S/T)		
				Dry Bulb					Dry Bulb					Dry Bulb					Dry Bulb		
cfm	kBtuh	kW	75°F	80°F	85°F	kBtuh	kW	75°F	80°F	85°F	kBtuh	kW	75°F	80°F	85°F	kBtuh	kW	75°F	80°F	85°F	
63°F	2400	89	5.21	0.72	0.83	0.93	84.8	5.72	0.73	0.85	0.95	81.2	6.48	0.74	0.86	0.96	78.2	7.4	0.75	0.87	0.99
	3000	93.1	5.12	0.76	0.88	0.99	90.5	5.91	0.78	0.9	1	85.6	6.54	0.79	0.91	1	81.4	7.4	0.81	0.93	1
	3600	96.5	5.15	0.8	0.93	1	94	5.94	0.82	0.94	1	88.7	6.58	0.84	0.97	1	84.4	7.45	0.85	0.99	1
67°F	2400	93	5.25	0.59	0.69	0.81	88.6	5.78	0.59	0.7	0.82	84.3	6.53	0.59	0.72	0.83	80.7	7.44	0.6	0.73	0.85
	3000	96	5.17	0.61	0.75	0.86	93	5.94	0.61	0.76	0.87	87.7	6.58	0.63	0.77	0.89	83.5	7.45	0.64	0.79	0.91
	3600	98.8	5.2	0.64	0.79	0.9	96.7	5.98	0.64	0.79	0.92	90.5	6.61	0.66	0.82	0.94	86.2	7.49	0.67	0.83	0.97
71°F	2400	96.7	5.17	0.45	0.57	0.67	94.2	5.95	0.45	0.57	0.68	88.9	6.59	0.45	0.58	0.69	84.5	7.47	0.46	0.59	0.71
	3000	100.9	5.22	0.46	0.6	0.72	98.2	5.99	0.46	0.61	0.73	93.8	6.74	0.47	0.61	0.75	87.5	7.51	0.47	0.62	0.77
	3600	104.2	5.28	0.48	0.62	0.76	101.5	6.03	0.49	0.63	0.78	96.7	6.78	0.48	0.64	0.8	89.3	7.54	0.49	0.66	0.82

RATINGS

NOTE – For Temperatures and Capacities not shown in tables, see bulletin – Cooling Unit Rating Table Correction Factor Data in Miscellaneous Engineering Data section.

8.5 TON - LGX102S5M (1 COMPRESSOR - PART LOAD)

Entering Wet Bulb Temperature	Total Air Volume	Outdoor Air Temperature Entering Outdoor Coil																				
		65°F						75°F					85°F					95°F				
		Total Cool Cap.	Comp. Motor Input	Sensible To Total Ratio (S/T)			Total Cool Cap.	Comp. Motor Input	Sensible To Total Ratio (S/T)			Total Cool Cap.	Comp. Motor Input	Sensible To Total Ratio (S/T)			Total Cool Cap.	Comp. Motor Input	Sensible To Total Ratio (S/T)			
				Dry Bulb					Dry Bulb					Dry Bulb					Dry Bulb			
cfm	kBtuh	kW	75°F	80°F	85°F	kBtuh	kW	75°F	80°F	85°F	kBtuh	kW	75°F	80°F	85°F	kBtuh	kW	75°F	80°F	85°F		
63°F	1800	47.2	1.5	0.82	0.98	1	46.1	1.79	0.84	0.99	1	44.5	2.11	0.85	1	1	42.4	2.44	0.88	1	1	
	2250	50.8	1.78	0.88	1	1	48.8	1.76	0.9	1	1	47.4	2.22	0.92	1	1	45.3	2.56	0.95	1	1	
	2700	53.2	1.77	0.95	1	1	50.8	1.74	0.96	1	1	49.6	2.2	0.98	1	1	47.1	2.55	1	1	1	
67°F	1800	50.4	1.79	0.65	0.79	0.95	48.8	1.92	0.65	0.81	0.97	46.6	2.23	0.66	0.83	0.99	43.9	2.43	0.68	0.85	1	
	2250	52.5	1.77	0.69	0.86	1	50.1	1.75	0.7	0.88	1	48.7	2.21	0.71	0.9	1	46.2	2.56	0.73	0.92	1	
71°F	2700	54.2	1.76	0.73	0.92	1	51.5	1.73	0.74	0.95	1	49.3	2.04	0.76	0.97	1	47.3	2.55	0.78	0.99	1	
	1800	53	1.77	0.48	0.63	0.78	50.5	1.74	0.49	0.64	0.79	49.2	2.21	0.49	0.65	0.81	46.8	2.55	0.5	0.67	0.83	
	2250	55.4	1.75	0.51	0.68	0.84	52.5	1.72	0.5	0.69	0.86	50.3	2.03	0.52	0.71	0.89	48.3	2.54	0.53	0.72	0.9	
	2700	57	1.74	0.53	0.72	0.9	53.9	1.71	0.54	0.74	0.92	51.3	2.02	0.54	0.76	0.96	49.6	2.53	0.55	0.77	0.97	

8.5 TON - LGX102S5M (2 COMPRESSORS - PART LOAD / FULL LOAD)

Entering Wet Bulb Temperature	Total Air Volume	Outdoor Air Temperature Entering Outdoor Coil																			
		85°F					95°F					105°F					115°F				
		Total Cool Cap.	Comp. Motor Input	Sensible To Total Ratio (S/T)			Total Cool Cap.	Comp. Motor Input	Sensible To Total Ratio (S/T)			Total Cool Cap.	Comp. Motor Input	Sensible To Total Ratio (S/T)			Total Cool Cap.	Comp. Motor Input	Sensible To Total Ratio (S/T)		
				Dry Bulb					Dry Bulb					Dry Bulb					Dry Bulb		
cfm	kBtuh	kW	75°F	80°F	85°F	kBtuh	kW	75°F	80°F	85°F	kBtuh	kW	75°F	80°F	85°F	kBtuh	kW	75°F	80°F	85°F	
63°F	2040	96.5	6	0.66	0.77	0.87	93.2	6.79	0.67	0.78	0.88	88.9	7.62	0.68	0.79	0.89	84.7	8.62	0.68	0.81	0.91
	2550	102.4	6.11	0.7	0.82	0.92	98.3	6.85	0.71	0.83	0.93	94.1	7.73	0.72	0.84	0.96	89.3	8.69	0.72	0.86	0.98
	3060	106.9	6.15	0.72	0.86	0.97	103.2	6.92	0.73	0.87	0.99	98.5	7.79	0.76	0.89	1	93.4	8.77	0.78	0.91	1
67°F	2040	102.5	6.11	0.53	0.63	0.73	98.9	6.89	0.54	0.64	0.74	94.3	7.74	0.55	0.65	0.76	89	8.69	0.55	0.66	0.78
	2550	107.9	6.16	0.56	0.66	0.78	103.9	6.93	0.56	0.68	0.8	99.3	7.81	0.57	0.7	0.82	93.8	8.79	0.58	0.7	0.83
	3060	111.4	6.2	0.58	0.71	0.83	107.4	6.97	0.58	0.72	0.85	102	7.83	0.59	0.74	0.86	96.5	8.83	0.6	0.76	0.89
71°F	2040	107.3	6.15	0.42	0.52	0.61	103.4	6.93	0.42	0.52	0.61	99.2	7.82	0.42	0.52	0.62	93.9	8.79	0.43	0.54	0.64
	2550	112.9	6.21	0.43	0.54	0.65	108.8	6.98	0.44	0.54	0.66	104.1	7.87	0.44	0.55	0.67	98.5	8.86	0.44	0.57	0.68
	3060	117.3	6.29	0.44	0.56	0.68	112.6	7.04	0.45	0.57	0.69	107.7	7.92	0.45	0.58	0.7	101.7	8.92	0.45	0.59	0.73

8.5 TON - LGX102S5M (2 COMPRESSORS - FULL LOAD)

Entering Wet Bulb Temperature	Total Air Volume	Outdoor Air Temperature Entering Outdoor Coil																				
		85°F						95°F					105°F					115°F				
		Total Cool Cap.	Comp. Motor Input	Sensible To Total Ratio (S/T)			Total Cool Cap.	Comp. Motor Input	Sensible To Total Ratio (S/T)			Total Cool Cap.	Comp. Motor Input	Sensible To Total Ratio (S/T)			Total Cool Cap.	Comp. Motor Input	Sensible To Total Ratio (S/T)			
				Dry Bulb					Dry Bulb					Dry Bulb					Dry Bulb			
cfm	kBtuh	kW	75°F	80°F	85°F	kBtuh	kW	75°F	80°F	85°F	kBtuh	kW	75°F	80°F	85°F	kBtuh	kW	75°F	80°F	85°F		
63°F	2720	100.9	6.2	0.71	0.83	0.94	96.6	6.96	0.73	0.85	0.96	92.9	7.85	0.74	0.86	0.98	88.5	8.88	0.75	0.88	1	
	3400	106.6	6.3	0.75	0.89	1	102.2	7.06	0.77	0.91	1	97.8	7.93	0.78	0.93	1	92.8	8.96	0.8	0.95	1	
	4080	111.3	6.69	0.8	0.94	1	106.4	7.14	0.82	0.96	1	101.1	7.99	0.84	0.99	1	96.1	9.02	0.86	1	1	
67°F	2720	106.5	6.3	0.57	0.68	0.81	101.7	7.04	0.57	0.7	0.82	97.1	7.92	0.58	0.71	0.84	92.2	8.95	0.6	0.73	0.85	
	3400	111.9	6.7	0.6	0.74	0.86	106.4	7.12	0.61	0.75	0.88	101.1	7.99	0.62	0.77	0.9	95.8	9.02	0.63	0.78	0.92	
	4080	115.1	6.75	0.62	0.77	0.92	109.4	7.18	0.64	0.81	0.94	103.7	8.04	0.65	0.83	0.96	98.5	9.08	0.66	0.84	0.99	
71°F	2720	112.5	6.71	0.44	0.56	0.66	107.6	7.16	0.44	0.56	0.68	102.3	8.01	0.45	0.57	0.68	97.2	9.05	0.45	0.58	0.7	
	3400	117.8	6.78	0.45	0.58	0.71	112.1	7.21	0.46	0.6	0.72	106.8	8.1	0.46	0.61	0.74	101	9.13	0.47	0.62	0.76	
	4080	121.3	6.84	0.46	0.61	0.76	115.5	7.27	0.47	0.62	0.78	109.9	8.16	0.47	0.63	0.8	103.6	9.18	0.49	0.66	0.83	

RATINGS

NOTE – For Temperatures and Capacities not shown in tables, see bulletin – Cooling Unit Rating Table Correction Factor Data in Miscellaneous Engineering Data section.

10 TON - LGX120S5M (1 COMPRESSOR - PART LOAD)

Entering Wet Bulb Temperature	Total Air Volume	Outdoor Air Temperature Entering Outdoor Coil																				
		65°F						75°F					85°F					95°F				
		Total Cool Cap.	Comp. Motor Input	Sensible To Total Ratio (S/T)			Total Cool Cap.	Comp. Motor Input	Sensible To Total Ratio (S/T)			Total Cool Cap.	Comp. Motor Input	Sensible To Total Ratio (S/T)			Total Cool Cap.	Comp. Motor Input	Sensible To Total Ratio (S/T)			
				Dry Bulb					Dry Bulb					Dry Bulb					Dry Bulb			
cfm	kBtuh	kW	75°F	80°F	85°F	kBtuh	kW	75°F	80°F	85°F	kBtuh	kW	75°F	80°F	85°F	kBtuh	kW	75°F	80°F	85°F		
63°F	2110	53.4	1.62	0.8	1	1	51.9	1.9	0.81	1	1	50	2.23	0.83	1	1	47.8	2.6	0.86	1	1	
	2640	56.6	1.58	0.86	1	1	55	1.86	0.88	1	1	53	2.19	0.9	1	1	50.7	2.57	0.96	1	1	
	3170	59.1	1.56	0.95	1	1	57.3	1.85	0.98	1	1	55.2	2.18	1	1	1	52.3	2.56	1	1	1	
67°F	2110	55.7	1.59	0.63	0.78	0.95	54	1.88	0.64	0.79	0.99	51.8	2.2	0.65	0.81	1	49.2	2.59	0.67	0.84	1	
	2640	58.1	1.57	0.67	0.85	1	56.3	1.85	0.68	0.86	1	54	2.19	0.69	0.88	1	51.2	2.56	0.71	0.91	1	
71°F	2110	58	1.57	0.47	0.63	0.76	56.2	1.85	0.47	0.64	0.78	53.8	2.19	0.48	0.65	0.79	51.2	2.56	0.49	0.66	0.81	
	2640	60.4	1.54	0.49	0.67	0.83	58.5	1.84	0.5	0.68	0.84	56.1	2.17	0.51	0.69	0.86	53	2.56	0.52	0.71	0.89	
	3170	62.3	1.52	0.51	0.71	0.89	60.2	1.81	0.52	0.72	0.91	57.7	2.16	0.52	0.73	0.95	54.5	2.54	0.54	0.75	1	

10 TON - LGX120S5M (2 COMPRESSORS - PART LOAD / FULL LOAD)

Entering Wet Bulb Temperature	Total Air Volume	Outdoor Air Temperature Entering Outdoor Coil																				
		85°F						95°F					105°F					115°F				
		Total Cool Cap.	Comp. Motor Input	Sensible To Total Ratio (S/T)			Total Cool Cap.	Comp. Motor Input	Sensible To Total Ratio (S/T)			Total Cool Cap.	Comp. Motor Input	Sensible To Total Ratio (S/T)			Total Cool Cap.	Comp. Motor Input	Sensible To Total Ratio (S/T)			
				Dry Bulb					Dry Bulb					Dry Bulb					Dry Bulb			
cfm	kBtuh	kW	75°F	80°F	85°F	kBtuh	kW	75°F	80°F	85°F	kBtuh	kW	75°F	80°F	85°F	kBtuh	kW	75°F	80°F	85°F		
63°F	2400	103.9	5.87	0.66	0.78	0.89	99	6.75	0.67	0.8	0.91	93.9	7.75	0.68	0.83	0.93	86.8	9.18	0.71	0.86	0.96	
	3000	109.6	5.85	0.7	0.84	0.96	104.8	6.73	0.72	0.86	0.99	99.4	7.73	0.75	0.89	1	93.6	8.86	0.77	0.92	1	
	3600	114.7	6.04	0.75	0.9	1	109.6	6.72	0.78	0.92	1	104	7.72	0.8	0.95	1	97.8	8.85	0.83	0.98	1	
67°F	2400	109.2	6.06	0.53	0.64	0.75	105	6.72	0.54	0.64	0.76	99.3	7.72	0.54	0.66	0.79	93.2	8.85	0.55	0.67	0.83	
	3000	115.1	6.04	0.56	0.68	0.81	110	6.7	0.57	0.7	0.84	104.2	7.71	0.58	0.71	0.86	97.8	8.84	0.58	0.73	0.88	
	3600	119.2	6.04	0.57	0.72	0.87	112.9	6.94	0.6	0.74	0.89	107.6	7.7	0.6	0.77	0.92	100.9	8.82	0.61	0.81	0.95	
71°F	2400	115.7	6.03	0.4	0.52	0.61	110.2	6.94	0.41	0.52	0.62	105	7.69	0.41	0.52	0.64	98.9	8.82	0.42	0.54	0.65	
	3000	121.2	6.02	0.42	0.54	0.65	115.3	6.92	0.42	0.55	0.67	110.1	7.67	0.43	0.56	0.69	103.5	8.81	0.44	0.57	0.71	
	3600	126.3	5.8	0.43	0.57	0.69	119.3	6.93	0.43	0.58	0.72	112.7	7.95	0.44	0.59	0.75	103.6	9.74	0.44	0.62	0.78	

10 TON - LGX120S5M (2 COMPRESSORS - FULL LOAD)

Entering Wet Bulb Temperature	Total Air Volume	Outdoor Air Temperature Entering Outdoor Coil																				
		85°F						95°F					105°F					115°F				
		Total Cool Cap.	Comp. Motor Input	Sensible To Total Ratio (S/T)			Total Cool Cap.	Comp. Motor Input	Sensible To Total Ratio (S/T)			Total Cool Cap.	Comp. Motor Input	Sensible To Total Ratio (S/T)			Total Cool Cap.	Comp. Motor Input	Sensible To Total Ratio (S/T)			
				Dry Bulb					Dry Bulb					Dry Bulb					Dry Bulb			
cfm	kBtuh	kW	75°F	80°F	85°F	kBtuh	kW	75°F	80°F	85°F	kBtuh	kW	75°F	80°F	85°F	kBtuh	kW	75°F	80°F	85°F		
63°F	3200	121.9	6.86	0.68	0.81	0.92	117.3	7.78	0.7	0.82	0.93	112.6	8.84	0.71	0.84	0.96	107.4	10.1	0.72	0.86	0.98	
	4000	128.8	6.92	0.74	0.87	0.99	123.6	7.84	0.75	0.88	1	118.8	8.94	0.76	0.9	1	113.1	10.17	0.79	0.93	1	
	4800	133.6	6.98	0.79	0.93	1	128.2	7.89	0.81	0.95	1	122.8	8.99	0.82	0.97	1	117.1	10.23	0.84	1	1	
67°F	3200	128	6.92	0.54	0.66	0.78	122.7	7.83	0.55	0.67	0.8	117.2	8.92	0.56	0.7	0.81	111.4	10.16	0.57	0.7	0.83	
	4000	133.6	6.99	0.58	0.71	0.84	127.7	7.9	0.58	0.73	0.86	121.9	8.98	0.59	0.75	0.88	115.7	10.22	0.6	0.78	0.9	
	4800	137	7.03	0.61	0.78	0.9	131.3	7.94	0.62	0.79	0.92	125.3	9.01	0.63	0.8	0.95	119	10.26	0.64	0.83	0.98	
71°F	3200	134.3	7	0.42	0.54	0.64	129.1	7.92	0.42	0.54	0.66	123.2	9	0.43	0.55	0.67	117.6	10.24	0.43	0.56	0.68	
	4000	140	7.08	0.43	0.57	0.7	134.2	7.98	0.44	0.58	0.71	128.2	9.05	0.44	0.59	0.73	121.6	10.31	0.46	0.6	0.75	
	4800	144	7.14	0.46	0.6	0.74	137.9	8.05	0.46	0.62	0.76	131.7	9.12	0.47	0.62	0.77	124.8	10.35	0.47	0.64	0.79	

RATINGS

NOTE – For Temperatures and Capacities not shown in tables, see bulletin – Cooling Unit Rating Table Correction Factor Data in Miscellaneous Engineering Data section.

12.5 TON - LGX150S5M (1 COMPRESSOR - PART LOAD)

Entering Wet Bulb Temperature	Total Air Volume	Outdoor Air Temperature Entering Outdoor Coil																				
		65°F						75°F					85°F					95°F				
		Total Cool Cap.	Comp. Motor Input	Sensible To Total Ratio (S/T)			Total Cool Cap.	Comp. Motor Input	Sensible To Total Ratio (S/T)			Total Cool Cap.	Comp. Motor Input	Sensible To Total Ratio (S/T)			Total Cool Cap.	Comp. Motor Input	Sensible To Total Ratio (S/T)			
				Dry Bulb					Dry Bulb					Dry Bulb					Dry Bulb			
cfm	kBtuh	kW	75°F	80°F	85°F	kBtuh	kW	75°F	80°F	85°F	kBtuh	kW	75°F	80°F	85°F	kBtuh	kW	75°F	80°F	85°F		
63°F	2640	60.7	2.1	0.81	1	1	58.5	2.38	0.83	1	1	56.4	2.75	0.85	1	1	53.8	3.17	0.87	1	1	
	3300	64.2	2.07	0.88	1	1	61.8	2.37	0.9	1	1	59.2	2.74	0.92	1	1	56.8	3.16	1	1	1	
	3960	66.8	2.04	0.98	1	1	64.4	2.35	1	1	1	61.7	2.73	1	1	1	58.8	3.14	1	1	1	
67°F	2640	63.1	2.08	0.63	0.79	0.98	60.6	2.38	0.65	0.81	1	58.1	2.74	0.66	0.83	1	55.1	3.17	0.68	0.85	1	
	3300	65.6	2.05	0.68	0.86	1	62.9	2.36	0.69	0.88	1	59.9	2.73	0.71	0.91	1	57.1	3.16	0.72	0.93	1	
	3960	67.4	2.04	0.72	0.92	1	64.7	2.35	0.73	1	1	61.7	2.73	0.75	1	1	58.8	3.14	0.77	1	1	
71°F	2640	66.1	2.05	0.47	0.63	0.77	63.4	2.36	0.47	0.64	0.79	60.4	2.73	0.48	0.65	0.81	57.4	3.15	0.49	0.67	0.84	
	3300	68.3	2.02	0.49	0.68	0.84	65.5	2.35	0.5	0.69	0.86	62.6	2.73	0.51	0.7	0.89	59.6	3.14	0.52	0.72	0.92	
	3960	70.1	2	0.51	0.72	0.91	67.4	2.33	0.52	0.73	0.93	64.3	2.72	0.54	0.75	1	61	3.13	0.55	0.77	1	

12.5 TON - LGX150S5M (2 COMPRESSORS - PART LOAD / FULL LOAD)

Entering Wet Bulb Temperature	Total Air Volume	Outdoor Air Temperature Entering Outdoor Coil																			
		85°F					95°F					105°F					115°F				
		Total Cool Cap.	Comp. Motor Input	Sensible To Total Ratio (S/T)			Total Cool Cap.	Comp. Motor Input	Sensible To Total Ratio (S/T)			Total Cool Cap.	Comp. Motor Input	Sensible To Total Ratio (S/T)			Total Cool Cap.	Comp. Motor Input	Sensible To Total Ratio (S/T)		
				Dry Bulb					Dry Bulb					Dry Bulb					Dry Bulb		
cfm	kBtuh	kW	75°F	80°F	85°F	kBtuh	kW	75°F	80°F	85°F	kBtuh	kW	75°F	80°F	85°F	kBtuh	kW	75°F	80°F	85°F	
63°F	3000	127.7	7.91	0.65	0.78	0.89	122.9	9.04	0.66	0.81	0.91	116.9	10.31	0.68	0.82	0.93	110.4	11.72	0.69	0.86	0.95
	3750	134.9	7.91	0.7	0.86	0.96	129.9	9.05	0.71	0.86	0.98	124.2	10.33	0.73	0.88	1	117.7	11.74	0.76	0.9	1
	4500	141	7.9	0.75	0.9	1	135.5	9.06	0.77	0.92	1	129.4	10.33	0.79	0.94	1	122.7	11.74	0.81	0.97	1
67°F	3000	135.3	7.89	0.53	0.63	0.74	130.1	9.04	0.53	0.65	0.77	124	10.31	0.54	0.65	0.78	116.5	11.72	0.55	0.67	0.82
	3750	141.8	7.9	0.55	0.67	0.82	136.2	9.03	0.56	0.69	0.83	129.3	10.32	0.57	0.7	0.86	121.9	11.73	0.58	0.72	0.88
	4500	146.1	7.88	0.58	0.72	0.87	139.9	9.05	0.59	0.73	0.89	133.1	10.32	0.59	0.76	0.91	125.3	11.74	0.6	0.79	0.94
71°F	3000	143.3	7.88	0.4	0.51	0.6	137.4	9.05	0.41	0.52	0.62	131.1	10.3	0.41	0.53	0.63	123.7	11.72	0.42	0.54	0.64
	3750	149.9	7.88	0.42	0.54	0.65	143.8	9.04	0.42	0.55	0.67	136.7	10.32	0.43	0.55	0.68	129.1	11.72	0.43	0.57	0.69
	4500	154.6	7.87	0.43	0.57	0.7	147.8	9.05	0.43	0.58	0.71	140.3	10.31	0.45	0.58	0.74	132.4	11.73	0.45	0.59	0.77

12.5 TON - LGX150S5M (2 COMPRESSORS - FULL LOAD)

Entering Wet Bulb Temperature	Total Air Volume	Outdoor Air Temperature Entering Outdoor Coil																				
		85°F						95°F					105°F					115°F				
		Total Cool Cap.	Comp. Motor Input	Sensible To Total Ratio (S/T)			Total Cool Cap.	Comp. Motor Input	Sensible To Total Ratio (S/T)			Total Cool Cap.	Comp. Motor Input	Sensible To Total Ratio (S/T)			Total Cool Cap.	Comp. Motor Input	Sensible To Total Ratio (S/T)			
				Dry Bulb					Dry Bulb					Dry Bulb					Dry Bulb			
cfm	kBtuh	kW	75°F	80°F	85°F	kBtuh	kW	75°F	80°F	85°F	kBtuh	kW	75°F	80°F	85°F	kBtuh	kW	75°F	80°F	85°F		
63°F	4000	144.9	8.98	0.69	0.81	0.92	139.1	10.18	0.7	0.82	0.94	133.3	11.61	0.71	0.84	0.96	127.2	13.17	0.73	0.86	0.99	
	5000	152.2	8.98	0.73	0.87	1	146.3	10.22	0.74	0.89	1	140.5	11.61	0.77	0.91	1	133.1	13.2	0.79	0.94	1	
	6000	158.4	9.02	0.78	0.93	1	152.1	10.24	0.8	0.95	1	146	11.64	0.82	0.98	1	138.2	13.2	0.85	1	1	
67°F	4000	151.9	8.97	0.55	0.67	0.78	145.1	10.2	0.55	0.67	0.8	138.7	11.58	0.56	0.68	0.81	131.8	13.17	0.58	0.7	0.84	
	5000	157.7	9.02	0.58	0.71	0.84	151.1	10.25	0.58	0.73	0.86	144.1	11.62	0.6	0.75	0.88	136.1	13.19	0.61	0.78	0.91	
	6000	162.5	9.06	0.61	0.77	0.91	155.4	10.29	0.62	0.8	0.93	147.9	11.64	0.63	0.8	0.95	140.5	13.17	0.64	0.83	0.99	
71°F	4000	160	9.03	0.42	0.53	0.64	153.5	10.24	0.42	0.54	0.66	146.6	11.63	0.43	0.55	0.66	138.8	13.19	0.42	0.56	0.68	
	5000	166.1	9.06	0.43	0.57	0.69	159.2	10.32	0.44	0.57	0.71	151.7	11.68	0.44	0.59	0.72	143.1	13.19	0.43	0.59	0.74	
	6000	170.5	9.1	0.44	0.59	0.74	163.5	10.35	0.44	0.6	0.77	154.8	11.71	0.45	0.62	0.78	146.3	13.22	0.46	0.63	0.8	

DEHUMIDIFICATION SYSTEM RATINGS

NOTE - For Temperatures and Capacities not shown in tables, see bulletin - Cooling Unit Rating Table Correction Factor Data in Miscellaneous Engineering Data section.

7.5 TON - LGX092S5 DEHUMIDIFICATION OPERATING (PART LOAD)

Entering Wet Bulb Temperature	Total Air Volume	Outdoor Air Temperature Entering Outdoor Coil																				
		65°F						75°F					85°F					95°F				
		Total Cool Cap.	Comp. Motor Input	Sensible To Total Ratio (S/T)			Total Cool Cap.	Comp. Motor Input	Sensible To Total Ratio (S/T)			Total Cool Cap.	Comp. Motor Input	Sensible To Total Ratio (S/T)			Total Cool Cap.	Comp. Motor Input	Sensible To Total Ratio (S/T)			
				Dry Bulb					Dry Bulb					Dry Bulb					Dry Bulb			
		cfm	kBtuh	kW	75°F	80°F	85°F	kBtuh	kW	75°F	80°F	85°F	kBtuh	kW	75°F	80°F	85°F	kBtuh	kW	75°F	80°F	85°F
63°F	1800	38.7	2.70	0.56	0.78	0.98	29.1	2.93	0.49	0.78	1.00	19.5	3.21	0.31	0.76	1.00	9.8	3.57	-0.18	0.76	1.00	
	2150	41.2	2.75	0.63	0.86	1.00	31.2	2.97	0.56	0.88	1.00	20.9	3.25	0.43	0.92	1.00	10.9	3.61	0.00	1.00	1.00	
	2500	43.1	2.80	0.68	0.94	1.00	32.6	3.01	0.64	0.97	1.00	21.9	3.29	0.55	1.00	1.00	11.6	3.65	0.25	1.00	1.00	
67°F	1800	43.8	2.76	0.37	0.57	0.75	34.3	2.98	0.25	0.51	0.75	24.7	3.26	0.03	0.40	0.72	15.3	3.62	-0.53	0.17	0.69	
	2150	46.2	2.81	0.41	0.62	0.82	36.1	3.03	0.30	0.58	0.83	26.0	3.31	0.09	0.50	0.84	16.2	3.66	-0.39	0.32	0.88	
	2500	48.1	2.86	0.45	0.68	0.89	37.7	3.07	0.34	0.64	0.92	27.0	3.35	0.15	0.58	0.96	16.2	3.69	-0.33	0.44	1.00	
71°F	1800	48.8	2.83	0.21	0.39	0.56	39.4	3.04	0.09	0.30	0.51	29.9	3.32	-0.18	0.15	0.44	20.5	3.68	-0.67	-0.11	0.30	
	2150	51.3	2.89	0.23	0.43	0.62	41.3	3.10	0.09	0.35	0.58	31.1	3.37	-0.16	0.22	0.53	20.9	3.72	-0.58	-0.04	0.42	
	2500	53.2	2.93	0.24	0.47	0.67	42.6	3.13	0.11	0.40	0.64	31.9	3.40	-0.12	0.27	0.60	21.1	3.74	-0.62	0.02	0.53	

7.5 TON - LGX092S5 DEHUMIDIFICATION OPERATING (FULL LOAD)

Entering Wet Bulb Temperature	Total Air Volume	Outdoor Air Temperature Entering Outdoor Coil																				
		65°F						75°F					85°F					95°F				
		Total Cool Cap.	Comp. Motor Input	Sensible To Total Ratio (S/T)			Total Cool Cap.	Comp. Motor Input	Sensible To Total Ratio (S/T)			Total Cool Cap.	Comp. Motor Input	Sensible To Total Ratio (S/T)			Total Cool Cap.	Comp. Motor Input	Sensible To Total Ratio (S/T)			
				Dry Bulb					Dry Bulb					Dry Bulb					Dry Bulb			
		cfm	kBtuh	kW	75°F	80°F	85°F	kBtuh	kW	75°F	80°F	85°F	kBtuh	kW	75°F	80°F	85°F	kBtuh	kW	75°F	80°F	85°F
63°F	2000	67.6	3.96	0.55	0.70	0.81	56.9	4.42	0.50	0.68	0.82	46.0	4.96	0.44	0.67	0.83	35.6	5.61	0.35	0.64	0.86	
	2450	72.7	4.00	0.59	0.74	0.87	61.3	4.46	0.57	0.74	0.89	49.5	5.00	0.52	0.74	0.91	38.6	5.64	0.44	0.72	0.96	
	2900	76.5	4.05	0.63	0.79	0.93	64.3	4.50	0.61	0.79	0.95	52.1	5.05	0.57	0.79	0.99	40.3	5.68	0.50	0.80	1.00	
67°F	2000	75.5	4.00	0.40	0.54	0.66	64.2	4.45	0.34	0.50	0.66	53.5	5.00	0.26	0.46	0.64	42.3	5.64	0.15	0.39	0.62	
	2450	79.4	4.05	0.43	0.58	0.73	67.7	4.51	0.38	0.55	0.72	55.7	5.04	0.30	0.52	0.71	44.1	5.67	0.18	0.46	0.70	
	2900	82.5	4.09	0.44	0.62	0.75	69.9	4.54	0.39	0.61	0.77	57.2	5.08	0.33	0.57	0.77	45.2	5.72	0.20	0.52	0.76	
71°F	2000	82.9	4.06	0.28	0.39	0.52	72.2	4.52	0.21	0.35	0.50	61.0	5.06	0.12	0.29	0.46	50.1	5.69	-0.01	0.21	0.40	
	2450	81.8	4.38	0.29	0.40	0.55	75.6	4.56	0.21	0.39	0.54	63.7	5.11	0.12	0.33	0.51	51.9	5.74	-0.01	0.25	0.46	
	2900	84.9	4.43	0.24	0.42	0.58	78.0	4.60	0.23	0.41	0.56	65.3	5.14	0.13	0.36	0.57	53.0	5.78	-0.03	0.28	0.53	

8.5 TON - LGX102S5 DEHUMIDIFICATION OPERATING (PART LOAD)

Entering Wet Bulb Temperature	Total Air Volume	Outdoor Air Temperature Entering Outdoor Coil																				
		65°F						75°F					85°F					95°F				
		Total Cool Cap.	Comp. Motor Input	Sensible To Total Ratio (S/T)			Total Cool Cap.	Comp. Motor Input	Sensible To Total Ratio (S/T)			Total Cool Cap.	Comp. Motor Input	Sensible To Total Ratio (S/T)			Total Cool Cap.	Comp. Motor Input	Sensible To Total Ratio (S/T)			
				Dry Bulb					Dry Bulb					Dry Bulb					Dry Bulb			
		cfm	kBtuh	kW	75°F	80°F	85°F	kBtuh	kW	75°F	80°F	85°F	kBtuh	kW	75°F	80°F	85°F	kBtuh	kW	75°F	80°F	85°F
63°F	1800	42.0	2.67	0.53	0.73	0.92	34.2	2.76	0.47	0.73	0.95	26.3	2.92	0.37	0.70	0.97	18.5	3.17	0.19	0.68	0.97	
	2400	45.0	2.78	0.63	0.88	0.96	36.3	2.88	0.59	0.89	0.96	27.4	3.04	0.52	0.92	0.97	13.7	3.58	0.39	1.00	0.97	
	3000	48.0	2.89	0.73	0.96	0.96	38.8	2.99	0.71	0.97	0.97	29.5	3.16	0.69	0.98	0.97	14.5	3.75	0.63	1.00	1.00	
67°F	1800	46.9	2.78	0.34	0.53	0.71	39.2	2.87	0.25	0.48	0.70	31.3	3.04	0.11	0.41	0.68	18.6	3.56	-0.12	0.16	0.66	
	2400	50.4	2.90	0.40	0.63	0.84	41.5	2.99	0.32	0.60	0.86	32.5	3.15	0.19	0.55	0.87	17.8	3.73	-0.04	0.35	0.91	
	3000	52.5	2.98	0.46	0.72	0.95	42.9	3.08	0.39	0.71	0.97	32.7	3.23	0.27	0.69	0.98	17.0	3.83	0.05	0.59	1.00	
71°F	1800	51.7	2.89	0.18	0.35	0.52	43.9	2.99	0.08	0.29	0.49	35.9	3.15	-0.08	0.19	0.43	22.7	3.72	-0.33	-0.15	0.35	
	2400	55.3	3.02	0.20	0.42	0.62	46.6	3.11	0.10	0.36	0.60	37.4	3.27	-0.06	0.27	0.56	22.5	3.88	-0.31	-0.07	0.44	
	3000	57.9	3.10	0.24	0.48	0.71	48.3	3.19	0.13	0.43	0.70	38.0	3.35	-0.04	0.35	0.66	21.9	3.98	-0.31	0.02	0.63	

8.5 TON - LGX102S5 DEHUMIDIFICATION OPERATING (FULL LOAD)

Entering Wet Bulb Temperature	Total Air Volume	Outdoor Air Temperature Entering Outdoor Coil																				
		65°F						75°F					85°F					95°F				
		Total Cool Cap.	Comp. Motor Input	Sensible To Total Ratio (S/T)			Total Cool Cap.	Comp. Motor Input	Sensible To Total Ratio (S/T)			Total Cool Cap.	Comp. Motor Input	Sensible To Total Ratio (S/T)			Total Cool Cap.	Comp. Motor Input	Sensible To Total Ratio (S/T)			
				Dry Bulb					Dry Bulb					Dry Bulb					Dry Bulb			
		cfm	kBtuh	kW	75°F	80°F	85°F	kBtuh	kW	75°F	80°F	85°F	kBtuh	kW	75°F	80°F	85°F	kBtuh	kW	75°F	80°F	85°F
63°F	2400	82.9	4.74	0.55	0.69	0.81	70.5	5.30	0.52	0.70	0.83	55.9	6.30	0.48	0.70	0.86	44.9	6.70	0.42	0.68	0.89	
	2900	87.3	4.80	0.59	0.74	0.87	74.4	5.36	0.56	0.75	0.89	60.9	6.00	0.52	0.75	0.93	47.4	6.75	0.47	0.76	0.98	
	3400	91.1	4.88	0.63	0.79	0.93	77.4	5.40	0.61	0.80	0.95	62.9	6.04	0.57	0.82	0.99	49.9	6.78	0.56	0.83	1.00	
67°F	2400	91.9	4.81	0.40	0.54	0.66	79.4	5.36	0.36	0.51	0.66	66.6	6.00	0.30	0.48	0.66	54.4	6.74	0.21	0.43	0.64	
	2900	96.1	4.90	0.42	0.57	0.72	82.8	5.44	0.37	0.56	0.72	69.3	6.06	0.33	0.53	0.72	55.4	6.81	0.23	0.50	0.72	
	3400	100.1	4.94	0.45	0.60	0.76	85.9	5.48	0.40	0.60	0.77	71.0	6.09	0.33	0.58	0.78	57.0	6.84	0.26	0.56	0.79	
71°F	2400	100.3	4.91	0.28	0.40	0.53	87.9	5.45	0.22	0.36	0.49	75.2	6.07	0.14	0.31	0.46	62.3	6.82	0.04	0.25	0.43	
	2900	105.7	4.98	0.29	0.43	0.56	92.0	5.51	0.23	0.40	0.54	78.7	6.48	0.14	0.35	0.52	65.1	6.87	0.03	0.28	0.49	
	3400	109.2	5.03	0.30	0.45	0.59	94.7	5.56	0.25	0.42	0.59	81.0	6.54	0.16	0.36	0.58	66.4	6.92	0.03	0.29	0.55	

DEHUMIDIFICATION SYSTEM RATINGS

NOTE - For Temperatures and Capacities not shown in tables, see bulletin - Cooling Unit Rating Table Correction Factor Data in Miscellaneous Engineering Data section.

10 TON - LGX120S5 DEHUMIDIFICATION OPERATING (PART LOAD)

Entering Wet Bulb Temperature	Total Air Volume	Outdoor Air Temperature Entering Outdoor Coil																				
		65°F						75°F					85°F					95°F				
		Total Cool Cap.	Comp. Motor Input	Sensible To Total Ratio (S/T)			Total Cool Cap.	Comp. Motor Input	Sensible To Total Ratio (S/T)			Total Cool Cap.	Comp. Motor Input	Sensible To Total Ratio (S/T)			Total Cool Cap.	Comp. Motor Input	Sensible To Total Ratio (S/T)			
				Dry Bulb					Dry Bulb					Dry Bulb					Dry Bulb			
cfm	kBtuh	kW	75°F	80°F	85°F	kBtuh	kW	75°F	80°F	85°F	kBtuh	kW	75°F	80°F	85°F	kBtuh	kW	75°F	80°F	85°F		
63°F	2000	42.2	2.83	0.57	0.75	0.78	39.8	2.80	0.53	0.74	0.77	31.2	2.97	0.47	0.72	0.74	15.1	3.51	0.36	0.63	0.71	
	2600	45.0	2.89	0.66	0.78	0.79	42.9	2.85	0.64	0.76	0.78	33.6	3.02	0.61	0.73	0.75	15.9	3.61	0.54	0.64	0.72	
	3200	46.8	2.94	0.75	0.79	0.80	45.0	2.88	0.73	0.77	0.79	35.1	3.05	0.70	0.74	0.76	16.2	3.67	0.60	0.64	0.72	
67°F	2000	46.4	2.89	0.40	0.55	0.74	43.9	2.84	0.34	0.55	0.74	35.0	3.01	0.24	0.51	0.74	17.6	3.56	0.06	0.33	0.72	
	2600	47.3	2.93	0.46	0.64	0.80	45.0	2.87	0.40	0.65	0.79	35.2	3.03	0.30	0.63	0.77	16.6	3.62	0.12	0.55	0.73	
	3200	47.7	2.95	0.51	0.73	0.81	45.5	2.88	0.45	0.75	0.80	35.2	3.05	0.36	0.74	0.77	16.3	3.67	0.19	0.67	0.74	
71°F	2000	50.5	2.94	0.26	0.38	0.58	48.7	2.89	0.18	0.38	0.56	39.7	3.05	0.05	0.30	0.49	21.8	3.65	-0.15	-0.01	0.48	
	2600	51.7	2.97	0.29	0.43	0.67	49.9	2.90	0.20	0.44	0.66	40.0	3.08	0.07	0.37	0.62	20.8	3.69	-0.17	0.07	0.63	
	3200	52.1	3.00	0.30	0.49	0.74	50.2	2.93	0.22	0.50	0.75	39.8	3.10	0.08	0.43	0.75	19.9	3.73	-0.17	0.16	0.74	

10 TON - LGX120S5 DEHUMIDIFICATION OPERATING (FULL LOAD)

Entering Wet Bulb Temperature	Total Air Volume	Outdoor Air Temperature Entering Outdoor Coil																				
		65°F						75°F					85°F					95°F				
		Total Cool Cap.	Comp. Motor Input	Sensible To Total Ratio (S/T)			Total Cool Cap.	Comp. Motor Input	Sensible To Total Ratio (S/T)			Total Cool Cap.	Comp. Motor Input	Sensible To Total Ratio (S/T)			Total Cool Cap.	Comp. Motor Input	Sensible To Total Ratio (S/T)			
				Dry Bulb					Dry Bulb					Dry Bulb					Dry Bulb			
cfm	kBtuh	kW	75°F	80°F	85°F	kBtuh	kW	75°F	80°F	85°F	kBtuh	kW	75°F	80°F	85°F	kBtuh	kW	75°F	80°F	85°F		
63°F	2400	96.6	5.09	0.51	0.65	0.77	85.6	5.71	0.50	0.64	0.78	74.3	6.14	0.47	0.64	0.78	63.1	6.81	0.42	0.62	0.78	
	3000	103.1	5.30	0.56	0.72	0.83	86.5	5.86	0.55	0.72	0.84	79.5	6.46	0.53	0.73	0.85	67.6	7.13	0.49	0.70	0.87	
	3600	103.2	5.34	0.60	0.76	0.88	91.1	6.10	0.59	0.76	0.90	78.0	6.59	0.56	0.77	0.92	65.6	7.31	0.53	0.77	0.96	
67°F	2400	100.0	5.18	0.38	0.50	0.62	94.7	6.00	0.33	0.50	0.61	83.2	6.47	0.31	0.47	0.60	65.9	7.08	0.21	0.40	0.58	
	3000	105.9	5.39	0.40	0.54	0.68	95.5	6.18	0.36	0.52	0.68	82.5	6.67	0.31	0.51	0.68	70.3	7.39	0.25	0.48	0.68	
	3600	118.0	5.68	0.42	0.61	0.75	99.5	6.38	0.39	0.58	0.74	86.1	6.88	0.34	0.56	0.75	72.9	7.60	0.30	0.54	0.75	
71°F	2400	115.1	5.56	0.24	0.40	0.50	98.5	6.20	0.19	0.34	0.46	87.0	6.71	0.14	0.29	0.44	74.8	7.42	0.06	0.24	0.40	
	3000	121.7	5.76	0.29	0.43	0.54	103.9	6.46	0.22	0.36	0.51	92.0	6.99	0.15	0.34	0.50	79.3	7.71	0.07	0.27	0.47	
	3600	126.9	5.90	0.30	0.45	0.59	108.6	6.66	0.22	0.40	0.56	95.7	7.20	0.17	0.37	0.55	83.2	7.91	0.09	0.33	0.54	

12.5 TON - LGX150S5 DEHUMIDIFICATION OPERATING (PART LOAD)

Entering Wet Bulb Temperature	Total Air Volume	Outdoor Air Temperature Entering Outdoor Coil																				
		65°F						75°F					85°F					95°F				
		Total Cool Cap.	Comp. Motor Input	Sensible To Total Ratio (S/T)			Total Cool Cap.	Comp. Motor Input	Sensible To Total Ratio (S/T)			Total Cool Cap.	Comp. Motor Input	Sensible To Total Ratio (S/T)			Total Cool Cap.	Comp. Motor Input	Sensible To Total Ratio (S/T)			
				Dry Bulb					Dry Bulb					Dry Bulb					Dry Bulb			
cfm	kBtuh	kW	75°F	80°F	85°F	kBtuh	kW	75°F	80°F	85°F	kBtuh	kW	75°F	80°F	85°F	kBtuh	kW	75°F	80°F	85°F		
63°F	2500	53.7	3.03	0.57	0.78	0.93	41.7	3.32	0.49	0.76	0.93	29.8	3.66	0.15	0.73	0.91	12.8	4.39	0.00	0.57	0.86	
	3200	57.2	3.12	0.66	0.89	0.94	44.7	3.38	0.61	0.90	0.94	32.1	3.73	0.39	0.91	0.93	20.3	4.14	0.29	0.89	0.89	
	3900	61.1	3.16	0.74	0.95	0.95	48.2	3.45	0.72	0.94	0.94	35.0	3.79	0.61	0.93	0.94	22.4	4.21	0.54	0.91	0.91	
67°F	2500	58.2	3.11	0.38	0.57	0.75	47.7	3.39	0.28	0.52	0.74	35.9	3.73	-0.15	0.42	0.72	23.9	4.13	-0.28	0.24	0.64	
	3200	63.3	3.17	0.44	0.66	0.86	50.4	3.46	0.34	0.62	0.88	37.4	3.79	-0.03	0.56	0.89	24.7	4.20	-0.16	0.44	0.91	
	3900	66.2	3.20	0.50	0.74	0.95	52.6	3.50	0.41	0.72	0.95	38.3	3.83	0.26	0.70	0.95	25.3	4.24	-0.39	0.64	0.94	
71°F	2500	66.0	3.18	0.22	0.41	0.58	54.1	3.47	0.09	0.32	0.53	41.9	3.80	-0.11	0.19	0.46	30.2	4.21	-0.47	-0.03	0.19	
	3200	69.6	3.22	0.26	0.47	0.66	57.1	3.52	0.13	0.40	0.64	43.7	3.86	-0.07	0.28	0.59	31.2	4.27	-0.76	0.08	0.42	
	3900	72.5	3.26	0.29	0.53	0.74	58.6	3.56	0.17	0.47	0.73	44.8	3.90	-0.04	0.36	0.71	25.9	4.63	-0.94	0.01	0.68	

12.5 TON - LGX150S5 DEHUMIDIFICATION OPERATING (FULL LOAD)

Entering Wet Bulb Temperature	Total Air Volume	Outdoor Air Temperature Entering Outdoor Coil																				
		65°F						75°F					85°F					95°F				
		Total Cool Cap.	Comp. Motor Input	Sensible To Total Ratio (S/T)			Total Cool Cap.	Comp. Motor Input	Sensible To Total Ratio (S/T)			Total Cool Cap.	Comp. Motor Input	Sensible To Total Ratio (S/T)			Total Cool Cap.	Comp. Motor Input	Sensible To Total Ratio (S/T)			
				Dry Bulb					Dry Bulb					Dry Bulb					Dry Bulb			
cfm	kBtuh	kW	75°F	80°F	85°F	kBtuh	kW	75°F	80°F	85°F	kBtuh	kW	75°F	80°F	85°F	kBtuh	kW	75°F	80°F	85°F		
63°F	2900	123.8	6.61	0.55	0.67	0.78	102.0	7.24	0.52	0.67	0.79	93.5	7.86	0.51	0.67	0.80	78.5	8.73	0.47	0.65	0.81	
	3650	132.1	6.72	0.59	0.74	0.83	115.5	7.32	0.58	0.74	0.86	99.8	8.05	0.55	0.73	0.86	84.6	9.60	0.52	0.73	0.89	
	4400	137.6	6.82	0.62	0.77	0.88	120.5	7.46	0.63	0.78	0.90	103.5	8.19	0.61	0.79	0.93	87.3	9.78	0.58	0.79	0.96	
67°F	2900	135.7	6.73	0.42	0.54	0.65	120.4	7.33	0.40	0.52	0.64	105.1	8.06	0.35	0.50	0.63	90.2	8.93	0.29	0.47	0.63	
	3650	143.5	6.85	0.45	0.58	0.69	127.6	7.50	0.42	0.57	0.71	104.5	8.33	0.37	0.54	0.71	94.6	9.79	0.33	0.53	0.71	
	4400	148.5	6.96	0.46	0.62	0.75	130.9	7.61	0.44	0.61	0.76	114.7	9.01	0.41	0.58	0.77	97.7	9.98	0.33	0.59	0.77	
71°F	2900	138.8	6.93	0.29	0.40	0.52	133.0	7.51	0.27	0.39	0.51	117.3	8.25	0.22	0.35	0.48	102.8	9.85	0.15	0.31	0.46	
	3650	156.5	7.00	0.31	0.44	0.57	140.1	7.66	0.28	0.41	0.55	124.9	9.09	0.23	0.39	0.53	108.7	10.08	0.14	0.34	0.52	
	4400	160.0	7.10	0.32	0.47	0.59	145.5	8.41	0.27	0.43	0.59	128.0	9.25	0.22	0.41	0.58	104.1	10.38	0.12	0.36	0.58	

LGX092S5M AND LGX102S5M - BASE UNIT

BLOWER TABLE INCLUDES RESISTANCE FOR BASE UNIT ONLY (NO HEAT SECTION) WITH DRY INDOOR COIL AND AIR FILTERS IN PLACE. FOR ALL UNITS ADD:

- 1 – Wet indoor coil air resistance of selected unit.
- 2 – Any factory installed options air resistance (heat section, economizer, etc.)
- 3 – Any field installed accessories air resistance (duct resistance, diffuser, etc.)

Then determine from blower table blower motor output required.

See page 31 for blower motors and drives.

See page 31 for wet coil and option/accessory air resistance data.

Maximum Static Pressure With Gas Heat - 2.0 in. w.g.

Minimum Air Volume Required For Different Gas Heat Sizes:

Standard - 2150 cfm; Medium - 2250 cfm; High - 2600 cfm

Total Air Volume cfm	Total Static Pressure – in. w.g.																										
	0.2		0.4		0.6		0.8		1.0		1.2		1.4		1.6		1.8		2		2.2		2.4		2.6		
	RPM	BHP	RPM	BHP	RPM	BHP	RPM	BHP	RPM	BHP	RPM	BHP	RPM	BHP	RPM	BHP	RPM	BHP	RPM	BHP	RPM	BHP	RPM	BHP	RPM	BHP	RPM
2000	593	0.11	636	0.07	682	0.10	731	0.22	784	0.60	840	0.96	898	1.26	948	1.38	996	1.47	1045	1.57	1092	1.71	1140	1.92	1188	2.32	
2250	604	0.15	645	0.11	690	0.15	739	0.39	790	0.74	846	1.08	901	1.34	953	1.48	1002	1.57	1052	1.70	1100	1.86	1149	2.09	1197	2.42	
2500	615	0.19	655	0.15	699	0.20	747	0.55	797	0.89	851	1.20	906	1.44	959	1.58	1009	1.68	1059	1.83	1108	2.01	1158	2.26	1206	2.52	
2750	626	0.23	666	0.19	709	0.37	755	0.71	805	1.03	858	1.32	912	1.55	966	1.70	1017	1.81	1067	1.97	1117	2.17	1166	2.44	1215	2.71	
3000	637	0.27	677	0.24	719	0.55	764	0.87	813	1.18	866	1.45	920	1.67	975	1.82	1026	1.96	1076	2.13	1126	2.35	1176	2.63	1225	2.92	
3250	650	0.31	688	0.43	730	0.73	775	1.04	823	1.34	875	1.60	930	1.81	985	1.97	1036	2.12	1086	2.31	1136	2.54	1186	2.83	1235	3.13	
3500	663	0.35	700	0.63	741	0.92	786	1.22	834	1.50	886	1.76	942	1.96	997	2.14	1048	2.31	1097	2.51	1147	2.75	1196	3.04	1245	3.35	
3750	676	0.57	714	0.84	754	1.12	798	1.41	846	1.68	899	1.93	956	2.14	1010	2.32	1060	2.51	1109	2.72	1158	2.98	1207	3.27	1255	3.58	
4000	691	0.79	728	1.05	768	1.33	812	1.61	860	1.88	914	2.12	971	2.34	1023	2.53	1072	2.73	1121	2.95	1169	3.22	1218	3.51	1266	3.83	
4250	706	1.03	743	1.28	783	1.55	827	1.82	876	2.09	931	2.33	987	2.55	1037	2.76	1085	2.97	1133	3.20	1181	3.47	1229	3.76	1277	4.08	
4500	722	1.27	759	1.52	799	1.78	844	2.05	894	2.31	949	2.56	1003	2.79	1052	3.00	1098	3.22	1145	3.46	1193	3.73	1241	4.03	1289	4.34	
4750	739	1.53	776	1.77	817	2.03	862	2.30	913	2.56	968	2.81	1020	3.04	1066	3.27	1112	3.49	1158	3.74	1205	4.01	1253	4.30	1301	4.61	
5000	757	1.79	794	2.04	835	2.30	882	2.56	934	2.83	988	3.08	1036	3.32	1081	3.55	1125	3.78	1171	4.02	1218	4.29	1265	4.59	1312	4.89	

BLOWER DATA

BELT DRIVE - 10 | 12.5 TON

LGX120S5M AND LGX150S5M - BASE UNIT

BLOWER TABLE INCLUDES RESISTANCE FOR BASE UNIT ONLY (NO HEAT SECTION) WITH DRY INDOOR COIL AND AIR FILTERS IN PLACE. FOR ALL UNITS ADD:

- 1 – Wet indoor coil air resistance of selected unit.
- 2 – Any factory installed options air resistance (heat section, economizer, etc.)
- 3 – Any field installed accessories air resistance (duct resistance, diffuser, etc.)

Then determine from blower table blower motor output required.

See page 31 for blower motors and drives.

See page 31 for wet coil and option/accessory air resistance data.

Maximum Static Pressure With Gas Heat - 2.0 in. w.g.

Minimum Air Volume Required For Different Gas Heat Sizes:

Standard - 2150 cfm; Medium - 2250 cfm; High - 2600 cfm

Total Air Volume cfm	Total Static Pressure – in. w.g.																										
	0.2		0.4		0.6		0.8		1.0		1.2		1.4		1.6		1.8		2.0		2.2		2.4		2.6		
	RPM	BHP	RPM	BHP	RPM	BHP	RPM	BHP	RPM	BHP	RPM	BHP	RPM	BHP	RPM	BHP	RPM	BHP	RPM	BHP	RPM	BHP	RPM	BHP	RPM	BHP	RPM
2000	497	0.25	558	0.44	624	0.6	694	0.74	764	0.85	830	0.99	889	1.16	943	1.34	994	1.52	1045	1.71	1096	1.89	1146	2.08	1197	2.27	
2250	511	0.34	573	0.52	638	0.68	708	0.82	776	0.94	839	1.09	896	1.26	948	1.45	998	1.64	1048	1.83	1098	2.01	1149	2.2	1200	2.4	
2500	527	0.44	589	0.62	654	0.78	723	0.91	789	1.05	850	1.21	904	1.39	955	1.58	1003	1.77	1052	1.96	1101	2.14	1152	2.33	1203	2.53	
2750	545	0.55	606	0.72	672	0.88	740	1.03	804	1.17	861	1.34	914	1.53	962	1.72	1010	1.92	1057	2.10	1105	2.29	1154	2.47	1206	2.68	
3000	564	0.66	626	0.84	692	1.01	759	1.16	819	1.32	874	1.49	924	1.68	971	1.88	1017	2.08	1063	2.26	1110	2.44	1158	2.63	1208	2.83	
3250	585	0.79	648	0.98	714	1.14	778	1.31	836	1.48	887	1.66	935	1.86	981	2.06	1026	2.26	1071	2.45	1117	2.63	1163	2.80	1213	3.00	
3500	607	0.93	672	1.13	737	1.31	798	1.48	852	1.66	901	1.85	948	2.05	993	2.26	1037	2.46	1081	2.65	1125	2.83	1171	3.01	1221	3.21	
3750	632	1.10	698	1.31	762	1.50	819	1.67	869	1.86	915	2.05	961	2.25	1005	2.47	1049	2.68	1092	2.88	1136	3.05	1181	3.24	1231	3.45	
4000	660	1.30	726	1.52	787	1.70	838	1.87	885	2.06	930	2.26	974	2.48	1018	2.71	1062	2.93	1105	3.12	1149	3.30	1194	3.49	1245	3.72	
4250	691	1.53	755	1.75	810	1.91	857	2.07	901	2.27	945	2.50	990	2.74	1034	2.98	1077	3.20	1120	3.39	1163	3.58	1210	3.79	1262	4.03	
4500	724	1.78	783	1.98	831	2.12	874	2.28	917	2.50	962	2.75	1006	3.02	1051	3.27	1094	3.49	1137	3.70	1181	3.89	1228	4.11	1281	4.38	
4750	757	2.05	809	2.20	851	2.33	891	2.51	935	2.76	980	3.05	1025	3.33	1070	3.59	1113	3.82	1156	4.03	1201	4.24	1249	4.47	1303	4.75	
5000	787	2.31	831	2.43	870	2.57	910	2.78	954	3.06	1000	3.38	1046	3.68	1091	3.95	1135	4.19	1178	4.40	1224	4.62	1272	4.86	1325	5.13	
5250	814	2.55	852	2.66	889	2.83	930	3.09	975	3.41	1023	3.76	1070	4.08	1115	4.35	1159	4.59	1203	4.81	1248	5.03	1297	5.27	---	---	
5500	835	2.78	871	2.91	909	3.13	952	3.44	999	3.81	1049	4.18	1096	4.51	1142	4.79	1186	5.03	1229	5.24	1275	5.46	1324	5.69	---	---	
5750	854	3.01	890	3.19	930	3.48	977	3.86	1027	4.27	1078	4.66	1126	4.99	1171	5.26	1214	5.49	1258	5.70	---	---	---	---	---	---	
6000	871	3.26	910	3.53	955	3.90	1006	4.34	1060	4.80	1111	5.19	1158	5.51	---	---	---	---	---	---	---	---	---	---	---	---	
6250	890	3.57	934	3.94	985	4.41	1041	4.91	1096	5.38	---	---	---	---	---	---	---	---	---	---	---	---	---	---	---	---	

BLOWER DATA

FACTORY INSTALLED BELT DRIVE KIT SPECIFICATIONS

Nominal HP	Maximum HP	Drive Kit Number	RPM Range
2	2.3	1	590 - 890
2	2.3	2	800 - 1105
2	2.3	3	795 - 1195
3	3.45	4	730 - 970
3	3.45	5	940 - 1200
3	3.45	6	1015 - 1300
5	5.75	10	900 - 1135
5	5.75	11	1050 - 1335

NOTE - Using total air volume and system static pressure requirements determine from blower performance tables rpm and motor output required. Maximum usable output of motors furnished are shown. In Canada, nominal motor output is also maximum usable motor output. If motors of comparable output are used, be sure to keep within the service factor limitations outlined on the motor nameplate.

NOTE – Motor service factor limit - 1.0.

POWER EXHAUST FAN PERFORMANCE

Return Air System Static Pressure	Air Volume Exhausted
in. w.g.	cfm
0	3175
0.05	2955
0.10	2685
0.15	2410
0.20	2165
0.25	1920
0.30	1420
0.35	1200

FACTORY INSTALLED OPTIONS/FIELD INSTALLED ACCESSORY AIR RESISTANCE - in. w.g.

Air Volume cfm	Wet Indoor Coil		Gas Heat Exchanger			Economizer	Reheat Coil	Filters	
	092, 102	120, 150	Standard Heat	Medium Heat	High Heat			MERV 8	MERV 13
1750	0.04	0.04	0.06	0.02	0.02	0.05	0.02	0.01	0.03
2000	0.05	0.05	0.07	0.05	0.06	0.06	0.02	0.01	0.03
2250	0.06	0.06	0.07	0.07	0.08	0.08	0.02	0.01	0.04
2500	0.07	0.07	0.09	0.10	0.11	0.11	0.03	0.01	0.05
2750	0.08	0.08	0.09	0.11	0.12	0.12	0.03	0.02	0.05
3000	0.10	0.09	0.11	0.12	0.13	0.13	0.03	0.02	0.06
3250	0.11	0.10	0.12	0.15	0.16	0.15	0.04	0.02	0.06
3500	0.12	0.11	0.12	0.16	0.17	0.15	0.04	0.03	0.07
3750	0.14	0.13	0.14	0.19	0.20	0.15	0.05	0.03	0.08
4000	0.15	0.14	0.14	0.21	0.22	0.19	0.05	0.04	0.08
4250	0.17	0.15	0.14	0.24	0.28	0.19	0.06	0.04	0.09
4500	0.19	0.17	0.15	0.26	0.32	0.22	0.07	0.04	0.09
4750	0.20	0.18	0.16	0.29	0.37	0.25	0.07	0.05	0.10
5000	0.22	0.20	0.16	0.34	0.43	0.29	0.08	0.06	0.10
5250	0.24	0.22	0.16	0.37	0.47	0.32	0.08	0.06	0.11
5500	0.25	0.23	0.18	0.44	0.54	0.34	0.09	0.07	0.12
5750	0.27	0.25	0.19	0.49	0.59	0.45	0.10	0.07	0.12
6000	0.29	0.27	0.20	0.54	0.64	0.52	0.10	0.08	0.13

BLOWER DATA

CEILING DIFFUSERS AIR RESISTANCE - in. w.g.

Size	RTD11 Step-Down Diffuser				FD11 Flush Diffuser
	Air Volume cfm	2 Ends Open	1 Side, 2 Ends Open	All Ends & Sides Open	
092	2400	0.21	0.18	0.15	0.14
	2600	0.24	0.21	0.18	0.17
	2800	0.27	0.24	0.21	0.20
	3000	0.32	0.29	0.25	0.25
	3200	0.41	0.37	0.32	0.31
	3400	0.50	0.45	0.39	0.37
	3600	0.61	0.54	0.48	0.44
	3800	0.73	0.63	0.57	0.51
102 & 120	3600	0.36	0.28	0.23	0.15
	3800	0.40	0.32	0.26	0.18
	4000	0.44	0.36	0.29	0.21
	4200	0.49	0.40	0.33	0.24
	4400	0.54	0.44	0.37	0.27
	4600	0.60	0.49	0.42	0.31
	4800	0.65	0.53	0.46	0.35
	5000	0.69	0.58	0.50	0.39
150	5200	0.75	0.62	0.54	0.43
	4200	0.22	0.19	0.16	0.10
	4400	0.28	0.24	0.20	0.12
	4600	0.34	0.29	0.24	0.15
	4800	0.40	0.34	0.29	0.19
	5000	0.46	0.39	0.34	0.23
	5200	0.52	0.44	0.39	0.27
	5400	0.58	0.49	0.43	0.31
	5600	0.64	0.54	0.47	0.35
5800	0.70	0.59	0.51	0.39	

CEILING DIFFUSER AIR THROW DATA

Size	Air Volume cfm	¹ Effective Throw Range	
		RTD11 Step-Down	FD11 Flush
		ft.	ft.
092	2600	24 - 29	19 - 24
	2800	25 - 30	20 - 28
	3000	27 - 33	21 - 29
	3200	28 - 35	22 - 29
	3400	30 - 37	22 - 30
102, 120	3600	25 - 33	22 - 29
	3800	27 - 35	22 - 30
	4000	29 - 37	24 - 33
	4200	32 - 40	26 - 35
	4400	34 - 42	28 - 37
150	5600	39 - 49	28 - 37
	5800	42 - 51	29 - 38
	6000	44 - 54	40 - 50
	6200	45 - 55	42 - 51
	6400	46 - 55	43 - 52
	6600	47 - 56	45 - 56

¹ Throw is the horizontal or vertical distance an air stream travels on leaving the outlet or diffuser before the maximum velocity is reduced to 50 ft. per minute. Four sides open.

ELECTRICAL DATA

7.5 TON

Model		LGX092S5								
¹ Voltage - 60Hz		208/230V - 3 Ph			460V - 3 Ph			575V - 3 Ph		
Compressor 1 (Non-Inverter)	Rated Load Amps	12.4			6.5			4.8		
	Locked Rotor Amps	93			60			41		
Compressor 2 (Non-Inverter)	Rated Load Amps	12.8			5.1			4.5		
	Locked Rotor Amps	97.5			44.3			27.1		
Outdoor Fan Motors (2)	Full Load Amps (2 Non-ECM)	2.4			1.3			1		
	Total	4.8			2.6			2		
Power Exhaust (1) 0.33 HP	Full Load Amps	2.4			1.3			1		
Service Outlet 115V GFI (amps)		15			15			20		
Indoor Blower Motor	HP	2	3	5	2	3	5	2	3	5
	Full Load Amps	7.5	10.6	16.7	3.4	4.8	7.6	2.7	3.9	6.1
² Maximum Overcurrent Protection (MOCP)	Unit Only	50	50	60	25	25	30	20	20	25
	With (1) 0.33 HP Power Exhaust	50	50	60	25	25	30	20	20	25
³ Minimum Circuit Ampacity (MCA)	Unit Only	41	44	51	20	21	24	16	17	19
	With (1) 0.33 HP Power Exhaust	44	47	54	21	22	26	17	18	20

ELECTRICAL ACCESSORIES

Disconnect 80 amp **54W56** (all models)

Disconnects - 54W56 - 80A

NOTE - All units have a minimum Short Circuit Current Rating (SCCR) of 5000 amps.

¹ Extremes of operating range are plus and minus 10% of line voltage.

² HACR type breaker or fuse.

³ Refer to National or Canadian Electrical Code manual to determine wire, fuse and disconnect size requirements.

ELECTRICAL DATA

8.5 TON

Model		LGX102S5								
¹ Voltage - 60Hz		208/230V - 3 Ph			460V - 3 Ph			575V - 3 Ph		
Compressor 1 (Non-Inverter)	Rated Load Amps	12.4			6.5			4.8		
	Locked Rotor Amps	93			60			41		
Compressor 2 (Non-Inverter)	Rated Load Amps	12.2			6.4			5.1		
	Locked Rotor Amps	120.4			50			41		
Outdoor Fan Motors (2)	Full Load Amps (2 Non-ECM)	2.4			1.3			1		
	Total	4.8			2.6			2		
Power Exhaust (1) 0.33 HP	Full Load Amps	2.4			1.3			1		
Service Outlet 115V GFI (amps)		15			15			20		
Indoor Blower Motor	HP	2	3	5	2	3	5	2	3	5
	Full Load Amps	7.5	10.6	16.7	3.4	4.8	7.6	2.7	3.9	6.1
² Maximum Overcurrent Protection (MOCP)	Unit Only	50	50	60	25	25	30	20	20	25
	With (1) 0.33 HP Power Exhaust	50	50	60	25	25	30	20	20	25
³ Minimum Circuit Ampacity (MCA)	Unit Only	40	44	51	21	22	25	16	18	20
	With (1) 0.33 HP Power Exhaust	43	46	53	22	24	27	17	19	21

ELECTRICAL ACCESSORIES

Disconnect 80 amp **54W56** (all models)

Disconnects - 54W56 - 80A

NOTE - All units have a minimum Short Circuit Current Rating (SCCR) of 5000 amps.

¹ Extremes of operating range are plus and minus 10% of line voltage.

² HACR type breaker or fuse.

³ Refer to National or Canadian Electrical Code manual to determine wire, fuse and disconnect size requirements.

ELECTRICAL DATA

10 TON

Model		LGX120S5								
¹ Voltage - 60Hz		208/230V - 3 Ph			460V - 3 Ph			575V - 3 Ph		
Compressor 1 (Non-Inverter)	Rated Load Amps	12.4			6.5			4.8		
	Locked Rotor Amps	93			60			41		
Compressor 2 (Non-Inverter)	Rated Load Amps	16			7.1			6.4		
	Locked Rotor Amps	156.4			69			47.8		
Outdoor Fan Motors (2)	Full Load Amps (2 Non-ECM)	3			1.5			1.2		
	Total	6			3			2.4		
Power Exhaust (1) 0.33 HP	Full Load Amps	2.4			1.3			1		
Service Outlet 115V GFI (amps)		15			15			20		
Indoor Blower Motor	HP	2	3	5	2	3	5	2	3	5
	Full Load Amps	7.5	10.6	16.7	3.4	4.8	7.6	2.7	3.9	6.1
² Maximum Overcurrent Protection (MOCP)	Unit Only	60	60	70	25	30	30	20	25	25
	With (1) 0.33 HP Power Exhaust	60	60	70	30	30	30	25	25	25
³ Minimum Circuit Ampacity (MCA)	Unit Only	46	49	56	22	24	27	18	20	22
	With (1) 0.33 HP Power Exhaust	49	52	58	24	25	28	19	21	23

ELECTRICAL ACCESSORIES

Disconnect 80 amp **54W56** (all models)

Disconnects - 54W56 - 80A

NOTE - All units have a minimum Short Circuit Current Rating (SCCR) of 5000 amps.

¹ 1 Extremes of operating range are plus and minus 10% of line voltage.

² 2 HACR type breaker or fuse.

³ 3 Refer to National or Canadian Electrical Code manual to determine wire, fuse and disconnect size requirements.

ELECTRICAL DATA

12.5 TON

Model		LGX150S5								
¹ Voltage - 60Hz		208/230V - 3 Ph			460V - 3 Ph			575V - 3 Ph		
Compressor 1 (Non-Inverter)	Rated Load Amps	19.2			9.1			6.2		
	Locked Rotor Amps	162.3			70.8			58.2		
Compressor 2 (Non-Inverter)	Rated Load Amps	22.4			9.1			7.2		
	Locked Rotor Amps	166.2			74.6			54		
Outdoor Fan Motors (2)	Full Load Amps (2 Non-ECM)	3			1.5			1.2		
	Total	6			3			2.4		
Power Exhaust (1) 0.33 HP	Full Load Amps	2.4			1.3			1		
Service Outlet 115V GFI (amps)		15			15			20		
Indoor Blower Motor	HP	2	3	5	2	3	5	2	3	5
	Full Load Amps	7.5	10.6	16.7	3.4	4.8	7.6	2.7	3.9	6.1
² Maximum Overcurrent Protection (MOCP)	Unit Only	80	80	90	35	35	40	25	25	30
	With (1) 0.33 HP Power Exhaust	80	80	90	35	35	40	25	25	30
³ Minimum Circuit Ampacity (MCA)	Unit Only	61	64	70	27	29	32	21	22	24
	With (1) 0.33 HP Power Exhaust	64	67	73	29	30	33	22	23	25

ELECTRICAL ACCESSORIES

Disconnect 80 amp **54W56** (all models)

Disconnects - 54W56 - 80A

NOTE - All units have a minimum Short Circuit Current Rating (SCCR) of 5000 amps.

¹ Extremes of operating range are plus and minus 10% of line voltage.

² HACR type breaker or fuse.

³ Refer to National or Canadian Electrical Code manual to determine wire, fuse and disconnect size requirements.

FIELD WIRING NOTES

- For use with copper wiring only
- Field wiring not furnished
- All wiring must conform to NEC or CEC and local electrical codes
- For specific wiring information, please refer to the installation instructions

UNIT CLEARANCES

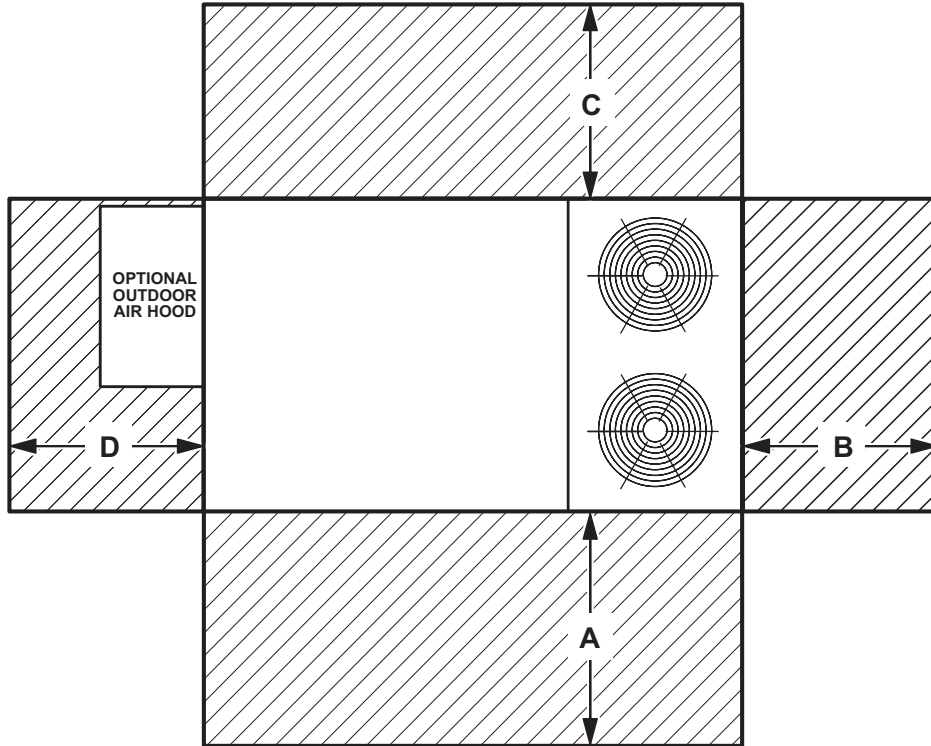

1 Unit Clearance	A		B		C		D		Top Clearance
	in.	mm	in.	mm	in.	mm	in.	mm	
Service Clearance	60	1524	36	914	36	914	60	1524	Unobstructed
Clearance to Combustibles	36	914	1	25	1	25	1	25	
Minimum Operation Clearance	36	914	36	914	36	914	36	914	

NOTE - Entire perimeter of unit base requires support when elevated above the mounting surface.

¹ Service Clearance - Required for removal of serviceable parts.

Clearance to Combustibles - Required for clearance to combustible material.

Minimum Operation Clearance - Required clearance for proper unit operation.

OUTDOOR SOUND DATA

Size	Octave Band Sound Power Levels dBA, re 10 ⁻¹² Watts - Center Frequency - Hz							1 Sound Rating Number (dBA)
	125	250	500	1000	2000	4000	8000	
092, 102	76	79	84	83	79	73	66	88
120, 150	75	81	87	85	80	73	67	90

Note - The octave sound power data does not include tonal corrections.

¹ Sound Rating Number according to AHRI Standard 270-95 or AHRI Standard 370-2001 (includes pure tone penalty). Sound Rating Number is the overall A-Weighted Sound Power Level, (LWA), dBA (100 Hz to 10,000 Hz).

WEIGHT DATA

Size	Net		Shipping	
	lbs.	kg	lbs.	kg
092S Base Unit	918	416	1003	455
092S Max. Unit	1069	485	1154	523
102S Base Unit	938	425	1023	464
102S Max. Unit	1089	494	1174	533
120S Base Unit	1002	454	1087	493
120S Max. Unit	1153	523	1238	561
150S Base Unit	1052	477	1137	515
150S Max. Unit	1202	545	1287	583

FACTORY / FIELD INSTALLED OPTIONS AND ACCESSORIES - NET WEIGHTS

Description	lbs.	kg	
ECONOMIZER / OUTDOOR AIR / POWER EXHAUST			
Economizer			
Economizer Dampers	56	26	
Barometric Relief Dampers (downflow)	9	4	
Barometric Relief Dampers (low profile horizontal)	20	9	
Outdoor Air Hood (downflow)	21	10	
Outdoor Air Dampers			
Motorized	10	5	
Manual	10	5	
Power Exhaust	31	14	
GAS HEAT EXCHANGER (NET WEIGHT)			
Medium Heat (adder over standard heat)	17	8	
High Heat (adder over standard heat)	33	15	
COIL/HAIL GUARDS			
All models	21	10	
ROOF CURBS			
Hybrid Roof Curbs, Downflow			
8 in. height	103	47	
14 in. height	125	57	
18 in. height	147	67	
24 in. height	169	77	
Adjustable Pitch Curb, Downflow			
14 in. height	169	77	
CEILING DIFFUSERS			
Step-Down	RTD11-95S	118	54
	RTD11-135S	135	61
	RTD11-185S	168	76
Flush	FD11-95S	118	54
	FD11-135S	135	61
	FD11-185S	168	76
Transitions	C1DIFF30B-1	30	14
	C1DIFF31B-1	32	15
	C1DIFF32B-1	36	16
DEHUMIDIFICATION SYSTEM			
Dehumidification Option	20	9	

DIMENSIONS

UNIT

Size	CORNER WEIGHTS														CENTER OF GRAVITY									
	AA				BB				CC				DD				EE				FF			
	Base		Max.		Base		Max.		Base		Max.		Base		Max.		Base		Max.		Base		Max.	
	lbs.	kg	lbs.	kg	lbs.	kg	lbs.	kg	lbs.	kg	lbs.	kg	lbs.	kg	lbs.	kg	in.	mm	in.	mm	in.	mm	in.	mm
092S	236	107	325	147	201	91	264	120	218	99	278	125	264	120	353	160	44-1/2	1130	43-1/2	1105	24-1/2	622	25-1/2	648
102S	241	109	332	150	205	93	269	122	222	101	282	127	270	122	359	163	44-1/2	1130	43-1/2	1105	24-1/2	622	25-1/2	648
120S	255	116	344	155	215	97	276	124	231	105	292	132	285	129	378	171	44	1118	43	1092	24-3/4	629	25-3/4	654
150S	275	125	321	146	232	105	263	119	253	115	282	128	312	142	358	162	44	1118	43	1092	24	610	25	635

Base Unit - The unit with NO OPTIONS.

Max. Unit - The unit with ALL OPTIONS Installed. (Economizer, etc.)

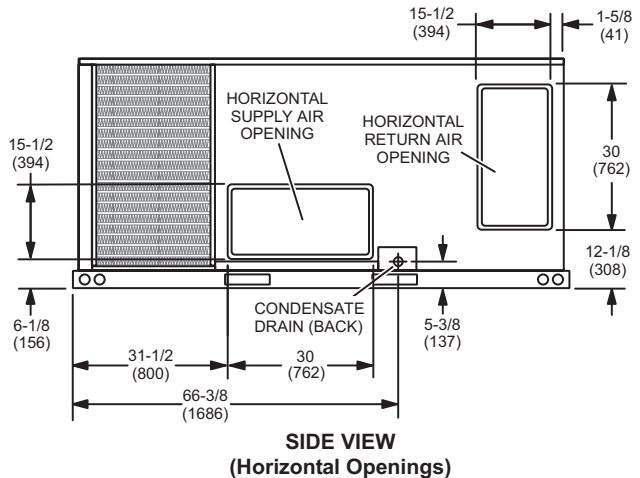
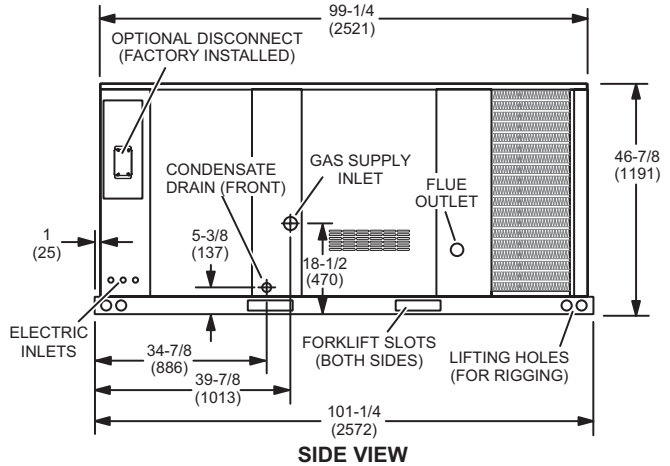
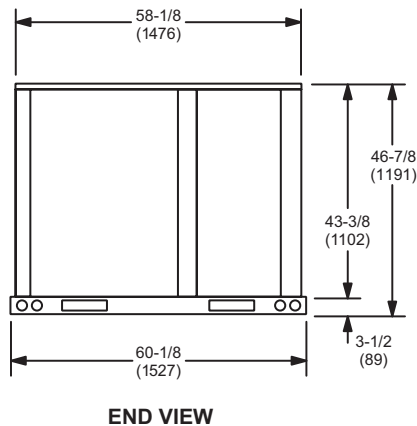
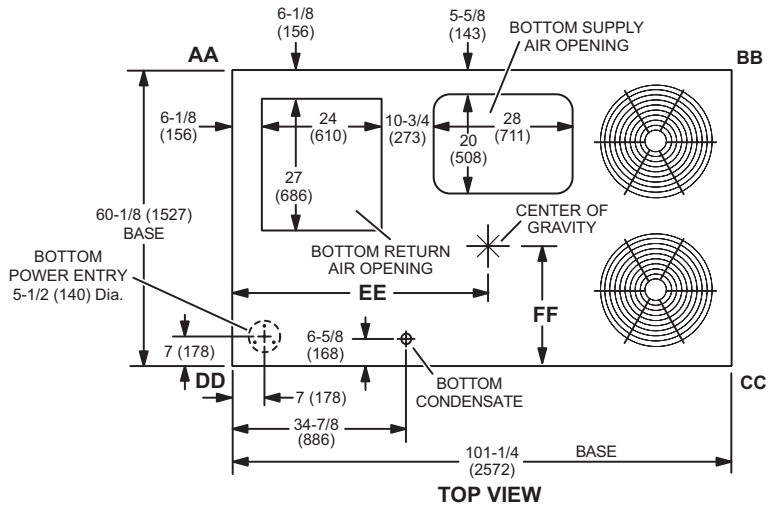

OUTDOOR AIR HOOD DETAIL

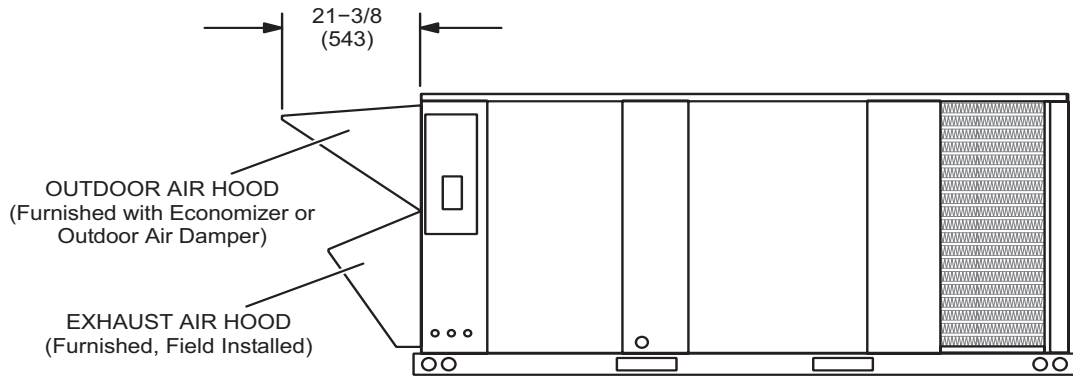

HORIZONTAL ECONOMIZER APPLICATION

(With Furnished Barometric Relief Dampers and Optional Horizontal Discharge Kit - Required)

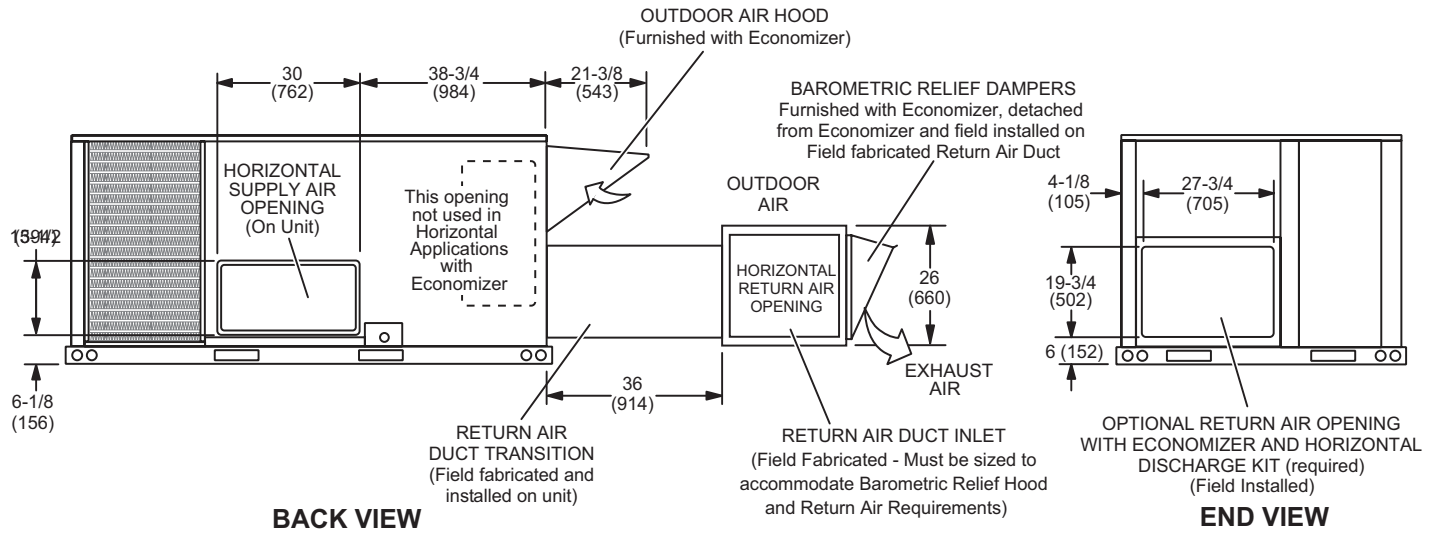
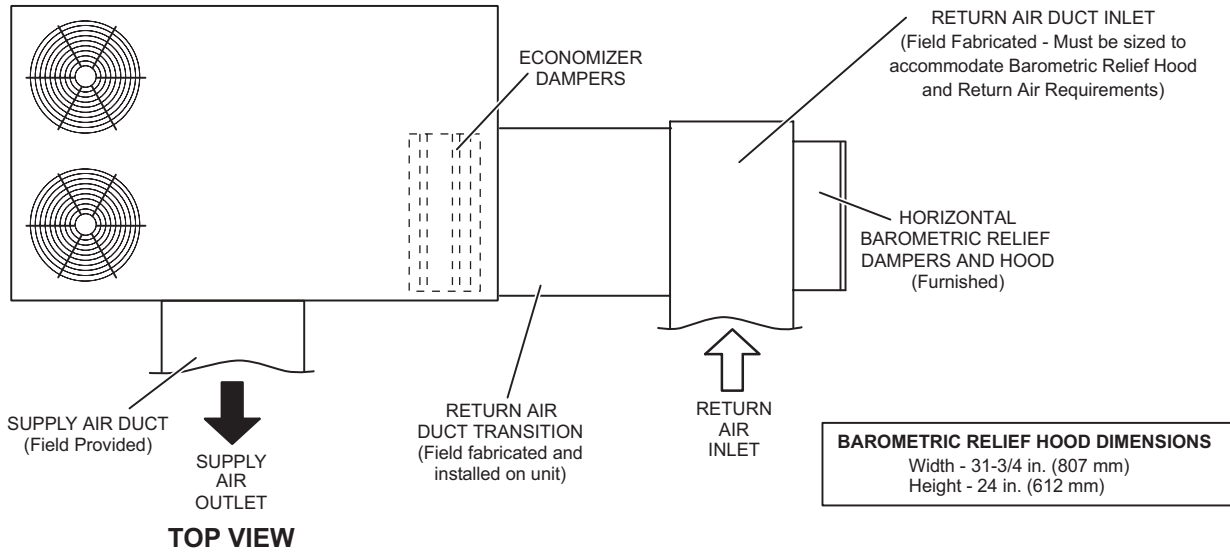

NOTE - Return Air Duct and Transition must be supported.

**BAROMETRIC RELIEF DAMPERS
(Furnished with Economizer)**

(Field installed in horizontal return air duct adjacent to unit)

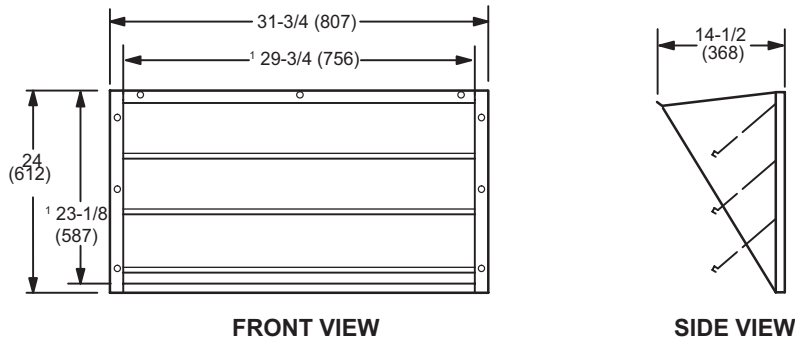

¹ NOTE - Opening size required in return air duct.

HORIZONTAL ECONOMIZER APPLICATION

(with Optional Low Profile Horizontal Barometric Relief Dampers and Horizontal Discharge Kit - Required)

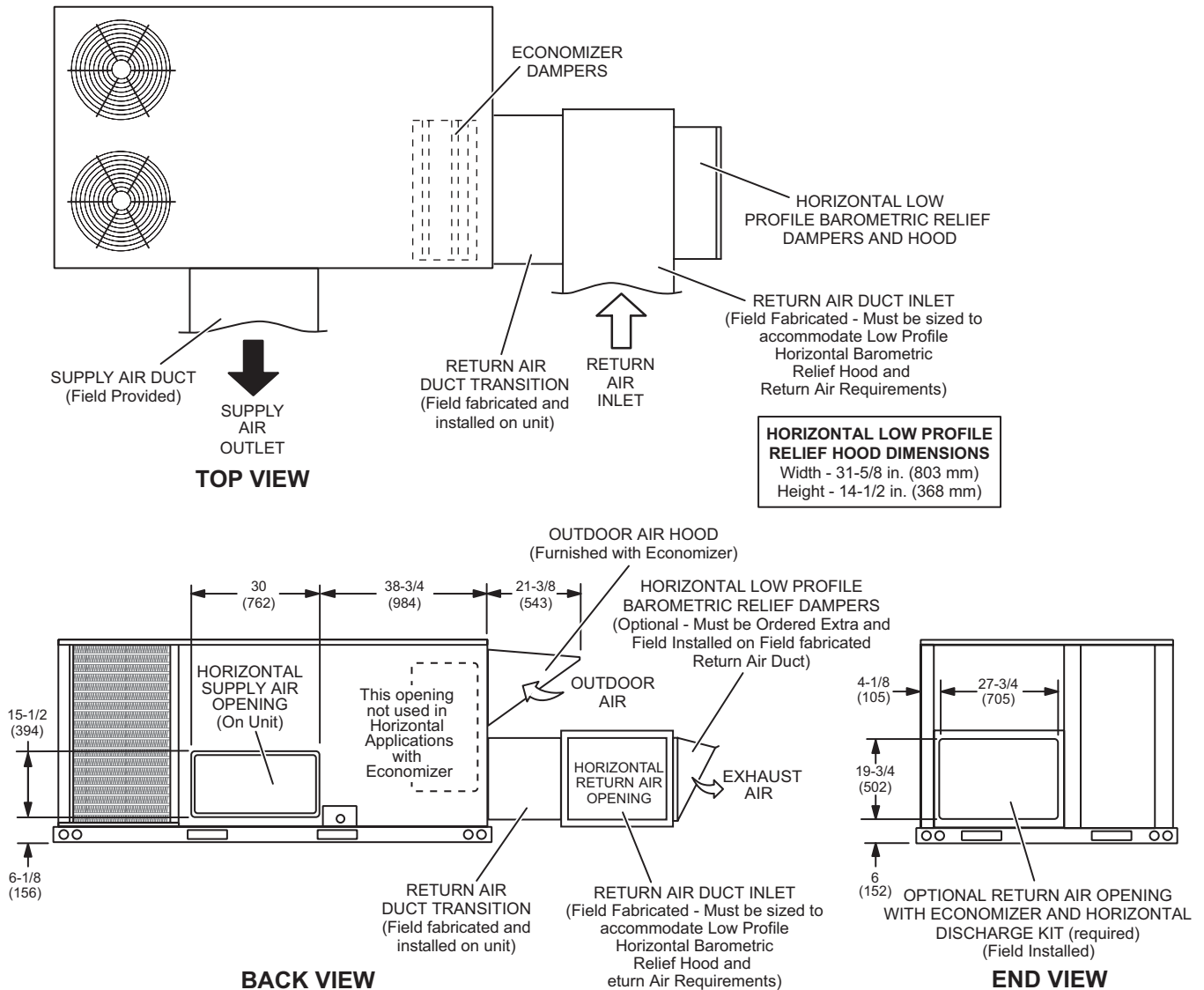

NOTE - Return Air Duct and Transition must be supported.

HORIZONTAL LOW PROFILE BAROMETRIC RELIEF DAMPERS

(Field installed in horizontal return air duct adjacent to unit)

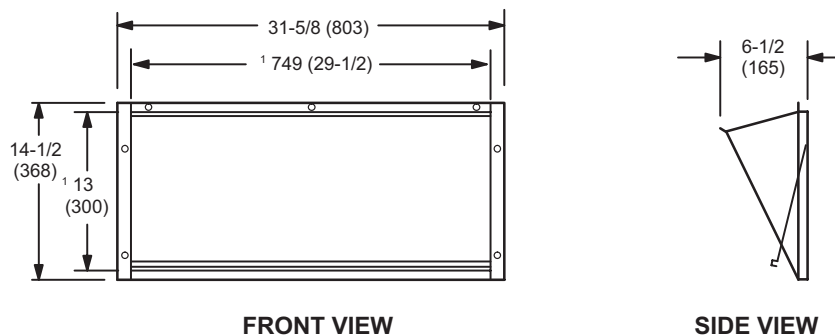

¹ NOTE - Opening size required in return air duct.

HYBRID ROOF CURBS - DOUBLE DUCT OPENING

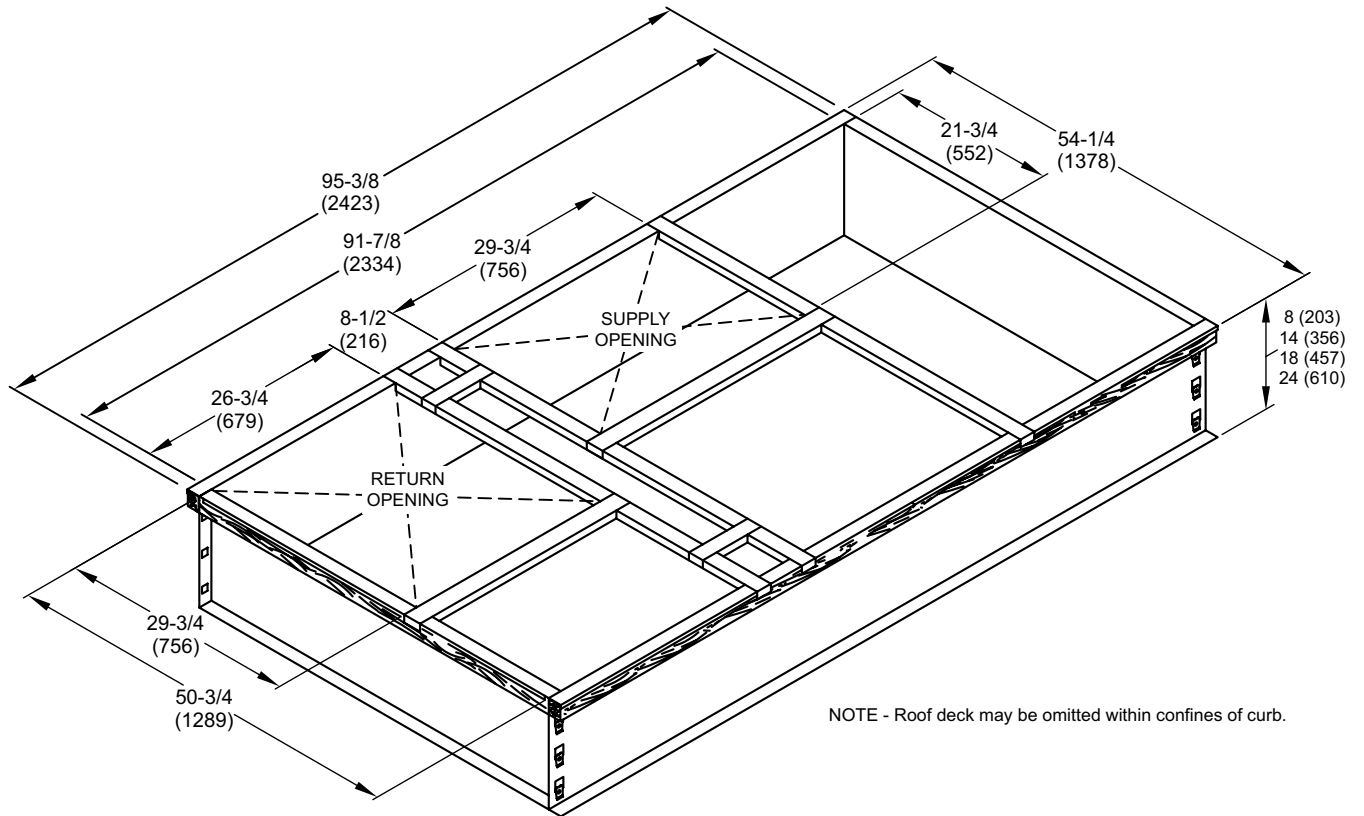

TYPICAL FLASHING DETAIL FOR ROOF CURB

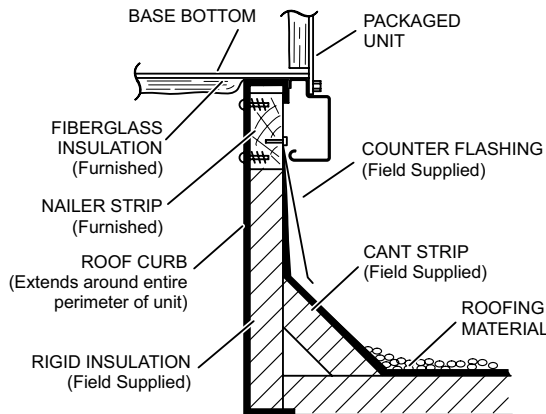

DETAIL ROOF CURB

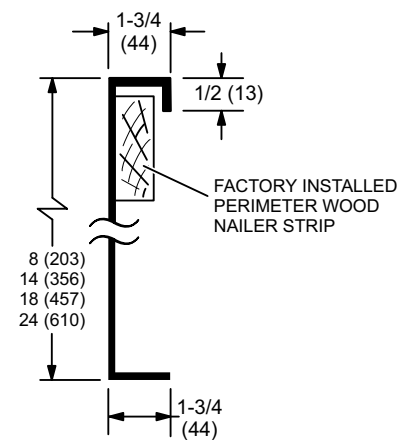

ADJUSTABLE PITCH CURBS - DOUBLE DUCT OPENING

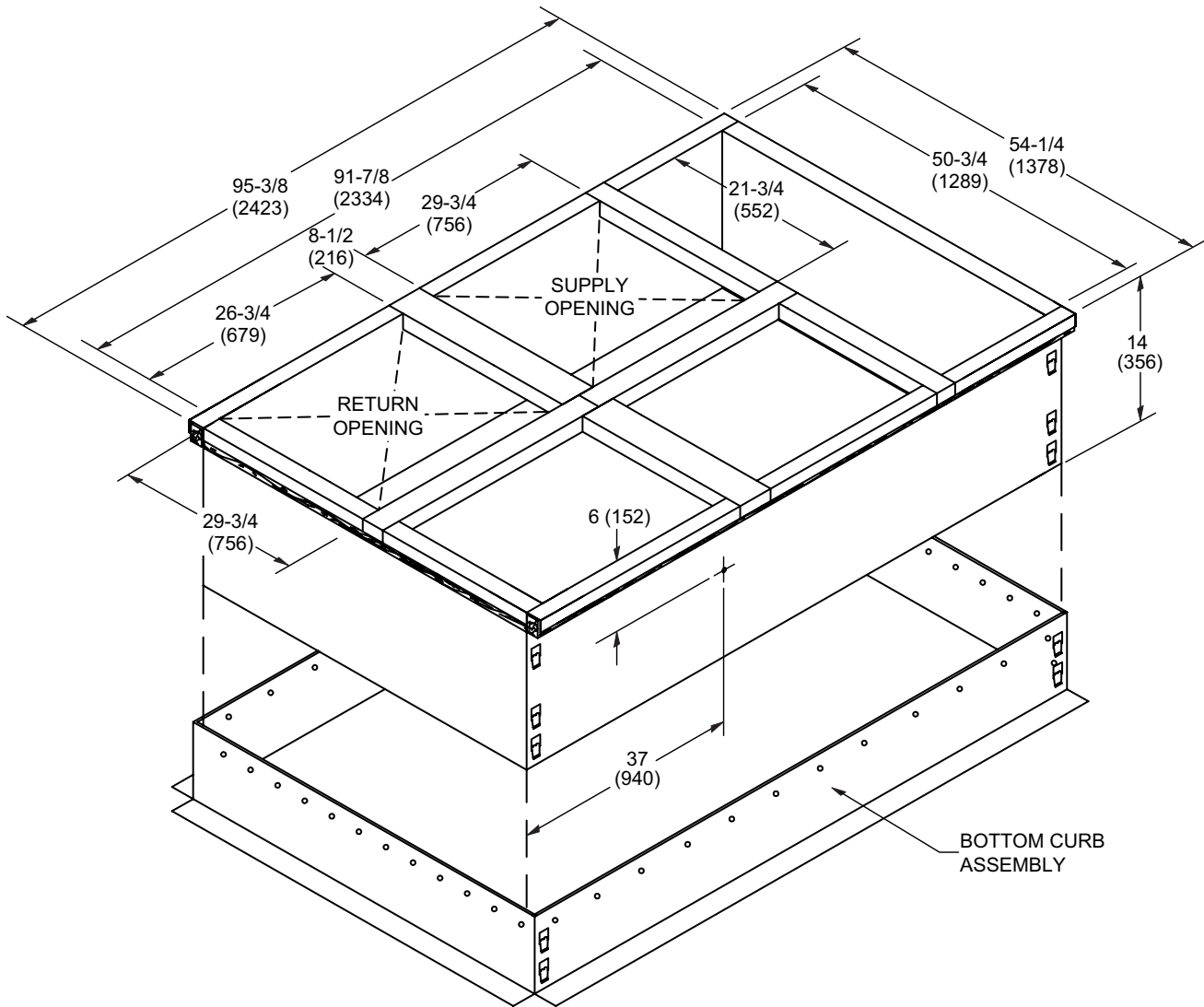

NOTE - Maximum slope pitch is 3/4 in. per 1 foot (19 mm per 305 mm) in any one direction.

TYPICAL FLASHING DETAIL FOR ROOF CURB

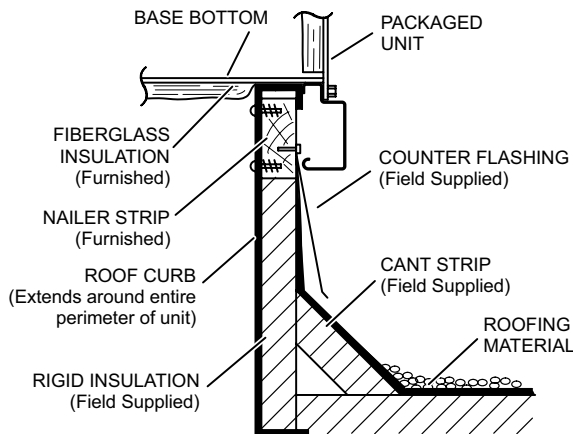

DETAIL ROOF CURB

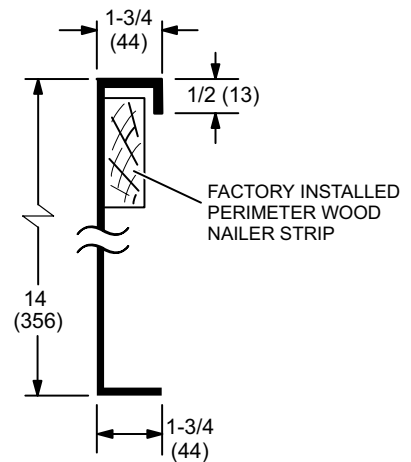

ROOF CURBS WITH SUPPLY & RETURN AIR TRANSITIONS FOR CEILING DIFFUSERS

C1DIFF30B-1 ROUND TRANSITIONS
(for 092 models)

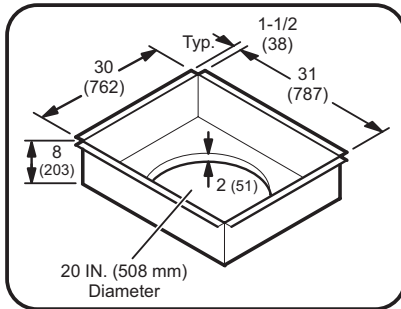

C1DIFF31B-1 & C1DIFF32B-1 RECTANGULAR TRANSITIONS
(for 102 thru 150 models)

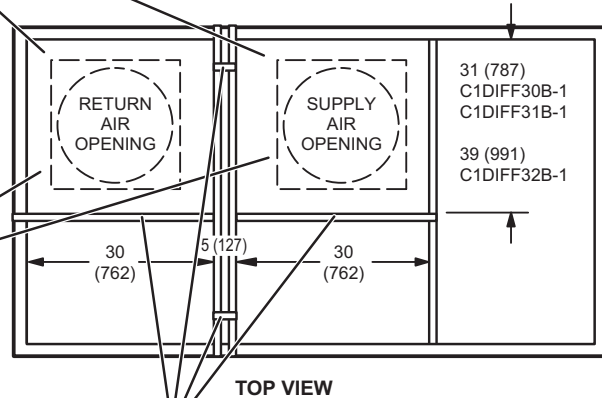
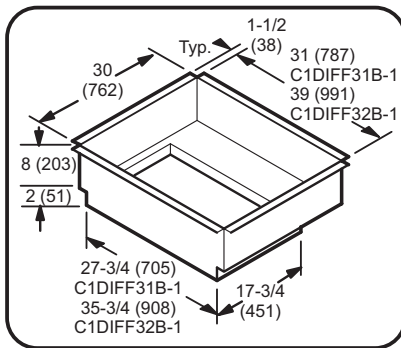

TOP VIEW

NOTE - These four supports are furnished with the transitions to replace supports furnished with curb for proper transition spacing.

COMBINATION CEILING SUPPLY AND RETURN DIFFUSERS

STEP-DOWN CEILING DIFFUSER

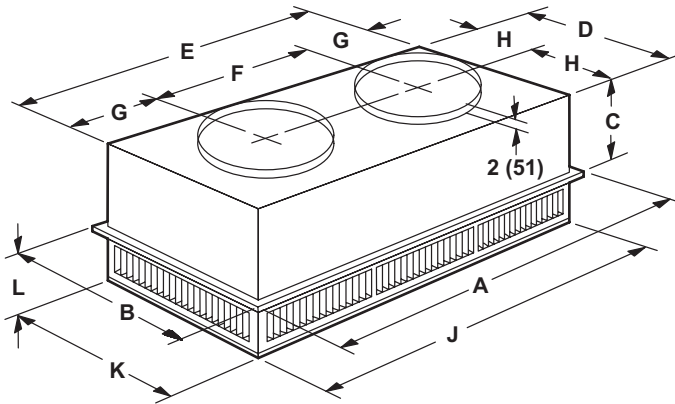

FLUSH CEILING DIFFUSER

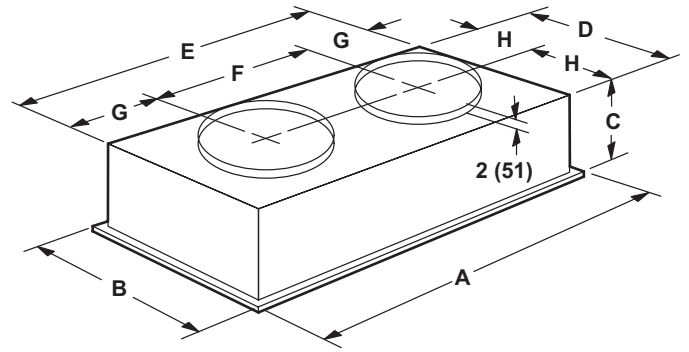

Model		RTD11-95S
A	in.	47-5/8
	mm	1159
B	in.	29-5/8
	mm	752
C	in.	14-3/8
	mm	365
D	in.	27-1/2
	mm	699
E	in.	45-1/2
	mm	1158
F	in.	22-1/2
	mm	572
G	in.	11-1/2
	mm	292
H	in.	13-3/4
	mm	349
J	in.	45-1/2
	mm	1156
K	in.	27-1/2
	mm	699
L	in.	8-1/8
	mm	206
Duct Size	in.	20 round
	mm	508 round

Model		FD11-95S
A	in.	47-5/8
	mm	1159
B	in.	29-5/8
	mm	752
C	in.	16-5/8
	mm	422
D	in.	27
	mm	686
E	in.	45
	mm	1143
F	in.	22-1/2
	mm	572
G	in.	11-1/4
	mm	286
H	in.	13-1/2
	mm	343
Duct Size	in.	20 round
	mm	508 round

COMBINATION CEILING SUPPLY AND RETURN DIFFUSERS

STEP-DOWN CEILING DIFFUSER

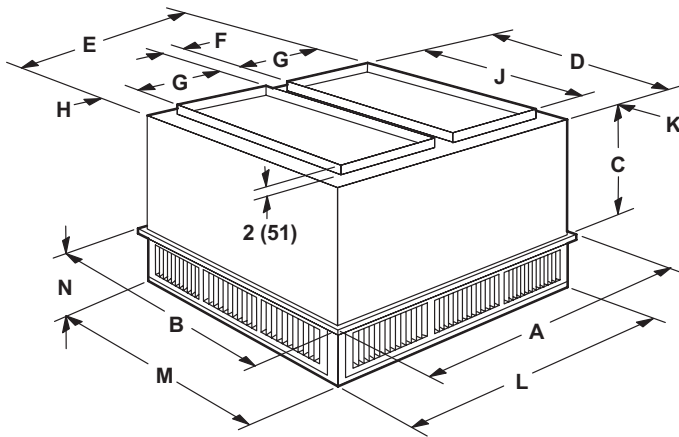

FLUSH CEILING DIFFUSER

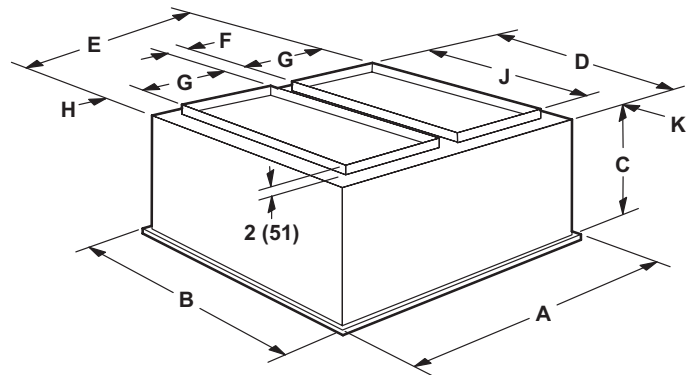

Model		RTD11-135S	RTD11-185S
A	in.	47-5/8	47-5/8
	mm	1210	1210
B	in.	35-5/8	47-5/8
	mm	905	1210
C	in.	20-5/8	24-5/8
	mm	524	625
D	in.	33-1/2	45-1/2
	mm	851	1156
E	in.	45-1/2	45-1/2
	mm	1156	1156
F	in.	4-1/2	4-1/2
	mm	114	114
G	in.	18	18
	mm	457	457
H	in.	2-1/2	2-1/2
	mm	64	64
J	in.	28	36
	mm	711	914
K	in.	2-3/4	4-3/4
	mm	70	121
L	in.	45-1/2	45-1/2
	mm	1156	1156
M	in.	33-1/2	45-1/2
	mm	851	1156
N	in.	9-1/8	10-1/8
	mm	232	257
Duct Size	in.	18 x 28	18 x 36
	mm	457 x 711	457 x 914

Model		FD11-135S	FD11-185S
A	in.	47-5/8	47-5/8
	mm	1210	1210
B	in.	35-5/8	47-5/8
	mm	905	1210
C	in.	23-1/4	29-1/4
	mm	591	743
D	in.	33	45
	mm	838	1143
E	in.	45	45
	mm	1143	1143
F	in.	4-1/2	4-1/2
	mm	114	114
G	in.	18	18
	mm	457	457
H	in.	2-1/4	2-1/4
	mm	57	57
J	in.	28	36
	mm	711	914
K	in.	2-1/2	4-1/2
	mm	64	114
Duct Size	in.	18 x 28	18 x 36
	mm	457 x 711	457 x 914



Visit us at www.allied-commercial.com

For the latest technical information, visit us at www.allied-commercial.com

Contact us at 1-800-448-5872

NOTE - Due to Allied Commercial ongoing commitment to quality, Specifications, Ratings and Dimensions subject to change without notice and without incurring liability. Improper installation, adjustment, alteration, service or maintenance can cause property damage or personal injury. Installation and service must be performed by a qualified installer and servicing agency.