

PACKAGED UNITS KITS AND ACCESSORIES

507913-01
1/2020
Supersedes 6/2019

ZERO DEGREE LOW AMBIENT KIT

INSTALLATION INSTRUCTIONS FOR LOW AMBIENT KIT USED ON KG/KC 092-150 PACKAGED ROOFTOP UNITS

Shipping and Packing List

Package 1 of 1 contains:

- 1- Head pressure control (A190)
- 2- Wiring harnesses
- 1- Bag assembly containing:
 - 2-Pressure transducers (A188, A189)
 - 2-Valve depressors tees
 - 10-Wire ties
 - 1-Wiring diagram
 - 2-Self tapping
 - 2-High pressure switches (KGA/KCA only - 18B87)

Application

This kit allows low ambient operation to 0°F (-17.8°C) unless otherwise noted in product specifications.

During low ambient conditions, the liquid line pressure will fall. If the pressure gets too low, the low ambient kit, instead of shutting down the condenser fan, slows down the condenser fan until the liquid line pressure rises to the set point.

See table 1 for usage.

TABLE 1

Unit	Cat. #	LB #
KG/KC 092-120 KGA/KCA 150	18B87	619589-01
KGB/KCB 150	18B94	619589-02

Operation

Liquid line pressure switches (A188 & A189) will de-energize condenser fans below 355 psig preventing low ambient operation. Liquid line pressure transducers are installed to convert the pressure to an analog signal which is sent to the head pressure control (A190). The head pressure control provides a variable output which slows condenser fan operation at lower ambient temperatures (A190 terminal M to K10 normally open contacts). Lower fan speeds increase the liquid line pressure allowing operation above 355 psig.

⚠️ WARNING

Improper installation, adjustment, alteration, service or maintenance can cause property damage, personal injury or loss of life. Installation and service must be performed by a licensed professional HVAC installer or equivalent, service agency, or the gas supplier

Installation

- 1- Disconnect power to unit and open access panels.
- 2- Install the head pressure control in the control section as shown in figure 1. Secure with self-tapping screws (provided).
- 3- Set the head pressure control as follows:
 - Setpoint: 355 psig
 - Hard Start: Min.
 - Cut-out Speed: Set to 5th marker from minimum
 - Heat Pump Pin set to :N.O.

⚠️ CAUTION

As with any mechanical equipment, contact with sharp sheet metal edges can result in personal injury. Take care while handling this equipment and wear gloves and protective clothing.

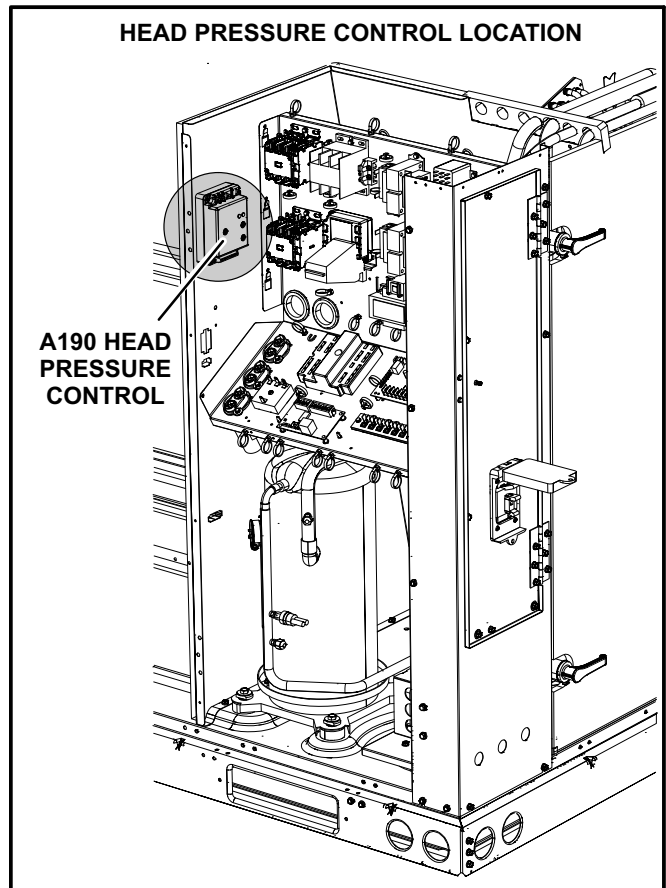

FIGURE 1

- 4- If present, disconnect and discard low pressure switches from each liquid line. See figure 2.
- 5- Install the valve depressor tee on each liquid line pressure tap.
- 6- Install a pressure transducer on each depressor tee.
- 7- *KGA/KCA Unit Only* -
Disconnect and discard the existing high pressure switches. Install pressure switches provided in this kit.

Wire Pressure Transducers (A188, A189)

- 1- Lift the unit top and prop open near the foam block. See figure 2.
- 2- Route the transducer wires through the convoluted tubing into the control area.
- 3- Make wire connections as shown in figure 3.

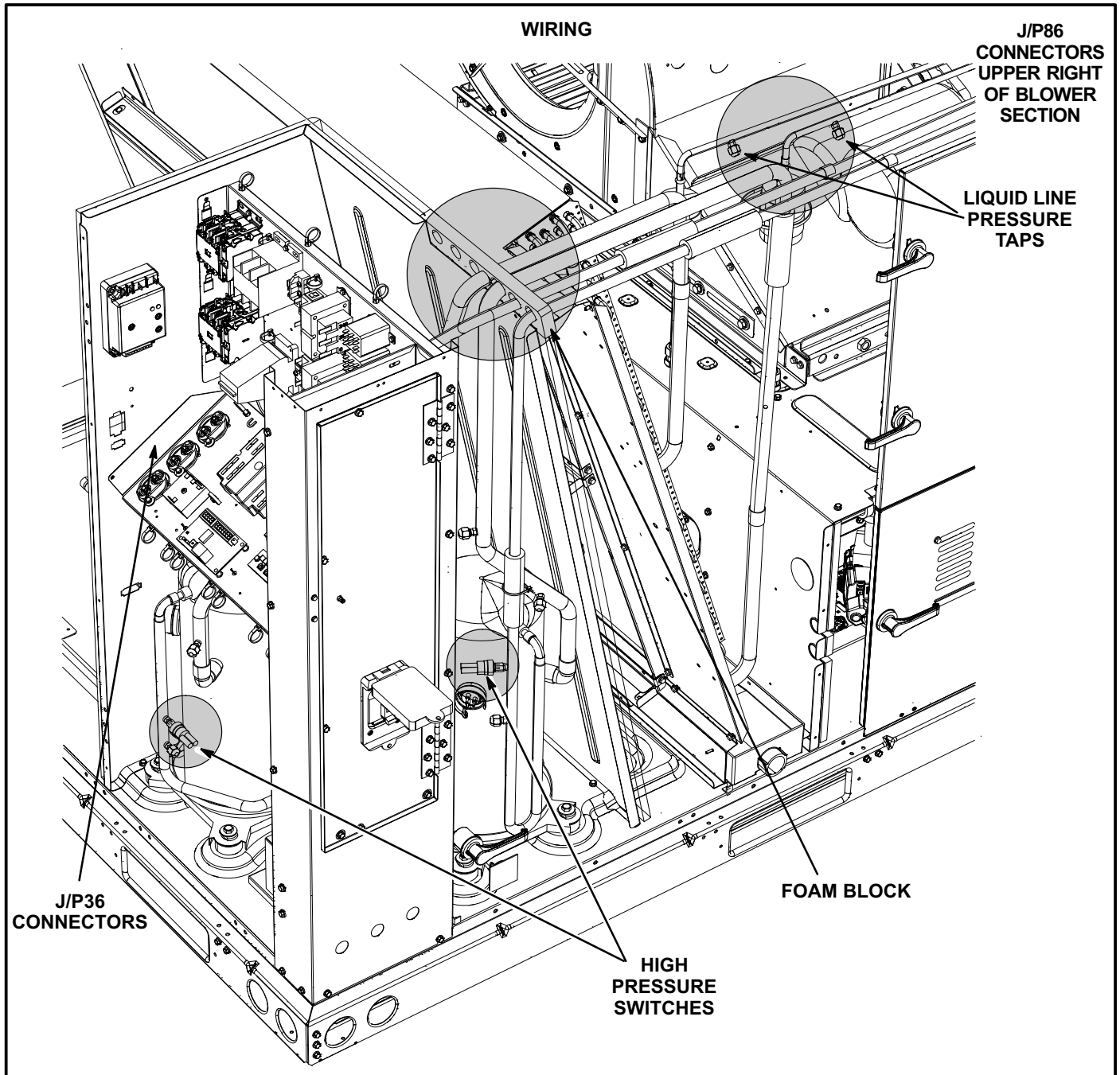

FIGURE 2

Wire Head Pressure Control (A190)

- 1- *KG/KC 092-120 & KGA/KCA 150 Units -*
Disconnect J/P36 connectors in the lower left area of the control box. See figure 2.
KGB/KCB150 Units -
Disconnect J/P86 connectors located in the upper right of the blower section. See figure 2.
- 2- Remove K10 power terminal connectors; do not remove wiring routed to K10-A & B coil. Trace wires back to the contactor(s) and to transformer T1.

Disconnect and discard wires and P36 connector. On KGB/KCB150 units, remove power terminal connectors on K68-7 & 4. Trace back and disconnect in the same manner.

- 3- Install the power wiring harness as shown in figure 4.
- 4- Bundle wiring and use wire ties to route wiring away from sharp edges.
- 5- Place the wiring diagram provided in this kit on the inside of the control door.
- 6- Close unit panels and restore power.

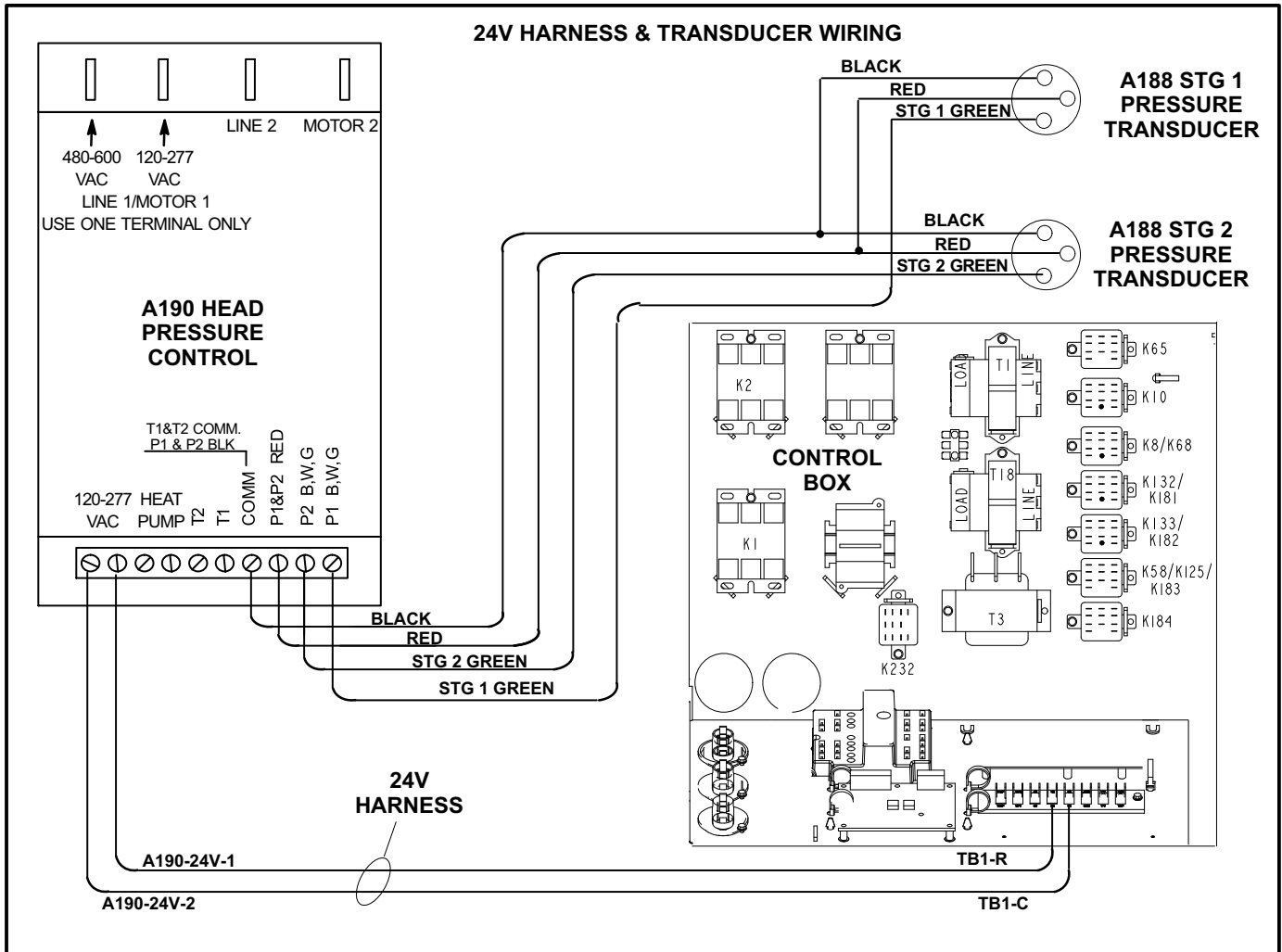

FIGURE 3

POWER HARNESS WIRING

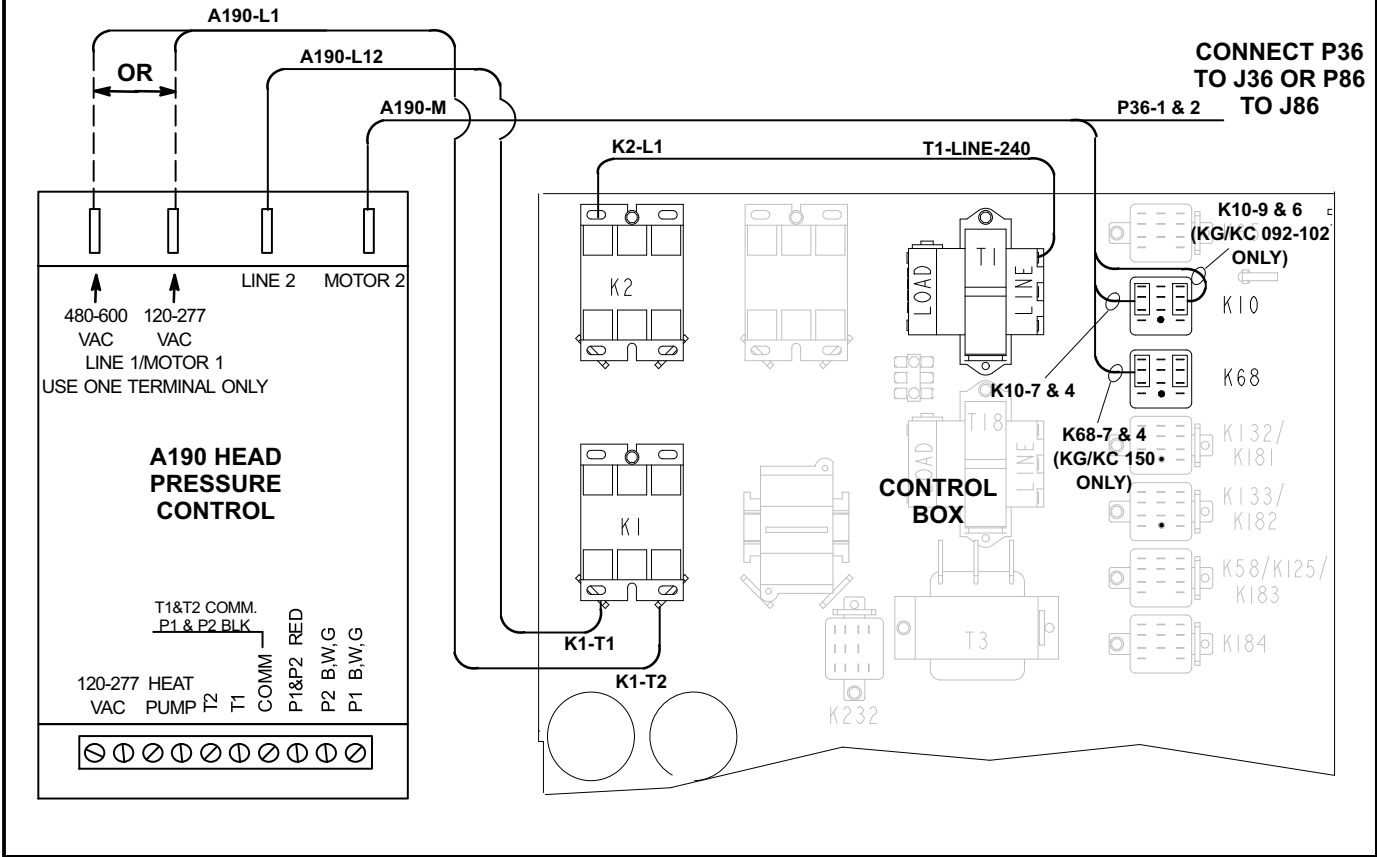

FIGURE 4