

# INSTALLATION INSTRUCTIONS

## ⚠ WARNING

To prevent serious injury or death:

- 1- Lock-out/tag-out before performing maintenance.
- 2- If system power is required (e.g., smoke detector maintenance), disable power to blower, remove fan belt where applicable, and ensure all controllers and thermostats are set to the "OFF" position before performing maintenance.
- 3- Always keep hands, hair, clothing, jewelry, tools, etc., away from moving parts.

### Table Of Contents

Dimensions .....	Page 2
Parts Arrangements .....	Page 3
Shipping and Packing List .....	Page 4
General .....	Page 4
Safety .....	Page 4
Unit Support .....	Page 5
Duct Connection .....	Page 6
Rigging Unit For Lifting .....	Page 6
Condensate Drains .....	Page 6
Gas Piping .....	Page 8
Pressure Test Gas Piping .....	Page 9
High Altitude Derate .....	Page 10
Download Mobile Service App .....	Page 10
Electrical Connections - Power Supply .....	Page 10
Electrical Connections - Control Wiring .....	Page 11
Blower Operation and Adjustments .....	Page 13
Direct Drive Start-Up .....	Page 15
Cooling Start-Up .....	Page 18

<b>LGT/LCT092H</b>	(7.5 Ton)
<b>LGT/LCT102H</b>	(8.5 Ton)
<b>LGT/LCT120H</b>	(10 Ton)
<b>LGT/LCT150H</b>	(12.5 Ton)

PACKAGED UNITS  
508287-01  
10/2022

## ⚠ WARNING

**Improper installation, adjustment, alteration, service or maintenance can cause property damage, personal injury or loss of life. Installation and service must be performed by a licensed professional HVAC installer or equivalent, service agency, or the gas supplier.**

Prognostic & Diagnostic Sensors .....	Page 24
Gas Heat Start-Up .....	Page 26
Heating Operation and Adjustments .....	Page 27
Electric Heat Start-Up .....	Page 27
Cooling Operation .....	Page 28
Modulating Hot Gas Reheat .....	Page 29
Service .....	Page 31
Field-Installed Accessories .....	Page 37
Unit Controller Parameter Settings .....	Page 37

### Attention!

Use this QR code to download the mobile service app. Follow the prompts to pair the app with the unit control system and configure the unit. Refer to the "Download Mobile App" section in this manual and the Setup Guide provided with this unit. The QR code is also available in the unit control area.



The app can be downloaded from the appropriate iOS or Android store. Look for the following icon.



# ⚠ CAUTION

As with any mechanical equipment, contact with sharp sheet metal edges can result in personal injury. Take care while handling this equipment and wear gloves and protective clothing.

## LGT/LCT092, 102, 120, & 150 DIMENSIONS - GAS HEAT SECTION SHOWN

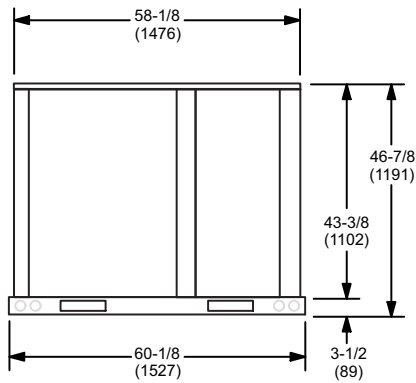
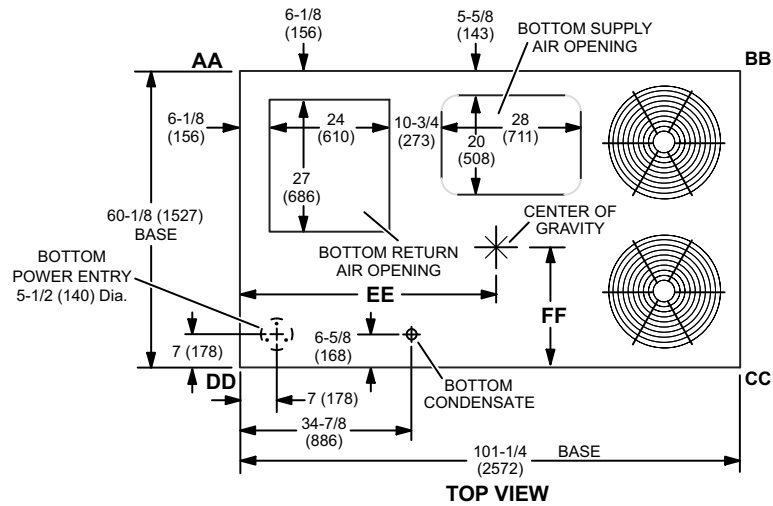

END VIEW

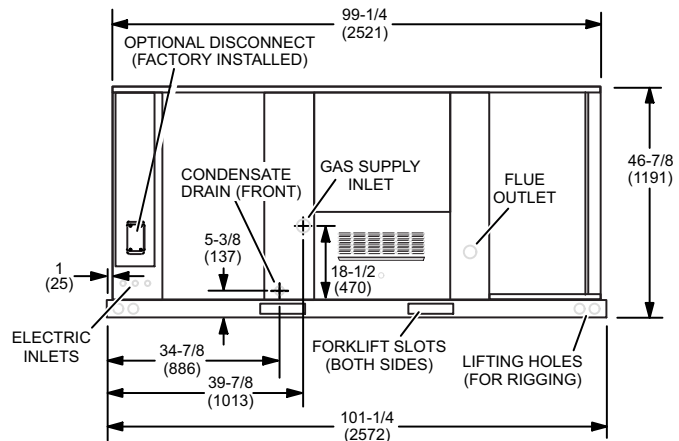

SIDE VIEW

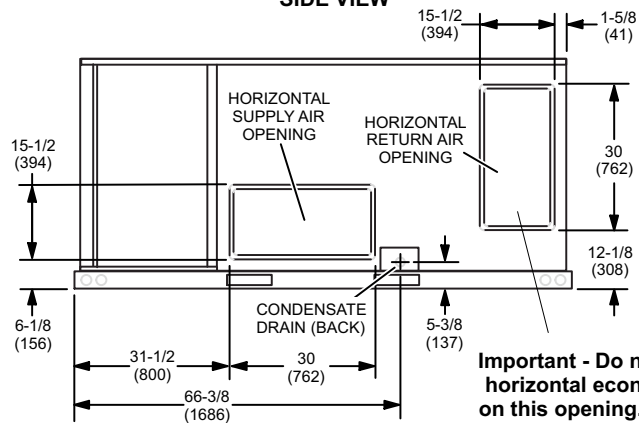

SIDE VIEW  
(Horizontal Openings)

**Important - Do not install horizontal economizers on this opening. Refer to economizer instructions for proper installation.**

**LGT092, 102, 120, 150 PARTS ARRANGEMENT**

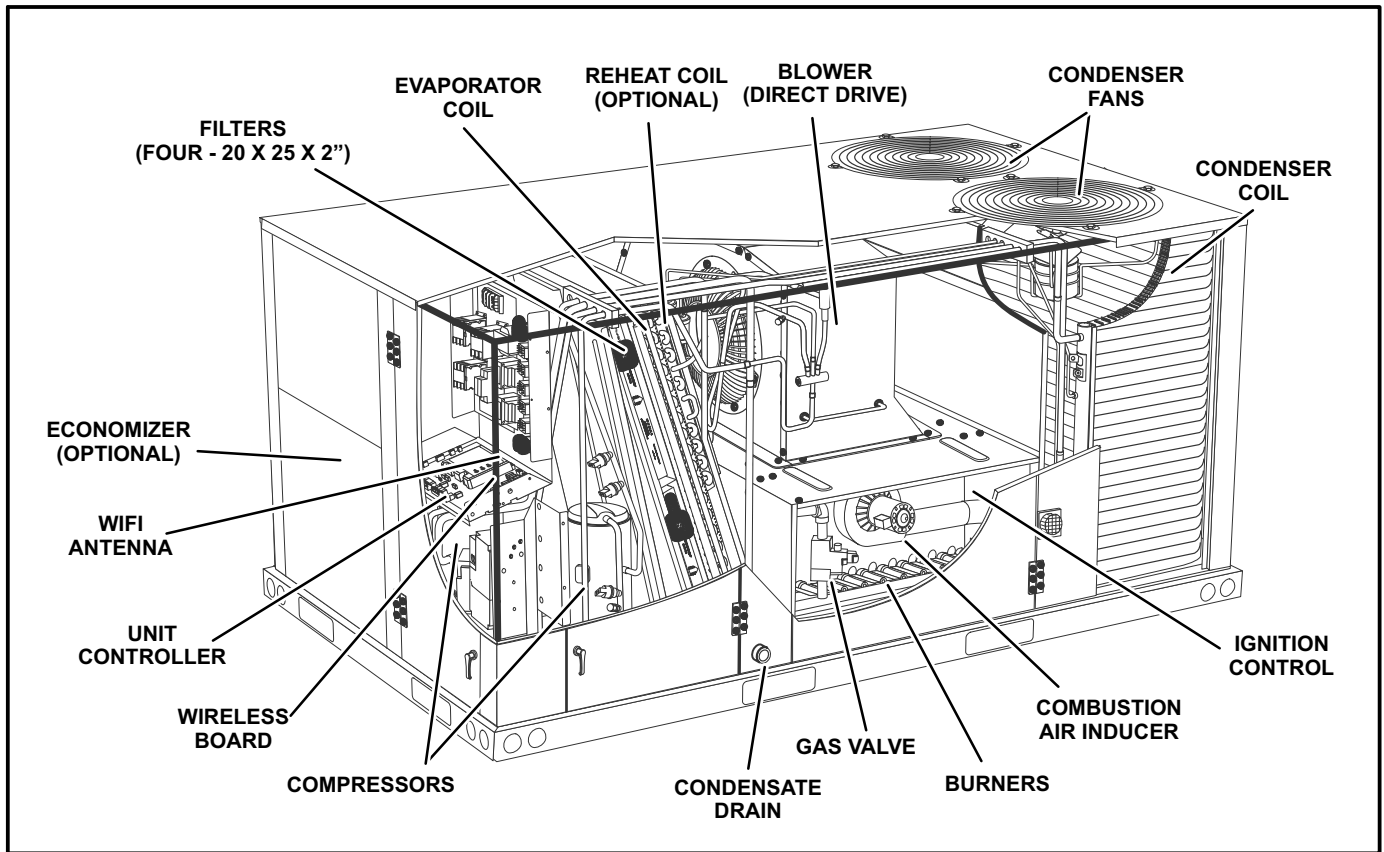

**LCT092, 102, 120, 150 PARTS ARRANGEMENT**

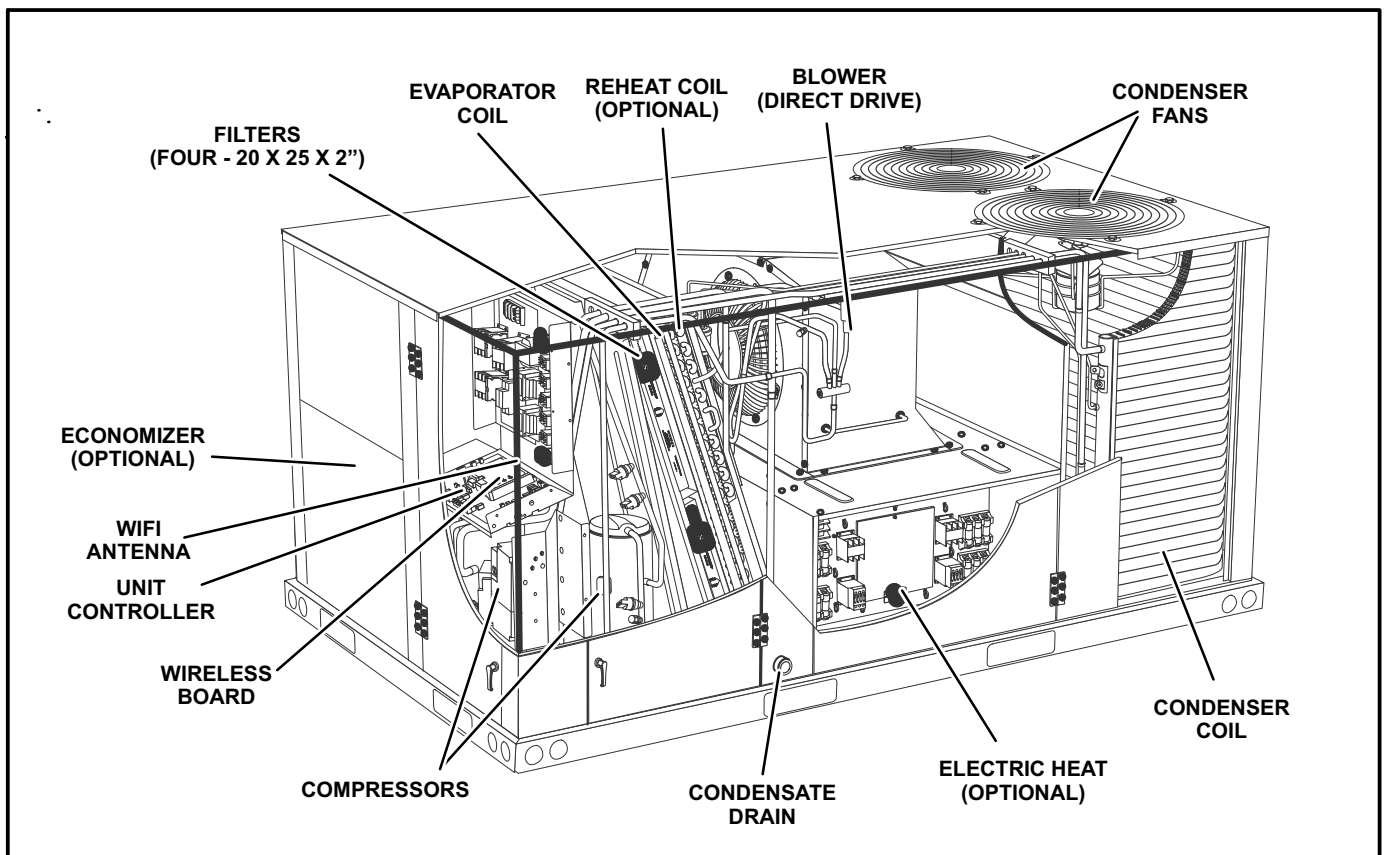

## Shipping and Packing List

**Package 1 of 1 contains:**

1- Assembled unit  
 Check unit for shipping damage. Receiving party should contact last carrier immediately if shipping damage is found.

## General

These instructions are intended as a general guide and do not supersede local codes in any way. Authorities having jurisdiction should be consulted before installation.

The LGT092H / 150H gas/electric packaged rooftop unit is available in 130,000, 180,000, or 240,000 Btuh heating inputs. The LCT092H / 150H cooling packaged rooftop unit is the same basic design as the LGT unit except for the heating section. Optional electric heat is factory- or field-installed in LCT units.

Units are equipped with all-aluminum condenser coils. Units are available with an optional hot gas reheat coil which provides dehumidifying modes of operation. Refer to Reheat Operation section.

Units are equipped with direct drive blowers. The blower will operate at lower speeds when demand is low and increase to higher speeds when demand is high. Refer to the Direct Drive Start-Up section.

The following examples show the model numbers of ten ton units with blower options.

- LGT/LCT120H4E      Single Zone MSAV Direct Drive
- LGT/LCT120H4P      VAV Direct Drive

All units are available using R410A, an ozone-friendly HFC refrigerant. Refer to the Cooling Start-Up section for precautions when installing unit.

## Safety

See table 1 for unit clearances.

⚠ WARNING



**Electric shock hazard and danger of explosion. Can cause injury, death or product or property damage. Turn off gas and electrical power to unit before performing any maintenance or servicing operations on the unit. Follow lighting instructions attached to unit when putting unit back into operation and after service or maintenance.**

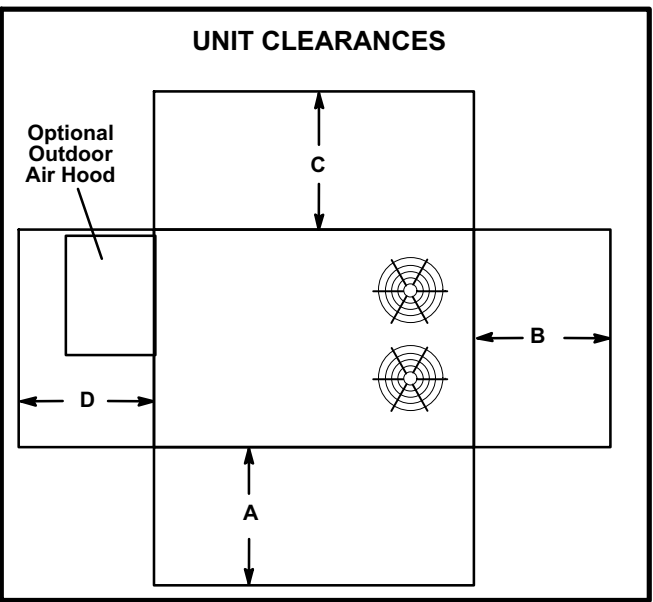

**FIGURE 1**

**TABLE 1  
UNIT CLEARANCES**

<sup>1</sup> Unit Clearance	A in.(mm)	B in.(mm)	C in.(mm)	D in.(mm)	Top Clearance
Service Clearance	60 (1524)	36 (914)	36 (914)	60 (1524)	Unob- structed
Clearance to Combustibles	36 (914)	1 (25)	1 (25)	1 (25)	Unob- structed
Minimum Operation Clearance	36 (914)	36 (914)	36 (914)	36 (914)	Unob- structed

Note - Entire perimeter of unit base requires support when elevated above mounting surface.

- <sup>1</sup> **Service Clearance** - Required for removal of serviceable parts.
- Clearance to Combustibles** - Required clearance to combustible material (gas units). On LCT units, see clearance to combustible materials as outlined on heater rating plate.
- Minimum Operation Clearance** - Required clearance for proper unit operation.

⚠ NOTICE

**Roof Damage!**  
 This system contains both refrigerant and oil. Some rubber roofing material may absorb oil, causing the rubber to swell. Bubbles in the rubber roofing material can cause leaks. Protect the roof surface to avoid exposure to refrigerant and oil during service and installation. Failure to follow this notice could result in damage to roof surface.

⚠ IMPORTANT

The Clean Air Act of 1990 bans the intentional venting of refrigerant (CFC's and HCFC's) as of July 1, 1992. Approved methods of recovery, recycling or reclaiming must be followed. Fines and/or incarceration may be levied for non-compliance.

Use of this unit as a construction heater or air conditioner is not recommended during any phase of construction. Very low return air temperatures, harmful vapors and operation of the unit with clogged or misplaced filters will damage the unit.

If this unit has been used for heating or cooling of buildings or structures under construction, the following conditions must be met or the warranty will be void:

- A room thermostat or zone air temperature sensor must control the unit. The use of fixed jumpers that will provide continuous heating or cooling is not allowed.
- A pre-filter must be installed at the entry to the return air duct.
- The return air duct must be provided and sealed to the unit.
- Return air temperature range between 55°F (13°C) and 80°F (27°C) must be maintained.
- Air filters must be replaced and pre-filters must be removed upon construction completion.
- The input rate and temperature rise must be set per the unit rating plate.
- The heat exchanger, components, duct system, air filters and evaporator coil must be thoroughly cleaned following final construction clean-up.
- The unit operating conditions (including airflow, cooling operation, ignition, input rate, temperature rise and venting) must be verified according to these installation instructions.

This appliance is not to be used by persons with reduced physical, sensory or mental capabilities, or lack of experience and knowledge, unless they have been given supervision or instruction.

This appliance should not be used by children. Children should be supervised to ensure they do not play with the appliance.

### **Unit Support**

In downflow discharge installations, install the unit on a non-combustible surface only. Unit may be installed on combustible surfaces when used in horizontal discharge applications or in downflow discharge applications when installed on an C1CURB7\*B roof mounting frame.

*NOTE - Securely fasten roof frame to roof per local codes.*

## **⚠ CAUTION**

**To reduce the likelihood of supply / return air bypass and promote a proper seal with the RTU, duct work / duct drops / diffuser assemblies must be supported independently to the building structure.**

**A-Downflow Discharge Application**

### **Roof Mounting with C1CURB7\*B**

- 1- The C1CURB7\*B roof mounting frame must be installed, flashed and sealed in accordance with the instructions provided with the frame.
- 2- The C1CURB7\*B roof mounting frame should be square and level to 1/16" per linear foot (5mm per linear meter) in any direction.
- 3- Duct must be attached to the roof mounting frame and not to the unit; supply and return plenums must be installed before setting the unit.

### **Installer's Roof Mounting Frame**

Many types of roof frames can be used to install the unit depending upon different roof structures. Items to keep in mind when using the building frame or supports are:

- 1- The base is fully enclosed and insulated, so an enclosed frame is not required.
- 2- The frames or supports must be constructed with non-combustible materials and should be square and level to 1/16" per linear foot (5mm per linear meter) in any direction.
- 3- Frame or supports must be high enough to prevent any form of moisture from entering unit. Recommended minimum frame height is 14" (356mm).
- 4- Duct must be attached to the roof mounting frame and not to the unit. Supply and return plenums must be installed before setting the unit.
- 5- Units require support along all four sides of unit base. Supports must be constructed of steel or suitably treated wood materials.

*NOTE-When installing a unit on a combustible surface for downflow discharge applications, an C1CURB7\*B roof mounting frame is required.*

## B-Horizontal Discharge Applications

- 1- Units installed in horizontal airflow applications must use a horizontal conversion kit K1HECK00.
- 2- Specified installation clearances must be maintained when installing units. Refer to figure 1.
- 3- Top of support slab should be approximately 4" (102mm) above the finished grade and located so no run-off water from higher ground can collect around the unit.
- 4- Units require support along all four sides of unit base. Supports must be constructed of steel or suitably treated wood materials.

### Duct Connection

All exterior ducts, joints and openings in roof or building walls must be insulated and weather-proofed with flashing and sealing compounds in accordance with applicable codes. Any duct passing through an unconditioned space must be insulated.

## CAUTION

**In downflow applications, do not drill or punch holes in base of unit. Leaking in roof may occur if unit base is punctured.**

### Rigging Unit For Lifting

Rig unit for lifting by attaching four cables to holes in unit base rail. See figure 2.

- 1- Detach wooden base protection before rigging.  
*Note - Remove all 7 (5 brackets on units with three outdoor fans) base protection brackets before setting unit.*
- 2- Connect rigging to the unit base using both holes in each corner.
- 3- All panels must be in place for rigging.
- 4- Place field-provided H-style pick in place just above top edge of unit. Frame must be of adequate strength and length. (H-style pick prevents damage to unit.)

### Condensate Drains

Make drain connection to the 1" N.P.T. drain coupling provided on unit.

*Note - The drain pan is made with a glass reinforced engineered plastic capable of withstanding typical joint torque but can be damaged with excessive force. Tighten pipe nipple hand tight and turn an additional quarter turn.*

A trap must be installed between drain connection and an open vent for proper condensate removal. See figure 3 or 4. It is sometimes acceptable to drain condensate onto the roof or grade; however, a tee should be fitted to the trap to direct condensate downward. The condensate line must be vented. Check local codes concerning condensate disposal. Refer to pages 1 and 2 for condensate drain location.

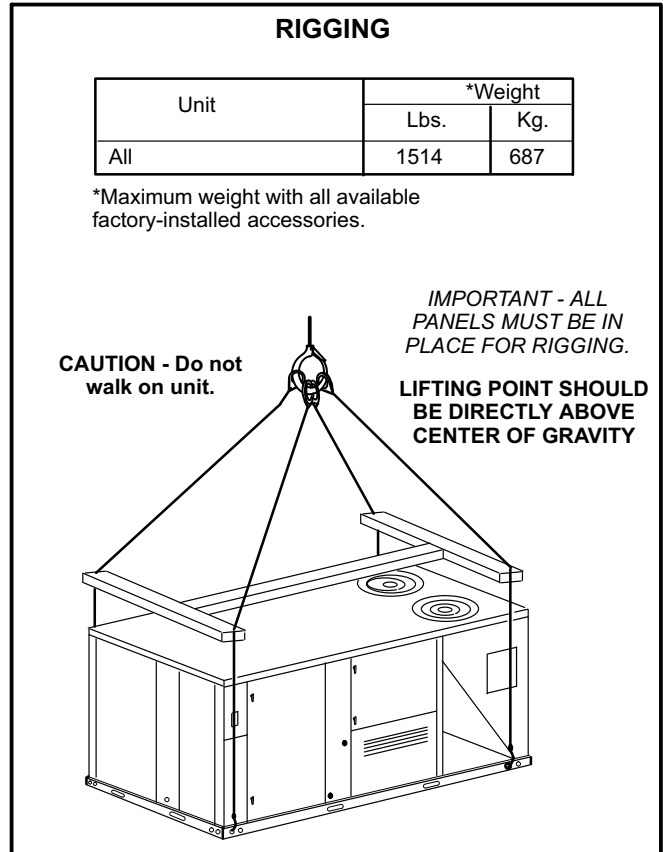

**FIGURE 2**

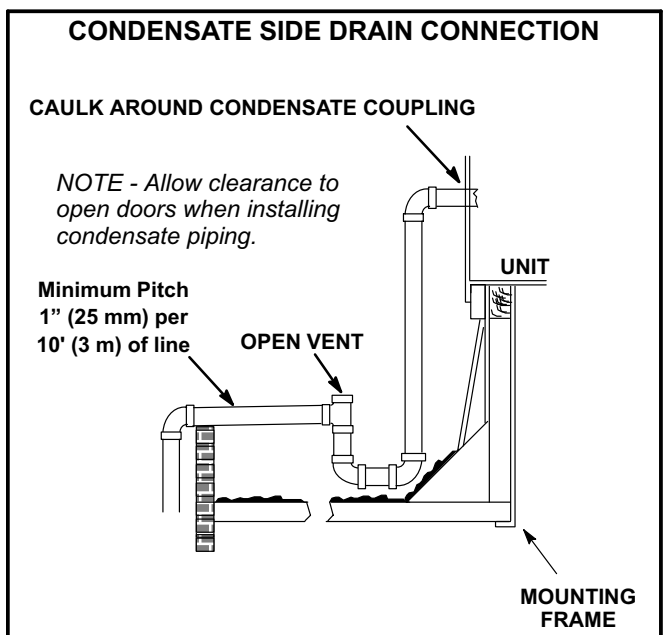

**FIGURE 3**

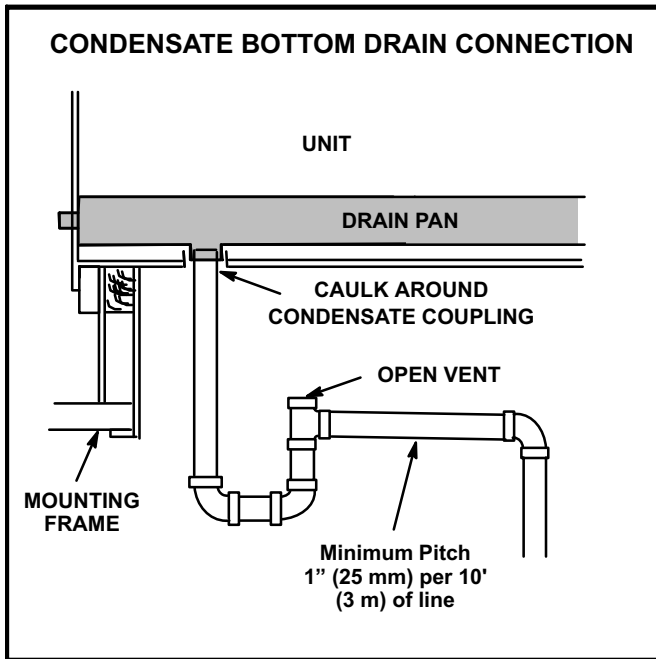
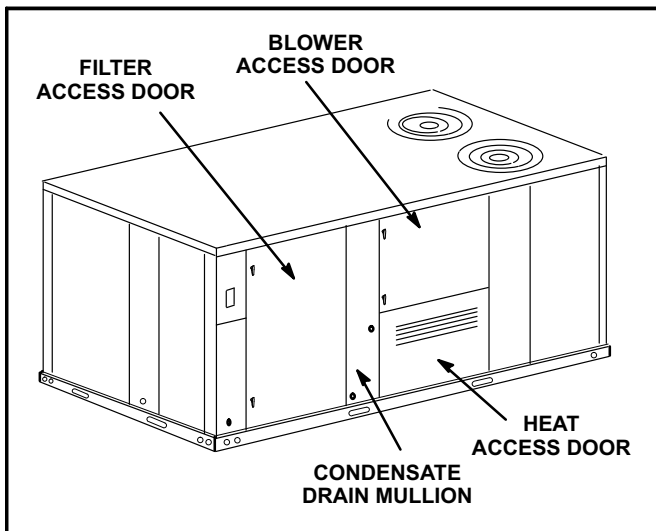

**FIGURE 4**

Units are shipped with the drain coupling facing the front of the unit. Condensate can be drained from the back or bottom of the unit with the following modifications. The unit can be installed in either downflow or horizontal air discharge regardless of condensate drain location.

**Rear Drain Connection**

1- Open blower and heat access doors. See figure 5.



**FIGURE 5**

2- Remove six screws from filter access door. Refer to figure 6.

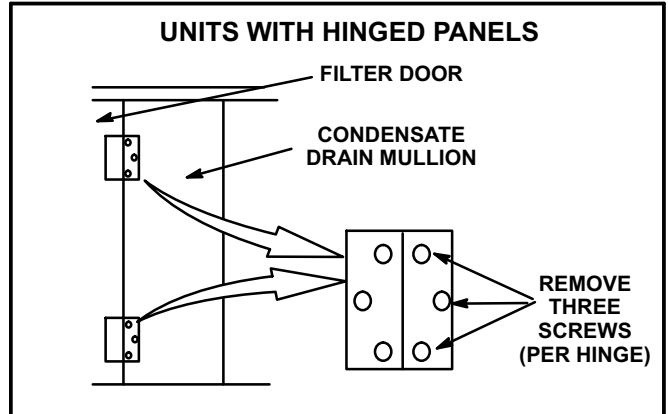

**FIGURE 6**

- 3- Open filter access door hinges and carefully remove door.
- 4- Remove eight screws holding condensate drain mullion and remove mullion.
- 5- Lift front edge of the drain pan (to clear bottom drain plug) and slide drain pan out of unit. See figure 7.

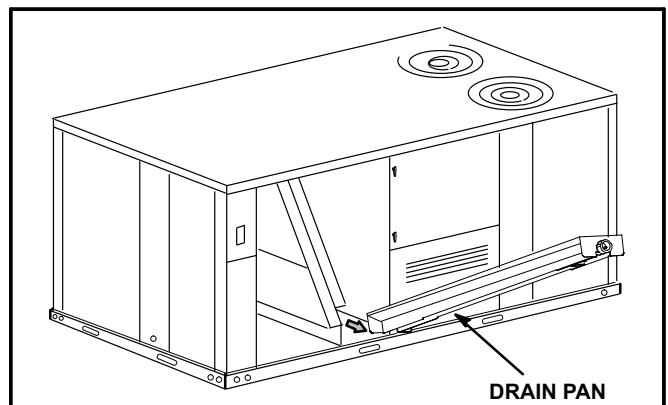
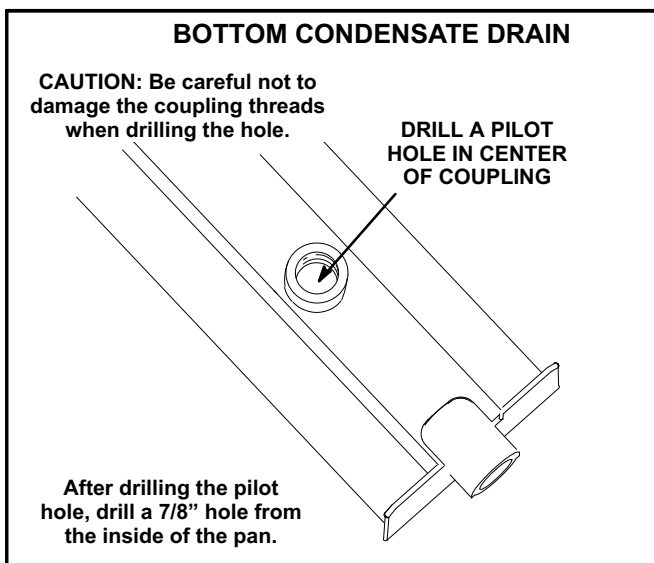

**FIGURE 7**

- 6- Make sure the cap over the unit bottom drain hole is secure.
- 7- Rotate the drain pan until the downward slope is toward the back of the unit. Slide the drain pan back into the unit. Be careful not to dislodge the cap over the bottom drain hole.
- 8- From the back side of the unit, pull the drain pan coupling through the rear condensate opening.
- 9- Replace the condensate drain mullion and reinstall eight screws.
- 10- Reinstall filter door on hinges.

## Bottom Drain Connection

- 1- Open blower and heat access doors. See figure 5.
- 2- Remove six screws from filter access door. Refer to figure 6.
- 3- Open filter access door hinges and carefully remove door.
- 4- Remove eight screws holding condensate drain mullion and remove mullion.
- 5- Lift front edge of the drain pan (to clear bottom drain plug) and slide drain pan out of unit. See figure 7.
- 6- Turn the drain pan upside down and drill a pilot hole through the bottom of the drain pan in the center of the coupling. See figure 8.



**FIGURE 8**

- 7- From the inside of the pan, use a Vari-Bit® bit to enlarge the hole to 7/8". Do not damage coupling threads.
- 8- Remove the cap over the unit bottom drain hole.
- 9- Slide the drain pan back into the unit.
- 10- From the back side of the unit, pull the drain pan coupling through the rear condensate opening.
- 11- From the front side of the unit, move the drain pan until the bottom coupling settles into the unit bottom drain opening. Once in place, check to make sure the coupling is still positioned through the rear condensate drain hole.
- 12- Use a field-provided 1" plug to seal side drain connection.
- 13- Replace the condensate drain mullion and reinstall eight screws.
- 14- Reinstall filter door on hinges.

## Connect Gas Piping (Gas Units)

Before connecting piping, check with gas company or authorities having jurisdiction for local code requirements. When installing gas supply piping, length of run from gas meter must be considered in determining pipe size for 0.5" w.c. (.12kPa) maximum pressure drop. Do not use supply pipe smaller than unit gas connection. For natural gas units, operating pressure at the unit gas connection must be a minimum of 4.7" w.c. (1.17kPa) and a maximum of 10.5" (2.60kPa) w.c. For LP/propane gas units, operating pressure at the unit gas connection must be a minimum of 10.5" w.c. (2.61kPa) and a maximum of 13.0" w.c. (3.23kPa).

When making piping connections a drip leg should be installed on vertical pipe runs to serve as a trap for sediment or condensate. A 1/8" N.P.T. plugged tap is located on gas valve for test gauge connection. Refer to Heating Start-Up section for tap location. Install a ground joint union between the gas control manifold and the main manual shut-off valve. See figure 9 for gas supply piping entering outside the unit. Figure 10 shows bottom gas entry piping through the curb. Figure 11 shows bottom gas entry piping through the unit.

Compounds used on threaded joints of gas piping shall be resistant to the action of liquified petroleum gases.

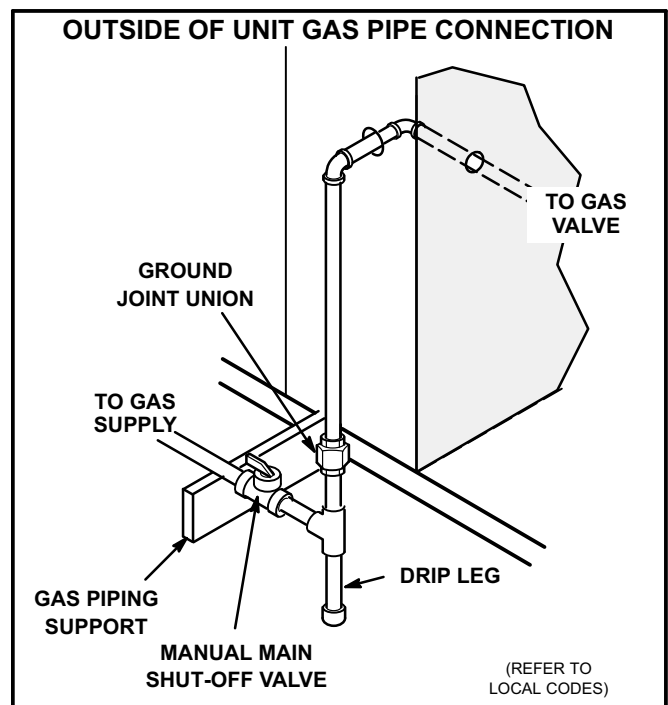

**FIGURE 9**



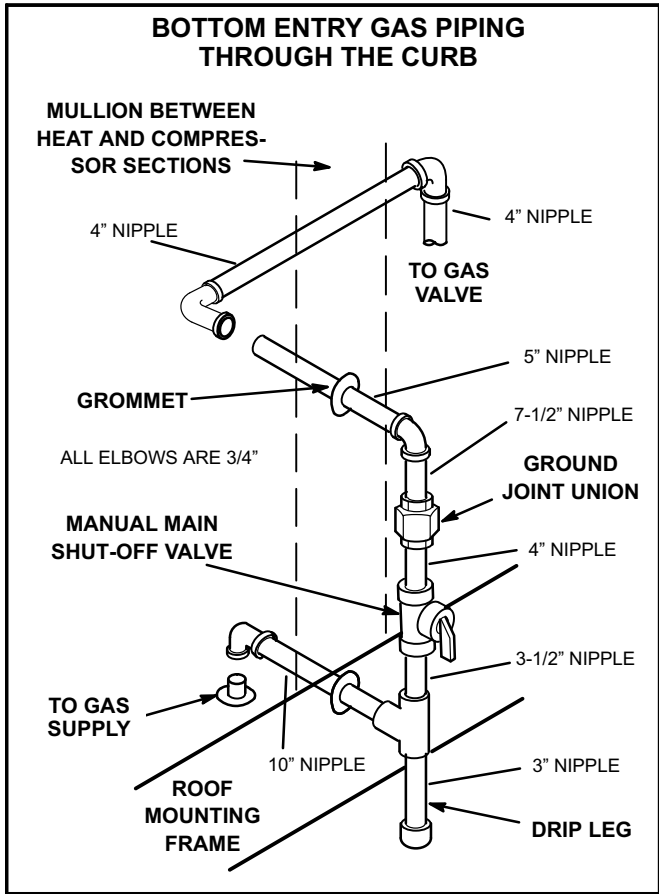

FIGURE 10

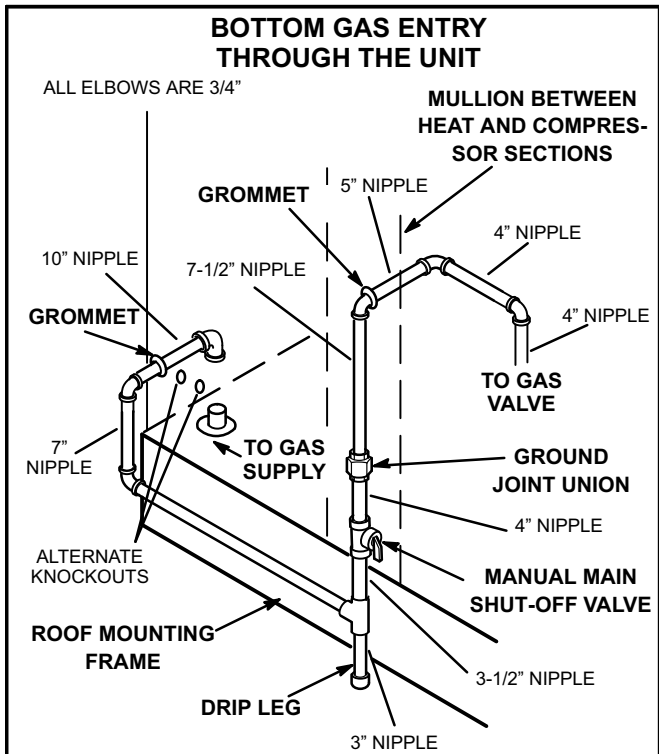

FIGURE 11

**Pressure Test Gas Piping (Gas Units)**

When pressure testing gas lines, the gas valve must be disconnected and isolated. Gas valves can be damaged if subjected to more than 0.5 psig (3.48kPa). See figure 12.

*NOTE-Codes may require that manual main shut-off valve and union (furnished by installer) be installed in gas line external to unit. Union must be of the ground joint type.*

After all connections have been made, check all piping connections for gas leaks. Also check existing unit gas connections up to the gas valve; loosening may occur during installation. Use a leak detection solution or other preferred means. Do not use matches candles or other sources of ignition to check for gas leaks.

*NOTE-In case emergency shut down is required, turn off the main manual shut-off valve and disconnect main power to unit. These devices should be properly labeled by the installer.*

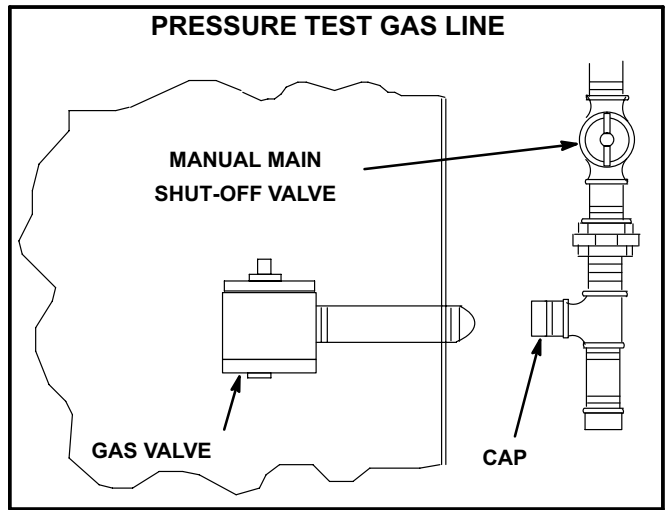

FIGURE 12

**⚠ CAUTION**  
Some soaps used for leak detection are corrosive to certain metals. Carefully rinse piping thoroughly after leak test has been completed. Do not use matches, candles, flame or other sources of ignition to check for gas leaks.

**⚠ WARNING**  
Danger of explosion. Can cause injury or product or property damage. Do not use matches, candles, flame or other sources of ignition to check for leaks.

## High Altitude Derate

Locate the high altitude conversion sticker in the unit literature bag. Fill out the conversion sticker and affix next to the unit nameplate. High altitude kits are available for field-installation.

Refer to table 2 for high altitude adjustments.

**TABLE 2  
HIGH ALTITUDE DERATE**

Unit (KBtuh)	Altitude Ft.*	Gas Manifold Pressure
All	2000-4500	See Unit Nameplate
130-180	4500 And Above	Derate 2% / 1000 Ft. Above Sea Level
240	4500 And Above	Derate 4% / 1000 Ft. Above Sea Level

\*Units installed at 0-2000 feet do not need to be modified.

*NOTE - This is the only permissible derate for these units.*

## Download Mobile Service App

### A-Mobile Device Requirements

- Android hardware requires 2GB RAM and a 2Ghz core processor. Tablets are supported.
- Minimum Android 6.0 (Marshmallow) or higher. Recommend Android 10 and Apple products require iOS version 11 or higher.

### B-New Installations

Once the app is downloaded, refer to the Setup Guide provided with this unit to pair the app to the unit control system. Follow the setup wizard prompts to configure the unit. See figure 13 for the app menu overview. If a mobile device is unavailable or not pairing, refer to the Unit Controller Setup Guide for start-up instructions.

## Electrical Connections - Power Supply

Route field wiring in conduit between bottom power entry disconnect. See figure 14. This does not supersede local codes or authorities having jurisdiction.

Do not apply power or close disconnect switch until installation is complete. Refer to start-up directions. Refer closely to unit wiring diagram.

Refer to unit nameplate for minimum circuit ampacity and maximum fuse size.

- 1- 230/460/575 volt units are factory wired. **For 208V supply**, disconnect the orange wire (230V) at all control power transformer(s). Reconnect the red wire (208V). Tape the exposed end of the 230V orange wire.
- 2- Route power through the bottom power entry area. On gas units or units with electric heat, connect power wiring to TB2. On cooling only units, connect power to F4. If unit contains an optional factory-installed circuit breaker or disconnect switch, connect line voltage to CB10 or S48. See unit wiring diagram.

- 3- Connect separate 120v wiring to optional field-powered GFCI outlet. Route field wiring in conduit between bottom power entry and GFCI. See figure 14. For unit-powered GFCI, no additional field wiring is required.

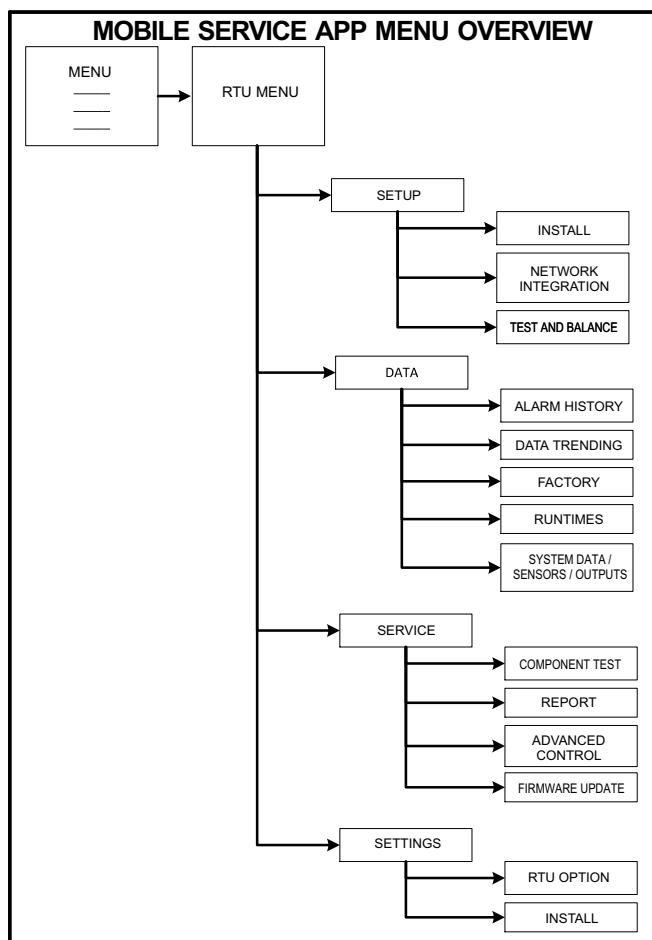

FIGURE 13

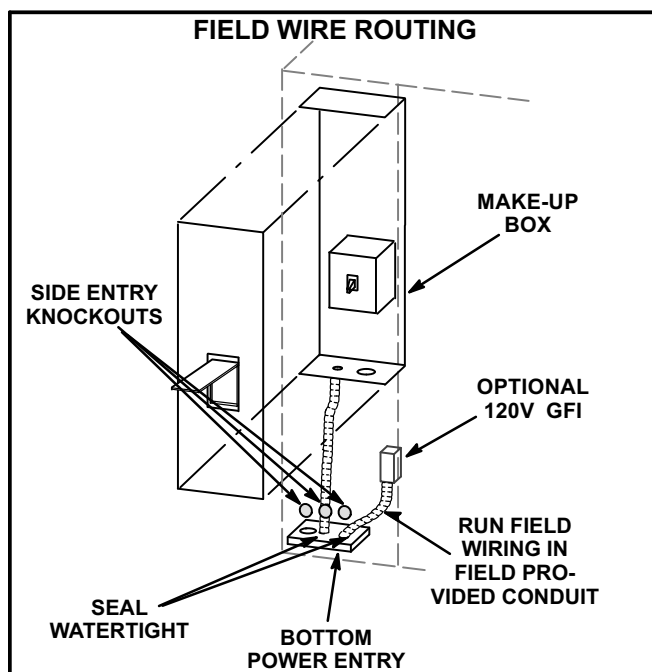

FIGURE 14

## Electrical Connections - Control Wiring

*NOTE - Optional wireless sensors are available for use with this unit. Refer to the instructions provided with each sensor.*

### ⚠ CAUTION

**Electrostatic discharge can affect electronic components. Take precautions during unit installation and service to protect the electronic controls. Precautions will help to avoid control exposure to electrostatic discharge by putting the unit, the control and the technician at the same electrostatic potential. Neutralize electrostatic charge by touching hands and all tools on an unpainted unit surface, such as the gas valve or blower deck, before performing any service procedure.**

#### A-Thermostat Location

Applied to units in default thermostat control mode only. Room thermostat mounts vertically on a standard 2" X 4" handy box or on any non-conductive flat surface.

Locate thermostat approximately 5 feet (1524mm) above the floor in an area with good air circulation at average temperature. Avoid locating the room thermostat where it might be affected by:

- drafts or dead spots behind doors and in corners
- hot or cold air from ducts
- radiant heat from sun or appliances
- concealed pipes and chimneys

#### B-Control Wiring

The Unit Controller will operate the unit from a thermostat or zone sensor based on the System Mode. The default System Mode is the thermostat mode. Refer to the Unit Controller Setup Guide to change the System Mode. Use the mobile service app menu and select *Settings > Install*.

##### Thermostat Mode

- 1- Route thermostat cable or wires from subbase to control area above compressor (refer to unit dimensions to locate bottom and side power entry).

**IMPORTANT - Unless field thermostat wires are rated for maximum unit voltage, they must be routed away from line voltage wiring. Use wire ties located near the lower left corner of the controls mounting panel to secure thermostat cable.**

Use 18 AWG wire for all applications using remotely installed electro-mechanical and electronic thermostats.

- 2- Install thermostat assembly in accordance with instructions provided with thermostat.

- 3- Connect thermostat wiring to Unit Controller on the lower side of the controls hat section.
- 4- Wire as shown in figure 15 for electro-mechanical and electronic thermostats. If using other temperature control devices or energy management systems see instructions and wiring diagram provided by manufacturer.

**IMPORTANT - Terminal connections at the Unit Controller must be made securely. Loose control wire connections may allow unit to operate but not with proper response to room demand.**

##### Zone Sensor Mode

The Unit Controller will operate heating and cooling based on the Unit Controller internal setpoints and the temperature from the A2 room sensor. An optional Network Control Panel (NCP) can also be used to provide setpoints. A thermostat or return air sensor can be used as a back-up mode. Make room sensor wiring connections as shown in figure 16.

##### C-Hot Gas Reheat Units Only -

- 1- Install humidity sensor in accordance with instructions provided with sensor. A DDC input may be used to initiate dehumidification instead of a sensor.
- 2- Make wiring connections as shown in figure 15 for Thermostat Mode or figure 16 for Zone Sensor Mode. In addition, connect either a humidity sensor or a dehumidification input. See figure 18 or 19 for humidity sensor wiring or figure 17 for dehumidification input wiring.

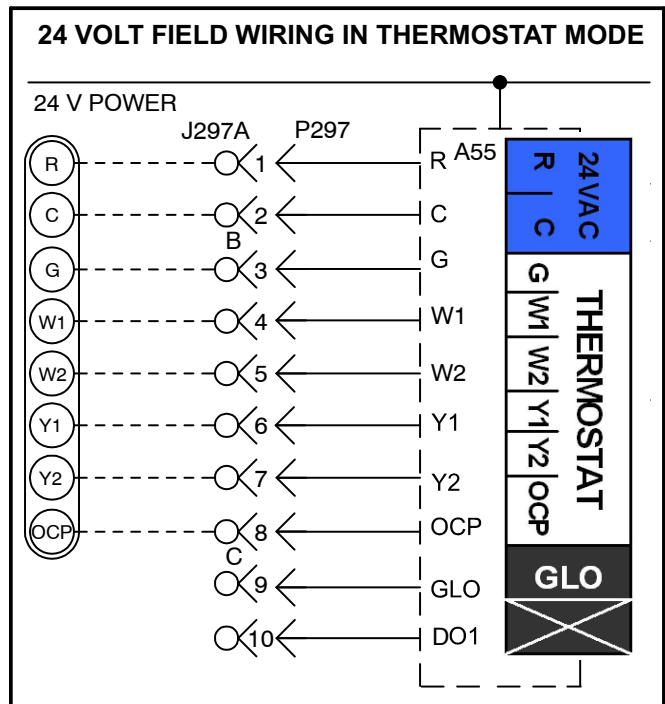

**FIGURE 15**

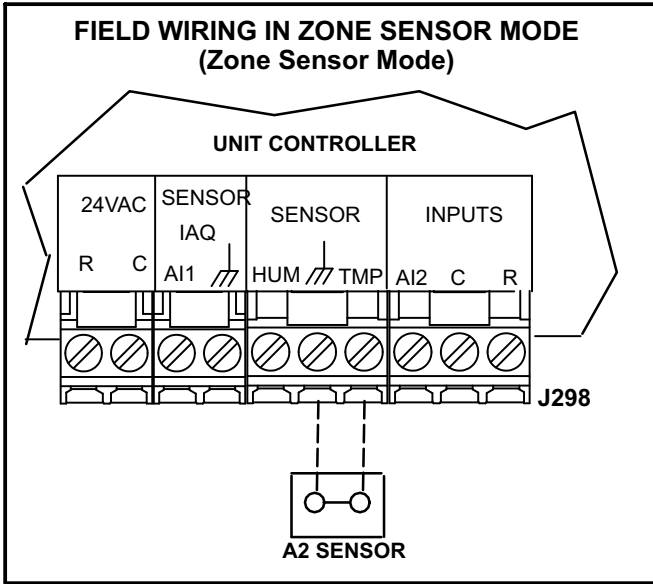

**FIGURE 16**

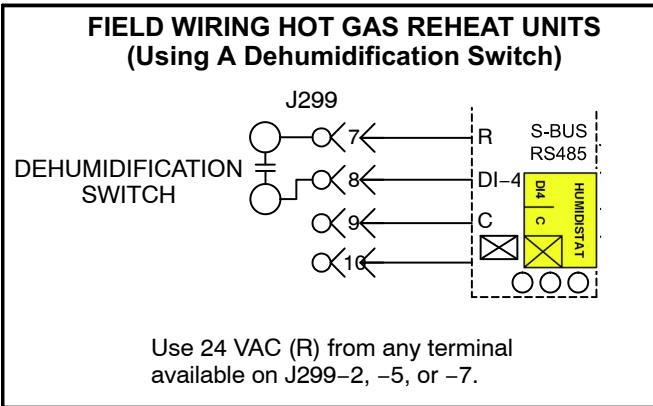

**FIGURE 17**

Humidity Sensor Cable Applications:

**Wire runs of 50 feet (mm) or less:**

Use two separate shielded cables containing 20AWG minimum, twisted pair conductors with overall shield. Belden type 8762 or 88760 (plenum) or equivalent. Connect both cable shield drain wires to the Unit Controller as shown in figure 18.

**Wire runs of 150 feet (mm) or less:**

Use two separate shielded cables containing 18AWG minimum, twisted pair conductors with overall shield. Belden type 8760 or 88760 (plenum) or equivalent. Connect both cable shield drain wires to the Unit Controller as shown in figure 18.

**Wire runs over 150 feet (mm):**

Use a local, isolated 24VAC transformer such as Lennox cat #18M13 (20VA minimum) to supply power to RH sensor as shown in figure 19. Use two shielded cables containing 20AWG minimum, twisted pair conductors with overall shield. Belden type 8762 or 88760 (plenum) or equivalent.

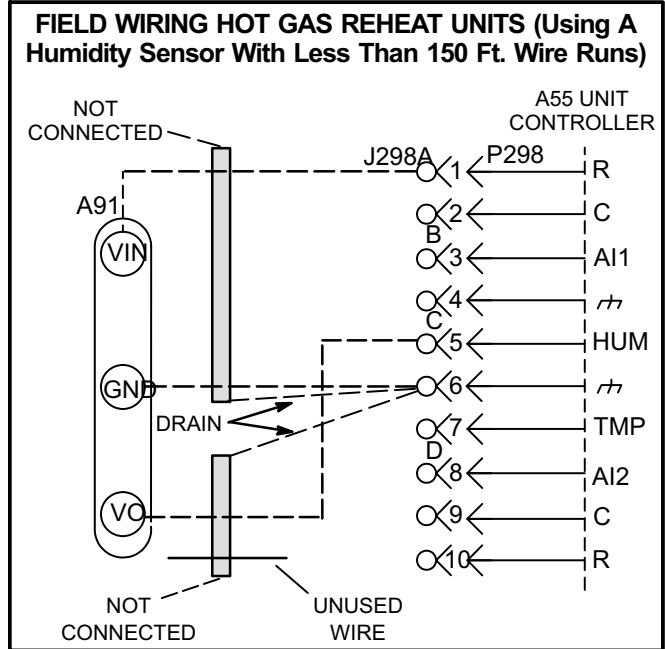

**FIGURE 18**

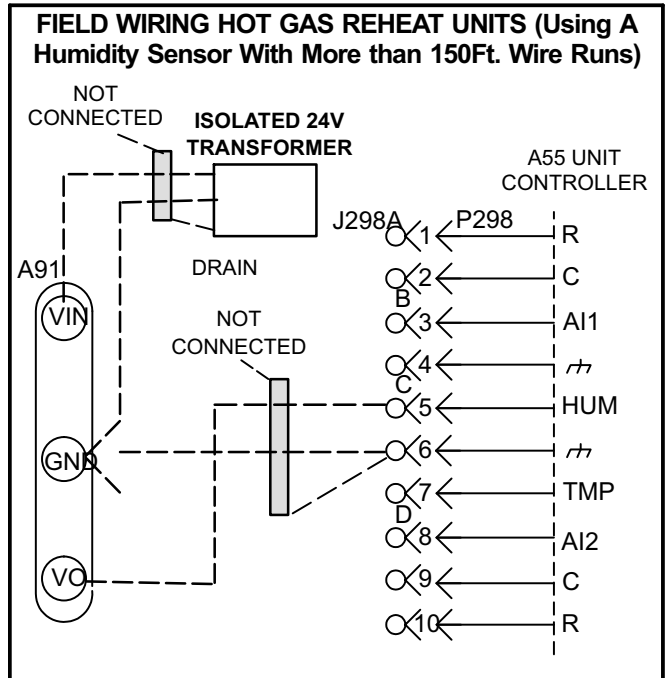

**FIGURE 19**

## Blower Operation

Units are equipped with variable speed, direct drive blowers. The installer is able to enter the design-specified supply air CFM into the Unit Controller for optimal efficiency. The Unit Controller calibrates the supply air volume which eliminates the need to manually take duct static measurements. Refer to *C-Adjusting Unit CFM - Ultra High Efficiency Direct Drive Blowers*.

### ⚠ IMPORTANT

Compressor two is the only component that must be checked to ensure proper phasing. Follow "COOLING START-UP" section of installation instructions to ensure proper compressor and blower operation.

The Unit Controller checks the incoming power during start-up. If the voltage or phase is incorrect, the Unit Controller will display an alarm and the unit will not start.

#### A-Blower Operation

Refer to the Unit Controller Setup Guide to energize blower. Use the mobile service app menu; see *SERVICE > TEST*.

In thermostat control mode, the Unit Controller will stage the blower between low and high speed. In zone sensor control mode, the Unit Controller will vary (VAV) the blower between low and high speed.

### ⚠ WARNING

1-Make sure that unit is installed in accordance with the installation instructions and applicable codes.

2-Inspect all electrical wiring, both field- and factory-installed, for loose connections. Tighten as required.

3-Check to ensure that refrigerant lines do not rub against the cabinet or against other refrigerant lines.

4-Check voltage at disconnect switch. Voltage must be within range listed on nameplate. If not, consult power company and have voltage condition corrected before starting unit.

5-Make sure filters are new and in place before start-up.

Initiate blower only (G) demand at thermostat according to instructions provided with thermostat. Unit will cycle on thermostat demand. The following steps apply to applications using a typical electro-mechanical thermostat.

- 1- Blower operation is manually set at the thermostat subbase fan switch. With fan switch in **ON** position, blowers will operate continuously.
- 2- With fan switch in **AUTO** position, the blowers will cycle with demand. Blowers and entire unit will be off when system switch is in **OFF** position.

*NOTE - Blower operation mode can also be initiated by the mobile service app.*

Direct-drive motor may not immediately stop when power is interrupted to the Unit Controller. Disconnect unit power before opening the blower compartment. The Controller's digital inputs must be used to shut down the blower. See Unit Controller manual for operation sequences.

#### B-Blower Access

The blower assembly is secured to a sliding frame which allows the blower assembly to be pulled out of the unit. See figure 21.

- 1- Loosen the reusable wire tie which secures the controls and high voltage blower wiring to the blower housing. Disconnect the pressure sensor low voltage wire harness.
- 2- Remove and retain screws on either side (and on the front for direct drive) of sliding frame. Use the metal handle to pull frame toward outside of unit.
- 3- Slide frame back into original position when finished servicing. Reattach the blower wiring in the previous location using the wire tie. Reconnect pressure sensor low voltage wire harness.
- 4- Replace retained screws.

**LOCATION OF STATIC PRESSURE READINGS**

**INSTALLATIONS WITH DUCTWORK**

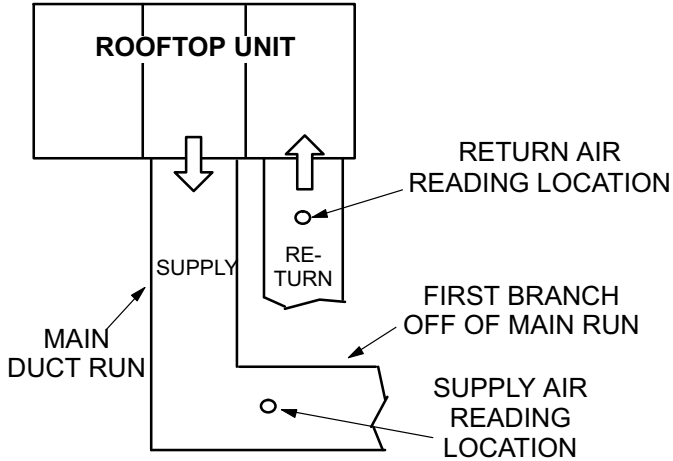

**INSTALLATIONS WITH CEILING DIFFUSERS**

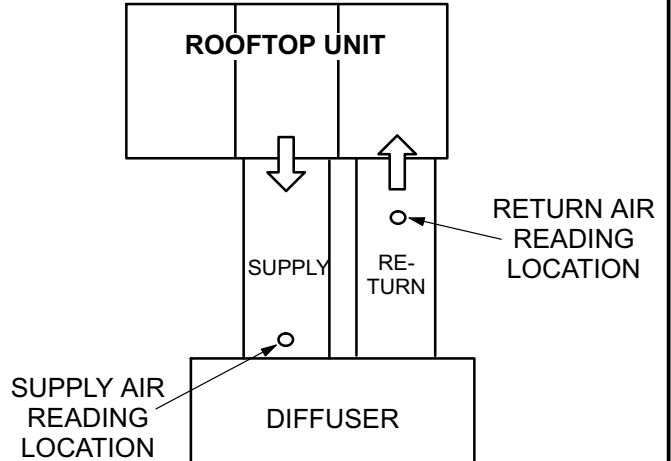

**FIGURE 20**

**DIRECT DRIVE BLOWER ASSEMBLY**

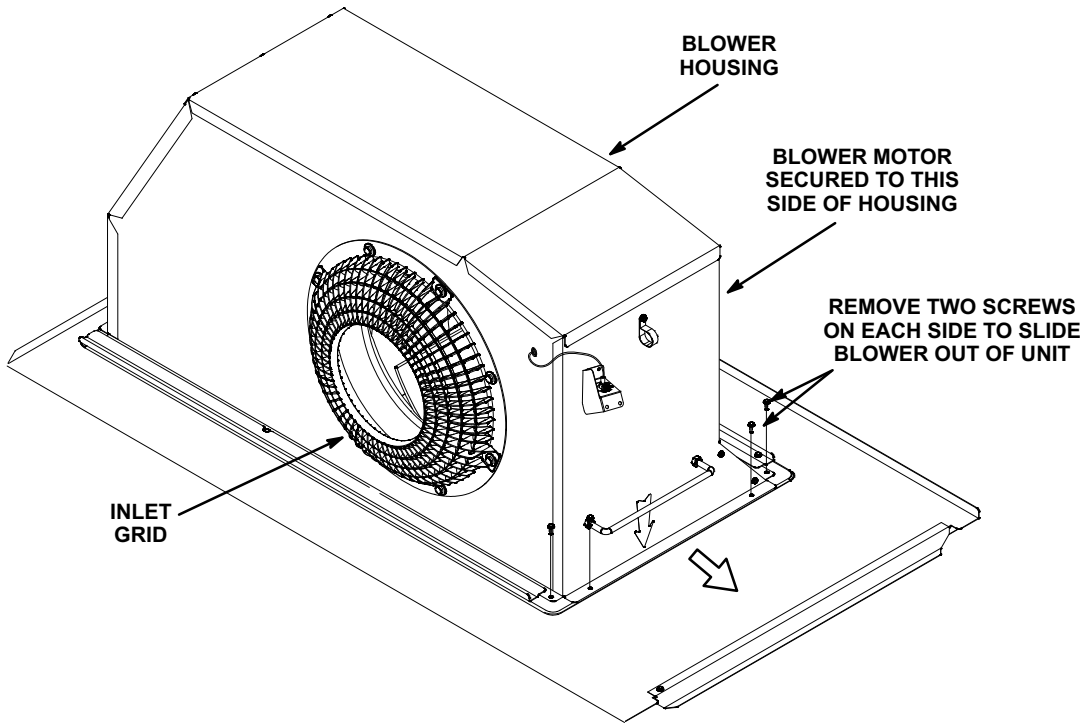

**FIGURE 21**

## Direct Drive Blower Start-Up

The supply CFM can be adjusted by changing the percentage of motor output using the Unit Controller settings. Refer to table 3 for menu paths and default settings. Record any RPM% changes on the parameter settings label located on the inside of the compressor access panel.

### CAUTION

The BLOWER CALIBRATION process starts the indoor blower at operational speeds and moves the economizer damper blades. Before starting this process, replace any access panels and close all unit doors except compressor compartment door.

Blower calibration is required only on units that are newly installed or if there is a change in the duct work or air filters after installation. Use the mobile service app to navigate to the SETUP>TEST & BALANCE>BLOWER menu. After the new RPM% values are entered, select START CALIBRATION. The blower calibration status is displayed as a % complete. Upon successful completion, the mobile service app will display CALIBRATION SUCCESS and go back to the blower calibration screen.

*IMPORTANT - The default value for Cooling Low motor speed is lower than a traditional single- or two-speed unit. If operating the unit with a 2- or 3-stage controller (2- or 3-stage thermostat, DDC controller, etc.), it is recommended to increase the Cooling Low CFM default value to a suitable level for part load cooling (typically 60% of full load CFM).*

**TABLE 3  
DIRECT DRIVE PARAMETER SETTINGS - 581102-01**

Parameter	Field Setting	Description
<b>Note: Any changes to Smoke CFM setting must be adjusted before the other CFM settings. Use SETTINGS &gt; RTU OPTIONS &gt; EDIT PARAMETERS = 12 for EBM, 6 for ECM</b>		
BLOWER SMOKE CFM	%	Percentage of RPM for blower smoke speed.
<b>SETUP &gt; TEST &amp; BALANCE &gt; BLOWER</b>		
BLOWER HEATING HIGH CFM	%	Percentage of RPM for blower heating high speed.
BLOWER HEATING LOW CFM	%	Percentage of RPM for blower heating low speed (P volt gas heat only).
BLOWER COOLING HIGH CFM	%	Percentage of RPM for blower cooling high speed.
BLOWER COOLING LOW CFM	%	Percentage of RPM for blower cooling low speed and vent speed for standard static blowers.
BLOWER VENTILATION CFM	%	Percentage of RPM for high static blower ventilation speed.
<b>SETUP &gt; TEST &amp; BALANCE &gt; DAMPER</b>		
BLOWER HIGH CFM DAMPER POS %	%	Minimum damper position for high speed blower operation. Default 0%.
BLOWER LOW CFM DAMPER POS %	%	Minimum damper position for low speed blower operation. Default 0%.
POWER EXHAUST DAMPER POS %	%	Minimum damper position for low power exhaust operation. Default 50%.
<b>SETTINGS &gt; RTU OPTIONS &gt; EDIT PARAMETERS = 216</b>		
POWER EXHAUST DEADBAND %	%	Deadband % for power exhaust operation. Default 10%.
<b>SETTINGS &gt; RTU OPTIONS &gt; EDIT PARAMETERS = 10 (Applies to Thermostat Mode ONLY)</b>		
FREE COOLING STAGE-UP DELAY	sec	Number of seconds to hold blower at low speed before switching to blower at high speed. Default 300 seconds.

**Installer:** Record any parameter changes under "Field Setting" column. Settings need to be recorded by installer for use when Unit Controller is replaced or reprogrammed.

## BLOWER DATA

**BLOWER TABLE INCLUDES RESISTANCE FOR BASE UNIT ONLY (NO HEAT SECTION) WITH DRY INDOOR COIL AND AIR FILTERS IN PLACE.**

FOR ALL UNITS ADD:

- 1 - Wet indoor coil air resistance of selected unit.
  - 2 - Any factory installed options air resistance (heat section, Economizer, etc.)
  - 3 - Any field installed accessories air resistance (duct resistance, diffuser, etc.)
- See page 17 for wet coil and option/accessory air resistance data.  
See page 17 for minimum air volume required for use with optional electric heat.

**Maximum Static Pressure With Gas Heat - 2.0 in. w.g.**

**Minimum Air Volume Required For Different Gas Heat Sizes:**

Standard - 2150 cfm; Medium - 2250 cfm; High - 2600 cfm

Total Air Volume cfm	Total Static Pressure - in. w.g.													
	0.2		0.4		0.6		0.8		1.0		1.2		1.4	
	RPM	Watts	RPM	Watts	RPM	Watts	RPM	Watts	RPM	Watts	RPM	Watts	RPM	Watts
1750	759	223	864	298	961	359	1049	420	1128	508	1199	607	1260	704
2000	846	271	943	345	1035	410	1117	488	1189	598	1255	704	1313	804
2250	945	303	1030	391	1111	476	1184	577	1247	697	1310	806	1367	905
2500	1035	366	1109	476	1180	583	1245	688	1306	797	1368	903	1426	1008
2750	1113	476	1182	601	1248	715	1310	809	1371	902	1432	1011	1491	1129
3000	1195	596	1261	718	1324	827	1385	922	1444	1024	1503	1146	1559	1279
3250	1282	711	1346	827	1406	935	1464	1044	1521	1167	1576	1306	1629	1460
3500	1372	821	1432	940	1489	1060	1544	1192	1598	1337	1650	1494	1700	1663
3750	1461	949	1517	1081	1571	1221	1624	1373	1675	1532	1725	1700	1773	1875
4000	1549	1109	1602	1256	1653	1413	1703	1576	1753	1743	1801	1916	1847	2091
4250	1637	1298	1687	1458	1735	1625	1784	1795	1831	1966	1877	2139	1923	2310
4500	1724	1510	1772	1678	1818	1851	1864	2023	1910	2195	1955	2365	2000	2530
4750	1811	1738	1856	1910	1901	2083	1946	2254	1990	2423	2034	2587	2079	2746
5000	1897	1973	1941	2144	1985	2314	2028	2480	2071	2644	2114	2805	2158	2959
5250	1983	2205	2026	2373	2069	2538	2111	2699	2153	2860	2195	3017	---	---
5500	2070	2428	2112	2595	2153	2756	2194	2912	---	---	---	---	---	---
5750	2156	2643	2197	2809	---	---	---	---	---	---	---	---	---	---

Total Air Volume cfm	Total Static Pressure - in. w.g.											
	1.6		1.8		2.0		2.2		2.4		2.6	
	RPM	Watts	RPM	Watts	RPM	Watts	RPM	Watts	RPM	Watts	RPM	Watts
1750	1316	793	1373	875	1432	963	1491	1064	1548	1175	1604	1300
2000	1368	894	1425	982	1483	1081	1540	1196	1596	1322	1650	1458
2250	1423	1001	1480	1101	1537	1216	1593	1344	1647	1483	1700	1629
2500	1483	1117	1539	1236	1594	1368	1648	1509	1700	1657	1752	1810
2750	1547	1256	1601	1394	1654	1539	1705	1690	1756	1846	1806	2004
3000	1612	1425	1664	1577	1715	1734	1765	1893	1815	2053	1864	2213
3250	1680	1623	1729	1787	1778	1949	1828	2110	1876	2269	1925	2426
3500	1748	1835	1796	2003	1844	2165	1893	2324	1942	2479	1991	2633
3750	1819	2048	1866	2214	1914	2374	1963	2530	2012	2684	2061	2837
4000	1893	2260	1940	2423	1988	2581	2036	2737	2084	2891	2134	3044
4250	1969	2475	2016	2634	2063	2790	2111	2945	2159	3098	---	---
4500	2046	2689	2093	2844	2140	2998	2187	3153	---	---	---	---
4750	2124	2900	2170	3053	---	---	---	---	---	---	---	---
5000	2203	3111	---	---	---	---	---	---	---	---	---	---
5250	---	---	---	---	---	---	---	---	---	---	---	---
5500	---	---	---	---	---	---	---	---	---	---	---	---



## BLOWER DATA

### FACTORY INSTALLED OPTIONS/FIELD INSTALLED ACCESSORY AIR RESISTANCE - in. w.g.

Air Volume cfm	Wet Indoor Coil		Gas Heat Exchanger			Electric Heat	Econo mizer	Reheat Coil	Filters			Return Air Adaptor Plate
			Standard Heat	Medium Heat	High Heat				MERV 8	MERV 13	MERV 16	
	092, 102	120, 150										
1750	0.04	0.04	0.06	0.02	0.02	0.03	0.05	0.02	0.01	0.03	0.06	0.00
2000	0.05	0.05	0.07	0.05	0.06	0.03	0.06	0.02	0.01	0.03	0.08	0.00
2250	0.06	0.06	0.07	0.07	0.08	0.04	0.08	0.02	0.01	0.04	0.09	0.00
2500	0.07	0.07	0.09	0.10	0.11	0.04	0.11	0.03	0.01	0.05	0.10	0.00
2750	0.08	0.08	0.09	0.11	0.12	0.05	0.12	0.03	0.02	0.05	0.11	0.00
3000	0.10	0.09	0.11	0.12	0.13	0.06	0.13	0.03	0.02	0.06	0.12	0.02
3250	0.11	0.10	0.12	0.15	0.16	0.06	0.15	0.04	0.02	0.06	0.13	0.02
3500	0.12	0.11	0.12	0.16	0.17	0.09	0.15	0.04	0.03	0.07	0.15	0.04
3750	0.14	0.13	0.14	0.19	0.20	0.09	0.15	0.05	0.03	0.08	0.16	0.07
4000	0.15	0.14	0.14	0.21	0.22	0.09	0.19	0.05	0.04	0.08	0.17	0.09
4250	0.17	0.15	0.14	0.24	0.28	0.13	0.19	0.06	0.04	0.09	0.19	0.11
4500	0.19	0.17	0.15	0.26	0.32	0.14	0.22	0.07	0.04	0.09	0.20	0.12
4750	0.20	0.18	0.16	0.29	0.37	0.17	0.25	0.07	0.05	0.10	0.21	0.16
5000	0.22	0.20	0.16	0.34	0.43	0.20	0.29	0.08	0.06	0.10	0.23	0.18
5250	0.24	0.22	0.16	0.37	0.47	0.22	0.32	0.08	0.06	0.11	0.24	0.19
5500	0.25	0.23	0.18	0.44	0.54	0.25	0.34	0.09	0.07	0.12	0.25	0.22
5750	0.27	0.25	0.19	0.49	0.59	0.31	0.45	0.10	0.07	0.12	0.27	0.25
6000	0.29	0.27	0.20	0.54	0.64	0.33	0.52	0.10	0.08	0.13	0.28	0.27

### POWER EXHAUST FAN PERFORMANCE

Return Air System Static Pressure	Air Volume Exhausted
in. w.g.	cfm
0	3175
0.05	2955
0.10	2685
0.15	2410
0.20	2165
0.25	1920
0.30	1420
0.35	1200

### MINIMUM AIR VOLUME REQUIRED FOR USE WITH OPTIONAL ELECTRIC HEAT

Electric Heat kW	Minimum cfm
7.5	1750
15	2250
22.5	2250
30	2750
45	2750
60	3500

## Cooling Start-Up

**IMPORTANT**-The crankcase heater must be energized for 24 hours before attempting to start compressor. Set thermostat so there is no demand to prevent compressors from cycling. Apply power to unit.

### A-Start-Up

- 1- Initiate full load cooling operation using the following mobile service app menu path:  
RTU MENU > SERVICE > COMPONENT TEST > COOLING > COOLING STAGE
- 2- Refer to Cooling Operation section for cooling start-up.
- 3- Units have two refrigerant circuits. See figure 22.
- 4- Each refrigerant circuit is charged with R410A refrigerant. See unit rating plate for correct amount of charge.
- 5- Refer to Refrigerant Check and Charge section for proper method to check refrigerant charge.

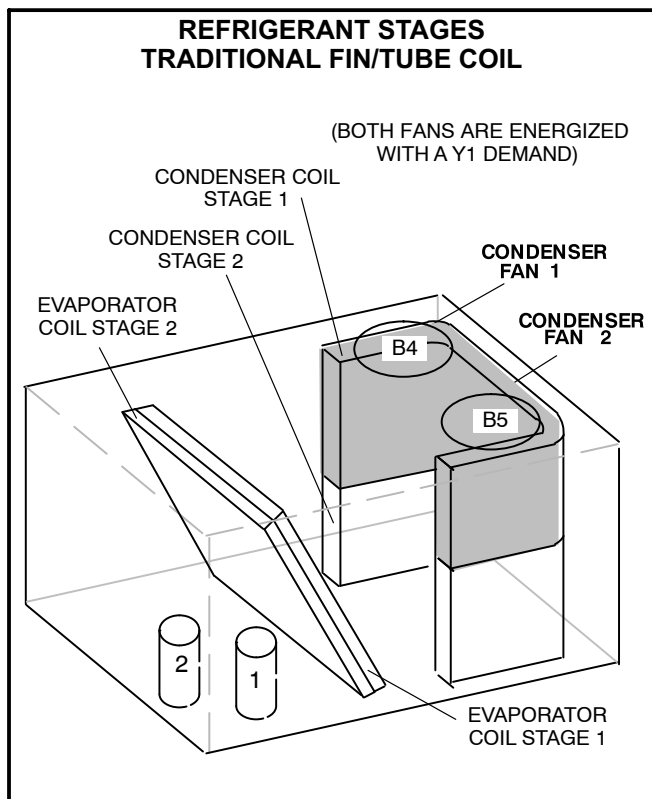

**FIGURE 22**

### B-R410A Refrigerant

Units charged with R410A refrigerant operate at much higher pressures than R22. The expansion valve and liquid line drier provided with the unit are approved for use with R410A. Do not replace them with components designed for use with R22.

R410A refrigerant is stored in a pink cylinder.

Manifold gauge sets used with systems charged with R410A refrigerant must be capable of handling the higher system operating pressures. The gauges should be rated for use with pressures of 0-800 on the high side and a low side of 30" vacuum to 250 psi with dampened speed to 500 psi. Gauge hoses must be rated for use at up to 800 psi of pressure with a 4000 psi burst rating.

## **▲ IMPORTANT**

**Mineral oils are not compatible with R410A. If oil must be added, it must be a polyol ester oil.**

### C-Compressor Controls

See unit wiring diagram to determine which controls are used on each unit.

- 1- High Pressure Switch (S4, S7)  
The compressor circuit is protected by a high pressure switch which opens at 640 psig + 10 psig (4413 kPa + 70 kPa) and automatically resets at 475 psig + 20 psig (3275kPa + 138 kPa).
- 2- Low Pressure Switch (S87, S88)  
The compressor circuit is protected by a loss of charge switch. Switch opens at 40 psig + 5 psig (276 + 34 kPa) and automatically resets at 90 psig + 5 psig (621 kPa + 34 kPa).
- 3- Crankcase Heater (HR1, HR2)  
Compressors have belly band compressor oil heaters which must be on 24 hours before running compressors. Energize by setting thermostat so that there is no cooling demand, to prevent compressor from cycling, and apply power to unit..
- 4- Diagnostic Sensors (RT46-RT49)  
Four thermistors are located on specific points in the refrigeration circuit. The thermistors provide constant temperature feedback to the Unit Controller to protect the compressor. Thermistors take the place of the freezestat and low ambient pressure switch.

## D-Refrigerant Charge and Check

**WARNING-Do not exceed nameplate charge under any condition.**

This unit is factory charged and should require no further adjustment. If the system requires additional refrigerant, reclaim the charge, evacuate the system, and add required nameplate charge.

**NOTE** - System charging is not recommended below 60°F (15°C). In temperatures below 60°F (15°C) , the charge **must** be weighed into the system.

If weighing facilities are not available, or to check the charge, use the following procedure:

**IMPORTANT - Charge unit in standard cooling mode at full load..**

- 1- Make sure outdoor coil is clean. Attach gauge manifolds and operate unit at full CFM in cooling mode with economizer disabled until system stabilizes (approximately five minutes). Make sure all outdoor air dampers are closed.

Mobile service app: RTU Menu>Component Test>Cooling>Cooling Stage 3.

- 2- Check each system separately with all stages operating. Compare the normal operating pressures to the pressures obtained from the gauges. Check unit components if there are significant differences.
- 3- Measure the outdoor ambient temperature and the suction pressure. Refer to the charging curve to determine a target liquid temperature.

**NOTE** - Pressures are listed for sea level applications.

- 4- Use the same thermometer to accurately measure the liquid temperature (in the outdoor section).
  - If measured liquid temperature is higher than the target liquid temperature, add refrigerant to the system..
  - If measured liquid temperature is lower than the target liquid temperature, recover some refrigerant from the system.
- 5- Add or remove charge in increments. Allow the system to stabilize each time refrigerant is added or removed.
- 6- Continue the process until measured liquid temperature agrees with the target liquid temperature. Do not go below the target liquid temperature when adjusting charge. .Note that suction pressure can change as charge is adjusted.
- 7- Example: At 95°F outdoor ambient and a measured suction pressure of 130psig, the target liquid temperature is 96°F. For a measured liquid temperature of 106°F, add charge in increments until measured liquid temperature agrees with the target liquid temperature.

**TABLE 4 581114-01  
LGT/LCT092**

Normal Operating Pressures												
	Outdoor Coil Entering Air Temperature											
	65 °F		75 °F		85 °F		95 °F		105 °F		115 °F	
	Suct (psig)	Disc (psig)	Suct (psig)	Disc (psig)	Suct (psig)	Disc (psig)	Suct (psig)	Disc (psig)	Suct (psig)	Disc (psig)	Suct (psig)	Disc (psig)
Circuit 1	101	230	103	266	106	312	108	361	111	436	114	514
	108	233	111	268	113	313	116	366	119	435	122	512
	126	238	128	271	131	315	133	371	136	433	139	508
	147	244	149	275	152	317	154	376	157	431	159	505
Circuit 2	120	236	122	273	124	315	126	364	128	418	129	478
	129	239	131	275	133	318	135	366	137	420	139	480
	147	245	150	281	153	323	155	370	157	424	160	484
	168	252	171	287	174	328	177	376	179	429	182	488

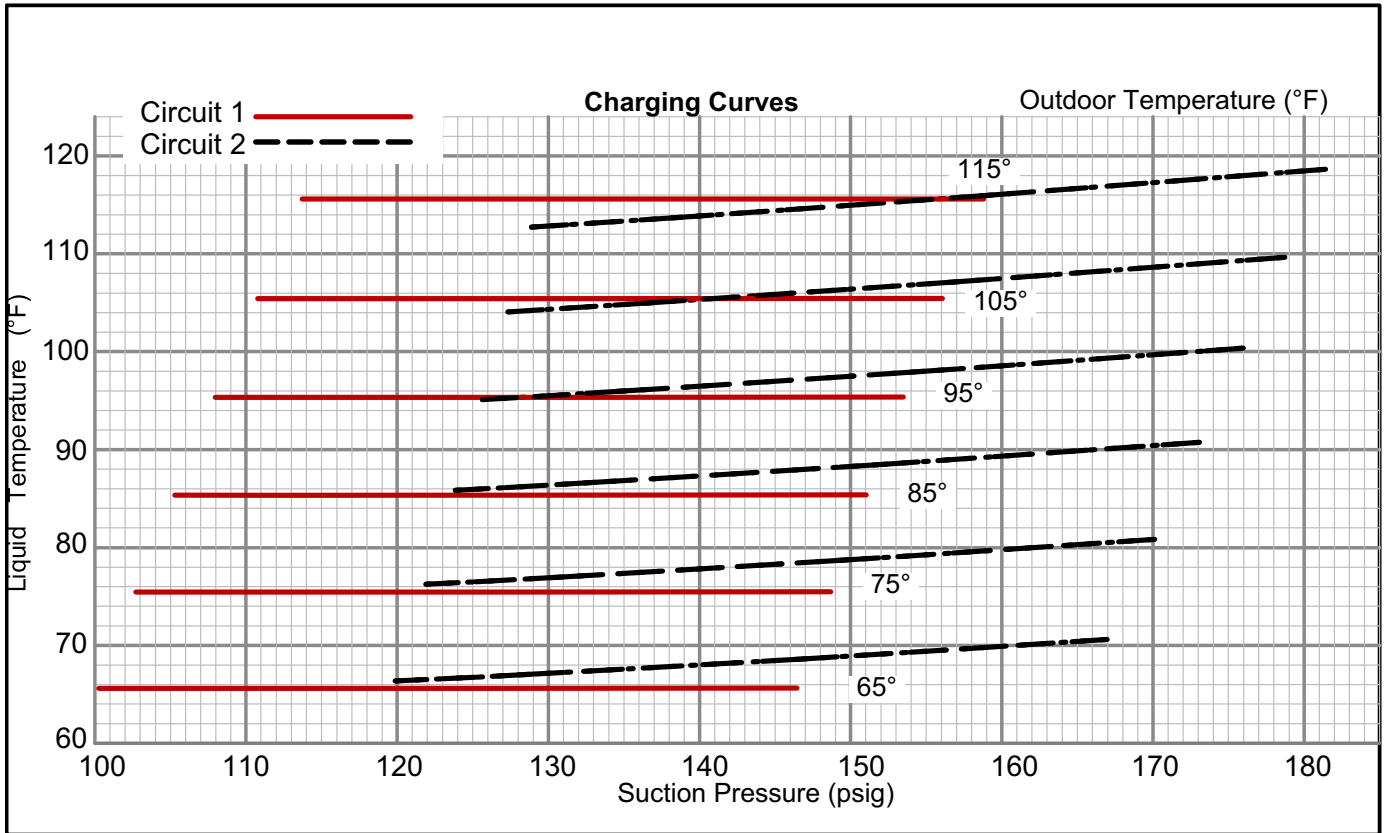

**TABLE 5 581115-01  
LGT/LCT102**

Normal Operating Pressures												
	Outdoor Coil Entering Air Temperature											
	65 °F		75 °F		85 °F		95 °F		105 °F		115 °F	
	Suct (psig)	Disc (psig)	Suct (psig)	Disc (psig)	Suct (psig)	Disc (psig)	Suct (psig)	Disc (psig)	Suct (psig)	Disc (psig)	Suct (psig)	Disc (psig)
Circuit 1	109	228	111	266	114	312	116	362	118	430	119	502
	117	231	119	267	122	312	125	363	127	427	129	497
	133	239	137	272	140	314	143	366	146	423	148	490
	151	250	155	280	159	319	163	373	166	423	169	487
Circuit 2	124	243	126	280	128	327	130	383	132	448	135	523
	132	249	134	285	136	331	139	385	142	449	144	522
	150	261	153	294	155	337	158	388	161	449	164	520
	170	271	173	301	176	341	179	390	183	448	186	515

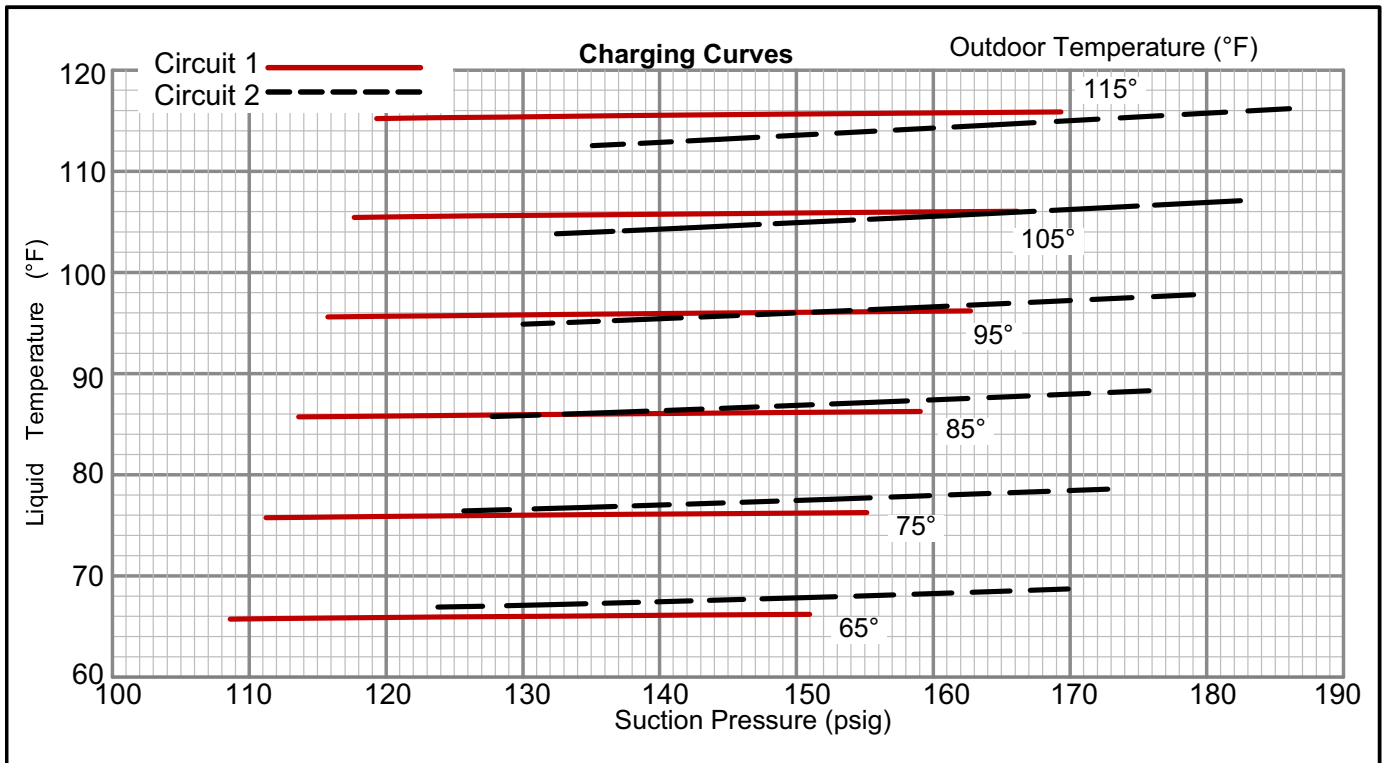

**TABLE 6 581116-01  
LGT/LCT120**

Normal Operating Pressures													
Outdoor Coil Entering Air Temperature													
65 °F		75 °F		85 °F		95 °F		105 °F		115 °F			
Suct (psig)	Disc (psig)	Suct (psig)	Disc (psig)	Suct (psig)	Disc (psig)	Suct (psig)	Disc (psig)	Suct (psig)	Disc (psig)	Suct (psig)	Disc (psig)		
Circuit 1		98	234	100	274	103	320	106	369	109	431	113	496
		105	236	107	275	110	320	113	372	116	430	120	494
		122	242	124	279	127	323	130	374	133	429	137	491
		140	249	143	285	145	327	149	378	152	430	157	491
Circuit 2		118	249	120	286	122	330	124	381	126	440	128	505
		127	252	129	288	131	331	133	382	135	439	138	504
		145	261	147	295	150	336	153	385	155	441	158	504
		164	274	167	307	170	346	173	393	176	447	179	508

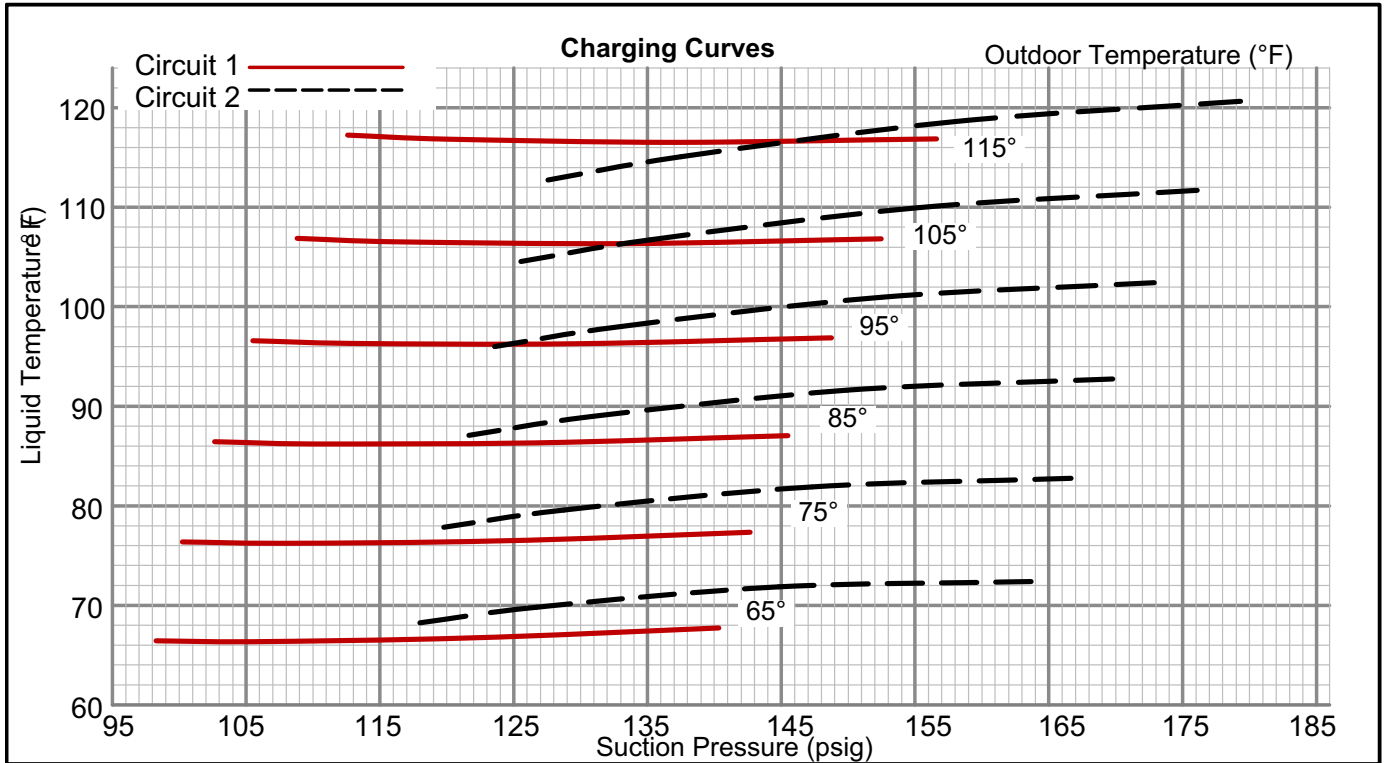

**TABLE 7 581117-01  
LGT/LCT150**

Normal Operating Pressures												
	Outdoor Coil Entering Air Temperature											
	65 °F		75 °F		85 °F		95 °F		105 °F		115 °F	
	Suct (psig)	Disc (psig)	Suct (psig)	Disc (psig)	Suct (psig)	Disc (psig)	Suct (psig)	Disc (psig)	Suct (psig)	Disc (psig)	Suct (psig)	Disc (psig)
Circuit 1	100	238	103	274	106	317	108	365	111	420	113	481
	107	240	111	276	114	318	117	366	120	421	122	482
	123	249	127	284	131	325	135	373	138	427	142	487
	137	263	143	298	148	338	152	385	157	439	161	498
Circuit 2	112	264	115	302	118	345	120	393	123	446	125	503
	119	268	122	307	126	350	129	398	132	451	134	508
	132	280	136	319	141	363	145	411	149	464	153	522
	144	297	150	337	155	381	161	429	166	483	171	542

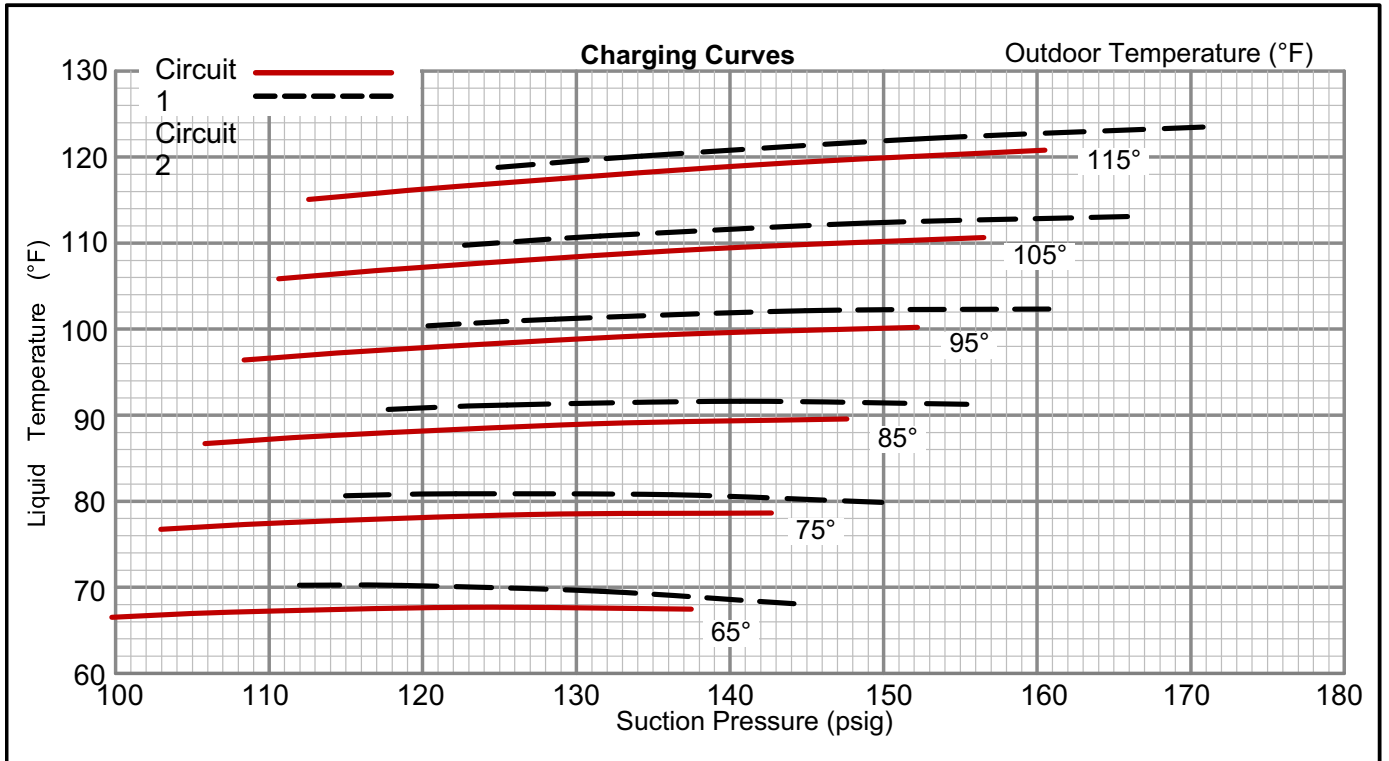

## Diagnostic Sensors

Units are equipped with four factory-installed thermistors (RT46 - RT49) located on different points on the refrigerant circuit.

The thermistors provide the Unit Controller with constant temperature readings of four specific locations on the

refrigeration circuit. These temperatures are used as feedback in certain modes of unit operation. In addition, the Unit Controller uses these temperatures to initiate alarms such as loss of condenser or evaporator airflow and loss of charge.

Each thermistor must be specifically placed for proper unit operation and to initiate valid alarms. See figure 23 and figure 24 proper locations.

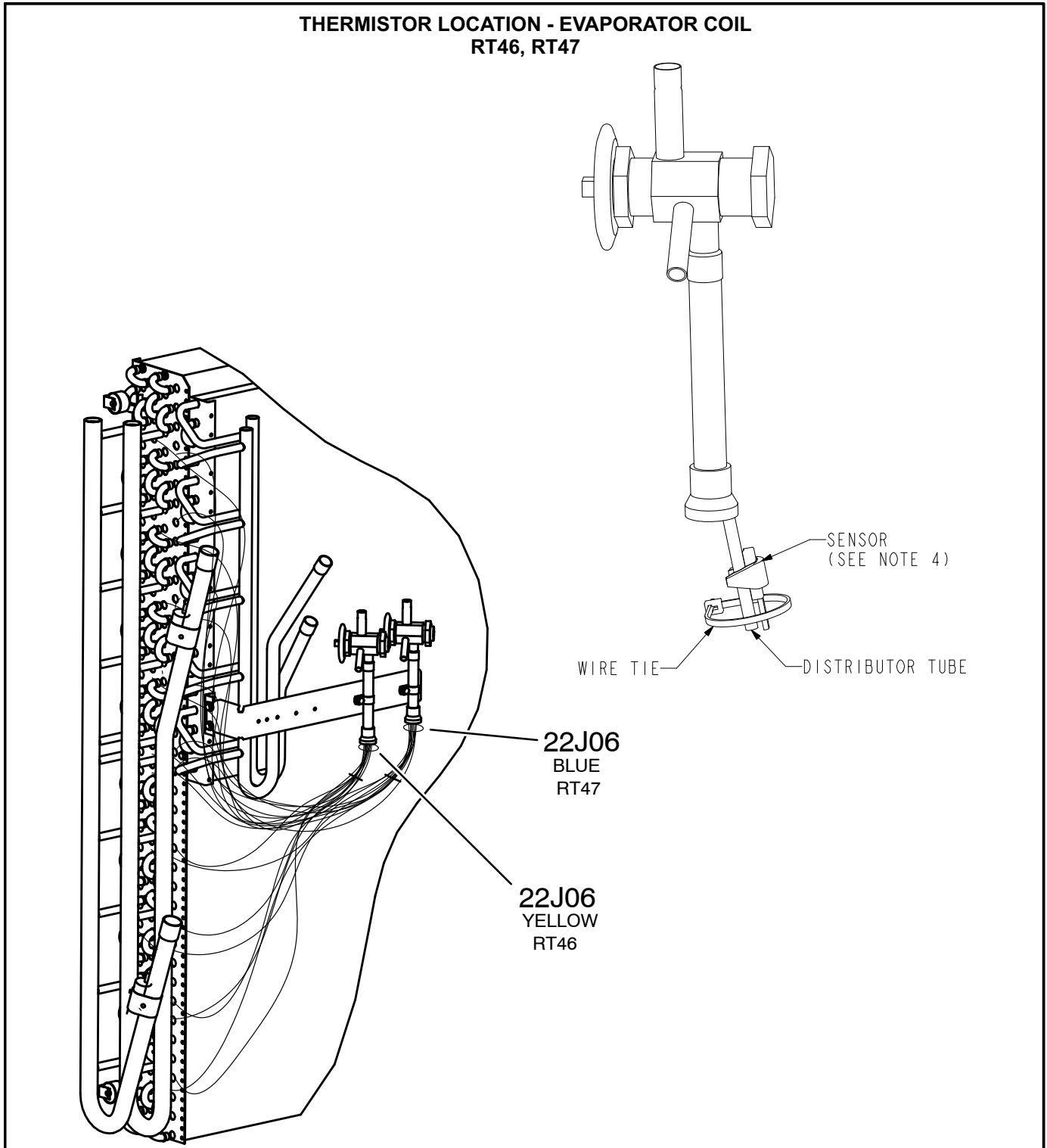

**FIGURE 23**



**THERMISTOR LOCATION - CONDENSER COIL  
RT48, RT49**

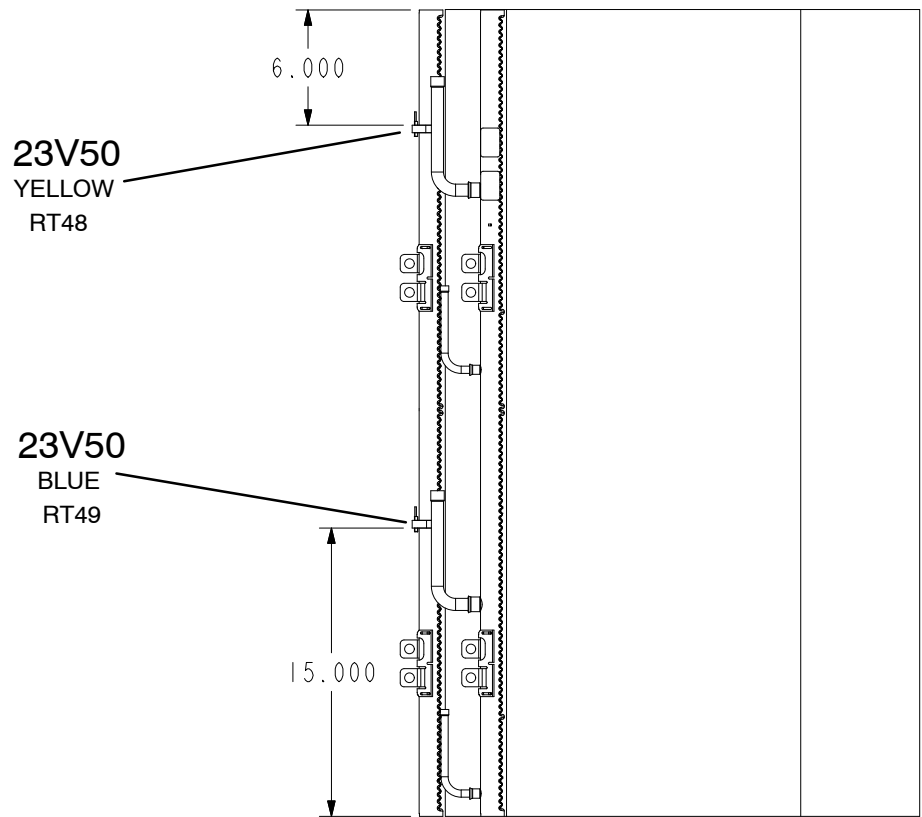
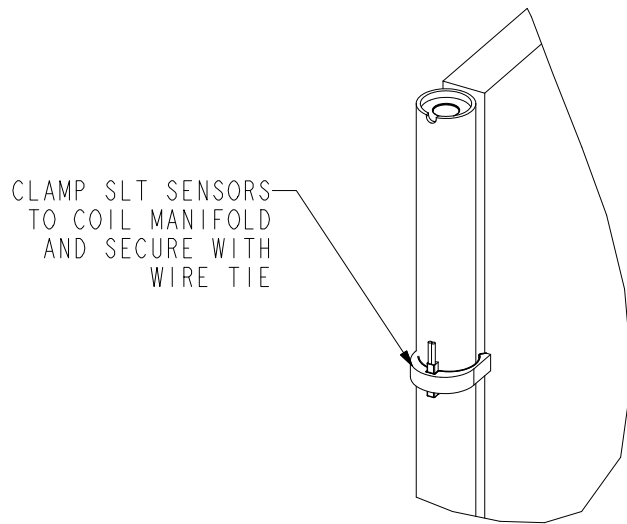

DETAILS NOT TO SCALE

**FIGURE 24**

## Gas Heat Start-Up (Gas Units)

FOR YOUR SAFETY READ BEFORE LIGHTING

### ⚠️ WARNING



Electric shock hazard. Can cause injury or death. Do not use this unit if any part has been under water. Immediately call a qualified service technician to inspect the unit and to replace any part of the control system and any gas control which has been under water.

### ⚠️ WARNING



Danger of explosion. Can cause injury or product or property damage. If overheating occurs or if gas supply fails to shut off, shut off the manual gas valve to the appliance before shutting off electrical supply.

### ⚠️ WARNING



Electric shock hazard. Can cause injury or death. Before attempting to perform any service or maintenance, turn the electrical power to unit OFF at disconnect switch(es). Unit may have multiple power supplies.

### ⚠️ WARNING

#### SMOKE POTENTIAL

The heat exchanger in this unit could be a source of smoke on initial firing. Take precautions with respect to building occupants and property. Vent initial supply air outside when possible.

BEFORE LIGHTING smell all around the appliance area for gas. Be sure to smell next to the floor because some gas is heavier than air and will settle on the floor.

Use only your hand to push in or turn the gas control knob. Never use tools. If the knob will not push in or turn by hand, do not try to repair it, call a qualified service technician. Force or attempted repair may result in a fire or explosion.

### ⚠️ WARNING



Danger of explosion. Can cause injury or death. Do not attempt to light manually. Unit has a direct spark ignition system.

This unit is equipped with an automatic spark ignition system. There is no pilot. In case of a safety shutdown, move thermostat switch to **OFF** and return the thermostat switch to **HEAT** to reset ignition control.

#### A-Placing Unit In Operation

### ⚠️ WARNING



Danger of explosion and fire. Can cause injury or product or property damage. You must follow these instructions exactly.

Gas Valve Operation for Honeywell VR8205Q/VR8305Q and White Rodgers 36H54 (figure 25 and 26).

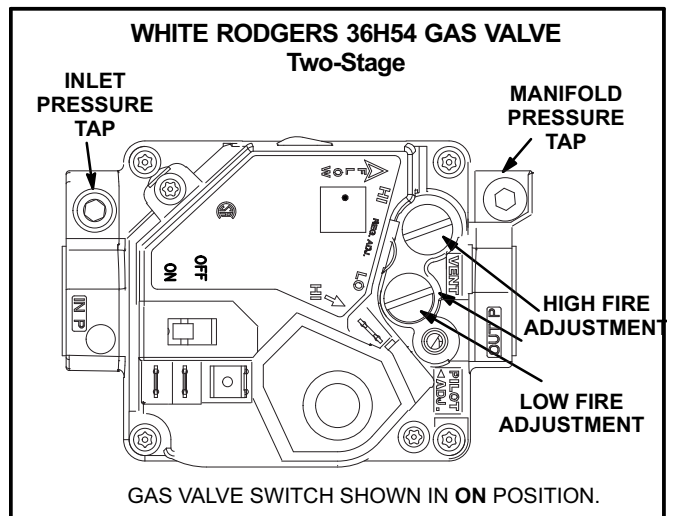

FIGURE 25

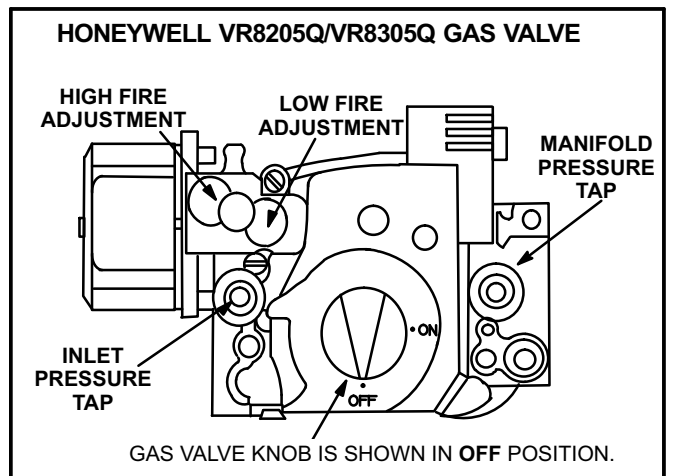





FIGURE 26

- 1- Set thermostat to lowest setting.
- 2- Turn off all electrical power to appliance.
- 3- This appliance is equipped with an ignition device which automatically lights the burner. Do **not** try to light the burner by hand.
- 4- Open or remove the heat section access panel.

- 5- Turn gas valve switch to **OFF**. See figure 25. On Honeywell VR8305Q gas valves, turn the knob on the gas valve clockwise  to “**OFF**”. Do not force. See figure 26.
- 6- Wait five (5) minutes to clear out any gas. If you then smell gas, **STOP!** Immediately call your gas supplier from a neighbor's phone. Follow the gas supplier's instructions. If you do not smell gas, go to the next step.
- 7- Turn gas valve switch to **ON**. See figure 25. On Honeywell VR8305Q gas valves, turn the knob on the gas valve counterclockwise  to “**ON**”. Do not force. See figure 26.
- 8- Close or replace the heat section access panel.
- 9- Turn on all electrical power to appliance.
- 10- Set thermostat to desired setting.
- 11- The ignition sequence will start.
- 12- If the appliance does not light the first time (gas line not fully purged), it will attempt up to two more ignitions before locking out.
- 13- If lockout occurs, repeat steps 1 through 10.
- 14- If the appliance will not operate, follow the instructions “Turning Off Gas to Appliance” and call your service technician or gas supplier.

#### Turning Off Gas to Unit

- 1- If using an electromechanical thermostat, set to the lowest setting.
- 2- Before performing any service, turn off all electrical power to the appliance.
- 3- Open or remove the heat section access panel.
- 4- Turn gas valve switch to **OFF**. On Honeywell VR8305Q gas valves, turn the knob on the gas valve clockwise  to “**OFF**”. Do not force.
- 5- Close or replace the heat section access panel.

## **WARNING**



**Danger of explosion. Can cause injury or death. Do not attempt to light manually. Unit has a direct spark ignition system.**

### Heating Operation and Adjustments

#### (Gas Units)

##### A-Heating Sequence of Operation

- 1- On a heating demand the combustion air inducer starts immediately.
- 2- Combustion air pressure switch proves inducer operation. After a 30-second pre-purge, power is allowed to ignition control. Switch is factory set and requires no adjustment.

- 3- Spark ignitor energizes and gas valve solenoid opens.
- 4- Spark ignites gas, ignition sensor proves the flame and combustion continues.
- 5- If flame is not detected after first ignition trial, ignition control will repeat steps 3 and 4 two more times before locking out the gas valve.
- 6- For troubleshooting purposes, an ignition attempt after lock out may be re-established manually. Move thermostat to “OFF” and return thermostat switch to “HEAT” position.

##### B-Limit Controls

Limit controls are factory-set and are not adjustable. The primary limit is located on the blower deck to the right of the blower housing.

##### C-Heating Adjustment

Main burners are factory-set and do not require adjustment.

The following manifold pressures are listed on the gas valve.

- Natural Gas Units - Low Fire - 1.6” w.c. (not adjustable)
- Natural Gas Units - High Fire - 3.7” w.c.
- LP Gas Units - Low Fire - 5.5” w.c. (not adjustable)
- LP Gas Units - High Fire - 10.5” w.c.

### Electric Heat Start-Up (Cooling Units)

#### Factory- or Field-Installed Option

Electric heat will stage on and cycle with thermostat demand. Number of stages of electric heat will vary depending on electric heat assembly. See electric heat wiring diagram on unit for sequence of operation.

### SCR Electric Heat Controller (LCT Units)

Optional factory-installed SCR (A38) will provide small amounts of power to the electric heat elements to efficiently maintain warm duct air temperatures when there is no heating demand. The SCR maintains duct air temperature based on input from a field-provided and installed thermostat (A104) and duct sensor (RT20). SCR is located in the electric heat compartment in front of the elements. Use only with a thermostat.

Use the instructions provided with the thermostat to set DIP switches as follows: S1 On, S2 Off, S3 Off. Use the instructions provided with the duct sensor to install sensor away from electric element radiant heat and in a location where discharge air is a mixed average temperature.

Once power is supplied to unit, zero SCR as follows:

- 1- Adjust thermostat (A104) to minimum position.
- 2- Use a small screwdriver to slowly turn the ZERO potentiometer on the SCR until the LED turns solid red.
- 3- Very slowly adjust the potentiometer the opposite direction until the LED turns off.

## Cooling Operation

This is a summary of cooling operation. Refer to the sequence of operation provided in the Engineering Handbook or Service Manual for more detail.

*Note - Free cooling is locked-out during reheat operation. Refer to hot gas reheat start-up and operation section for details.*

### A-Two-Stage Thermostat

#### 1-Economizer With Outdoor Air Suitable

##### Y1 Demand -

- Compressors Off
- Blower Cooling Low
- Dampers modulate

##### Y2 Demand -

- Compressors Off
- Blower Cooling High
- Dampers Modulate

*Note - If dampers are at maximum open for three minutes, compressor 1 is energized and runs at full load, blower stays on cooling high.*

#### 2-No Economizer or Outdoor Air Not Suitable

##### Y1 Demand -

- Compressor 1 on Full Load
- Blower Cooling Low
- Dampers Minimum Position

##### Y2 Demand -

- Compressors On
- Blower Cooling High
- Dampers Minimum Position

### B-Room Sensor

#### 1-Economizer With Outdoor Air Suitable

- Compressors Off
- Blower Modulates
- Dampers modulate

*Note - If dampers are at maximum open for five minutes, compressors are energized and the blower modulates.*

#### 2-No Economizer or Outdoor Air Not Suitable

- Compressors Modulate
- Blower Modulates
- Dampers Minimum Position

### C-Three-Stage Thermostat

#### 1-Economizer With Outdoor Air Suitable

##### Y1 Demand -

- Compressors Off
- Blower Cooling Low\*
- Dampers Modulate

##### Y2 Demand -

- Compressors Off
- Blower Cooling High\*
- Dampers Modulate

*Note - If dampers are at maximum open for three minutes, compressor 1 is energized and runs at full load, blower stays on cooling high.*

##### Y3 Demand -

- Compressors On
- Blower Cooling High\*
- Dampers Maximum Open
- Compressors On

\*In discharge air control (DAC) mode, blower operates to maintain duct static pressure.

#### 2-Economizer With Outdoor Air Not Suitable

##### Y1 Demand -

- Compressor 1 On Part Load, Compressor 2 On (in DAC mode, Compressor 2 Off)
- Blower Cooling Low\*

##### Y2 Demand -

- Compressor 1 On Part Load, Compressor 2 On
- Blower Cooling Medium\*
- Dampers Minimum Position

##### Y3 Demand -

- Compressors On (in DAC mode, Compressor 1 on Full Load, Compressor 2 On)
- Blower Cooling High\*
- Dampers Minimum Position
- Compressors On

\*In discharge air control (DAC) mode, blower operates to maintain duct static pressure.

## Modulating Hot Gas Reheat Start-Up And Operation

### General

Hot gas reheat units provide a dehumidifying mode of operation. These units contain a reheat coil adjacent to and downstream of the evaporator coil. Reheat coil solenoid valve, L14, routes hot discharge gas from the compressor to the reheat coil. Return air pulled across the evaporator coil is cooled and dehumidified; the reheat coil adds heat to supply air. See figure 27 for reheat refrigerant routing and figure 28 for standard refrigerant routing.

### L14 Reheat Coil Solenoid Valve

When Unit Controller input (Unit Controller J298-5 or J299-8) indicates room conditions require dehumidification, L14 reheat valve is energized (Unit Controller J394-1) and refrigerant is routed to the reheat coil.

### Reheat Setpoint

Reheat is factory-set to energize when indoor relative humidity rises above 60% (default).

The reheat setpoint can be adjusted by changing mobile service app Settings - Control menu. A setting of 100% will operate reheat from an energy management system digital output.

The reheat setpoint can also be adjusted using an optional Network Control Panel (NCP). Reheat will terminate when the indoor relative humidity falls 3% (57% default) or the digital output de-energizes. The reheat deadband can be adjusted at Settings - Control menu.

### Check-Out

Test hot gas reheat operation using the following procedure.

- 1- Make sure reheat is wired as shown in wiring section.
- 2- Make sure unit is in local thermostat mode.
- 3- Select:

RTU MENU > SERVICE > COMPONENT TEST >  
DEHUMIDIFICATION

*The blower and compressor 1 (reheat) should be operating. DEHUMIDIFIER 1 ON will appear.*

- 4- Press STOP to discontinue the testing mode.

*Compressor 1 (reheat) and blower should de-energize.*

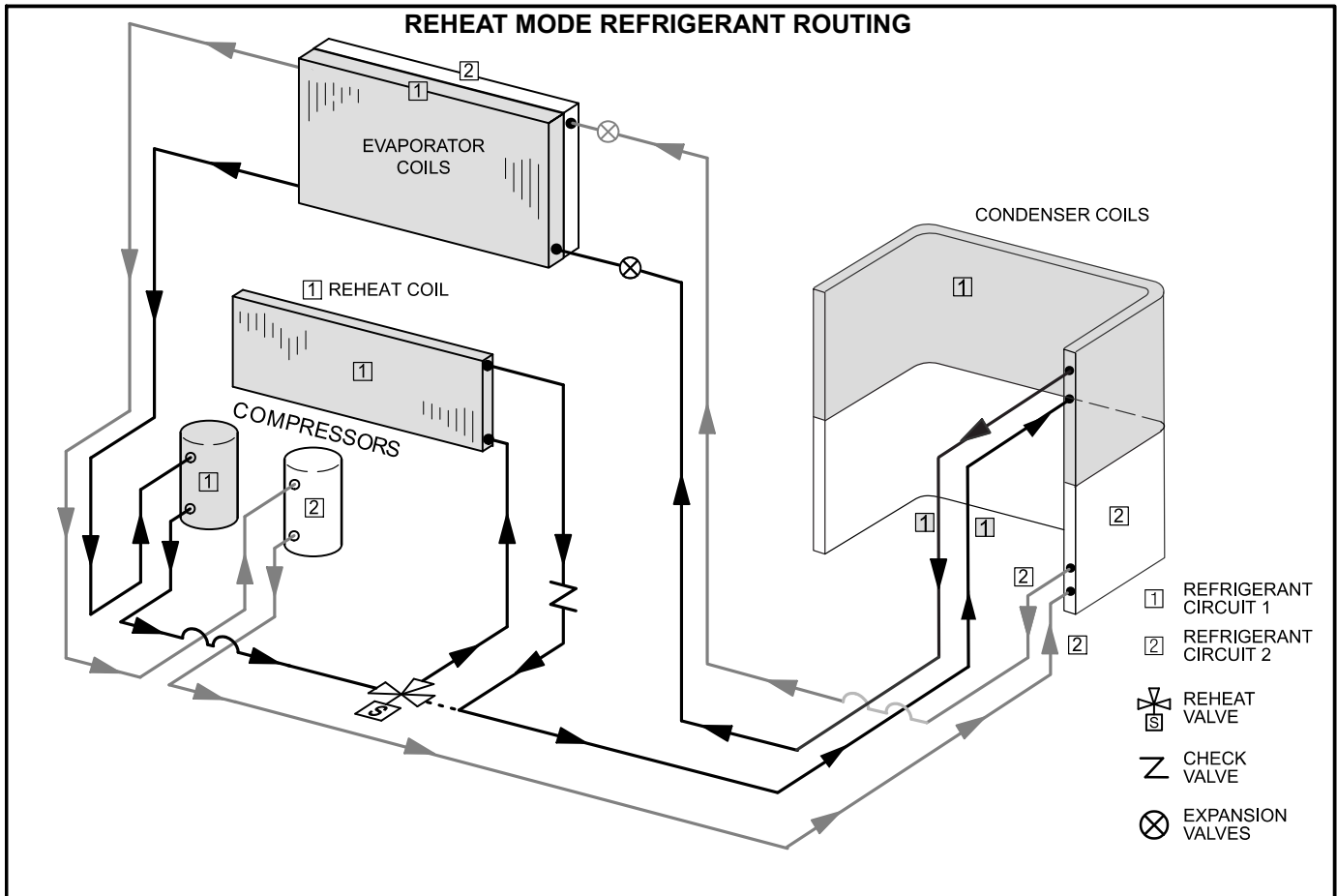

**FIGURE 27**

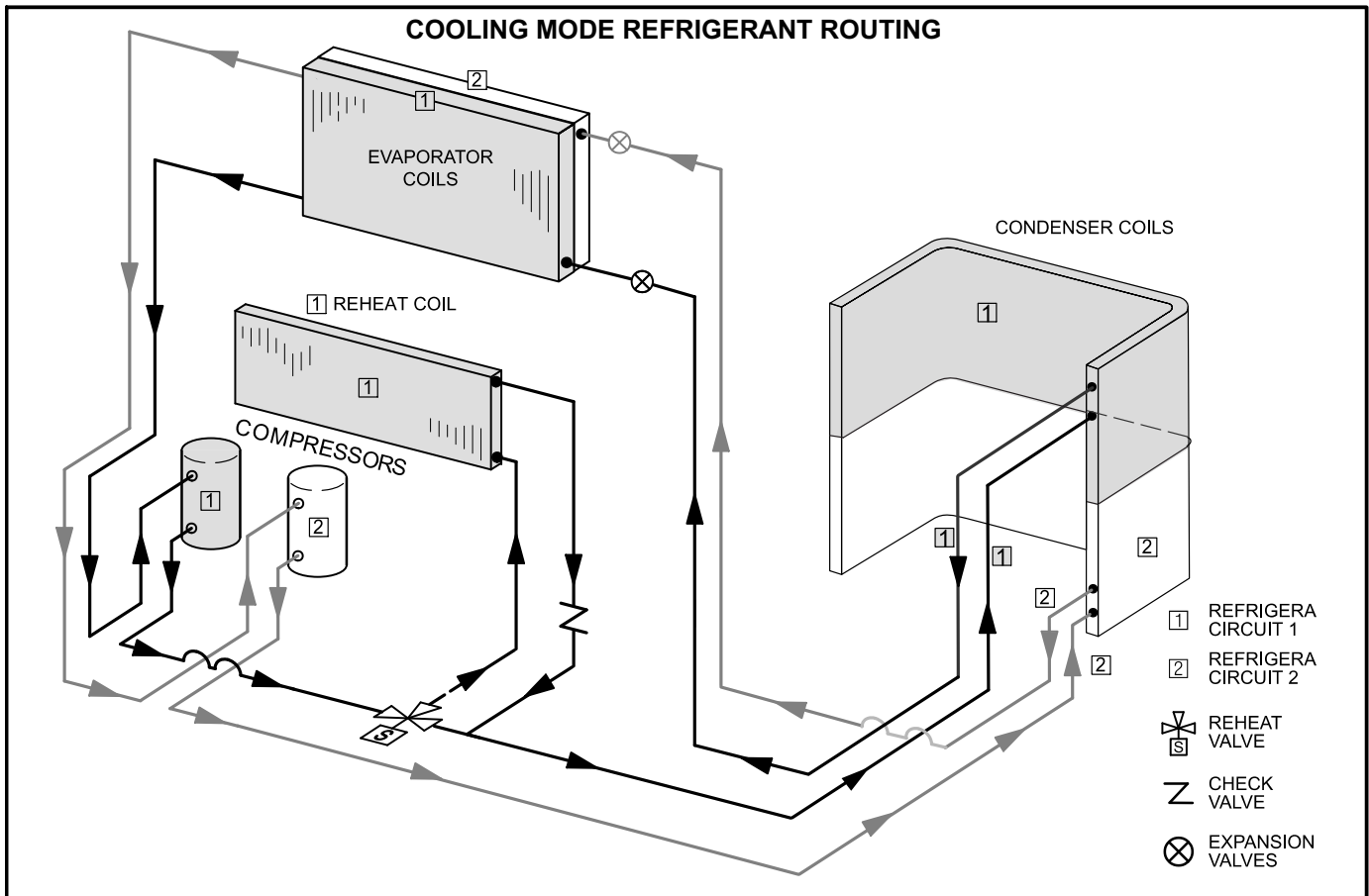

**FIGURE 28**

**Default Reheat Operation**

**TABLE 8**

**Reheat Operation - Two Cooling Stages - Default**

T'stat & Humidity Demands	Operation
Reheat Only	Compressor 1 Full Load, Reheat ON, Blower Low
Reheat & Y1	Compressor 1 & 2 Full Load, Reheat ON, Blower High
Reheat & Y1 & Y2	Compressor 1 & 2 Full Load, Reheat OFF, Blower High

\*If there is no reheat demand and outdoor air is suitable, free cooling will operate.

\*\*If there is no reheat demand and outdoor air is suitable, free cooling and compressor 1 will operate.

**TABLE 9**

**Reheat Operation - Three Cooling Stages - Default**

T'stat & Humidity Demands	Operation
Reheat Only	Compressor 1 Full Load, Reheat ON, Blower Low
Reheat & Y1	Compressor 1 & 2 Full Load, Reheat ON, Blower Medium
Reheat & Y1, Y2	Compressor 1 & 2 Full Load, Reheat ON, Blower High
Reheat & Y1, Y2, Y3	Compressor 1 & 2 Full Load, No Reheat OFF, Blower High

\*If there is no reheat demand and outdoor air is suitable, free cooling will operate.

\*\*If there is no reheat demand and outdoor air is suitable, free cooling and compressor 1 will operate.

## Service

The unit should be inspected once a year by a qualified service technician.

## ⚠ CAUTION

Label all wires prior to disconnection when servicing controls. Wiring errors can cause improper and dangerous operation. Verify proper operation after servicing.

### A-Filters

Units are equipped with four 20 X 25 X 2" filters. Filters should be checked monthly and replaced when necessary with filters of like kind and size. Take note of air flow direction marking on filter frame when reinstalling filters. See figure 29.

*NOTE-Filters must be U.L.C. certified or equivalent for use in Canada.*

### B-Lubrication

All motors are lubricated at the factory. No further lubrication is required.

### C-Burners (Gas Units)

Periodically examine burner flames for proper appearance during the heating season. Before each heating season examine the burners for any deposits or blockage which may have occurred.

Clean burners as follows:

- 1- Turn off both electrical power and gas supply to unit.
- 2- Remove burner compartment access panel.
- 3- Remove screws securing burner assembly to burner support and remove assembly. See figure 30. Clean as necessary.
- 4- Locate the ignitor under the left burners. Check ignitor spark gap with appropriately sized twist drills or feeler gauges. See figure 31.
- 5- Check the alignment of the ignitor and the sensor as shown in figure 32 and table 10.

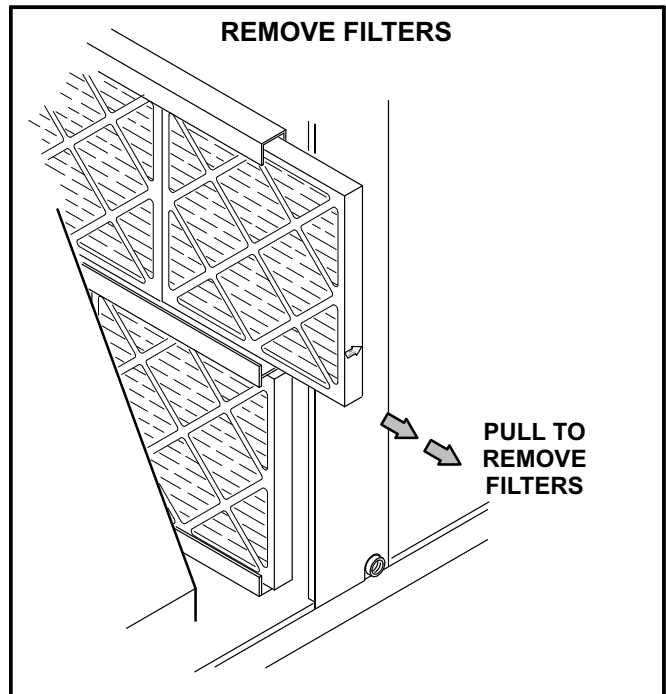

FIGURE 29

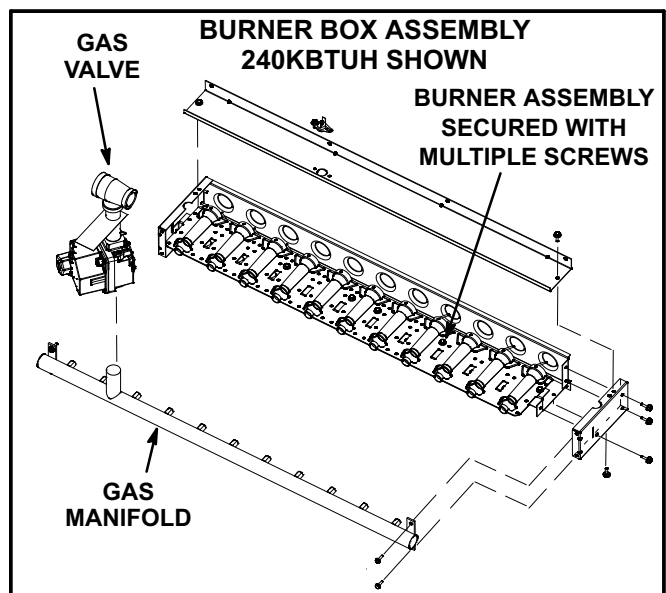

FIGURE 30

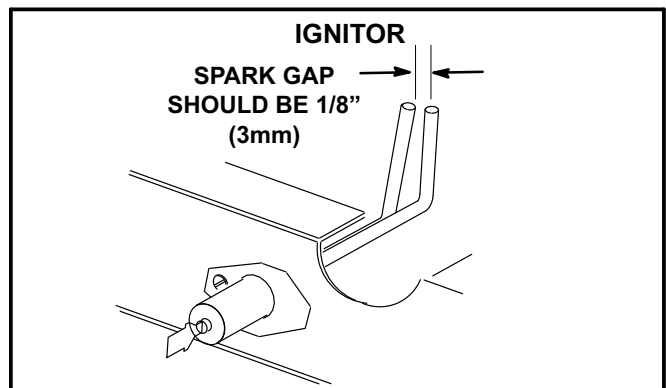

FIGURE 31

- 6- Replace burners and screws securing burner.
- 7- Replace access panel.
- 8- Restore electrical power and gas supply. Follow lighting instructions attached to unit and use inspection port in access panel to check flame.

**TABLE 10**

Dimension	Unit Btuh Input	Length - in. (mm)	
		Ignitor	Sensor
A	130K	7-3/4 (197)	11 (279)
B	180K	5 (127)	5-1/2 (140)
C	240K	2-1/4 (57)	2-3/4 (70)

**⚠ WARNING**

**Danger of explosion. Can cause injury or death. Do not overtighten main burner mounting screws. Snug tighten only.**

**D-Combustion Air Inducer (Gas Units)**

A combustion air proving switch checks combustion air inducer operation before allowing power to the gas controller. Gas controller will not operate if inducer is obstructed.

Under normal operating conditions, the combustion air inducer wheel should be checked and cleaned prior to the heating season. However, it should be examined periodically during the heating season to establish an ideal cleaning schedule. With power supply disconnected, the condition of the inducer wheel can be determined by looking through the vent opening.

Clean combustion air inducer as follows:

- 1- Shut off power supply and gas to unit.
- 2- Disconnect pressure switch air tubing from combustion air inducer port.
- 3- Remove and retain screws securing combustion air inducer to flue box. Remove vent connector. See figure 33.
- 4- Clean inducer wheel blades with a small brush and wipe off any dust from housing. Clean accumulated dust from front of flue box cover.
- 5- Return combustion air inducer motor and vent connector to original location and secure with retained screws. It is recommended that the combustion air inducer gasket be replaced during reassembly.
- 6- Clean combustion air inlet louvers on heat access panel using a small brush.

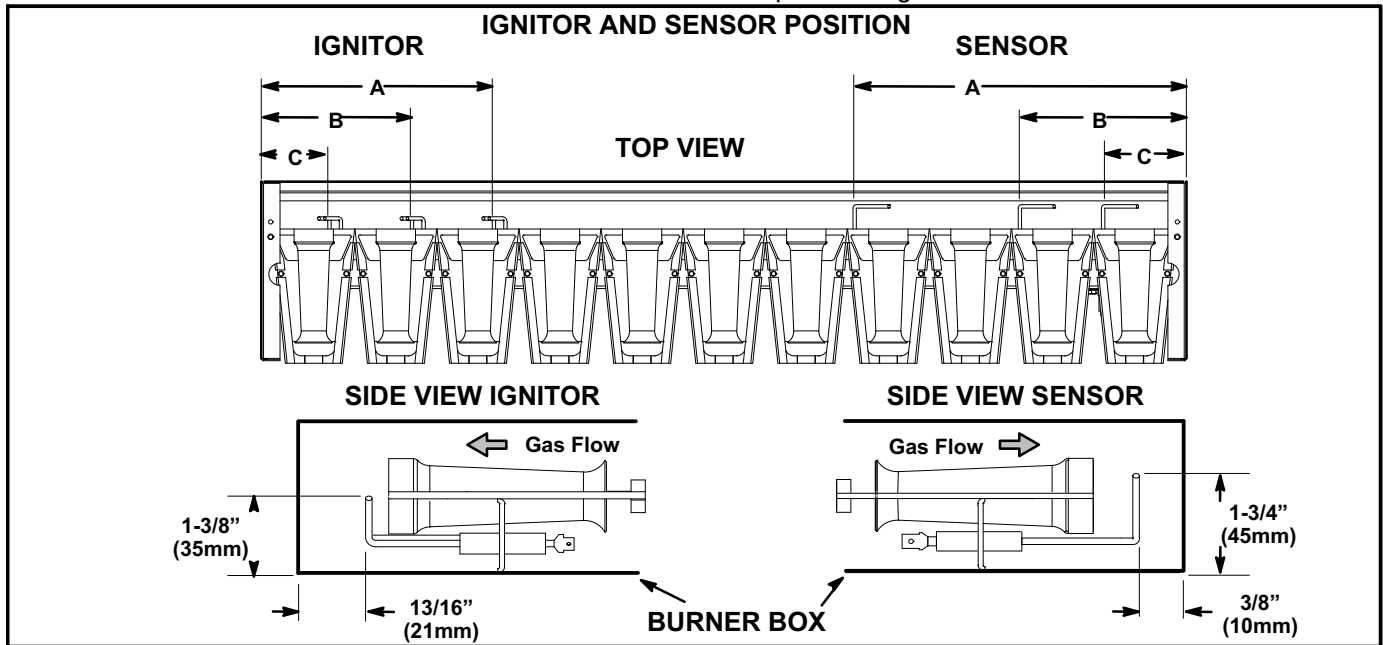

**FIGURE 32**



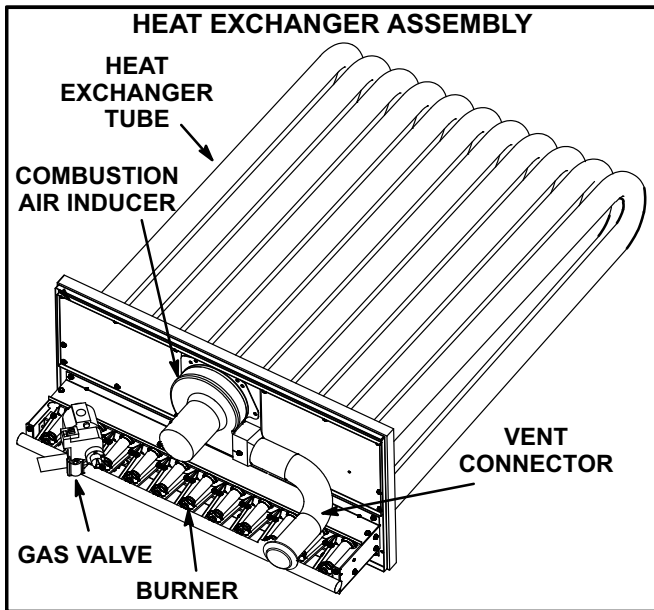

**FIGURE 33**

**E-Flue Passageway and Flue Box (Gas Units)**

- 1- Remove combustion air inducer assembly as described in section D.
- 2- Remove flue box cover. Clean with a wire brush as required.
- 3- Remove inserts if installed. See figure 34.
- 4- Clean tubes with a wire brush.
- 5- Reassemble the unit. The flue box cover gasket and combustion air inducer gasket should also be replaced during reassembly.

**F-Gas Heat Exchanger Inserts**

Inserts are installed on standard (130,000Btuh) heat exchangers. Medium and high heat exchangers do not require inserts. See figure 34.

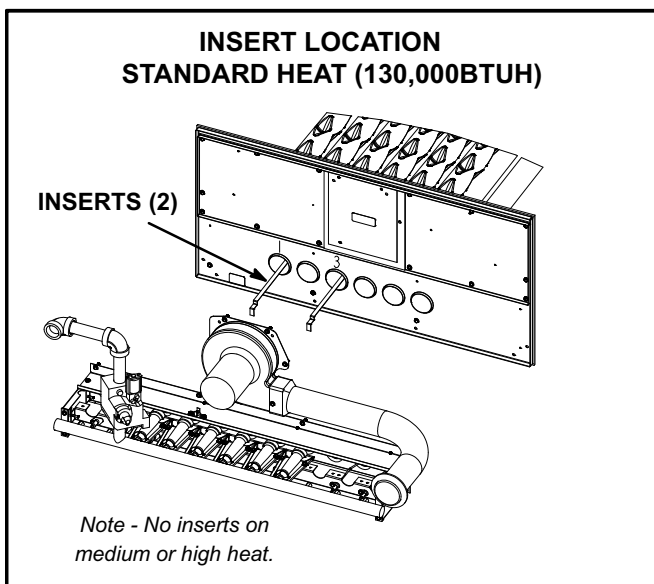

**FIGURE 34**

**G-Evaporator Coil**

Inspect and clean coil at beginning of each cooling season. Clean using mild detergent or commercial coil cleaner. Flush coil and condensate drain with water taking care not to get insulation, filters and return air ducts wet.

**H-Supply Air Blower Wheel**

Annually inspect supply air blower wheel for accumulated dirt or dust. Turn off power before attempting to remove access panel or to clean blower wheel.

**J-Condenser Coil**

Clean condenser coil annually with detergent or commercial coil cleaner and inspect monthly during the cooling season. Access panels are provided on front and back of condenser section.

**K-Needlepoint Bipolar Ionizer**

The ionizer was designed for low maintenance. The device should be checked semi-annually to confirm the brushes are clean for maximum output. The ionizer is located on the blower deck. See figure 35.

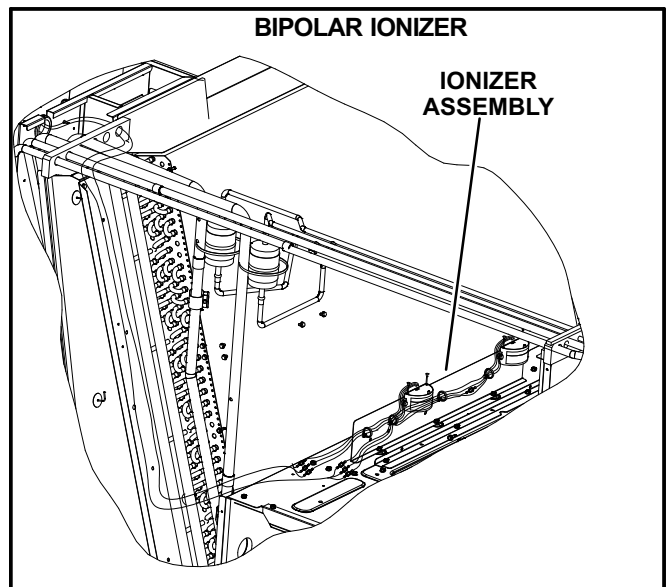

**FIGURE 35**

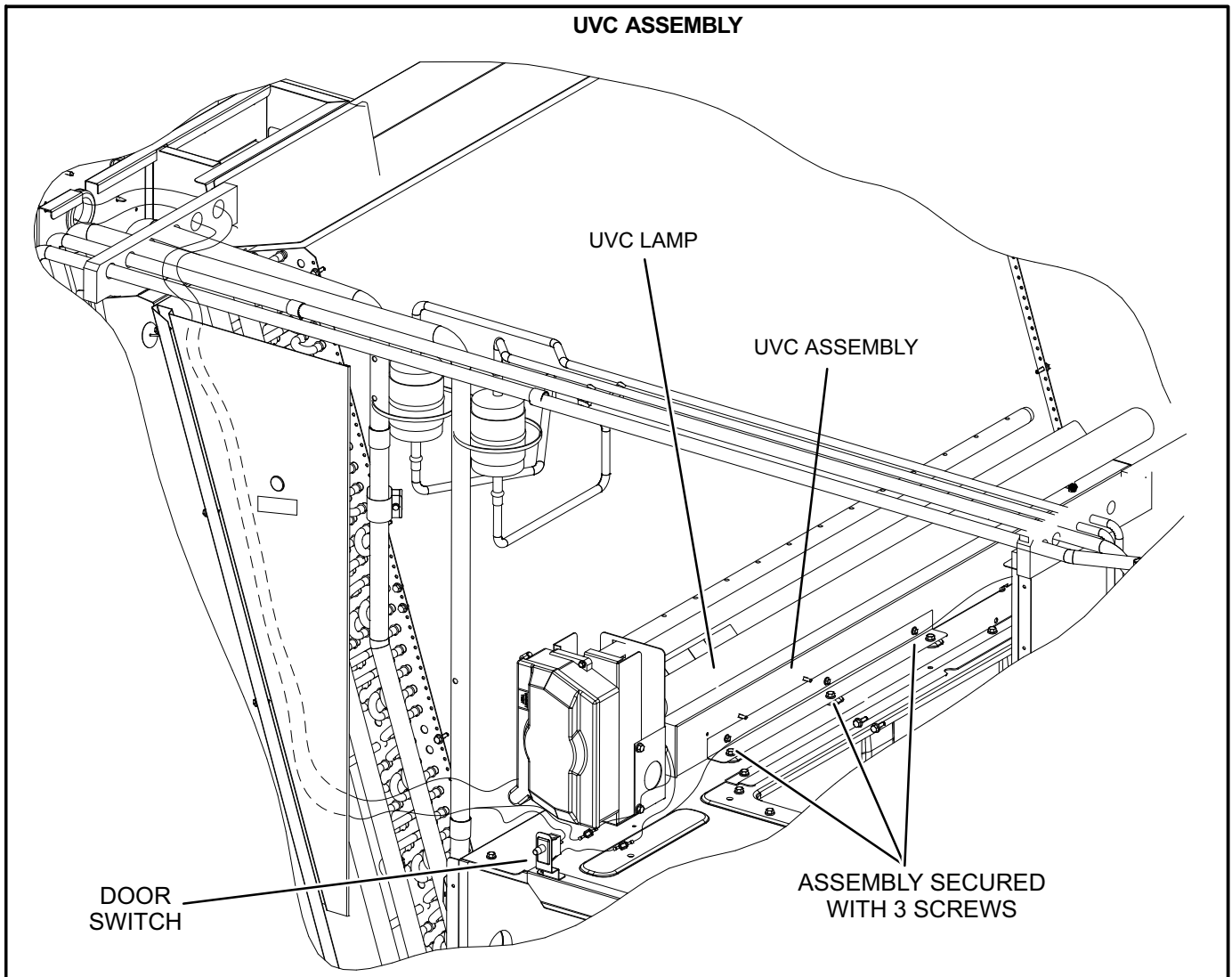

FIGURE 36

### K-UVC Light

When field-installed, use only UVC Light Kit assembly 106882-01 (21A93) with this appliance.

#### Factory-Installed UVC Light

When the UVC light is factory installed, the lamp is shipped in a foam sleeve. The lamp is attached to the UVC light assembly on the blower deck. See figure 36. Remove the lamp and install into the UVC light assembly as shown in steps 2 through 11.

### Annual Lamp Replacement

## **⚠️ WARNING**

**Personal Burn Hazard.**

**Personal injury may result from hot lamps. During replacement, allow lamp to cool for 10 minutes before removing lamp from fixture.**

The lamp should be replaced every 12 months, as UVC energy production diminishes over time.

- 1- Obtain replacement lamp 101087-01 for your germicidal light model.
- 2- Disconnect power to the rooftop unit before servicing the UVC kit.

- 3- Open the blower access door.
- 4- Remove the screw in wire tie from the UVC assembly and disconnect the 4-pin connector from the lamp end.
- 5- Remove and retain the (3) screws securing the UVC assembly. Carefully slide the complete UVC assembly out through the blower access door. See figure 36.

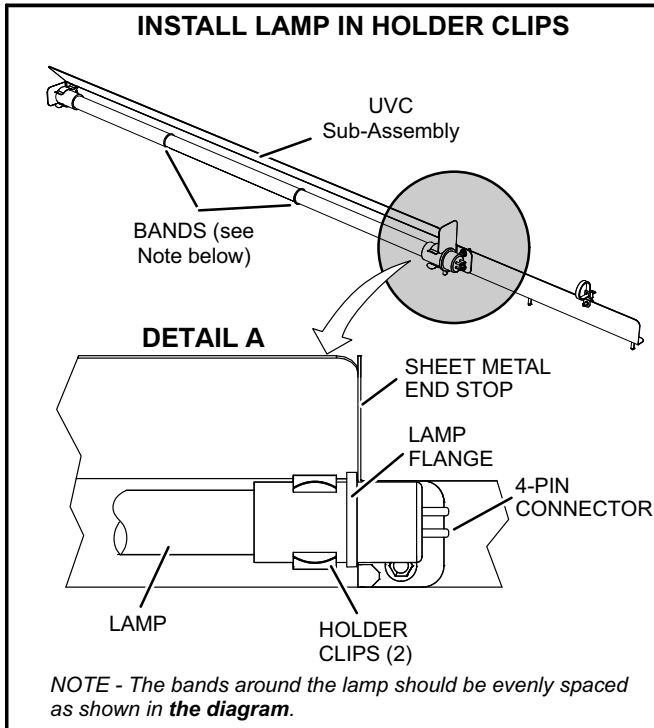

**FIGURE 37**

- 6- Allow 10 minutes before touching the lamps. Then, carefully remove the old lamp from the lamp holder clips.
- 7- Wear cotton gloves or use a cotton cloth when handling the new lamp. Place the new lamp in the holder clips of the UVC assembly. Verify that the lamp flange at the connector end is sandwiched between the lamp holder clip and the sheet-metal end stop (see figure 37).
- 8- Carefully place the UVC assembly on the blower deck. Line up the mounting holes on the UVC assembly with the mounting holes on the blower deck. See figure 36. Use the retained screws provided to attach the UVC assembly in place.
- 9- Close the blower access door.
- 10- Reconnect power to the rooftop unit.
- 11- Open the filter access door and look through the view port in the triangular sheet-metal panel to verify that the UVC light is on.

If UVC lamp does not come on:

- 1- Check Power Wiring: Disconnect 1/4" QC (quick connects) of the UVC cable near the UVC assembly. With Power ON, use multimeter to test 110-230V at the 1/4"QC quick connects from the control panel.
- 2- Check Lamp: Carefully remove the UVC assembly out of the rooftop unit. Use multimeter to test for continuity across each pair of pins at each end of the lamp.
- 3- Check Lamp Installation: Make sure that lamp's pins snap properly into the lamp holder.

LED(s) not illuminated

*Power status LED not lit*—Check that the lamp unit is connected to the proper power source and is wired correctly.

*Lamp status LED(s) not lit*—

- 1- Check that lamp 4-pin connectors are properly engaged.
- 2- Ohm-check across the lamp pins to check for continuity of lamp filaments (see figure 39).

Troubleshooting charts are provided to aid in determining the cause of any problems encountered (figures 38 and 39).

### Lamp Disposal

**Hg-LAMP Contains Mercury.**—Manage in accordance with local, state and federal disposal laws. Refer to [www.lamprecycle.org](http://www.lamprecycle.org) or call 800-953-6669.

### Proper Clean-up Technique in Case of Lamp Breakage

Wear protective gloves, eye wear and mask.

Sweep the broken glass and debris into a plastic bag, seal the bag, and dispose of properly. Contact your local waste management office for proper disposal.

**Do not use a vacuum cleaner. Do not incinerate.**

### Maintenance

- For all maintenance, contact a qualified HVAC technician.
- Read the maintenance instructions before opening unit panels.
- Unintended use of the unit or damage to the unit housing may result in the escape of dangerous UVC radiation. UVC radiation may, even in small doses, cause harm to the eyes and skin.
- Do not operate units that are obviously damaged.
- Do not discard the triangular UVC light shield or any barriers with an ultraviolet radiation symbol.
- Do not override the door interlock switch that interrupts power to the UVC light.
- Do not operate the UVC light outside of the unit.

# ⚠ DANGER

**Ultraviolet (UVC) Radiation hazard.**  
**Any exposure will cause significant eye damage and may cause skin damage.**  
**DO NOT look into UVC light source.**  
**Access panels must be in place during appliance operation.**

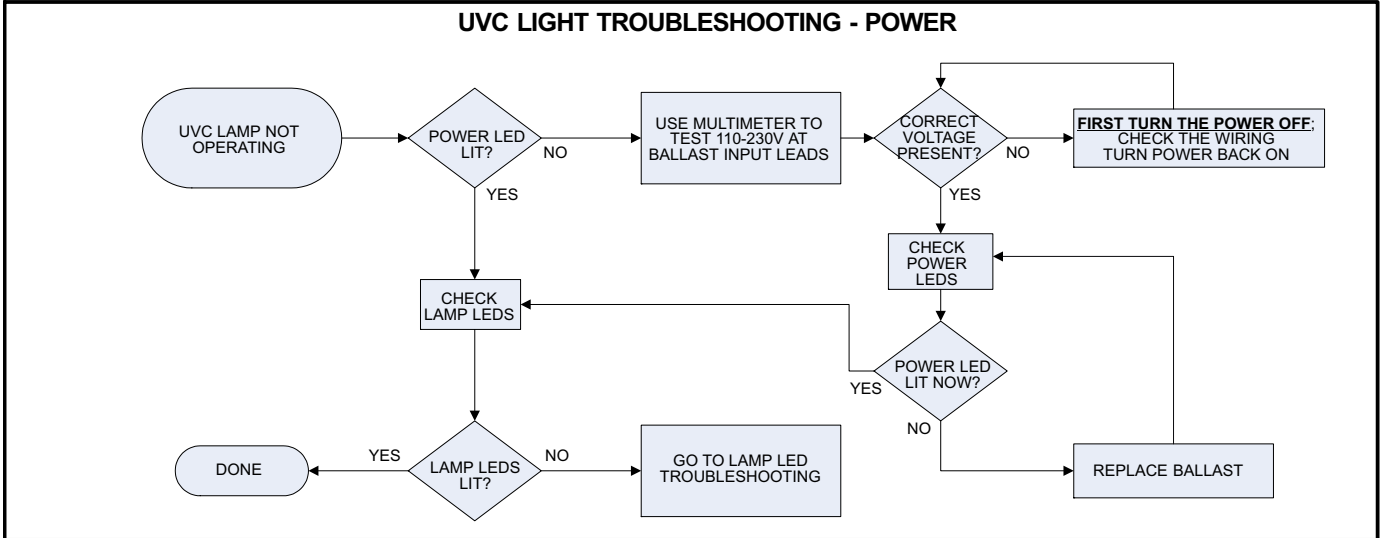

FIGURE 38

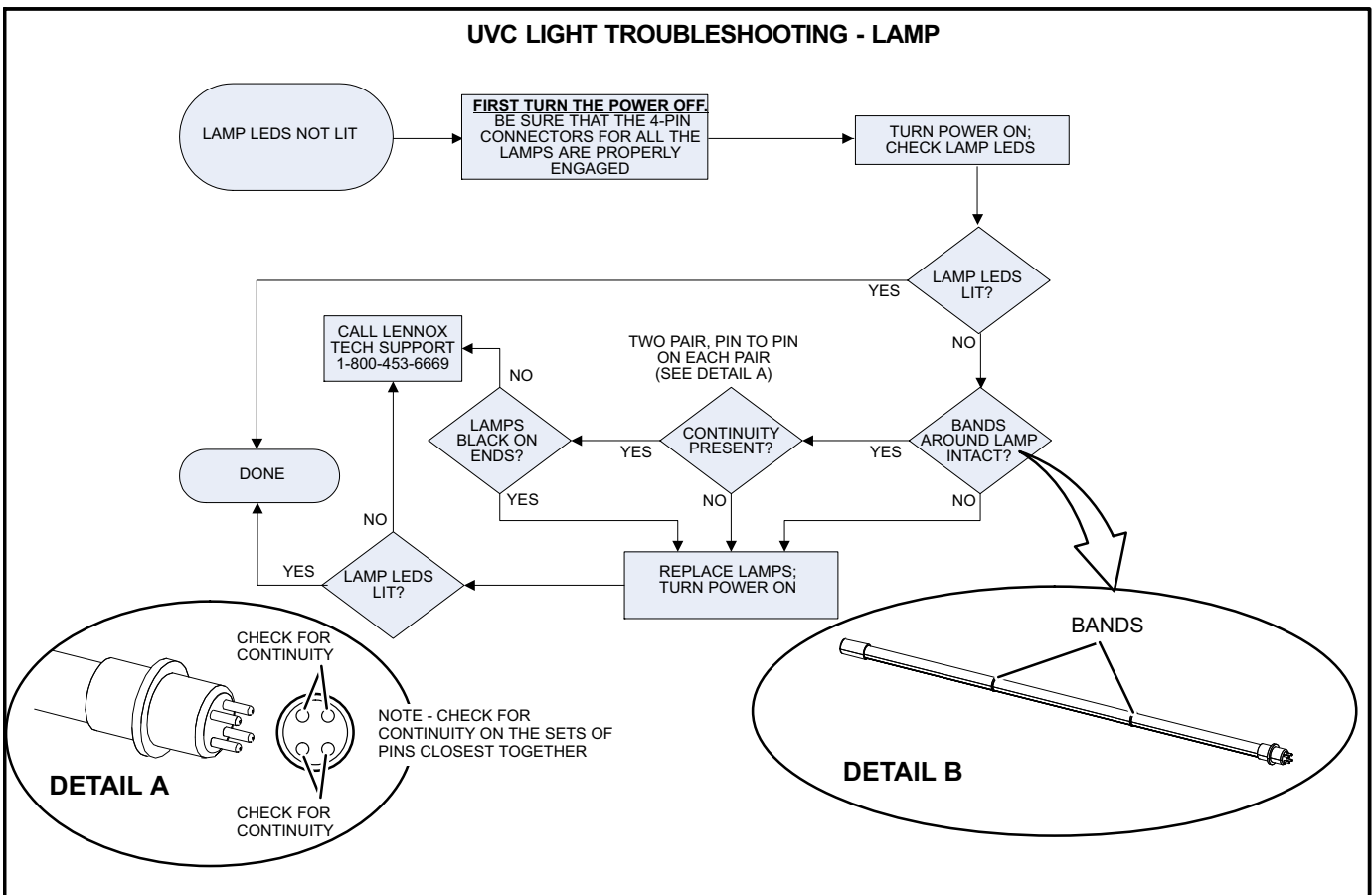

FIGURE 39

### Field-Installed Accessories

When field-installing the following accessories, refer to the latest online installation instruction.

**TABLE 11**

Accessory	Instruction #
Economizer	507227-XX
Outdoor Air Damper	506340-XX
Electric Heat	507250-XX
Smoke Detector	506437-XX

### Factory Unit Controller Settings

Use the mobile service app to adjust parameters; menu paths are shown in each table. Refer to the Unit Controller manual provided with each unit.

Tables 12 through 14 show control options. When applicable, record field-specific information on the label located inside the compressor access panel.

When field installing optional kits and accessories, the Unit Controller must be configured to identify the option before it will function. Refer to figures 40 and 41 to determine whether the Unit Controller configuration I.D. must change. To configure the option, use RTU MENU > SETUP > INSTALL menu path. Press NEXT until CONFIGURATION ID 1 or 2 appears depending on the option installed. Change the appropriate character in the configuration I.D. For example, when an economizer is installed using a single enthalpy sensor, change configuration I.D. 1, the second character, to “S”.

**TABLE 12**  
**581024-01**

Units With Hot Gas Reheat			
RTU Menu > Settings “RTU Options” > Dehumidifier			
Parameter	Factory Setting	Field Setting	Description
105	7		Factory Setting 7: Reheat mode enabled without prerequisite conditions. Controlled by RH sensor (A91) connected to input A55_P298_5 and set point set at parameter 106 (default 60%).

**TABLE 13**  
**581037-01**

Units With LonTalk Settings
Use menu RTU Menu > Network Integration > Network Setup Wizard > Set “LONTALK”

**TABLE 14**  
**581038-01**

Units With BACnet Settings
RTU Menu > Network Integration > Network Setup Wizard > BACnet MS/TP > See BACnet MAC Address
BACNET MAC ADDRESS:
Units With Room Sensor, CPC/LSE Gateway Settings
RTU Menu > Network Integration > Network Setup Wizard > SBUS > Set SBUS Address
LCONN ADDRESS:

# Configuration ID 1

1 2 3 4 5 6 7 8

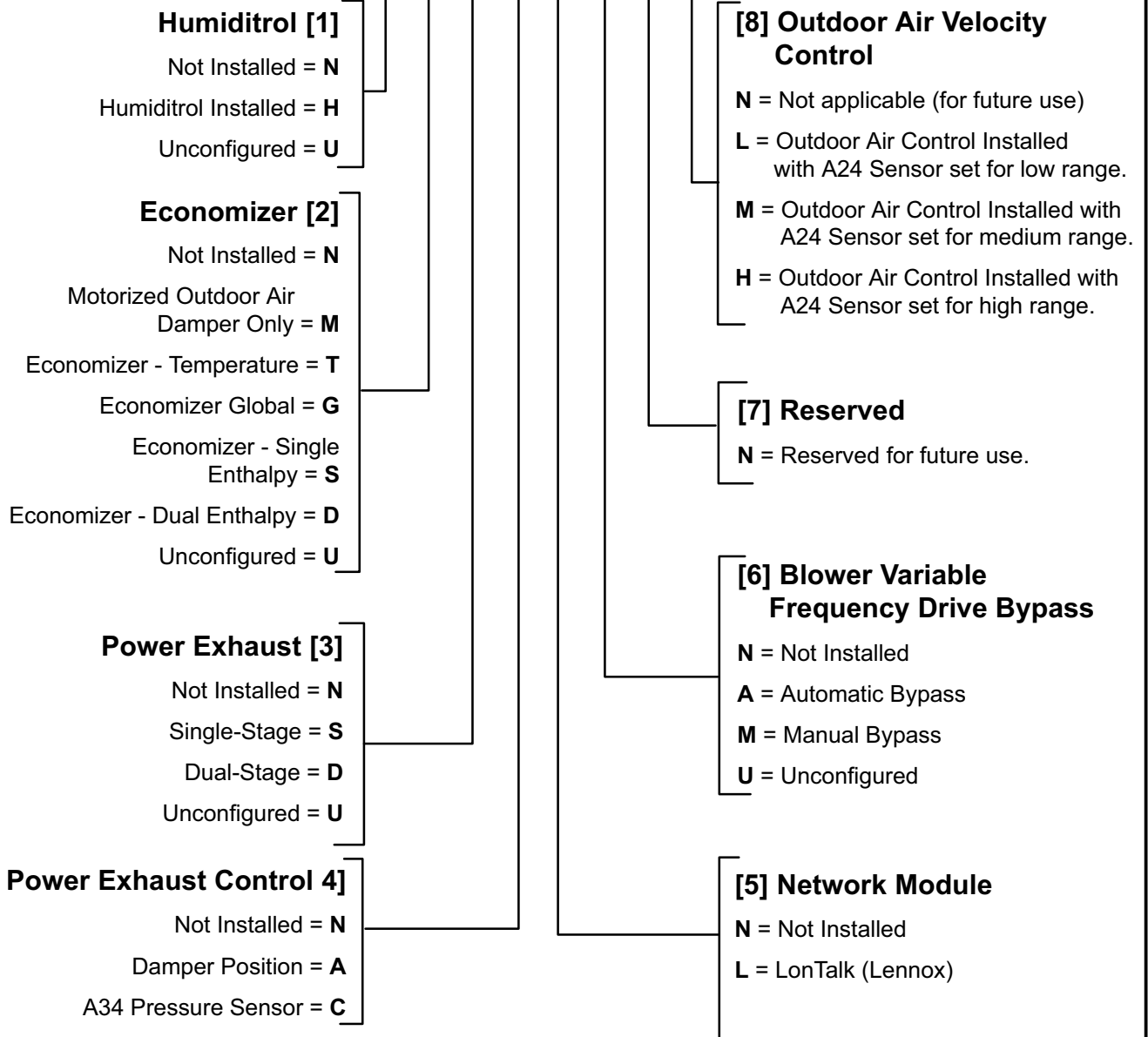
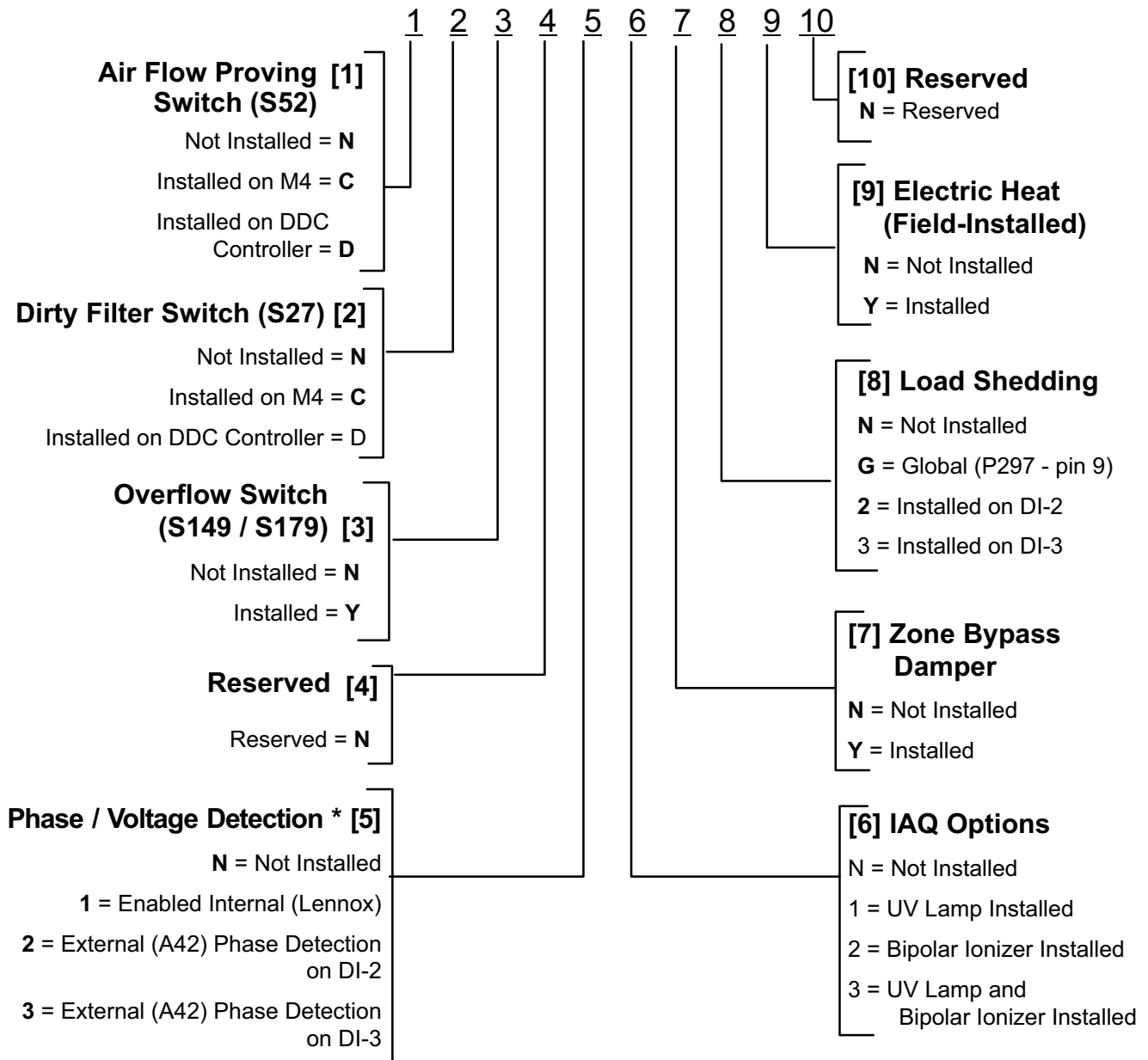

FIGURE 40

## Configuration ID 2



\* When phase detection and voltage monitoring is enabled and wired incorrectly, the system will go into demand hold status and restart after six minutes.

**FIGURE 41**

## START-UP REPORT

Job Name: \_\_\_\_\_  
 Store No. \_\_\_\_\_ Start-Up Date: \_\_\_\_\_  
 Address: \_\_\_\_\_  
 City: \_\_\_\_\_ State: \_\_\_\_\_  
 Start-Up Contractor: \_\_\_\_\_  
 Technician: \_\_\_\_\_  
 Model No.: \_\_\_\_\_  
 Serial No.: \_\_\_\_\_  
 RTU No.: \_\_\_\_\_ Catalog No.: \_\_\_\_\_

Inspections and Checks			
Damage?	Yes	No	R22 <input type="checkbox"/> R410A <input type="checkbox"/>
If yes, reported to: _____			
Verify factory and field-installed accessories.			
Check electrical connections. Tighten if necessary.			
Supply voltage: L1-L2 _____ L1-L3 _____ L2-L3 _____			
If unit contains a 208-230/240 volt transformer:			
Check primary transformer tap <input type="checkbox"/>			
Transformer secondary voltage: _____			

Cooling Checks												
Compressor Rotation <input type="checkbox"/> Ambient Temp. _____ Return Air Temp. _____ Supply Air Temp. _____												
	Compressor Amps			Compressor Volts			Pressures		Condenser Fan Amps			CC Heater Amps
	L1	L2	L3	L1-L2	L1-L3	L2-L3	Disch.	Suct.	L1	L2	L3	L1
1												
2												
3												
4												

Blower Checks			
Pulley/Belt Alignment	<input type="checkbox"/>	Blower Rotation	<input type="checkbox"/>
Set Screws Tight	<input type="checkbox"/>	Belt Tension	<input type="checkbox"/>
Nameplate Amps: _____		Volts: _____	
Motor	Amps	Volts	
	L1 _____	L1-L2 _____	
	L2 _____	L1-L3 _____	
	L3 _____	L2-L3 _____	

Heating Checks - Electric							
Return Air Temp.: _____ Supply Air Temp.: _____							
Limits Operate: <input type="checkbox"/>							
	Amps						
	L1	L2	L3		L1	L2	L3
1				10			
2				11			
3				12			
4				13			
5				14			
6				15			
7				16			
8				17			
9				18			

Heating Checks - Gas		
Fuel type: Nat. <input type="checkbox"/> LP <input type="checkbox"/> Inlet Pressure: _____ in. w.c.		
Return Air Temp.: _____ Supply Air Temp.: _____		
Altitude: _____ Primary Limits Operate: <input type="checkbox"/>		
CO2%: _____		
Gas Valve	Manifold Pressure	
	Low Fire	High Fire
GV1		
GV2		

Accessory Checks	
Power Exhaust Amps	
1 _____	2 _____ None <input type="checkbox"/>
Economizer Operation	
Min. Pos. <input type="checkbox"/>	Motor travel full open/close <input type="checkbox"/>

Control Type