

FEATURES

- Completely self-contained heating and cooling package
 - No outside condensing unit
 - No external refrigerant lines
 - No separate cooling coil
- Pre-wired and pre-charged
- Individually metered and controlled
- Slide-out cooling chassis

REFRIGERANT SYSTEM

- R410a Refrigerant
- High efficiency compressor
- Copper tubing with enhanced fin coils

CABINET

- Attractive, neutral-toned finish

BLOWER

- Multispeed motor for wide airflow range
- PSC permanently lubricated motor for low maintenance and maximum efficiency
- Dynamically balanced blower with resilient motor mounts for smooth and quiet operation
- Internal washable filter

CONTROLS

- Color coded wiring for easy service

INSTALLATION

- Easy to install and service

WARRANTY

- 5 year limited warranty on all parts

EWC4 Model Vintage™ Units Electric Heating / Electric Cooling Packaged Thru-the-Wall Units



Model Number Guide

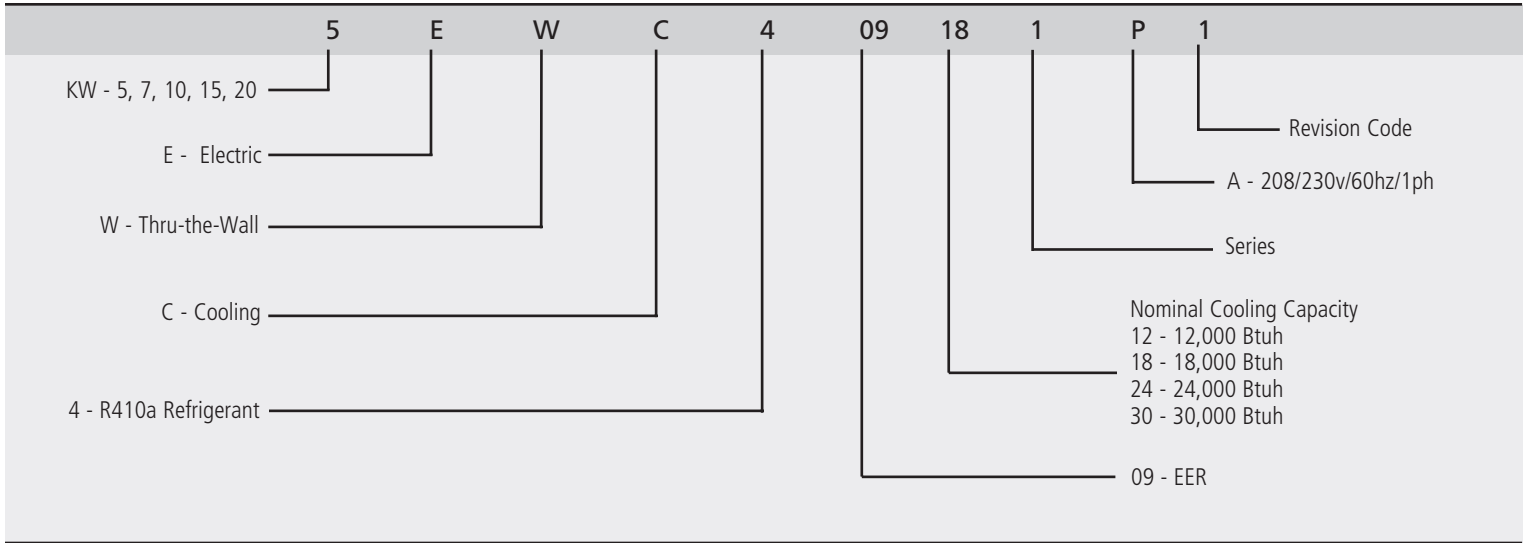

Electrical and Physical Data

Model	Voltage/ Hz/ Phase	Voltage Range	Min. Circuit Ampacity				Maximum Fuse Size				Compressor		Outside Fan				Indoor Blower			Refrig. Charge (oz.)	Weight (lbs)
			Ckt.1		Ckt.2		Ckt. 1		Ckt. 2		Rated Load Amps	Locked Rotor Amps	Dia.	Nom. RPM	Rated Load Amps	Rated HP	Wheel dia. x wid. (in.)	Rated Load Amps	Rated HP		
			208V	230V	208V	230V	208V	230V	208V	230V											
			208V	230V	208V	230V	208V	230V	208V	230V											
5EWC4-09-121	208-230/60/1	197 - 253	25	28	-	-	25	30	NA	NA	4.5	45.0	18	1075	0.90	1/8	10 x 4	1.1	1/6	39	325
10EWC4-09-121			45	53	-	-	45	60	NA	NA											
5EWC4-09-181	208-230/60/1	197 - 253	25	28	-	-	25	30	NA	NA	9.0	48.0	18	1075	0.90	1/8	10 x 4	2.2	1/3	43	350
7EWC4-09-181			36	41	-	-	35	40	NA	NA											
10EWC4-09-181			47	53	-	-	50	60	NA	NA											
15EWC4-09-181			25	28	44	50	25	30	50	60											
5EWC4-09-241	208-230/60/1	197 - 253	25	28	-	-	25	30	NA	NA	13.5	58.3	18	1075	1.60	1/4	10 x 4	2.2	1/3	52	360
7EWC4-09-241			36	41	-	-	35	40	NA	NA											
10EWC4-09-241			47	53	-	-	50	60	NA	NA											
15EWC4-09-241			25	28	44	50	25	30	50	60											
20EWC4-09-241			47	53	44	50	50	60	50	60											
10EWC4-09-301	208-230/60/1	197 - 253	47	53	-	-	50	60	NA	NA	13.1	74.0	18	1075	1.60	1/4	10 x 4	2.2	1/3	80	380
15EWC4-09-301			25	28	44	50	25	30	50	60											
20EWC4-09-301			47	53	44	50	50	60	50	60											

Blower Performance

Model	Blower Speed	CFM @ ext. static pressure - in. w.c. with filter			
		0.2	0.3	0.4	0.5
EWC4-09-121	Hi	650	615	575	540
	Med	475	450	425	400
	Low	415	405	390	380
EWC4-09-181, 241, 301	Hi	875	825	775	725
	Med	850	805	760	710
	Low	630	605	575	550

Performance

Model	Cooling				Heating			
	Btuh	EER	S/T	CFM	@240V		@208V	
					kW/Hr	Btu/Hr	kW/Hr	Btu/Hr
5EWC4-09-121	11,400	9.0	.72	400	4.8	16,300	3.6	12,300
10EWC4-09-121					9.6	32,700	7.2	24,600
5EWC4-09-181	17,000	9.0	.74	650	4.8	16,300	3.6	12,300
7EWC4-09-181					7.2	24,600	5.4	18,400
10EWC4-09-181					9.6	32,700	7.2	24,600
15EWC4-09-181					14.4	49,100	10.8	36,900
5EWC4-09-241	22,000	9.0	.74	800	4.8	16,300	3.6	12,300
7EWC4-09-241					7.2	24,600	5.4	18,400
10EWC4-09-241					9.6	32,700	7.2	24,600
51EWC4-09-241					14.4	49,100	10.8	36,900
20EWC4-09-241					19.2	65,500	14.4	49,200
10EWC4-09-301	27,600	9.0	.70	875	9.6	32,700	7.2	24,600
15EWC4-09-301					14.4	49,100	10.8	36,900
20EWC4-09-301					19.2	65,500	14.4	49,200

Sound Ratings

Model	Sound Rating (dBA)
5EWC4-09-121P	76
10EWC4-09-121P	
5EWC4-09-181P	76
7EWC4-09-181P	
10EWC4-09-181P	
15EWC4-09-181P	
5EWC4-09-241P	80
7EWC4-09-241P	
10EWC4-09-241P	
15EWC4-09-241P	
20EWC4-09-241P	
10EWC4-09-301P	80
15EWC4-09-301P	
20EWC4-09-301P	

Accessories

Description	Kit Number	Where Used
Wall Sleeve	CA-239	All EWC4's
Decorative External Louver	ALVR42-1	All EWC4's
Chassis Adapter Kit	ADAPT420	All EWC4's
Wall Sleeve Adapter Kit	A242	All EWC4's
Low Ambient Kit	ALOAMB505-1	All EWC4's

Dimensions (in.)

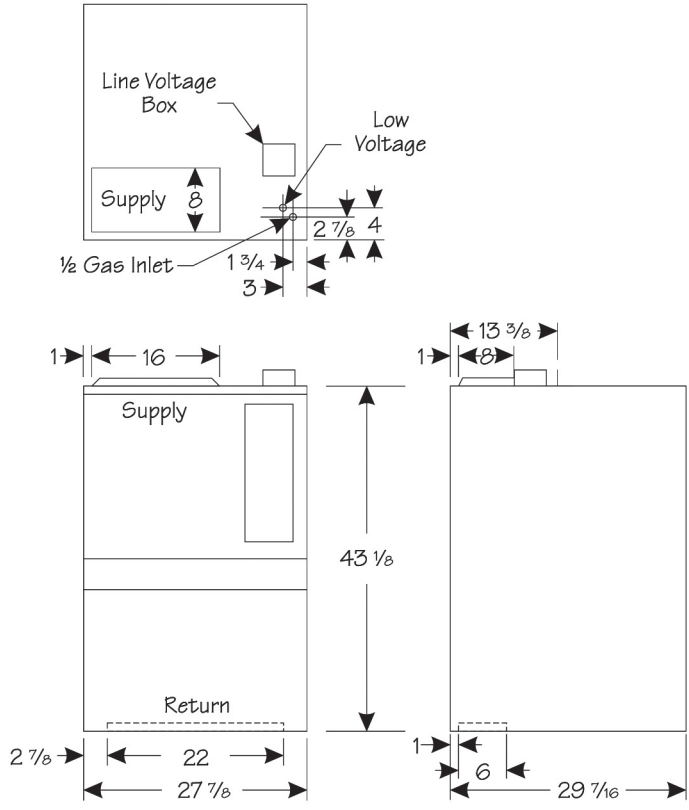

Wall Sleeve (in.)

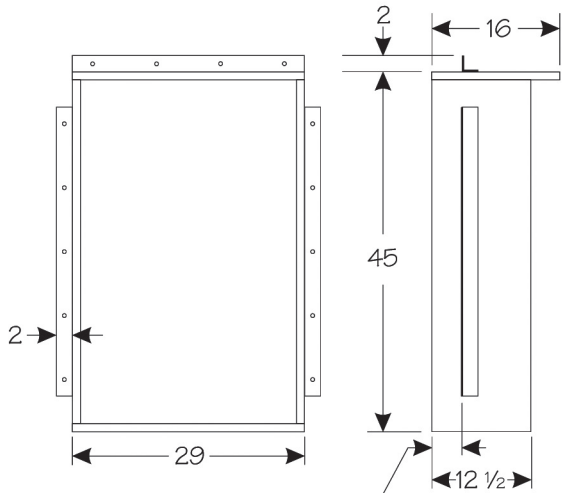

Flange may be assembled
1" or 3 3/4" from front of sleeve



215 Metropolitan Drive
West Columbia, SC 29170
800-448-5872
Product Support 866-282-7257

All specifications and illustrations
subject to change without notice
and without incurring obligations.