



Service Manual

MODEL: GWC09MB-D3DNA3D GWH09MB-D3DNA3D
GWC12MB-D3DNA3D GWH12MB-D3DNA3D
GWC18MC-D3DNA3D GWH18MC-D3DNA3D
GWC24MD-D3DNA3D GWH24MD-D3DNA3D
GWH09MB-D3DNA4D GWC18MC-D3DNA4D
GWH18MC-D3DNA4D GWC24MD-D3DNA4D
GWH24MD-D3DNA4D GWC18MC-D3DNA5D
GWH18MC-D3DNA5D GWC24MD-D3DNA5D
GWH24MD-D3DNA5D GWC18MC-D3DNA8D
GWH18MC-D3DNA8D GWC24MD-D3DNA8D
GWH24MD-D3DNA8D GWC18MC-D3DNC1D
GWC24MD-D3DNC1D GWC18MC-D3DND3D
GWH18MC-D3DND3D GWC24MD-D3DND3D
GWH24MD-D3DND3D GWC18MC-D3DNE3D
GWC24MD-D3DNE3D (Refrigerant R410A)

Table of Contents

Summary and Features	1
1. Safety Precautions	4
2. Specifications	5
2.1 Unit Specifications	5
2.2 Operation Characteristic Curve	17
2.3 Capacity Variation Ratio According to Temperature	18
2.4 Noise Criteria Curve Tables for Both Models	19
2.5 Operation Data	20
3. Construction Views	21
3.1 Indoor Unit	21
3.2 Outdoor Unit	22
4. Refrigerant System Diagram	24
5. Schematic Diagram	25
5.1 Electrical Data	25
5.2 Electrical Wiring	25
5.3 Printed Circuit Board	31
6. Function and Control	37
6.1 Remote Control Operations	37
6.2 Description of Each Control Operation	40
7. Installation Manual	54
7.1 Notices for Installation	54
7.2 Installation Drawing	56
7.3 Install Indoor Unit	57
7.4 Install Outdoor Unit	58

7.5 Check after Installation and Operation Test	59
7.6 Installation and Maintenance of Healthy Filter	60
8. Exploded Views and Parts List	61
8.1 Indoor Unit.....	61
8.2 Outdoor Unit.....	81
9. Troubleshooting	105
9.1 Malfunction Analysis.....	105
9.2 Flashing LED of Indoor/Outdoor Unit and Primary Judgement.....	109
9.3 How to Check Simply the Main Part.....	122
10. Removal Procedure.....	144
10.1 Removal Procedure of Indoor Unit.....	144
10.2 Removal Procedure of Outdoor Unit(09K)	147
10.3 Removal Procedure of Outdoor Unit(12K)	151
10.4 Removal Procedure of Outdoor Unit(18K)	155
10.5 Removal Procedure of Outdoor Unit(24K)	160

Summary and Features

Indoor Unit

GWC09MB-D3DNA3D/I
GWH09MB-D3DNA3D/I
GWC12MB-D3DNA3D/I
GWH12MB-D3DNA3D/I
GWC18MC-D3DNA3D/I
GWH18MC-D3DNA3D/I
GWC24MD-D3DNA3D/I
GWH24MD-D3DNA3D/I

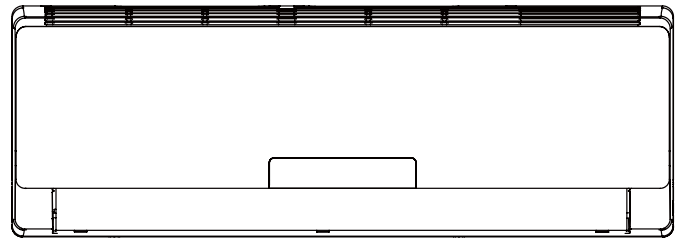

GWH09MB-D3DNA4D/I
GWC18MC-D3DNA4D/I
GWH18MC-D3DNA4D/I
GWC24MD-D3DNA4D/I
GWH24MD-D3DNA4D/I

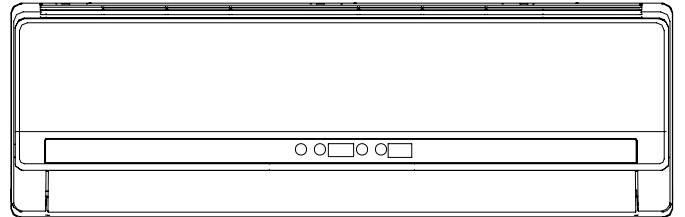

GWC18MC-D3DNA5D/I
GWH18MC-D3DNA5D/I
GWC24MD-D3DNA5D/I
GWH24MD-D3DNA5D/I

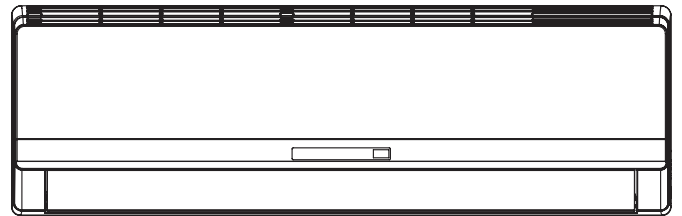

GWC18MC-D3DNA8D/I
GWH18MC-D3DNA8D/I
GWC24MD-D3DNA8D/I
GWH24MD-D3DNA8D/I

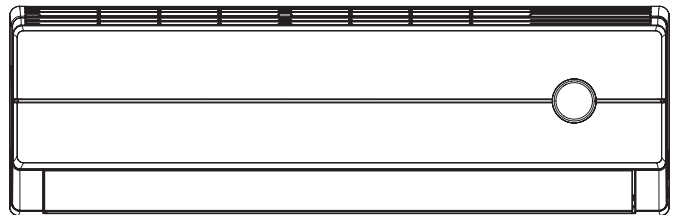

GWC18MC-D3DNC1D/I
GWC24MD-D3DNC1D/I

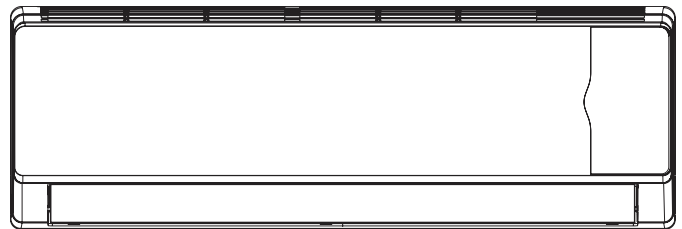

GWC18MC-D3DND3D/I
GWH18MC-D3DND3D/I
GWC24MD-D3DND3D/I
GWH24MD-D3DND3D/I

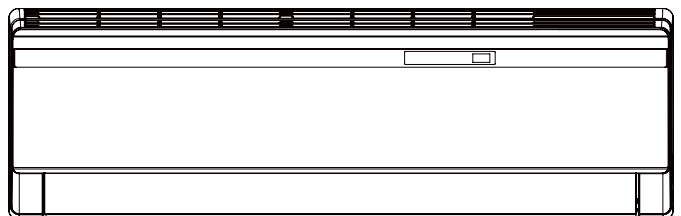

GWC18MC-D3DNE3D/I
GWC24MD-D3DNE3D/I

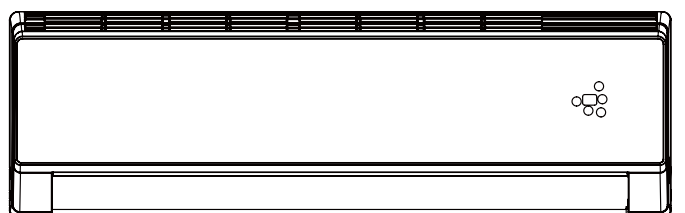

Outdoor Unit

GWC09MB-D3DNA3D/O
GWH09MB-D3DNA3D/O
GWH09MB-D3DNA3D/O(electric heating belt)

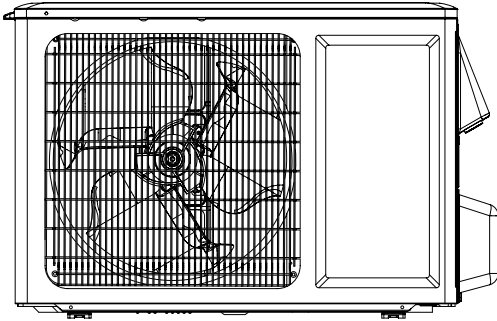

GWC12MB-D3DNA3D/O
GWH12MB-D3DNA3D/O
GWH12MB-D3DNA3D/O(electric heating belt)

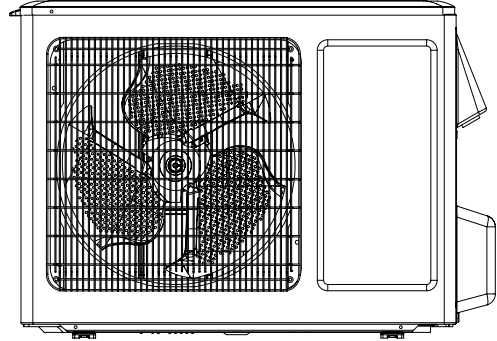

GWC18MC-D3DNA3D/O
GWH18MC-D3DNA3D/O
GWH18MC-D3DNA3D/O(electric heating band)

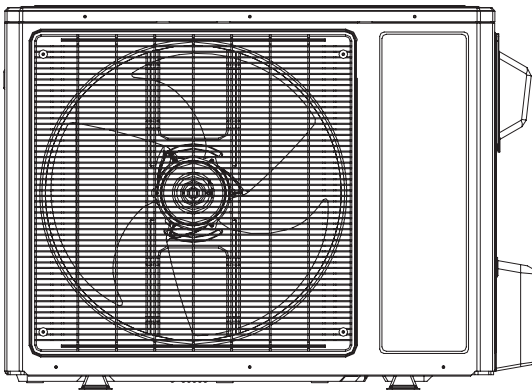

GWC24MD-D3DNA3D/O
GWH24MD-D3DNA3D/O
GWH24MD-D3DNA3D/O(electric heating band)

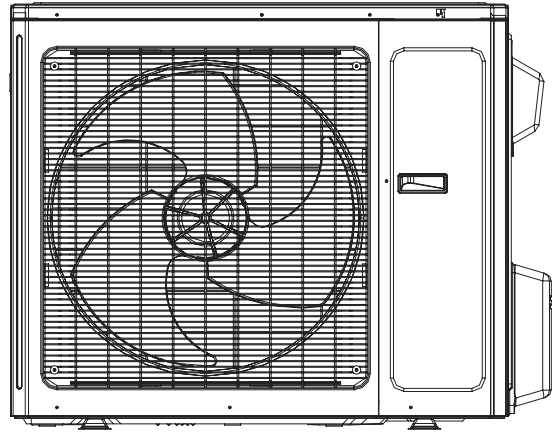

Remote Controller

YB1FAF



Summary and Features

Model list

NO.	Model	Product code	Indoor model	Indoor product code	Outdoor model	Outdoor product code
1	GWC09MB-D3DNA3D	CB171006600	GWC09MB-D3DNA3D/I	CB171N06600	GWC09MB-D3DNA3D/O	CB171W06600
2	GWC12MB-D3DNA3D	CB171006700	GWC12MB-D3DNA3D/I	CB171N06700	GWC12MB-D3DNA3D/O	CB171W06700
3	GWH09MB-D3DNA3D (electric heating band)	CB171004501	GWH09MB-D3DNA3D/I	CB171N04500	GWH09MB-D3DNA3D/O (electric heating band)	CB171W04501
4	GWH09MB-D3DNA3D	CB171004500			GWH09MB-D3DNA3D/O	CB171W04500
5	GWH09MB-D3DNA4D	CB161004800	GWH09MB-D3DNA4D/I	CB161N04800	GWH12MB-D3DNA3D/O	CB171W04600
6	GWH12MB-D3DNA3D	CB171004600	GWH12MB-D3DNA3D/I	CB171N04600		
7	GWH12MB-D3DNA3D (electric heating band)	CB171004601			GWH12MB-D3DNA3D/O (electric heating band)	CB171W04601
8	GWC18MC-D3DNA3D	CB171006800	GWC18MC-D3DNA3D/I	CB171N06800	GWC18MC-D3DNA3D/O	CB171W06800
9	GWC18MC-D3DNA4D	CB161005100	GWC18MC-D3DNA4D/I	CB161N05100		
10	GWC18MC-D3DNA5D	CB162005300	GWC18MC-D3DNA5D/I	CB162N05300		
11	GWC18MC-D3DNA8D	CB173003600	GWC18MC-D3DNA8D/I	CB173N03600		
12	GWC18MC-D3DNC1D	CB139004300	GWC18MC-D3DNC1D/I	CB139N04300		
13	GWC18MC-D3DND3D	CB405001600	GWC18MC-D3DND3D/I	CB405N01600		
14	GWC18MC-D3DNE3D	CB404001100	GWC18MC-D3DNE3D/I	CB404N01100		
15	GWH18MC-D3DNA3D (electric heating band)	CB171004701	GWH18MC-D3DNA3D/I	CB171N04700		
16	GWH18MC-D3DNA3D	CB171004700			GWH18MC-D3DNA3D/O	CB171W04700
17	GWH18MC-D3DNA4D	CB161005200	GWH18MC-D3DNA4D/I	CB161N05200		
18	GWH18MC-D3DNA5D	CB162005400	GWH18MC-D3DNA5D/I	CB162N05400		
19	GWH18MC-D3DNA8D	CB173003700	GWH18MC-D3DNA8D/I	CB173N03700		
20	GWH18MC-D3DND3D	CB405001700	GWH18MC-D3DND3D/I	CB405N01700		
21	GWC24MD-D3DNA3D	CB171006900	GWC24MD-D3DNA3D/I	CB171N06900		
22	GWC24MD-D3DNA4D	CB161004500	GWC24MD-D3DNA4D/I	CB161N04500		
23	GWC24MD-D3DNA5D	CB162005000	GWC24MD-D3DNA5D/I	CB162N05000		
24	GWC24MD-D3DNA8D	CB173003800	GWC24MD-D3DNA8D/I	CB173N03800		
25	GWC24MD-D3DNC1D	CB139004400	GWC24MD-D3DNC1D/I	CB139N04400		
26	GWC24MD-D3DND3D	CB405001800	GWC24MD-D3DND3D/I	CB405N01800		
27	GWC24MD-D3DNE3D	CB404001200	GWC24MD-D3DNE3D/I	CB404N01200		
28	GWH24MD-D3DNA3D (electric heating band)	CB171007001	GWH24MD-D3DNA3D/I	CB171N07000	GWH24MD-D3DNA3D/O (electric heating band)	CB171W07001
29	GWH24MD-D3DNA3D	CB171007000			GWH24MD-D3DNA3D/O	CB171W07000
30	GWH24MD-D3DNA4D	CB161004600	GWH24MD-D3DNA4D/I	CB161N04600		
31	GWH24MD-D3DNA5D	CB162005100	GWH24MD-D3DNA5D/I	CB162N05100		
32	GWH24MD-D3DNA8D	CB173003900	GWH24MD-D3DNA8D/I	CB173N03900		
33	GWH24MD-D3DND3D	CB405001900	GWH24MD-D3DND3D/I	CB405N01900		

1. Safety Precautions

Installing, starting up, and servicing air conditioner can be hazardous due to system pressure, electrical components, and equipment location, etc.

Only trained, qualified installers and service personnel are allowed to install, start-up, and service this equipment.

Untrained personnel can perform basic maintenance functions such as cleaning coils. All other operations should be performed by trained service personnel.

When handling the equipment, observe precautions in the manual and on tags, stickers, and labels attached to the equipment. Follow all safety codes. Wear safety glasses and work gloves. Keep quenching cloth and fire extinguisher nearby when brazing.

Read the instructions thoroughly and follow all warnings or cautions in literature and attached to the unit. Consult local building codes and current editions of national as well as local electrical codes.

Recognize the following safety information:

 **Warning** Incorrect handling could result in personal injury or death.

 **Caution** Incorrect handling may result in minor injury, or damage to product or property.

 **Warning**

All electric work must be performed by a licensed technician according to local regulations and the instructions given in this manual.

- Before installing, modifying, or servicing system, main electrical disconnect switch must be in the OFF position. There may be more than 1 disconnect switch. Lock out and tag switch with a suitable warning label.
- Never supply power to the unit unless all wiring and tubing are completed, reconnected and checked.
- This system adopts highly dangerous electrical voltage. Incorrect connection or inadequate grounding can cause personal injury or death. Stick to the wiring diagram and all the instructions when wiring.
- Have the unit adequately grounded in accordance with local electrical codes.
- Have all wiring connected tightly. Loose connection may lead to overheating and a possible fire hazard.

All installation or repair work shall be performed by your dealer or a specialized subcontractor as there is the risk of fire, electric shock, explosion or injury.

- Make sure the outdoor unit is installed on a stable, level surface with no accumulation of snow, leaves, or trash beside.
- Make sure the ceiling/wall is strong enough to bear the weight of the unit.
- Make sure the noise of the outdoor unit does not disturb neighbors.
- Follow all the installation instructions to minimize the risk of damage from earthquakes, typhoons or strong winds.
- Avoid contact between refrigerant and fire as it generates poisonous gas.
- Apply specified refrigerant only. Never have it mixed with any other refrigerant. Never have air remain in the refrigerant line as it may lead to rupture and other hazards.
- Make sure no refrigerant gas is leaking out when installation is completed.
- Should there be refrigerant leakage, the density of refrigerant in the air shall in no way exceed its limited value, or it may lead to explosion.
- Keep your fingers and clothing away from any moving parts.
- Clear the site after installation. Make sure no foreign objects are left in the unit.
- Always ensure effective grounding for the unit.

 **Caution**

- Never install the unit in a place where a combustible gas might leak, or it may lead to fire or explosion.
- Make a proper provision against noise when the unit is installed at a telecommunication center or hospital.
- Provide an electric leak breaker when it is installed in a watery place.
- Never wash the unit with water.
- Handle unit transportation with care. The unit should not be carried by only one person if it is more than 20kg.
- Never touch the heat exchanger fins with bare hands.
- Never touch the compressor or refrigerant piping without wearing glove.
- Do not have the unit operate without air filter.
- Should any emergency occur, stop the unit and disconnect the power immediately.
- Properly insulate any tubing running inside the room to prevent the water from damaging the wall.

2. Specifications

2.1 Unit Specifications

Model			GWC09MB-D3DNA3D	GWH09MB-D3DNA3D GWH09MB-D3DNA4D
Product Code			CB171006600	CB171004500 CB161004800
Power Supply	Rated Voltage	V ~	208/230	208/230
	Rated Frequency	Hz	60	60
	Phases		1	1
Power Supply Mode			Outdoor	Outdoor
Cooling Capacity(Min ~ Max)		Btu/h	9000(3500~9600)	9000(3500~9600)
Heating Capacity(Min ~ Max)		Btu/h	/	9800(2200~11000)
Cooling Power Input(Min ~ Max)		W	620(370~1075)	620(370~1075)
Heating Power Input(Min ~ Max)		W	/	750(200~900)
Cooling Current Input		A	2.8	2.8
Heating Current Input		A	/	3.04
Rated Input		W	1430	1430
Rated Current		A	7	7
Air Flow Volume (S/H/M/L)		CFM	306/277/253/218	306/277/253/218
Dehumidifying Volume		Pint/h	2.54	2.54
EER		(Btu/h)/W	14.2	14.2
COP		(Btu/h)/W	/	14
SEER			22	22
HSPF			/	9.2
Application Area		m ²	12-18	12-18
Indoor Unit	Indoor Unit Model		GWC09MB-D3DNA3D/I	GWH09MB-D3DNA3D/I GWH09MB-D3DNA4D/I
	Indoor Unit Product Code		CB171N06600	CB171N04500 CB161N04800
	Fan Type			Cross-flow
	Fan Diameter Length(DXL)		inch	Φ3.6X25.4
	Cooling Speed(S/H/M/L)		r/min	1260/1100/950/750
	Heating Speed(S/H/M/L)		r/min	/
	Fan Motor Power Output		W	20
	Fan Motor RLA		A	0.2
	Fan Motor Capacitor		μF	1
	Evaporator Form		W	Aluminum Fin-copper Tube
	Evaporator Pipe Diameter		inch	Φ0.27
	Evaporator Row-fin Gap		inch	2-0.05
	Evaporator Coil Length (LXD _X W)		inch	22.8X1X10.4
	Swing Motor Model			MP24AA
	Swing Motor Power Output		W	2
	Fuse Current		A	3.15
	Sound Pressure Level (S/H/M/L)		dB (A)	42/38/35/32
	Sound Power Level (S/H/M/L)		dB (A)	52/48/45/42
	Dimension (WXHXD)		inch	33.3X10.8X7
	Dimension of Carton Box (LXWXH)		inch	36X10X14
Dimension of Package (LXWXH)		inch	36.1X10.2X14.6	
Net Weight		lb	24.255	
Gross Weight		lb	30.87	

Outdoor Unit	Outdoor Unit Model		GWC09MB-D3DNA3D/O	GWH09MB-D3DNA3D/O
	Outdoor Unit Product Code		CB171W06600	CB171W04500
	Compressor Manufacturer		MITSUBISHI ELECTRIC (GUANGZHOU) COMPRESSOR CO., LTD	MITSUBISHI ELECTRIC (GUANGZHOU) COMPRESSOR CO.LTD
	Compressor Model		KNB092FTAMC	KNB092FTAMC
	Compressor Oil		FV50S	FV50S
	Compressor Type		Rotary	Rotary
	Compressor LRA.	A	/	/
	Compressor RLA	A	3.2	3.2
	Compressor Power Input	W	860	860
	Compressor Overload Protector		1NT11L-6578	1NT11L-6578
	Throttling Method		Electron expansion valve	Electron expansion valve
	Set Temperature Range	°F	60.8 ~ 86	60.8 ~ 86
	Cooling Operation Ambient Temperature Range	°F	0.4 ~ 109.4	0.4 ~ 109.4
	Heating Operation Ambient Temperature Range	°F	/	-5 ~ 75.2
	Condenser Form		Aluminum Fin-copper Tube	Aluminum Fin-copper Tube
	Condenser Pipe Diameter	inch	Φ0.37	Φ0.37
	Condenser Rows-fin Gap	inch	2-0.05	2-0.05
	Condenser Coil Length (LXDXW)	inch	29.4X1.7X20	29.4X1.7X20
	Fan Motor Speed	rpm	680/900	680/900
	Fan Motor Power Output	W	30	30
	Fan Motor RLA	A	0.13	0.13
	Fan Motor Capacitor	μF	/	/
	Outdoor Unit Air Flow Volume	CFM	941.6	941.6
	Fan Type		Axial-flow	Axial-flow
	Fan Diameter	inch	15.748	15.748
	Defrosting Method		/	Automatic Defrosting
	Climate Type		T1	T1
	Isolation		I	I
	Moisture Protection		IP24	IP24
	Permissible Excessive Operating Pressure for the Discharge Side	PSIG	550	550
	Permissible Excessive Operating Pressure for the Suction Side	PSIG	450	450
	Sound Pressure Level (H/M/L)	dB (A)	50/-/-	50/-/-
	Sound Power Level (H/M/L)	dB (A)	60/-/-	60/-/-
Dimension (WXHXD)	inch	33.4X21.2X12.6	33.4X21.2X12.6	
Dimension of Carton Box (LXWXH)	inch	34.5X14.2X22.8	34.5X14.2X22.8	
Dimension of Package (LXWXH)	inch	34.7X14.3X23.4	34.7X14.3X23.4	
Net Weight	lb	79.38	79.38	
Gross Weight	lb	90.405	90.405	
Refrigerant		R410A	R410A	
Refrigerant Charge	oz	45.864	45.864	
Connection Pipe	Connection Pipe Length	ft	25	25
	Connection Pipe Gas Additional Charge	oz/ft.	0.5	0.7
	Outer Diameter Liquid Pipe	inch	1/4	1/4
	Outer Diameter Gas Pipe	inch	3/8	3/8
	Max Distance Height	ft	33	33
	Max Distance Length	ft	50	50

The above data is subject to change without notice. Please refer to the nameplate of the unit.

Specifications

Model			GWC12MB-D3DNA3D	GWH12MB-D3DNA3D
Product Code			CB171006700	CB171004600
Power Supply	Rated Voltage	V ~	208/230	208/230
	Rated Frequency	Hz	60	60
	Phases		1	1
Power Supply Mode			Outdoor	Outdoor
Cooling Capacity(Min ~ Max)		Btu/h	12000(3100~13000)	12000(3100~13000)
Heating Capacity(Min ~ Max)		Btu/h	/	13000(2400~14000)
Cooling Power Input(Min ~ Max)		W	1000(365~1080)	1000(365~1080)
Heating Power Input(Min ~ Max)		W	/	1200(340~1360)
Cooling Current Input		A	4.5	4.5
Heating Current Input		A	/	5.2
Rated Input		W	1500	1500
Rated Current		A	7.2	7.2
Air Flow Volume (S/H/M/L)		CFM	335/277/253/218	335/277/253/218
Dehumidifying Volume		Pint/h	2.959	2.959
EER		(Btu/h)/W	12	12
COP		(Btu/h)/W	/	10.8
SEER			20	20
HSPF			/	9.2
Application Area		m ²	16-24	16-24
Indoor Unit	Indoor Unit Model		GWC12MB-D3DNA3D/I	GWH12MB-D3DNA3D/I
	Indoor Unit Product Code		CB171N06700	CB171N04600
	Fan Type		Cross-flow	Cross-flow
	Fan Diameter Length(DXL)		inch	Φ3.6X25.4
	Cooling Speed(S/H/M/L)		r/min	1330/1100/950/750
	Heating Speed(S/H/M/L)		r/min	/
	Fan Motor Power Output		W	20
	Fan Motor RLA		A	0.2
	Fan Motor Capacitor		μF	1
	Evaporator Form		W	Aluminum Fin-copper Tube
	Evaporator Pipe Diameter		inch	Φ0.27
	Evaporator Row-fin Gap		inch	2-0.05
	Evaporator Coil Length (LXDXW)		inch	22.8X1X10.4
	Swing Motor Model			MP24AA
	Swing Motor Power Output		W	2
	Fuse Current		A	3.15
	Sound Pressure Level (S/H/M/L)		dB (A)	44/39/36/33
	Sound Power Level (S/H/M/L)		dB (A)	54/49/46/43
	Dimension (WXHXD)		inch	33.3X10.8X7
	Dimension of Carton Box (LXWXH)		inch	36X10X14
	Dimension of Package (LXWXH)		inch	36.1X10.2X14.6
Net Weight		lb	22	
Gross Weight		lb	28.7	

Outdoor Unit	Outdoor Unit Model		GWC12MB-D3DNA3D/O	GWH12MB-D3DNA3D/O
	Outdoor Unit Product Code		CB171W06700	CB171W04600
	Compressor Manufacturer		MITSUBISHI ELECTRIC (GUANGZHOU) COMPRESSOR CO.LTD	MITSUBISHI ELECTRIC (GUANGZHOU) COMPRESSOR CO.LTD
	Compressor Model		KNB092FTAMC	KNB092FTAMC
	Compressor Oil		FV50S	FV50S
	Compressor Type		Rotary	Rotary
	Compressor LRA.	A	/	/
	Compressor RLA	A	3.2	3.2
	Compressor Power Input	W	860	860
	Compressor Overload Protector		1NT11L-6578	1NT11L-6578
	Throttling Method		Electron expansion valve	Electron expansion valve
	Set Temperature Range	°F	60.8 ~ 86	60.8 ~ 86
	Cooling Operation Ambient Temperature Range	°F	0.4 ~ 109.4	0.4 ~ 109.4
	Heating Operation Ambient Temperature Range	°F	/	-5 ~ 75.2
	Condenser Form		Aluminum Fin-copper Tube	Aluminum Fin-copper Tube
	Condenser Pipe Diameter	inch	Φ0.37	Φ0.37
	Condenser Rows-fin Gap	inch	2-0.05	2-0.05
	Condenser Coil Length (LXD _X W)	inch	29.4X1.7X22	29.4X1.7X22
	Fan Motor Speed	rpm	680/900	680/900
	Fan Motor Power Output	W	30	30
	Fan Motor RLA	A	0.13	0.13
	Fan Motor Capacitor	μF	/	/
	Outdoor Unit Air Flow Volume	CFM	941.6	941.6
	Fan Type		Axial-flow	Axial-flow
	Fan Diameter	inch	15.748	15.748
	Defrosting Method		/	Automatic Defrosting
	Climate Type		T1	T1
	Isolation		I	I
	Moisture Protection		IP24	IP24
	Permissible Excessive Operating Pressure for the Discharge Side	PSIG	550	550
	Permissible Excessive Operating Pressure for the Suction Side	PSIG	450	450
	Sound Pressure Level (H/M/L)	dB (A)	52/-/-	52/-/-
	Sound Power Level (H/M/L)	dB (A)	62/-/-	62/-/-
Dimension (WXHXD)	inch	33.4X23.2X12.6	33.4X23.2X12.6	
Dimension of Carton Box (LXWXH)	inch	34.5X14.2X24.8	34.5X14.2X24.8	
Dimension of Package (LXWXH)	inch	34.7X14.3X25.4	34.7X14.3X25.4	
Net Weight	lb	88.2	88.2	
Gross Weight	lb	97.02	97.02	
Refrigerant		R410A	R410A	
Refrigerant Charge	oz	45.864	45.864	
Connection Pipe	Connection Pipe Length	ft	25	25
	Connection Pipe Gas Additional Charge	oz/ft.	0.53	0.7
	Outer Diameter Liquid Pipe	inch	1/4	1/4
	Outer Diameter Gas Pipe	inch	3/8	3/8
	Max Distance Height	ft	33	33
	Max Distance Length	ft	66	66

The above data is subject to change without notice. Please refer to the nameplate of the unit.

Specifications

Model			GWH09MB-D3DNA3D (electric heating belt)	GWH12MB-D3DNA3D (electric heating belt)
Product Code			CB171004501	CB171004601
Power Supply	Rated Voltage	V ~	208/230	208/230
	Rated Frequency	Hz	60	60
	Phases		1	1
Power Supply Mode			Outdoor	Outdoor
Cooling Capacity(Min ~ Max)		Btu/h	9000(3500~9600)	12000(3100~13000)
Heating Capacity(Min ~ Max)		Btu/h	9800(2200~11000)	13000(2400~14000)
Cooling Power Input(Min ~ Max)		W	620(370~1075)	1000(365~1080)
Heating Power Input(Min ~ Max)		W	750(200~900)	1200(340~1360)
Cooling Current Input		A	2.8	4.5
Heating Current Input		A	3.04	5.2
Rated Input		W	1430	1500
Rated Current		A	7	7.2
Air Flow Volume (S/H/M/L)		CFM	306/277/253/218	335/277/253/218
Dehumidifying Volume		Pint/h	2.54	2.959
EER		(Btu/h)/W	14.2	12
COP		(Btu/h)/W	14	10.8
SEER			22	20
HSPF			9.2	9.2
Application Area		m ²	12-18	16-24
Indoor Unit	Indoor Unit Model		GWH09MB-D3DNA3D/I	GWH12MB-D3DNA3D/I
	Indoor Unit Product Code		CB171N04500	CB171N04600
	Fan Type		Cross-flow	Cross-flow
	Fan Diameter Length(DXL)		inch	Φ3.6X25.4
	Cooling Speed(S/H/M/L)		r/min	1260/1100/950/750
	Heating Speed(S/H/M/L)		r/min	1320/1200/1100/950
	Fan Motor Power Output		W	20
	Fan Motor RLA		A	0.2
	Fan Motor Capacitor		μF	1
	Evaporator Form		W	Aluminum Fin-copper Tube
	Evaporator Pipe Diameter		inch	Φ0.27
	Evaporator Row-fin Gap		inch	2-0.05
	Evaporator Coil Length (LXD _X W)		inch	22.8X1X10.4
	Swing Motor Model			MP24AA
	Swing Motor Power Output		W	2
	Fuse Current		A	3.15
	Sound Pressure Level (S/H/M/L)		dB (A)	42/38/35/32
	Sound Power Level (S/H/M/L)		dB (A)	52/48/45/42
	Dimension (WXHXD)		inch	33.3X10.8X7
	Dimension of Carton Box (LXWXH)		inch	36X10X14
	Dimension of Package (LXWXH)		inch	36.1X10.2X14.6
Net Weight		lb	22	
Gross Weight		lb	28.7	

Outdoor Unit	Outdoor Unit Model		GWH09MB-D3DNA3D/O (electric heating belt)	GWH12MB-D3DNA3D/O (electric heating belt)
	Outdoor Unit Product Code		CB171W04501	CB171W04601
	Compressor Manufacturer		MITSUBISHI ELECTRIC (GUANGZHOU) COMPRESSOR CO.LTD	MITSUBISHI ELECTRIC (GUANGZHOU) COMPRESSOR CO.LTD
	Compressor Model		KNB092FTAMC	KNB092FTAMC
	Compressor Oil		FV50S	FV50S
	Compressor Type		Rotary	Rotary
	Compressor LRA.	A	/	/
	Compressor RLA	A	3.2	3.2
	Compressor Power Input	W	860	860
	Compressor Overload Protector		1NT11L-6578	1NT11L-6578
	Throttling Method		Electron expansion valve	Electron expansion valve
	Set Temperature Range	°F	60.8 ~ 86	60.8 ~ 86
	Cooling Operation Ambient Temperature Range	°F	0.4 ~ 109.4	0.4 ~ 109.4
	Heating Operation Ambient Temperature Range	°F	-5 ~ 75.2	-5 ~ 75.2
	Condenser Form		Aluminum Fin-copper Tube	Aluminum Fin-copper Tube
	Condenser Pipe Diameter	inch	Φ0.37	Φ0.37
	Condenser Rows-fin Gap	inch	2-0.05	2-0.05
	Condenser Coil Length (LXDXW)	inch	29.4X1.7X20	29.4X1.7X22
	Fan Motor Speed	rpm	680/900	680/900
	Fan Motor Power Output	W	30	30
	Fan Motor RLA	A	0.13	0.13
	Fan Motor Capacitor	μF	/	/
	Outdoor Unit Air Flow Volume	CFM	941.6	941.6
	Fan Type		Axial-flow	Axial-flow
	Fan Diameter	inch	15.748	15.748
	Defrosting Method		Automatic Defrosting	Automatic Defrosting
	Climate Type		T1	T1
	Isolation		I	I
	Moisture Protection		IP24	IP24
	Permissible Excessive Operating Pressure for the Discharge Side	PSIG	550	550
	Permissible Excessive Operating Pressure for the Suction Side	PSIG	450	450
	Sound Pressure Level (H/M/L)	dB (A)	50/-/-	52/-/-
	Sound Power Level (H/M/L)	dB (A)	60/-/-	62/-/-
Dimension (WXHxD)	inch	33.4X21.2X12.6	33.4X23.2X12.6	
Dimension of Carton Box (LXWXH)	inch	34.5X14.2X22.8	34.5X14.2X24.8	
Dimension of Package (LXWXH)	inch	34.7X14.3X23.4	34.7X14.3X25.4	
Net Weight	lb	79.38	88.2	
Gross Weight	lb	90.405	97.02	
Refrigerant		R410A	R410A	
Refrigerant Charge	oz	45.864	45.864	
Connection Pipe	Connection Pipe Length	ft	25	25
	Connection Pipe Gas Additional Charge	oz/ft.	0.7	0.7
	Outer Diameter Liquid Pipe	inch	1/4	1/4
	Outer Diameter Gas Pipe	inch	3/8	3/8
	Max Distance Height	ft	33	33
	Max Distance Length	ft	50	66

Specifications

Model			GWC18MC-D3DNA3D GWC18MC-D3DNA4D GWC18MC-D3DNA5D GWC18MC-D3DNA8D GWC18MC-D3DNC1D GWC18MC-D3DND3D GWC18MC-D3DNE3D	GWH18MC-D3DNA3D GWH18MC-D3DNA4D GWH18MC-D3DNA5D GWH18MC-D3DNA8D GWH18MC-D3DND3D	
Product Code			CB171006800 CB161005100 CB162005300 CB173003600 CB139004300 CB405001600 CB404001100	CB171004700 CB161005200 CB162005400 CB173003700 CB405001700	
Power Supply	Rated Voltage	V ~	208/230	208/230	
	Rated Frequency	Hz	60	60	
	Phases		1	1	
Power Supply Mode			Outdoor	Outdoor	
Cooling Capacity(Min ~ Max)		Btu/h	18000(5970~22350)	18000(5970~22350)	
Heating Capacity(Min ~ Max)		Btu/h	/	19800(4100~22000)	
Cooling Power Input(Min ~ Max)		W	1500(300~2650)	1500(300~2650)	
Heating Power Input(Min ~ Max)		W	/	1650(335~2750)	
Cooling Current Input		A	6.65	6.65	
Heating Current Input		A	/	7.320	
Rated Input		W	2650	2750	
Rated Current		A	11.757	12.201	
Air Flow Volume (S/H/M/L)		CFM	500/459/383/324	500/459/383/324	
Dehumidifying Volume		Pint/h	0.852	0.852	
EER		(Btu/h)/W	12	12	
COP		(Btu/h)/W	/	12	
SEER			18	18	
HSPF			/	10	
Application Area		m ²	27-42	27-42	
Indoor Unit	Indoor Unit Model		GWC18MC-D3DNA3D/I GWC18MC-D3DNA4D/I GWC18MC-D3DNA5D/I GWC18MC-D3DNA8D/I GWC18MC-D3DNC1D/I GWC18MC-D3DND3D/I GWC18MC-D3DNE3D/I	GWH18MC-D3DNA3D/I GWH18MC-D3DNA4D/I GWH18MC-D3DNA5D/I GWH18MC-D3DNA8D/I GWH18MC-D3DND3D/I	
	Indoor Unit Product Code		CB171N06800 CB161N05100 CB162N05300 CB173N03600 CB139N04300 CB405N01600 CB404N01100	CB171N04700 CB161N05200 CB162N05400 CB173N03700 CB405N01700	
	Fan Type			Cross-flow	Cross-flow
	Fan Diameter Length(DXL)		inch	Φ3.86X28	Φ3.86X28
	Cooling Speed(S/H/M/L)		r/min	1500/1200/1050/900	1500/1200/1050/900
	Heating Speed(S/H/M/L)		r/min	/	1500/1250/1150/1050
	Fan Motor Power Output		W	20	20
	Fan Motor RLA		A	0.32	0.32
	Fan Motor Capacitor		μF	1.5	1.5
	Evaporator Form		W	Aluminum Fin-copper Tube	Aluminum Fin-copper Tube
	Evaporator Pipe Diameter		inch	Φ0.27	Φ0.27
	Evaporator Row-fin Gap		inch	2-0.05	2-0.05
	Evaporator Coil Length (LXD _X W)		inch	28X1X12	28X1X12
	Swing Motor Model			MP28VB	MP28VB
	Swing Motor Power Output		W	2.5	2.5
	Fuse Current		A	3.15	3.15
	Sound Pressure Level (S/H/M/L)		dB (A)	49/44/40/35	49/44/40/35
	Sound Power Level (S/H/M/L)		dB (A)	59/54/50/45	59/54/50/45
	Dimension (WXHXD)		inch	37X11.7X7.9	37X11.7X7.9
	Dimension of Carton Box (LXWXH)		inch	39.6X11.1X14.4	39.6X11.1X14.4
	Dimension of Package (LXWXH)		inch	39.7X11.2X15	39.7X11.2X15
Net Weight		lb	28.665	28.665	
Gross Weight		lb	37.485	37.485	

Outdoor Unit	Outdoor Unit Model		GWC18MC-D3DNA3D/O	GWH18MC-D3DNA3D/O
	Outdoor Unit Product Code		CB171W06800	CB171W04700
	Compressor Manufacturer		MITSUBISHI ELECTRIC (GUANGZHOU) COMPRESSOR CO.,LTD	MITSUBISHI ELECTRIC (GUANGZHOU) COMPRESSOR CO.,LTD
	Compressor Model		SNB130FGAMC	SNB130FGAMC
	Compressor Oil		FV50S/PVE	FV50S/PVE
	Compressor Type		Rotary	Rotary
	Compressor LRA.	A	13.8	13.8
	Compressor RLA	A	4.1	4.1
	Compressor Power Input	W	1200	1200
	Compressor Overload Protector		INT11L-6578	INT11L-6578
	Throttling Method		Electron expansion valve	Electron expansion valve
	Set Temperature Range	°F	61 ~ 86	61 ~ 86
	Cooling Operation Ambient Temperature Range	°F	19.4 ~ 109.4	19.4 ~ 109.4
	Heating Operation Ambient Temperature Range	°F	/	19.4 ~ 75.2
	Condenser Form		Aluminum Fin-copper Tube	Aluminum Fin-copper Tube
	Condenser Pipe Diameter	inch	Φ0.27	Φ0.27
	Condenser Rows-fin Gap	inch	2-0.05	2-0.05
	Condenser Coil Length (LXDXW)	inch	33X1.5X26	33X1.5X26
	Fan Motor Speed	rpm	800	800
	Fan Motor Power Output	W	60	60
	Fan Motor RLA	A	0.28	0.28
	Fan Motor Capacitor	μF	/	/
	Outdoor Unit Air Flow Volume	CFM	1883.2	1883.2
	Fan Type		Axial-flow	Axial-flow
	Fan Diameter	inch	20.472	20.472
	Defrosting Method		/	Automatic Defrosting
	Climate Type		T1	T1
	Isolation		I	I
	Moisture Protection		IP24	IP24
	Permissible Excessive Operating Pressure for the Discharge Side	PSIG	550	550
	Permissible Excessive Operating Pressure for the Suction Side	PSIG	450	450
	Sound Pressure Level (H/M/L)	dB (A)	56/-/-	56/-/-
	Sound Power Level (H/M/L)	dB (A)	66/-/-	66/-/-
Dimension (WXHXD)	inch	37.6X27.6X15.6	37.6X27.6X15.6	
Dimension of Carton Box (LXWXH)	inch	40.4X18X29	40.4X18X29	
Dimension of Package (LXWXH)	inch	40.5X18X29.5	40.5X18X29.5	
Net Weight	lb	99.225	99.225	
Gross Weight	lb	110.25	110.25	
Refrigerant		R410A	R410A	
Refrigerant Charge	oz	49.392	49.392	
Connection Pipe	Connection Pipe Length	ft	25	25
	Connection Pipe Gas Additional Charge	oz/ft.	0.2	0.2
	Outer Diameter Liquid Pipe	inch	1/4	1/4
	Outer Diameter Gas Pipe	inch	1/2	1/2
	Max Distance Height	ft	33	33
	Max Distance Length	ft	82	82

The above data is subject to change without notice. Please refer to the nameplate of the unit.

Specifications

Model			GWC24MD-D3DNA3D GWC24MD-D3DNA4D GWC24MD-D3DNA5D GWC24MD-D3DNA8D GWC24MD-D3DND3D GWC24MD-D3DNE3D GWC24MD-D3DNC1D	GWH24MD-D3DNA3D GWH24MD-D3DNA4D GWH24MD-D3DNA5D GWH24MD-D3DNA8D GWH24MD-D3DND3D	
Product Code			CB171006900 CB161004500 CB162005000 CB173003800 CB405001800 CB404001200 CB139004400	CB171007000 CB161004600 CB162005100 CB173003900 CB405001900	
Power Supply	Rated Voltage	V ~	208/230	208/230	
	Rated Frequency	Hz	60	60	
	Phases		1	1	
Power Supply Mode			Outdoor	Outdoor	
Cooling Capacity(Min ~ Max)		Btu/h	21400(9600~25000)	21400(9600~25000)	
Heating Capacity(Min ~ Max)		Btu/h	/	23000(4300~26000)	
Cooling Power Input(Min ~ Max)		W	1780(500~2650)	1780(500~2650)	
Heating Power Input(Min ~ Max)		W	/	2100(400~2750)	
Cooling Current Input		A	7.941	7.941	
Heating Current Input		A	/	9.317	
Rated Input		W	2650	2750	
Rated Current		A	11.757	12.201	
Air Flow Volume (S/H/M/L)		CFM	589/471/412/353	589/471/412/353	
Dehumidifying Volume		Pint/h	1.183	1.183	
EER		(Btu/h)/W	12	12	
COP		(Btu/h)/W	/	10.95	
SEER			18	18	
HSPF			/	10	
Application Area		m ²	27-42	27-42	
Indoor Unit	Indoor Unit Model		GWC24MD-D3DNA3D/I GWC24MD-D3DNA4D/I GWC24MD-D3DNA5D/I GWC24MD-D3DNA8D/I GWC24MD-D3DND3D/I GWC24MD-D3DNE3D/I GWC24MD-D3DNC1D/I	GWH24MD-D3DNA3D/I GWH24MD-D3DNA4D/I GWH24MD-D3DNA5D/I GWH24MD-D3DNA8D/I GWH24MD-D3DND3D/I	
	Indoor Unit Product Code		CB171N06900 CB161N04500 CB162N05000 CB173N03800 CB405N01800 CB404N01200 CB139N04400	CB171N07000 CB161N04600 CB162N05100 CB173N03900 CB405N01900	
	Fan Type			Cross-flow	Cross-flow
	Fan Diameter Length(DXL)		inch	Φ3.86X30	Φ3.86X30
	Cooling Speed(S/H/M/L)		r/min	1500/1200/1050/900	1500/1200/1050/900
	Heating Speed(S/H/M/L)		r/min	/	1450/1150/1020/950
	Fan Motor Power Output		W	60	60
	Fan Motor RLA		A	0.24	0.24
	Fan Motor Capacitor		μF	/	/
	Evaporator Form		W	Aluminum Fin-copper Tube	Aluminum Fin-copper Tube
	Evaporator Pipe Diameter		inch	Φ0.27	Φ0.27
	Evaporator Row-fin Gap		inch	2-0.06	2-0.06
	Evaporator Coil Length (LXD _X W)		inch	30X1X15.5	30X1X15.5
	Swing Motor Model			MP35XX	MP35XX
	Swing Motor Power Output		W	3	3
	Fuse Current		A	3.15	3.15
	Sound Pressure Level (S/H/M/L)		dB (A)	53/45/41/37	53/45/41/37
	Sound Power Level (S/H/M/L)		dB (A)	63/55/51/47	63/55/51/47
	Dimension (WXHXD)		inch	39.7X12.4X8.6	39.7X12.4X8.6
	Dimension of Carton Box (LXWXH)		inch	42.2X15.5X12.3	42.2X15.5X12.3
	Dimension of Package (LXWXH)		inch	42.4X15.7X12.9	42.4X15.7X12.9
	Net Weight		lb	35.28	35.28
	Gross Weight		lb	46.305	46.305

Outdoor Unit	Outdoor Unit Model		GWC24MD-D3DNA3D/O	GWH24MD-D3DNA3D /O
	Outdoor Unit Product Code		CB171W06900	CB171W07000
	Compressor Manufacturer		mitsubishi electric (GUANGZHOU)COMPRESSOR CO. LTD	mitsubishi electric (GUANGZHOU)COMPRESSOR CO. LTD
	Compressor Model		SNB150FGAMC	SNB150FGAMC
	Compressor Oil		PVE/FV50S	PVE/FV50S
	Compressor Type		Rotary	Rotary
	Compressor LRA.	A	18.5	18.5
	Compressor RLA	A	4.9	4.9
	Compressor Power Input	W	1420	1420
	Compressor Overload Protector		1NT11L-6578	1NT11L-6578
	Throttling Method		Electron expansion valve	Electron expansion valve
	Set Temperature Range	°F	61 ~ 86	61 ~ 86
	Cooling Operation Ambient Temperature Range	°F	19.4 ~ 109.4	19.4 ~ 109.4
	Heating Operation Ambient Temperature Range	°F	/	19.4 ~ 75.2
	Condenser Form		Aluminum Fin-copper Tube	Aluminum Fin-copper Tube
	Condenser Pipe Diameter	inch	Φ0.27	Φ0.27
	Condenser Rows-fin Gap	inch	2-0.05	2-0.05
	Condenser Coil Length (LXDXW)	inch	38X1.5X29	38X1.5X29
	Fan Motor Speed	rpm	800	800
	Fan Motor Power Output	W	90	90
	Fan Motor RLA	A	1.1	1.1
	Fan Motor Capacitor	μF	4	4
	Outdoor Unit Air Flow Volume	CFM	2354	2354
	Fan Type		Axial-flow	Axial-flow
	Fan Diameter	inch	21.732	21.732
	Defrosting Method		/	Automatic Defrosting
	Climate Type		T1	T1
	Isolation		I	I
	Moisture Protection		IP24	IP24
	Permissible Excessive Operating Pressure for the Discharge Side	PSIG	550	550
	Permissible Excessive Operating Pressure for the Suction Side	PSIG	450	450
	Sound Pressure Level (H/M/L)	dB (A)	58/-/-	58/-/-
	Sound Power Level (H/M/L)	dB (A)	68/-/-	68/-/-
Dimension (WXHXD)	inch	38.6X31.1X16.8	38.6X31.1X16.8	
Dimension of Carton Box (LXWXH)	inch	42.5X19X33	42.5X19X33	
Dimension of Package (LXWXH)	inch	42.6X19.2X33.7	42.6X19.2X33.7	
Net Weight	lb	119.07	121.275	
Gross Weight	lb	132.3	134.505	
Refrigerant		R410A	R410A	
Refrigerant Charge	oz	56.448	56.448	
Connection Pipe	Connection Pipe Length	ft	25	25
	Connection Pipe Gas Additional Charge	oz/ft.	0.2	0.5
	Outer Diameter Liquid Pipe	inch	1/4	1/4
	Outer Diameter Gas Pipe	inch	5/8	5/8
	Max Distance Height	ft	33	33
	Max Distance Length	ft	82	82

The above data is subject to change without notice. Please refer to the nameplate of the unit.

Specifications

Model			GWH18MC-D3DNA3D (electric heating band)	GWH24MD-D3DNA3D (electric heating band)	
Product Code			CB171004701	CB171007001	
Power Supply	Rated Voltage	V ~	208/230	208/230	
	Rated Frequency	Hz	60	60	
	Phases		1	1	
Power Supply Mode			Outdoor	Outdoor	
Cooling Capacity(Min ~ Max)		Btu/h	18000(5970~22350)	21400(9600~25000)	
Heating Capacity(Min ~ Max)		Btu/h	19800(4100~22000)	23000(4300~26000)	
Cooling Power Input(Min ~ Max)		W	1500(300~2650)	1780(500~2650)	
Heating Power Input(Min ~ Max)		W	1650(335~2750)	2100(400~2750)	
Cooling Current Input		A	6.65	7.941	
Heating Current Input		A	7.32	9.317	
Rated Input		W	2750	2750	
Rated Current		A	12.201	12.201	
Air Flow Volume (S/H/M/L)		CFM	500/459/383/324	589/471/412/353	
Dehumidifying Volume		Pint/h	0.852	1.183	
EER		(Btu/h)/W	12	12	
COP		(Btu/h)/W	12	10.95	
SEER			18	18	
HSPF			10	10	
Application Area		m ²	27-42	27-42	
Indoor Unit	Indoor Unit Model		GWH18MC-D3DNA3D/I	GWH24MD-D3DNA3D/I	
	Indoor Unit Product Code		CB405N01700	CB405N01900	
	Fan Type		Cross-flow	Cross-flow	
	Fan Diameter Length(DXL)		inch	Φ3.86X28	Φ3.86X30
	Cooling Speed(S/H/M/L)		r/min	1500/1200/1050/900	1500/1200/1050/900
	Heating Speed(S/H/M/L)		r/min	1500/1250/1150/1050	1450/1150/1020/950
	Fan Motor Power Output		W	20	60
	Fan Motor RLA		A	0.32	0.24
	Fan Motor Capacitor		μF	1.5	/
	Evaporator Form		W	Aluminum Fin-copper Tube	Aluminum Fin-copper Tube
	Evaporator Pipe Diameter		inch	Φ0.27	Φ0.27
	Evaporator Row-fin Gap		inch	2-0.05	2-0.06
	Evaporator Coil Length (LXDXW)		inch	28X1X12	30X1X15.5
	Swing Motor Model			MP28VB	MP35XX
	Swing Motor Power Output		W	2.5	3
	Fuse Current		A	3.15	3.15
	Sound Pressure Level (S/H/M/L)		dB (A)	49/44/40/35	53/45/41/37
	Sound Power Level (S/H/M/L)		dB (A)	59/54/50/45	63/55/51/47
	Dimension (WXHXD)		inch	37X11.7X7.9	39.7X12.4X8.6
	Dimension of Carton Box (LXWXH)		inch	39.6X11.1X14.4	42.2X15.5X12.3
Dimension of Package (LXWXH)		inch	39.7X11.2X15	42.4X15.7X12.9	
Net Weight		lb	28.665	35.28	
Gross Weight		lb	37.485	46.305	

Outdoor Unit	Outdoor Unit Model		GWH18MC-D3DNA3D/O(electric heating band)	GWH24MD-D3DNA3D/O(electric heating band)
	Outdoor Unit Product Code		CB171W04701	CB171W07001
	Compressor Manufacturer		MITSUBISHI ELECTRIC (GUANGZHOU) COMPRESSOR CO.,LTD	MITSUBISHI ELECTRIC (GUANGZHOU)COMPRESSOR CO. LTD
	Compressor Model		SNB130FGAMC	SNB150FGAMC
	Compressor Oil		FV50S/PVE	PVE/FV50S
	Compressor Type		Rotary	Rotary
	Compressor LRA.	A	13.8	18.5
	Compressor RLA	A	4.1	4.9
	Compressor Power Input	W	1200	1420
	Compressor Overload Protector		INT11L-6578	1NT11L-6578
	Throttling Method		Electron expansion valve	Electron expansion valve
	Set Temperature Range	°F	61 ~ 86	61 ~ 86
	Cooling Operation Ambient Temperature Range	°F	19.4 ~ 109.4	19.4 ~ 109.4
	Heating Operation Ambient Temperature Range	°F	19.4 ~ 75.2	19.4 ~ 75.2
	Condenser Form		Aluminum Fin-copper Tube	Aluminum Fin-copper Tube
	Condenser Pipe Diameter	inch	Φ0.27	Φ0.27
	Condenser Rows-fin Gap	inch	2-0.05	2-0.05
	Condenser Coil Length (LXDXW)	inch	33X1.5X26	38X1.5X29
	Fan Motor Speed	rpm	800	800
	Fan Motor Power Output	W	60	90
	Fan Motor RLA	A	0.28	1.1
	Fan Motor Capacitor	μF	/	4
	Outdoor Unit Air Flow Volume	CFM	1883.2	2354
	Fan Type		Axial-flow	Axial-flow
	Fan Diameter	inch	20.472	21.732
	Defrosting Method		Automatic Defrosting	Automatic Defrosting
	Climate Type		T1	T1
	Isolation		I	I
	Moisture Protection		IP24	IP24
	Permissible Excessive Operating Pressure for the Discharge Side	PSIG	550	550
	Permissible Excessive Operating Pressure for the Suction Side	PSIG	450	450
	Sound Pressure Level (H/M/L)	dB (A)	56/-/-	58/-/-
Sound Power Level (H/M/L)	dB (A)	66/-/-	68/-/-	
Dimension (WXHXD)	inch	37.6X27.6X15.6	38.6X31.1X16.8	
Dimension of Carton Box (LXWXH)	inch	40.4X18X29	42.5X19X33	
Dimension of Package (LXWXH)	inch	40.5X18X29.5	42.6X19.2X33.7	
Net Weight	lb	99.225	121.275	
Gross Weight	lb	110.25	134.505	
Refrigerant		R410A	R410A	
Refrigerant Charge	oz	49.392	56.448	
Connection Pipe	Connection Pipe Length	ft	25	25
	Connection Pipe Gas Additional Charge	oz/ft.	0.2	0.5
	Outer Diameter Liquid Pipe	inch	Φ1/4	Φ1/4
	Outer Diameter Gas Pipe	inch	Φ1/2	Φ5/8
	Max Distance Height	ft	33	33
	Max Distance Length	ft	82	82

The above data is subject to change without notice. Please refer to the nameplate of the unit.

2.2 Operation Characteristic Curve

(1)09&12K Unit

Cooling

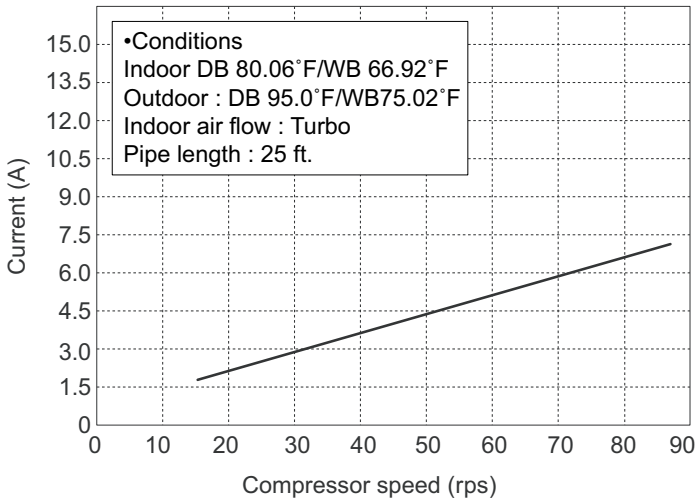

Heating

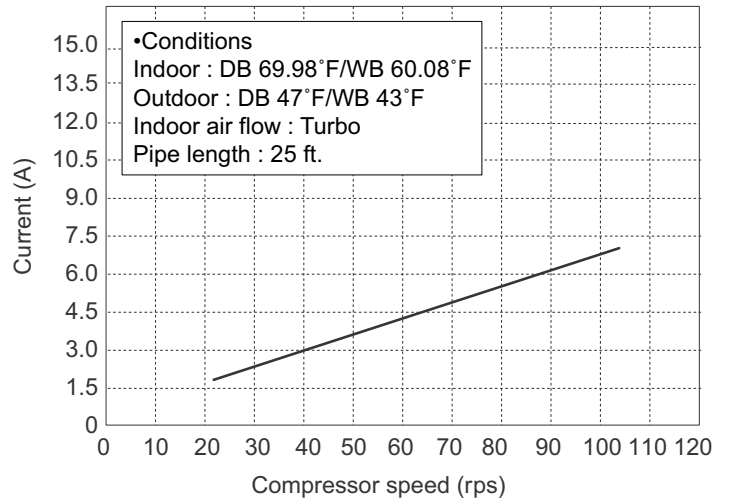

(2)18&24K Unit

Cooling

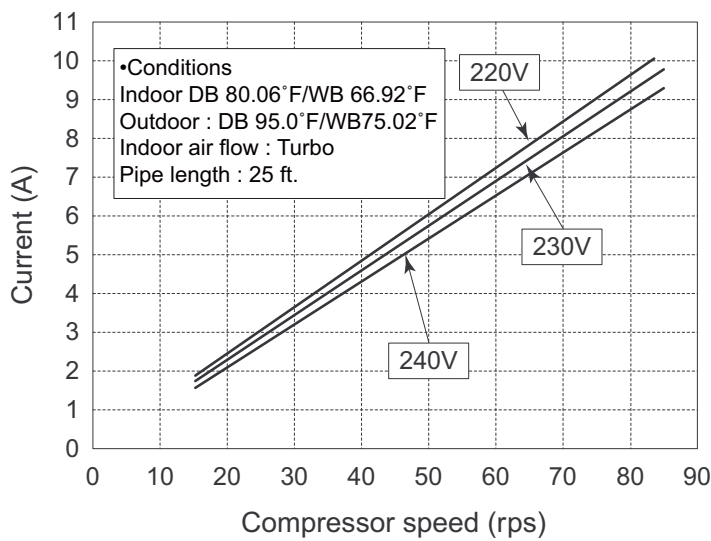

Heating

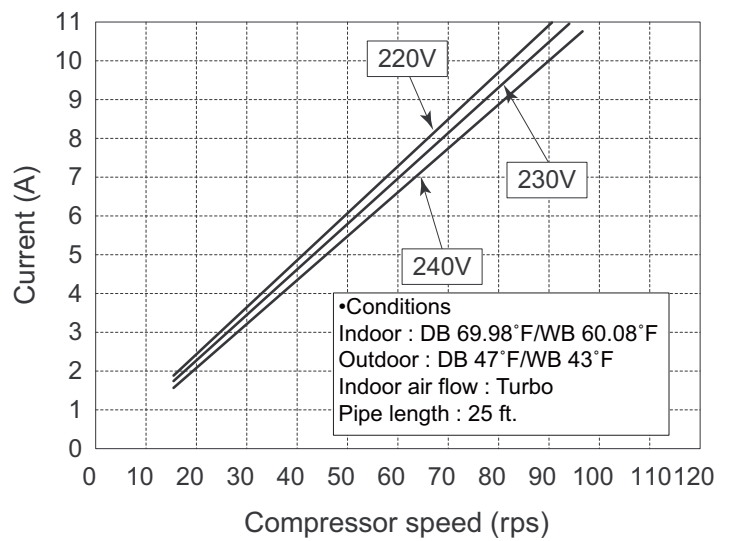

2.3 Capacity Variation Ratio According to Temperature

(1)09&12K Unit

Cooling

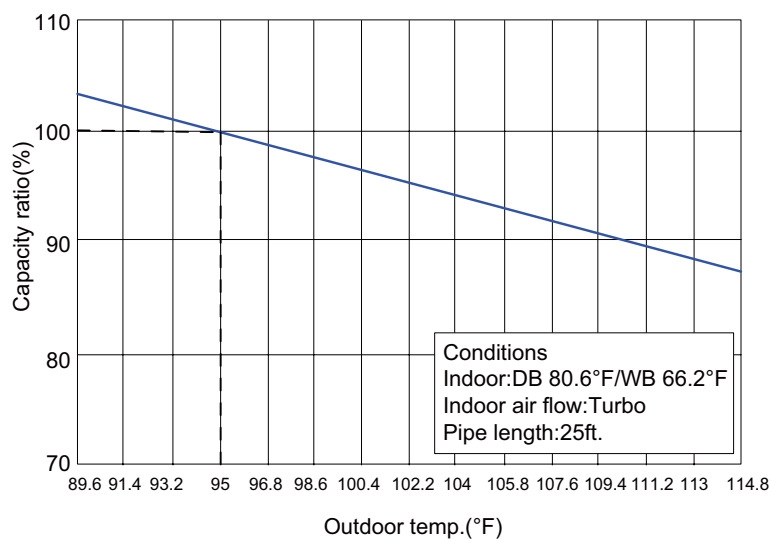

Heating

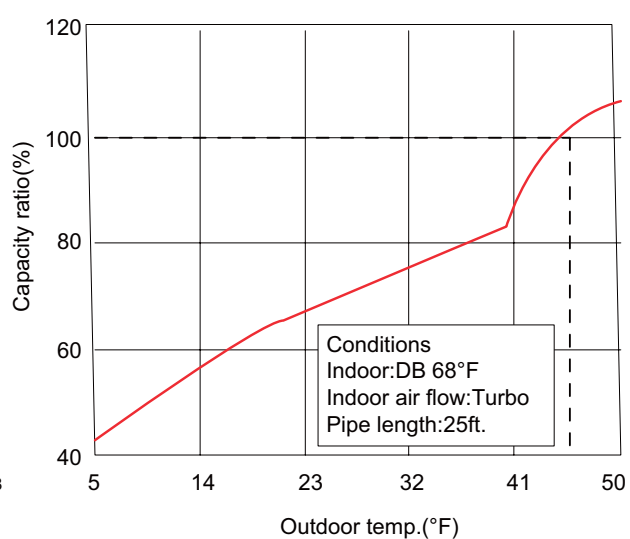

(2)18&24K Unit

Cooling

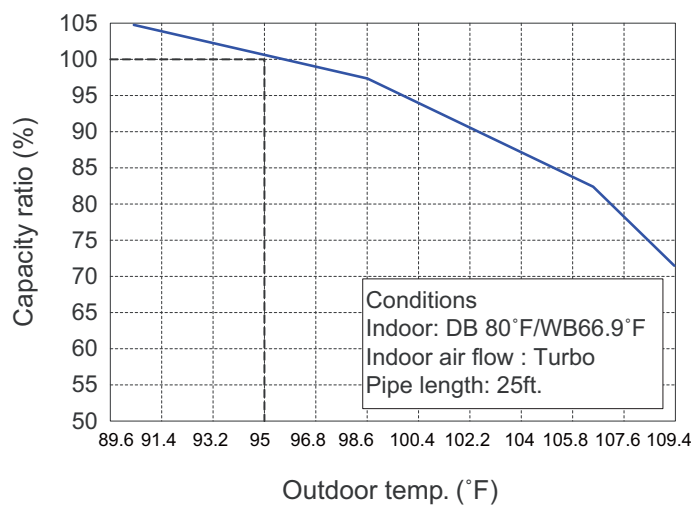

Heating

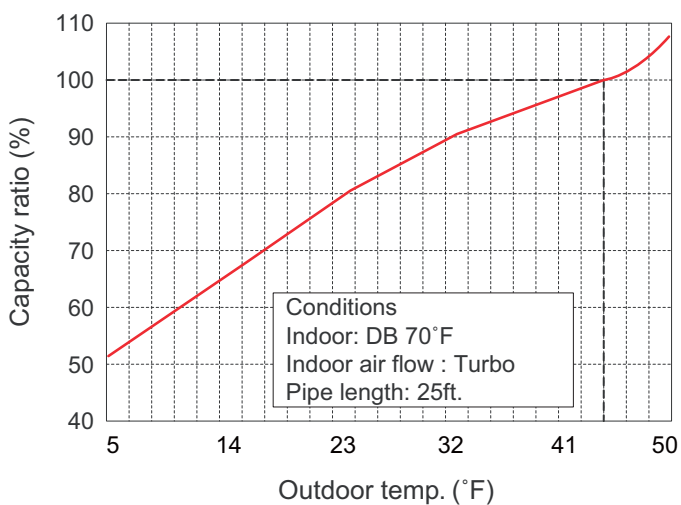

2.4 Noise Criteria Curve Tables for Both Models

(1)09&12K Unit

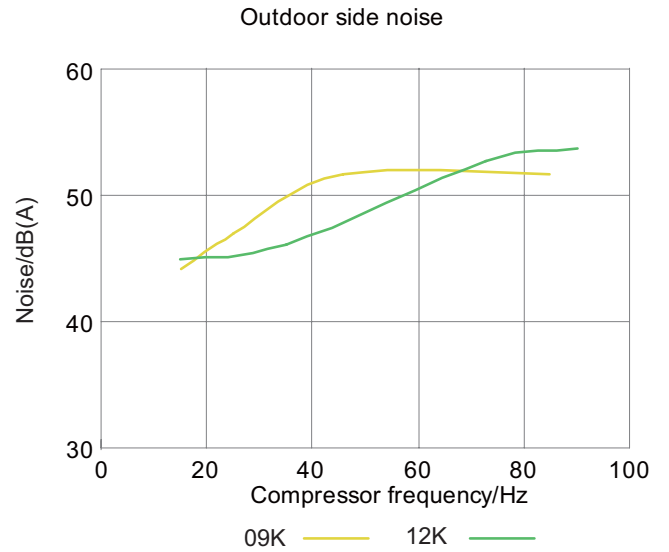
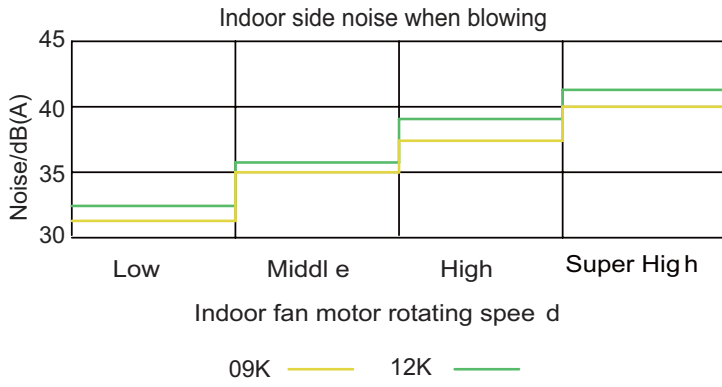

(2)18&24K Unit

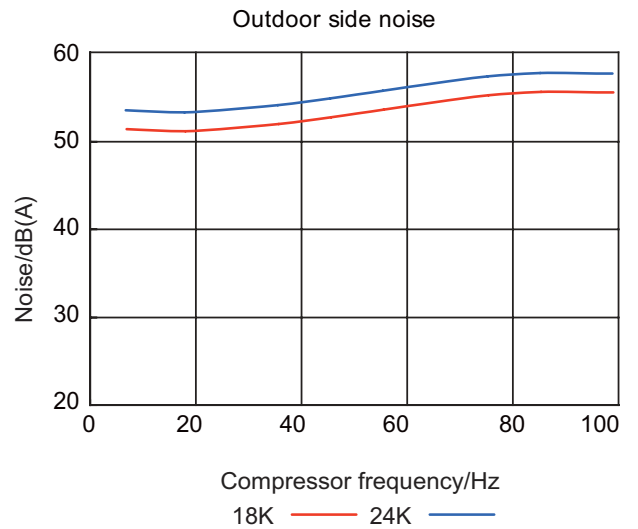
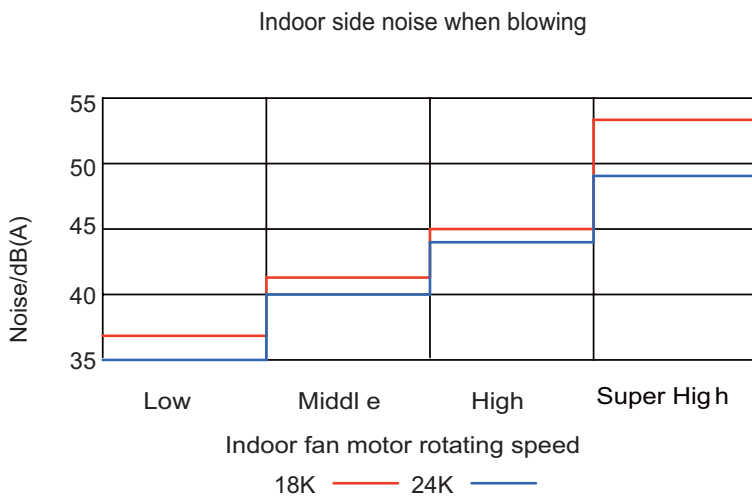

2.5 Operation Data

Cooling

Temperature condition (°F)		Model name	Standard pressure	Heat exchanger pipe temp		Indoor fan mode	Outdoor fan mode	Compressor revolution (rps)
Indoor	Outdoor		P (MPa)	T1 (°F)	T2 (°F)			
80.06/66.92	95/75.02	09K	1.05	59	98.6	Turbo	High	46
		12K	0.93	57.2	98.6			70
		18K	0.9 to 1.1	53.6 to 57.2	109.4 to 105.8			77
		24K	0.8 to 1.0	50 to 53.6	181.4 to 113			72

Heating

Temperature condition (°F)		Model name	Standard pressure	Heat exchanger pipe temp		Indoor fan mode	Outdoor fan mode	Compressor revolution (rps)
Indoor	Outdoor		P (MPa)	T1 (°F)	T2 (°F)			
69.98/60.08	46.994/42.998	09K	2.62	107.6	41	Turbo	High	56
		12K	2.77	115	41			72
		18K	2.2 to 2.4	100.4 to 98.6	35.6 to 39.2			80
		24K	2.5 to 2.7	111.2 to 107.6	32 to 37.4			80

P: The air pipe pressure (gas valve side pressure) connect to indoor and outdoor unit

T1: Inlet and outlet pipe temperature of evaporator

T2: Inlet and outlet pipe temperature of condenser

NOTES :

(1) Measure surface temperature of heat exchanger pipe around center of heat exchanger path U bent.
(Thermistor thermometer)

(2) Connecting piping condition : 25ft.

3. Construction Views

3.1 Indoor Unit

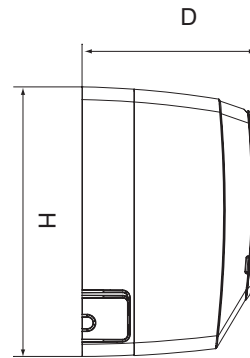
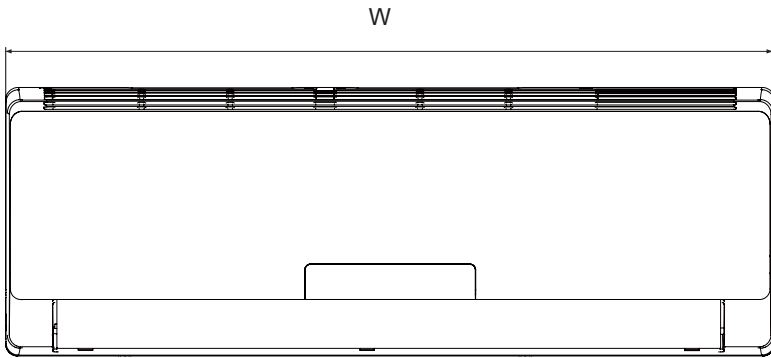

09&12K Unit

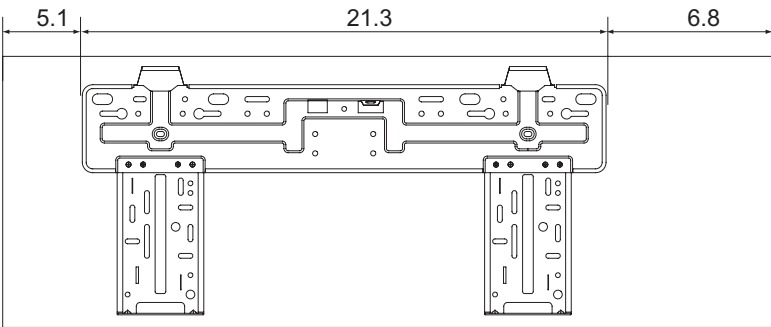

18K Unit

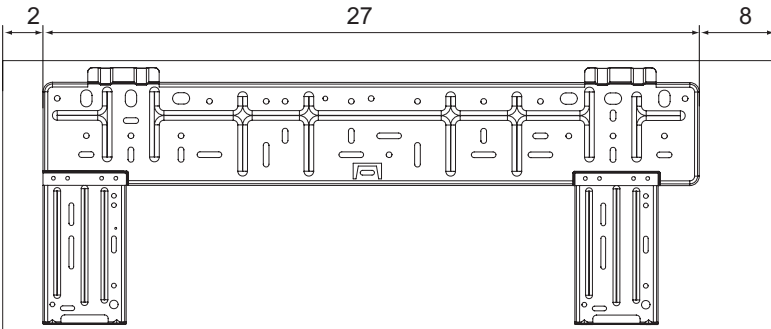

24K Unit

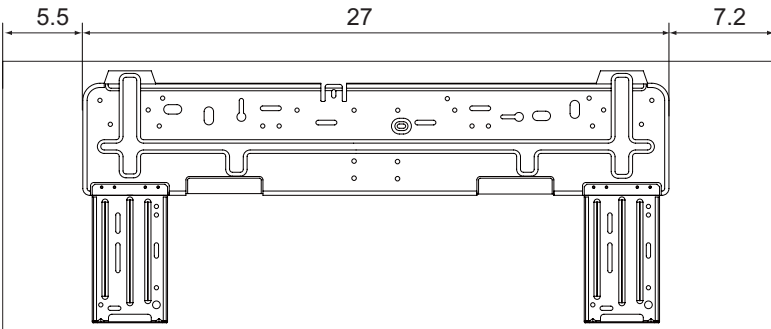

Unit:inch

Model	W	H	D
09&12K	33.3	10.8	7
18K	37	11.7	7.9
24K	39.7	12.4	8.6

3.2 Outdoor Unit

(1)09K Unit

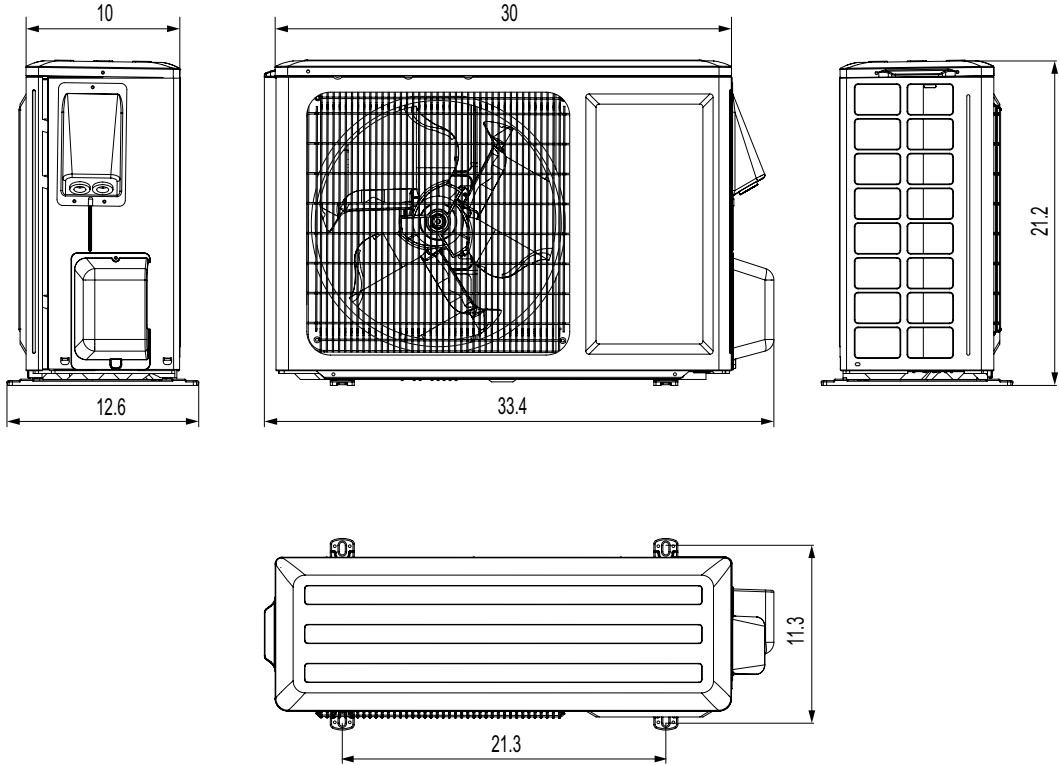

(2)12K Unit

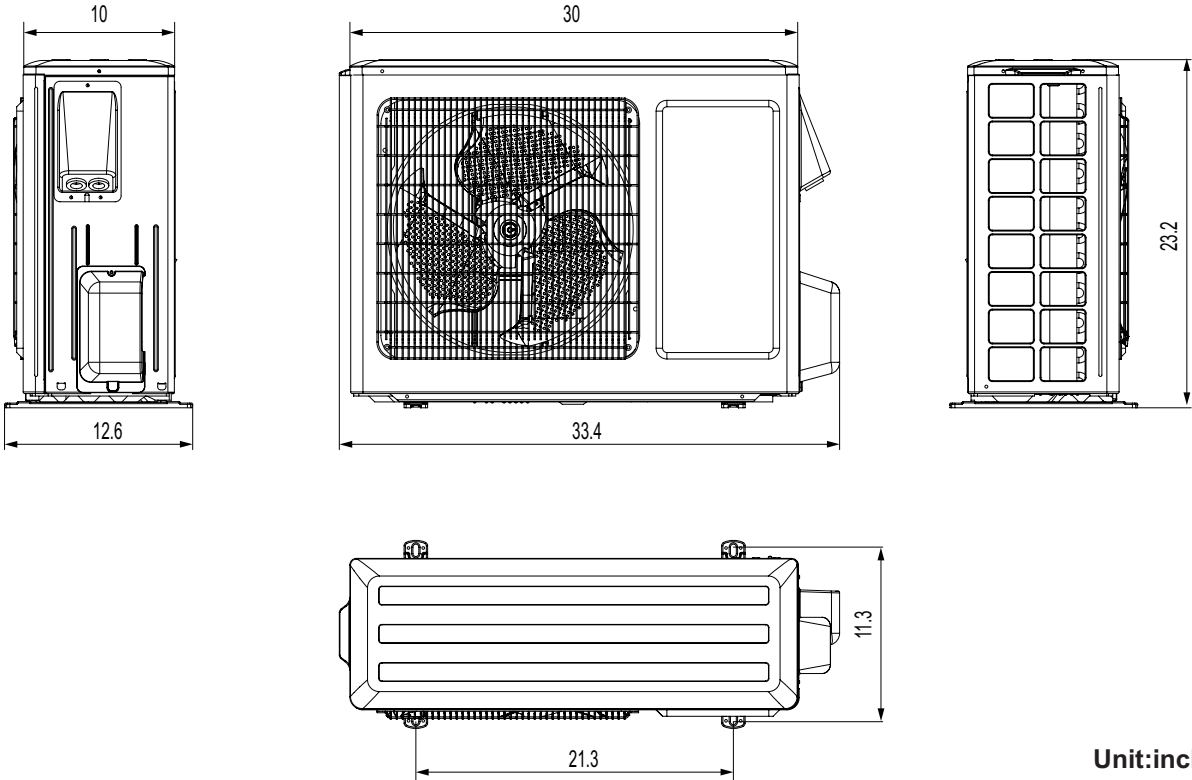

Unit:inch

Construction Views

(3)18K Unit

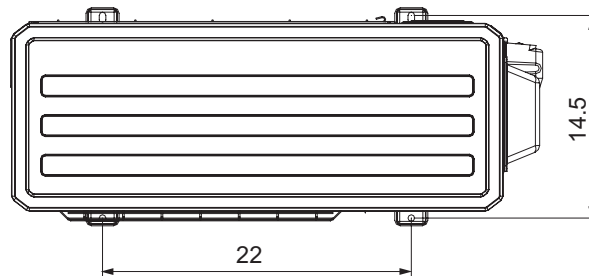
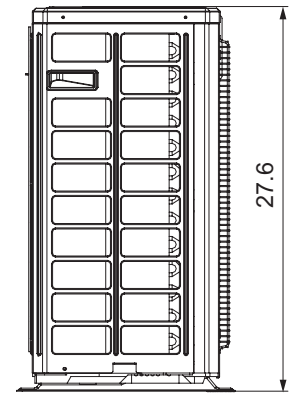
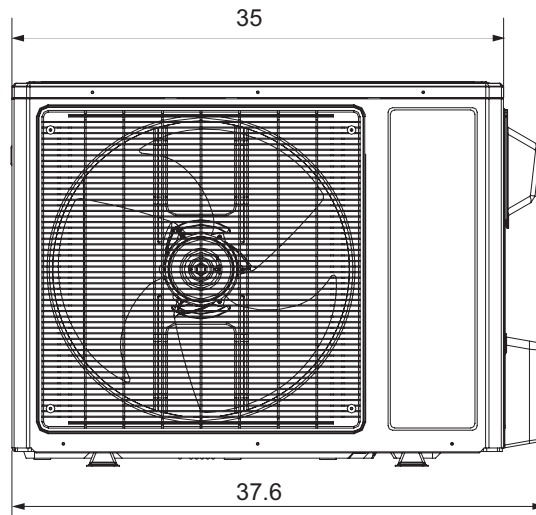
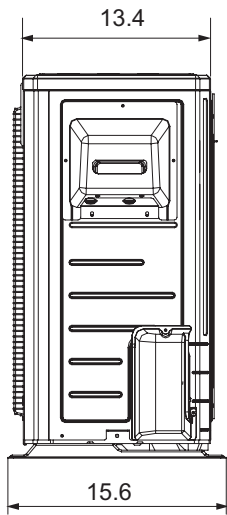

(4)24K Unit

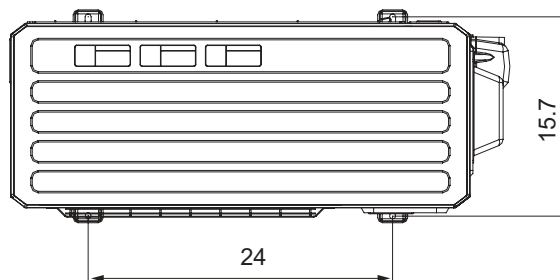
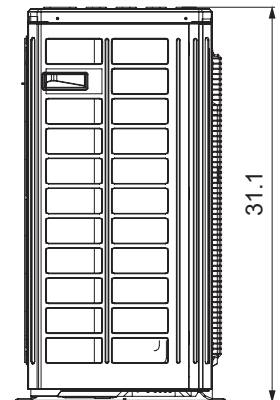
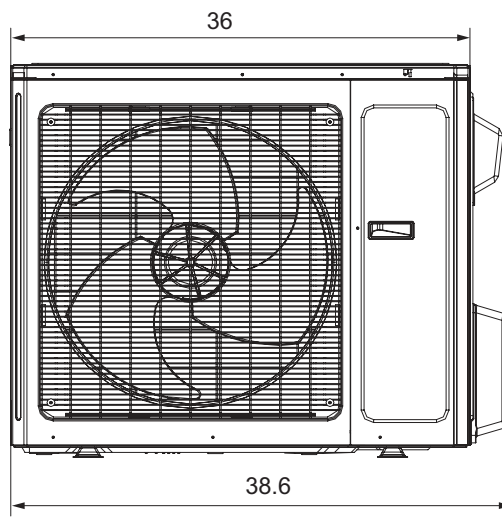
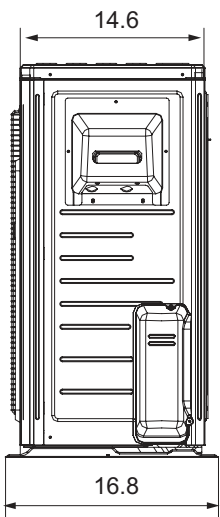

Unit:inch

4. Refrigerant System Diagram

(1) Cooling Only Models

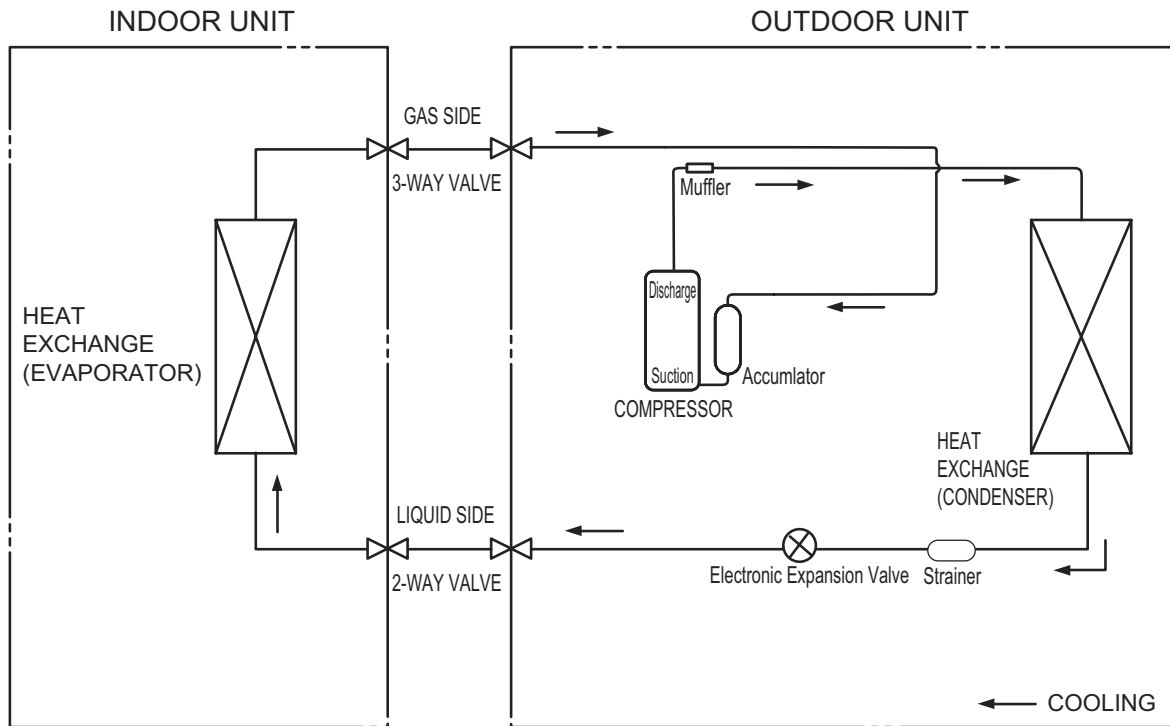

(2) Cooling & Heating Models

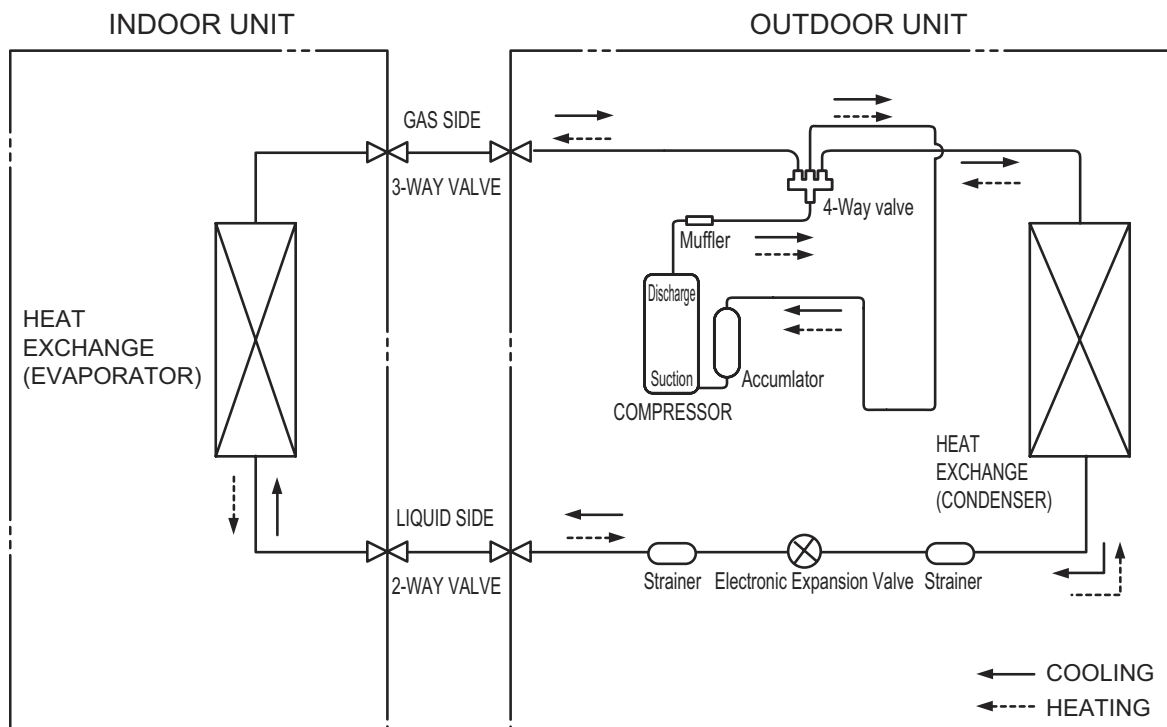

Refrigerant pipe diameter

Liquid : 1/4" Gas : 3/8"(For 09&12K Unit)

Liquid : 1/4" Gas : 1/2"(For 18K Unit)

Liquid : 1/4" Gas : 5/8"(For 24K Unit)

5. Schematic Diagram

5.1 Electrical Data

Meaning of marks

Symbol	Color symbol	Symbol	Parts name
OG	ORANGE		PROTECTIVE EARTH
WH	WHITE	COMP	COMPRESSOR
YE	YELLOW	SAT	OVERLOAD
RD	RED	4V	4-WAY VALVE
YEGN	YELLOW GREEN	XT	TERMINAL BLOCK
BN	BROWN		
BU	BLUE		
BK	BLACK		

5.2 Electrical Wiring

●Indoor Unit

(1)09、12K Unit

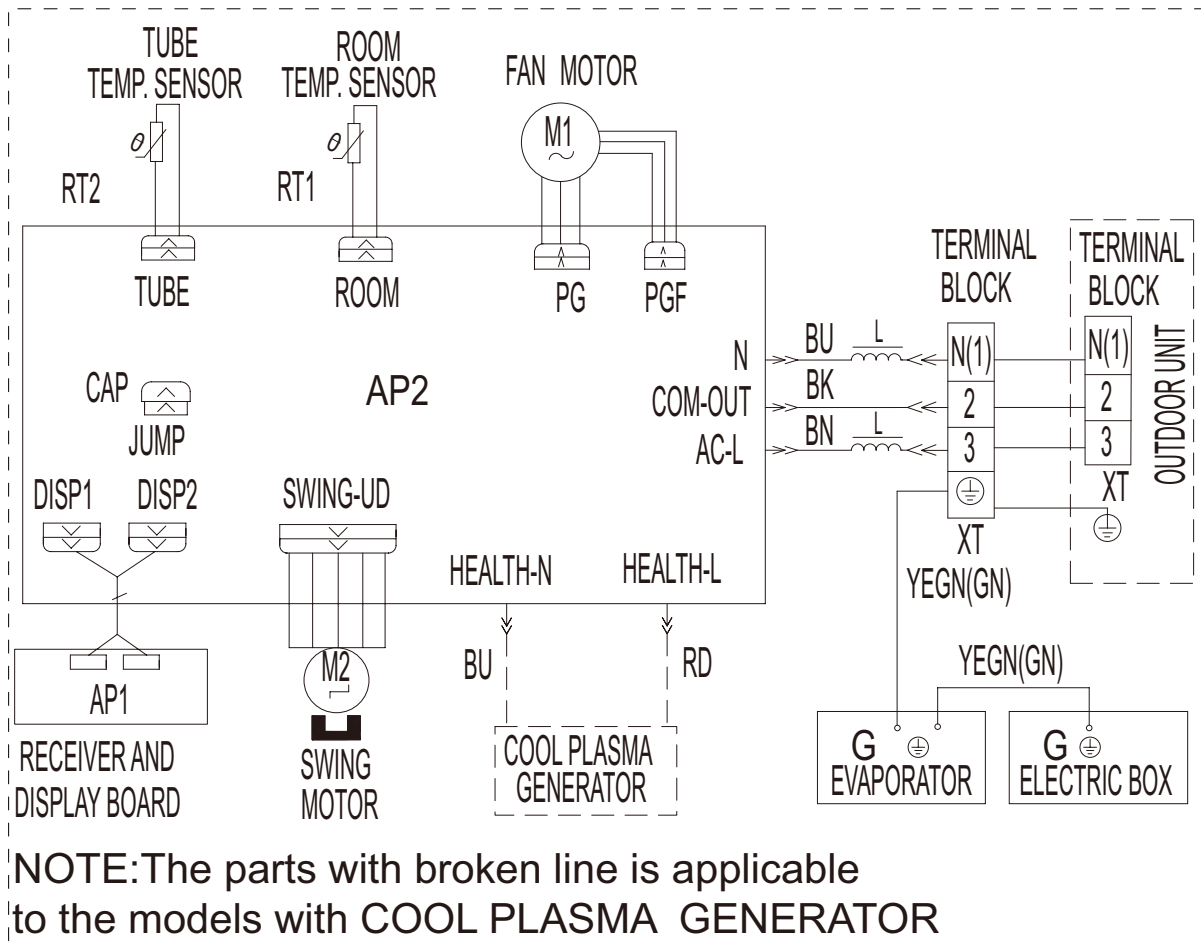

(2)18K Unit

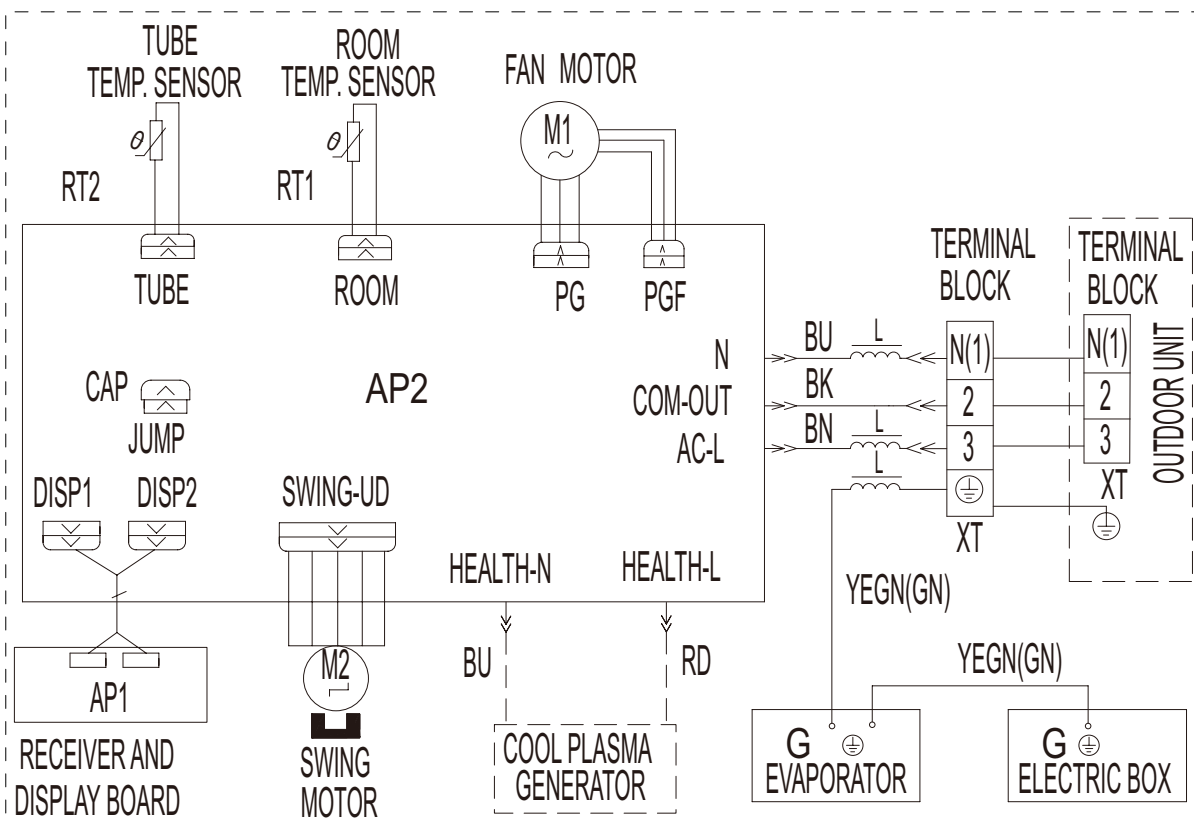

NOTE: The parts with broken line is applicable to the models with COOL PLASMA GENERATOR

(3)24K Unit

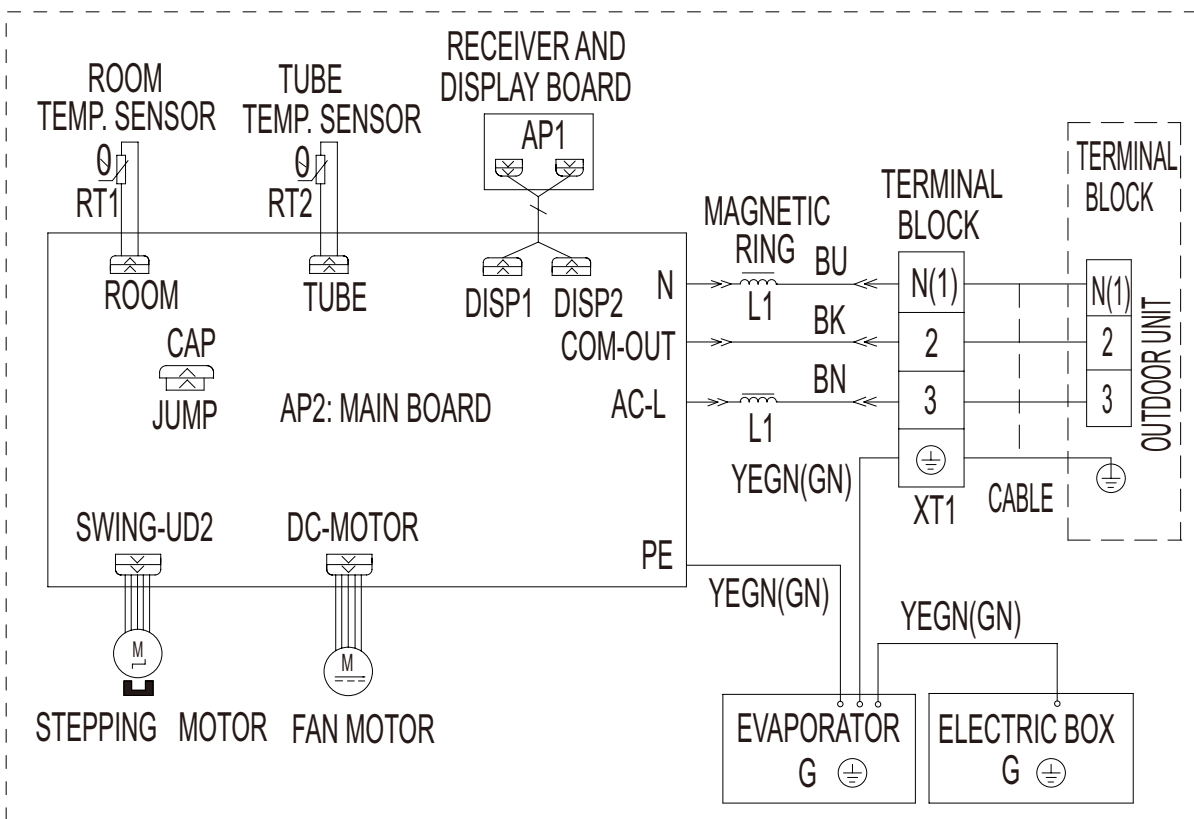

Schematic Diagram

●Outdoor Unit

(1)09、12K Unit

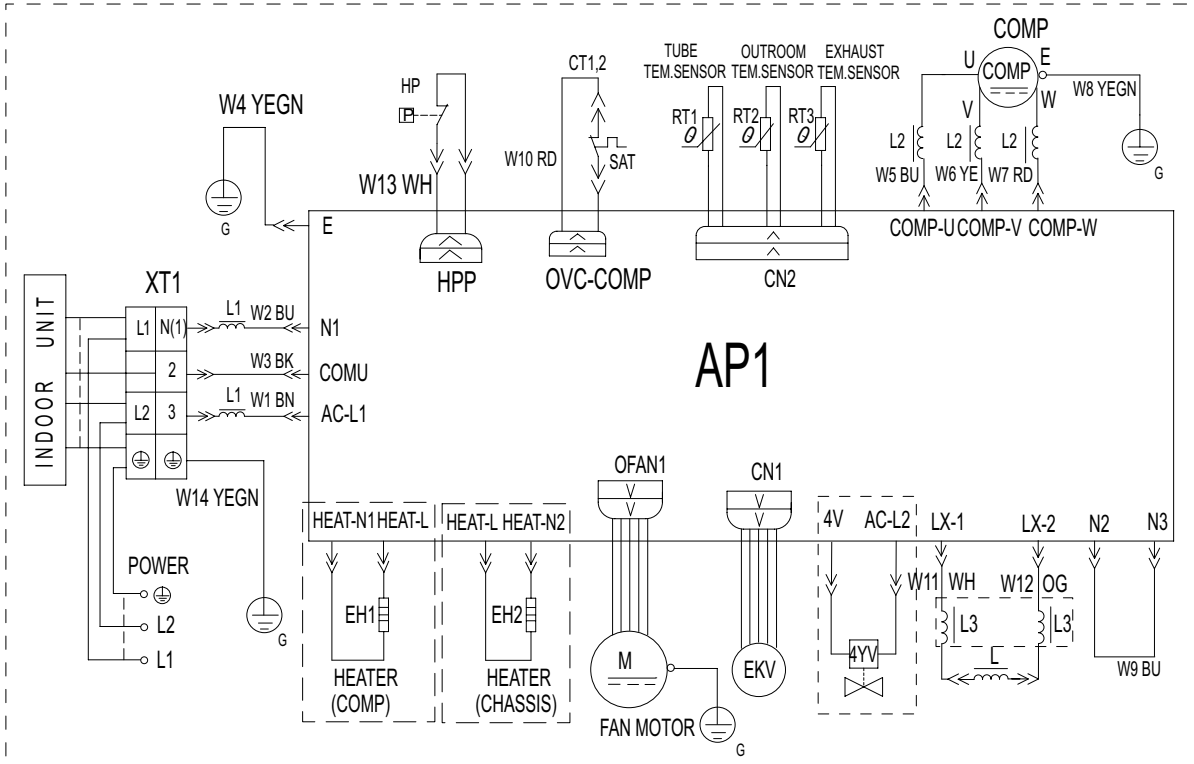

(2)GWC18MC-D3DNA3D/O

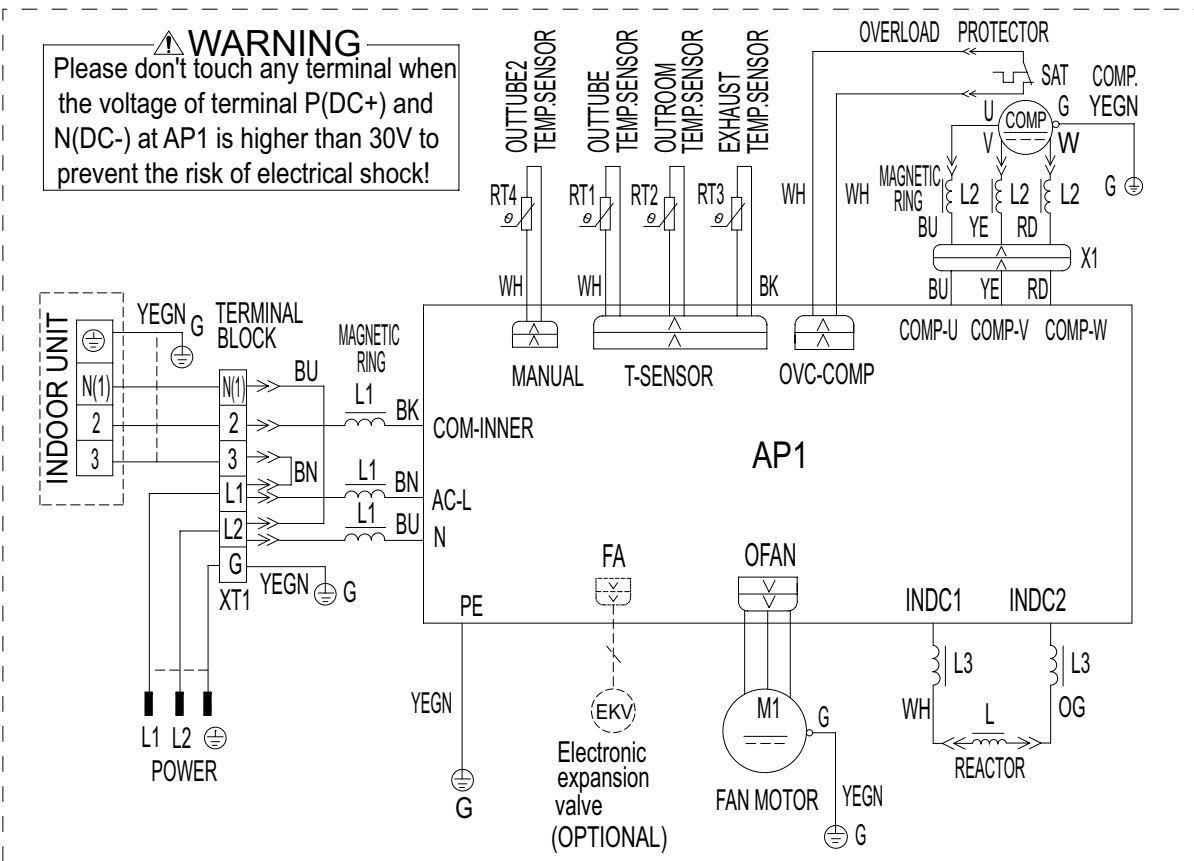

(3)GWH18MC-D3DNA3D/O

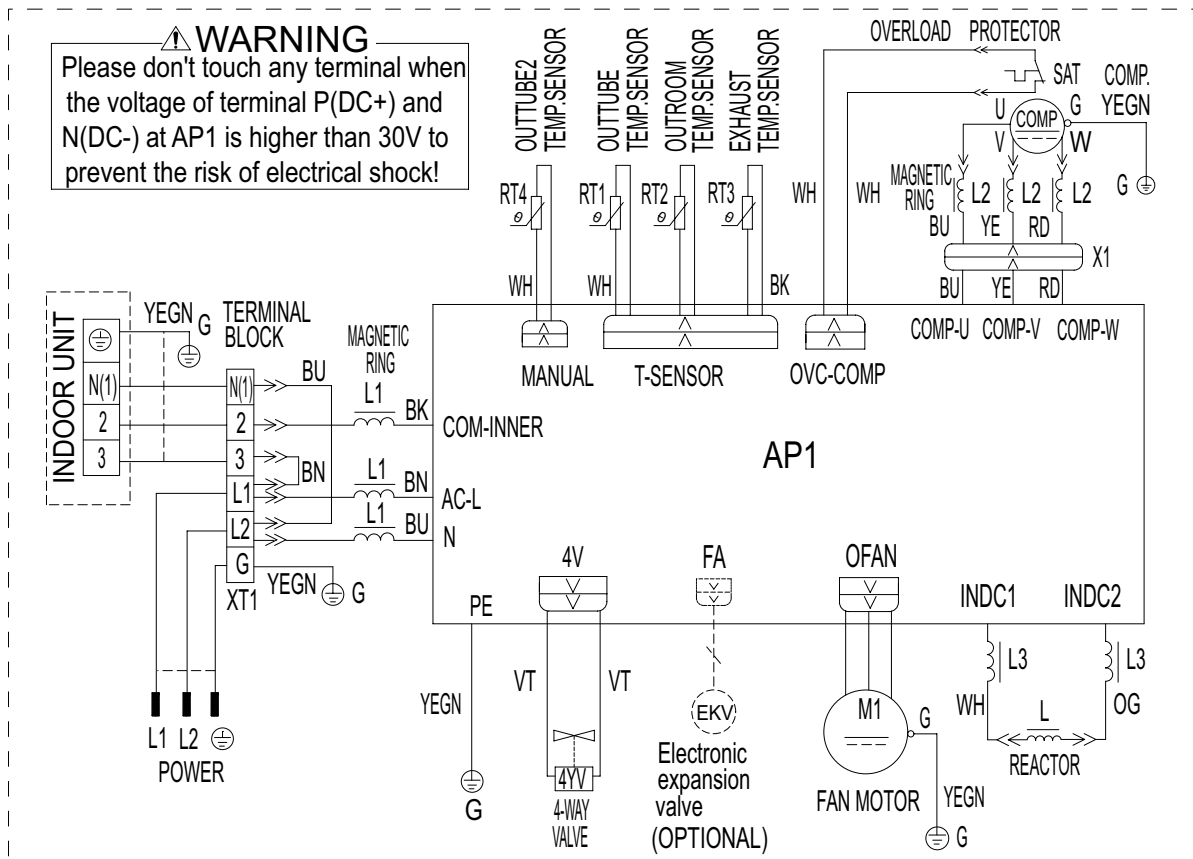

(4)GWC24MD-D3DNA3D/O

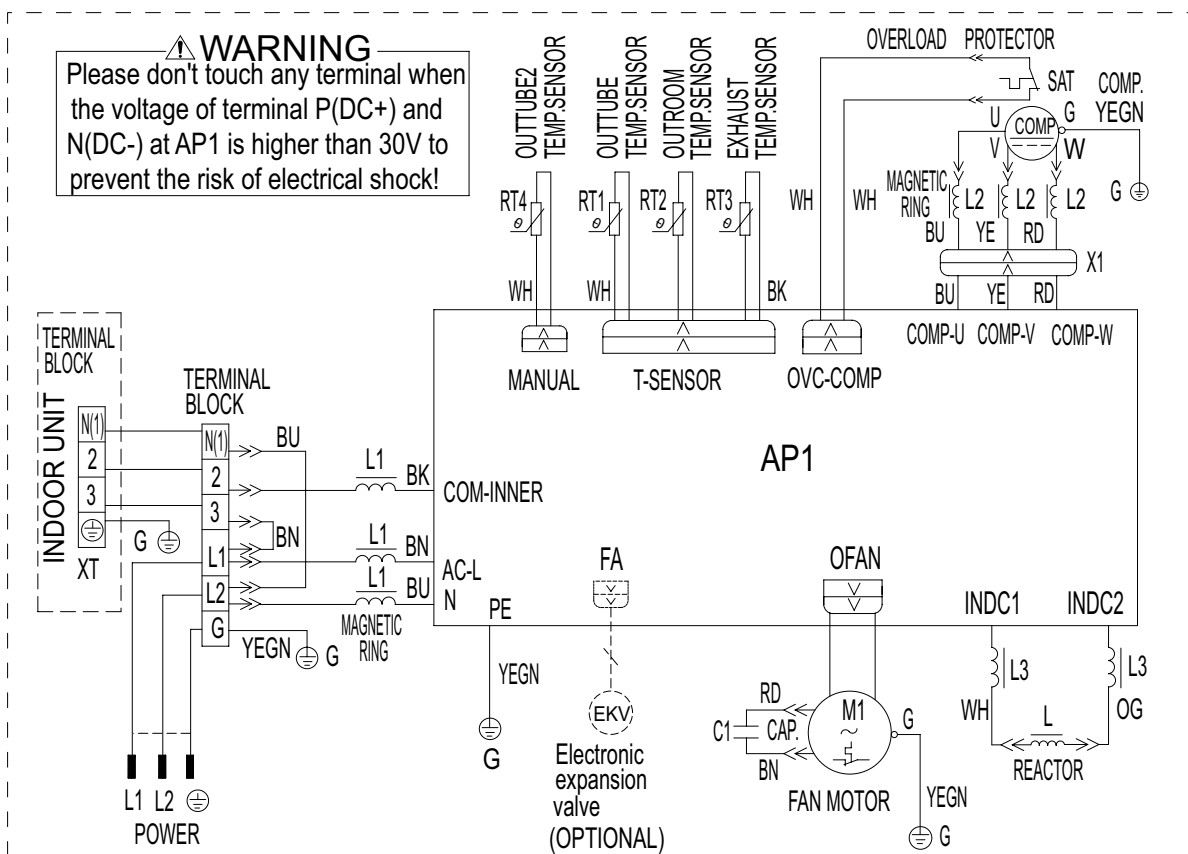

Schematic Diagram

(5)GWH24MD-D3DNA3D/O

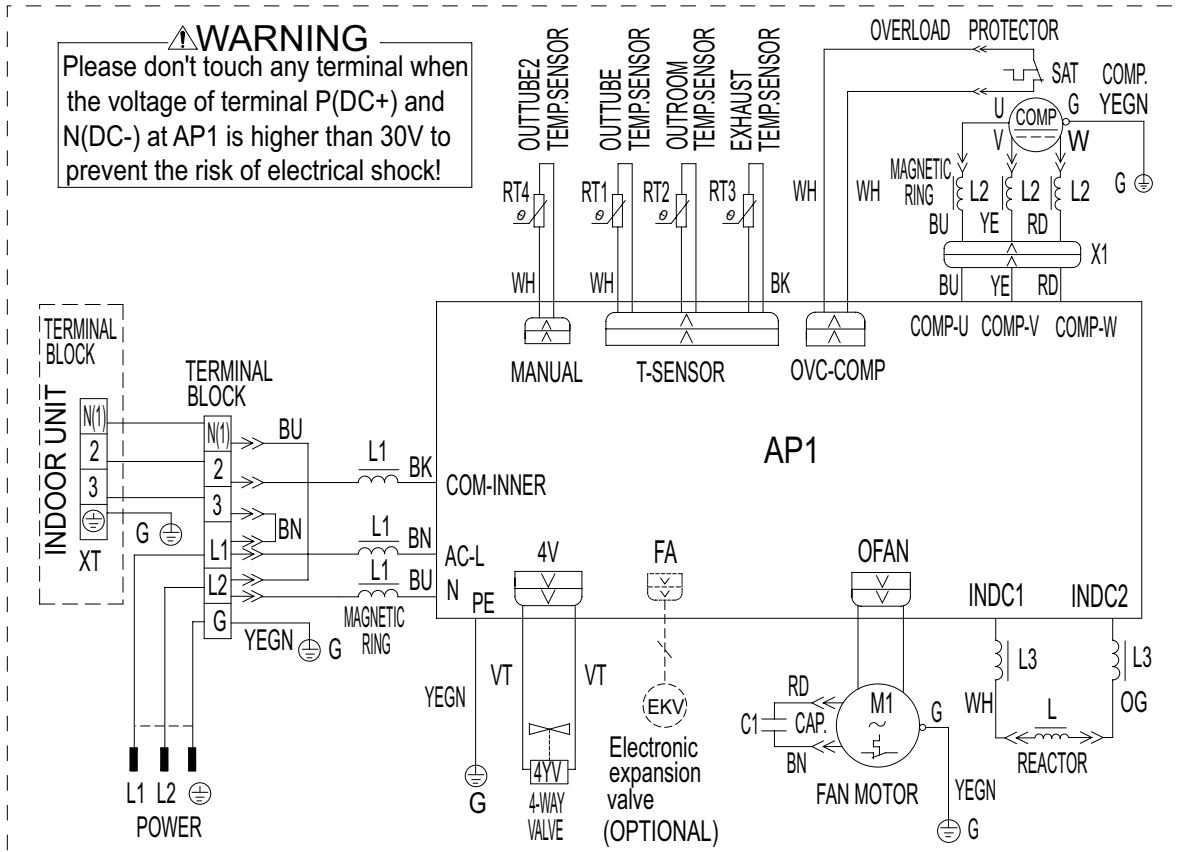

(6)GWH18MC-D3DNA3D/O(electric heating band)

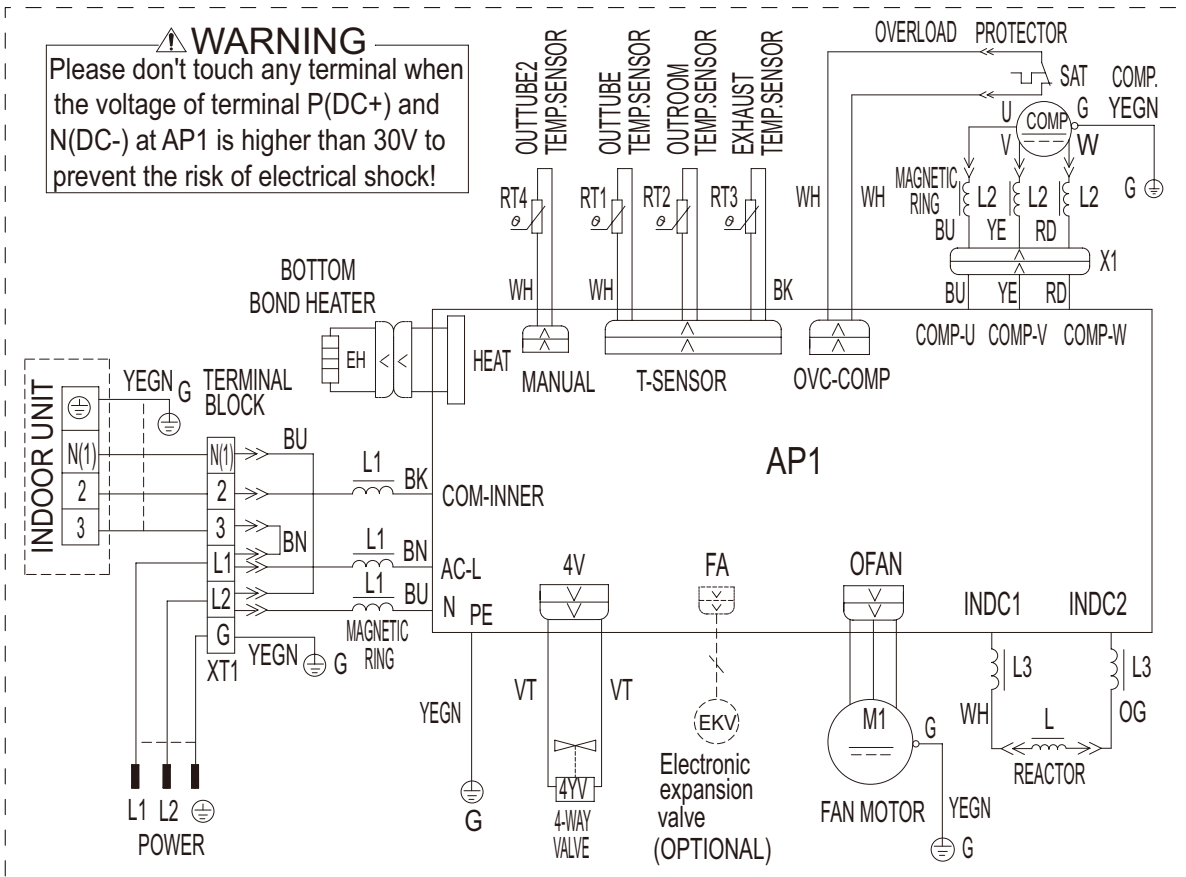

(7)GWH24MD-D3DNA3D/O(electric heating band)

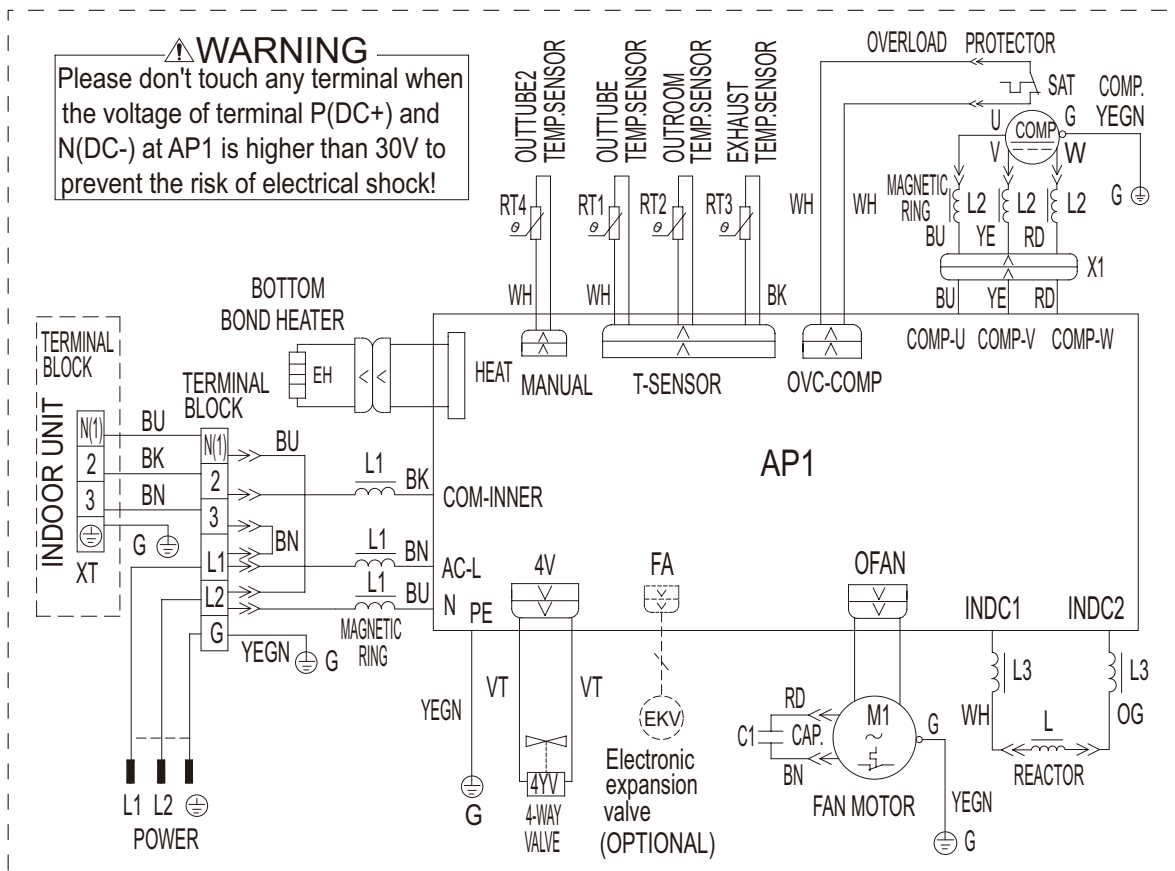

These circuit diagrams are subject to change without notice, please refer to the one supplied with the unit.

5.3 Printed Circuit Board

(1)Indoor Unit

(1)09&12K

•TOP VIEW

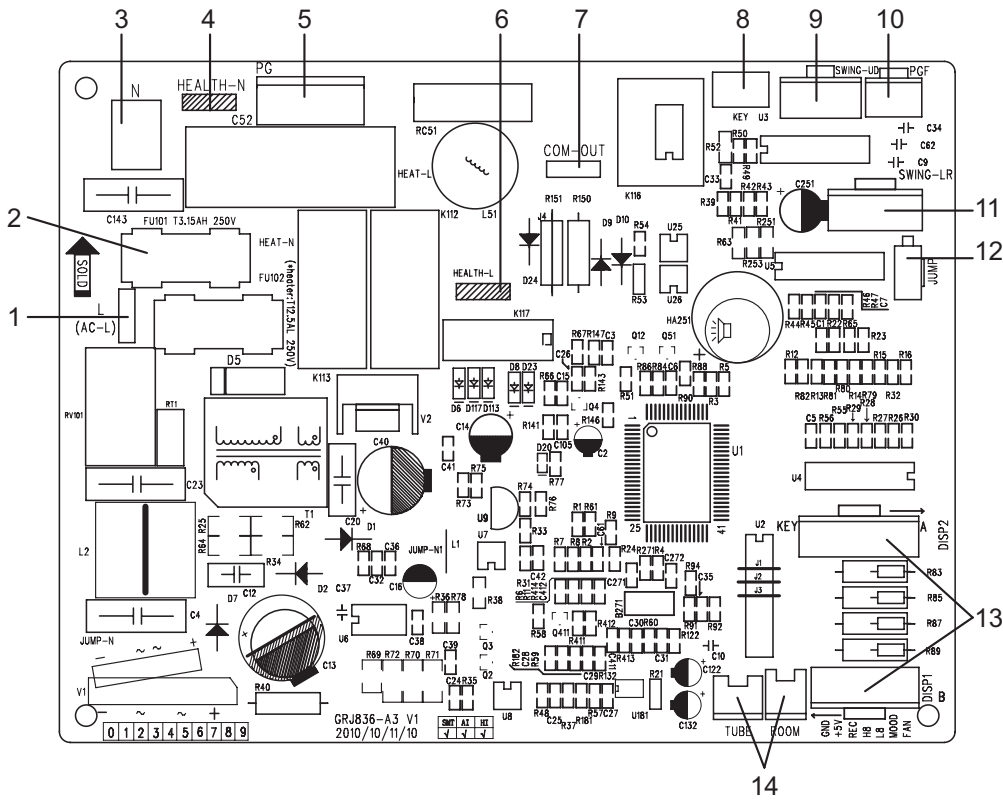

1	Live wire
2	Fuse
3	Neutral wire
4	Healthy neutral wire
5	PG motor
6	Healthy live wire
7	Neutral and live wire communication port
8	Touch switch
9	Up and down swing
10	PG feedback
11	Left and right swing
12	Jumper cap
13	Display interface
14	Temp. sensor

•BOTTOM VIEW

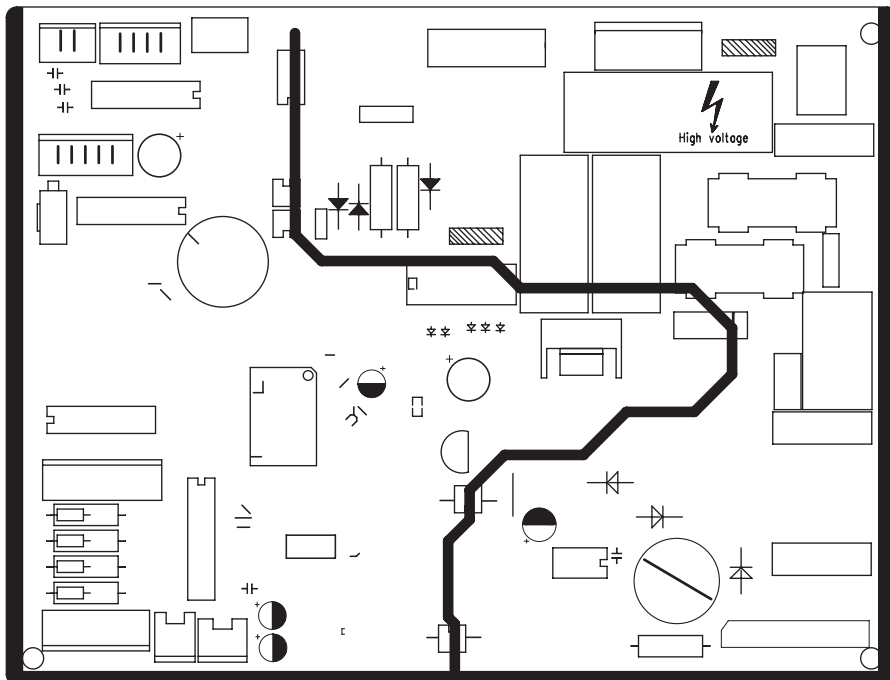

(2)18K

•TOP VIEW

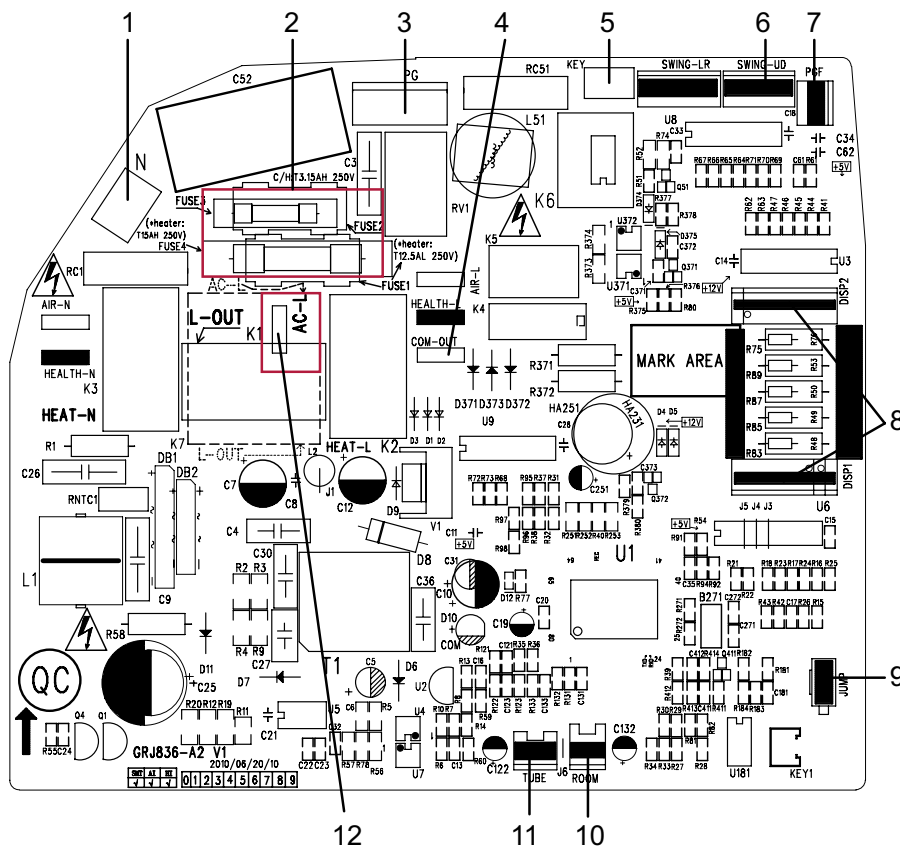

1	Neutral wire
2	Fuse
3	PG motor
4	IDU and ODU communication interface
5	Auto button
6	Up and down swing
7	PG feedback
8	Display interface
9	Jumper cap
10	Ambient temp. sensor
11	Tube temp. sensor
12	Live wire interface

•BOTTOM VIEW

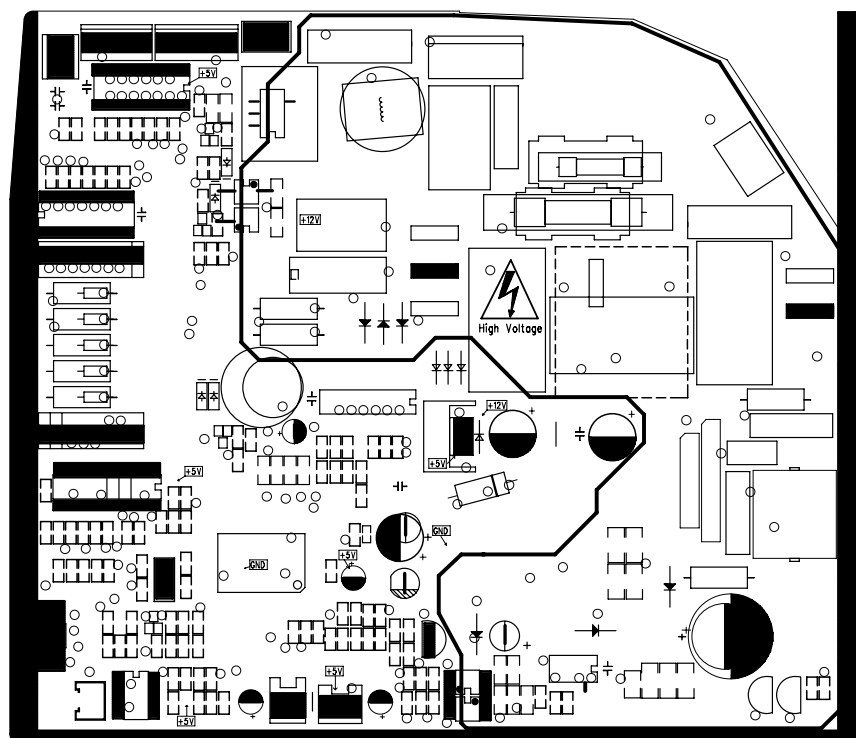

(3)24K

●TOP VIEW

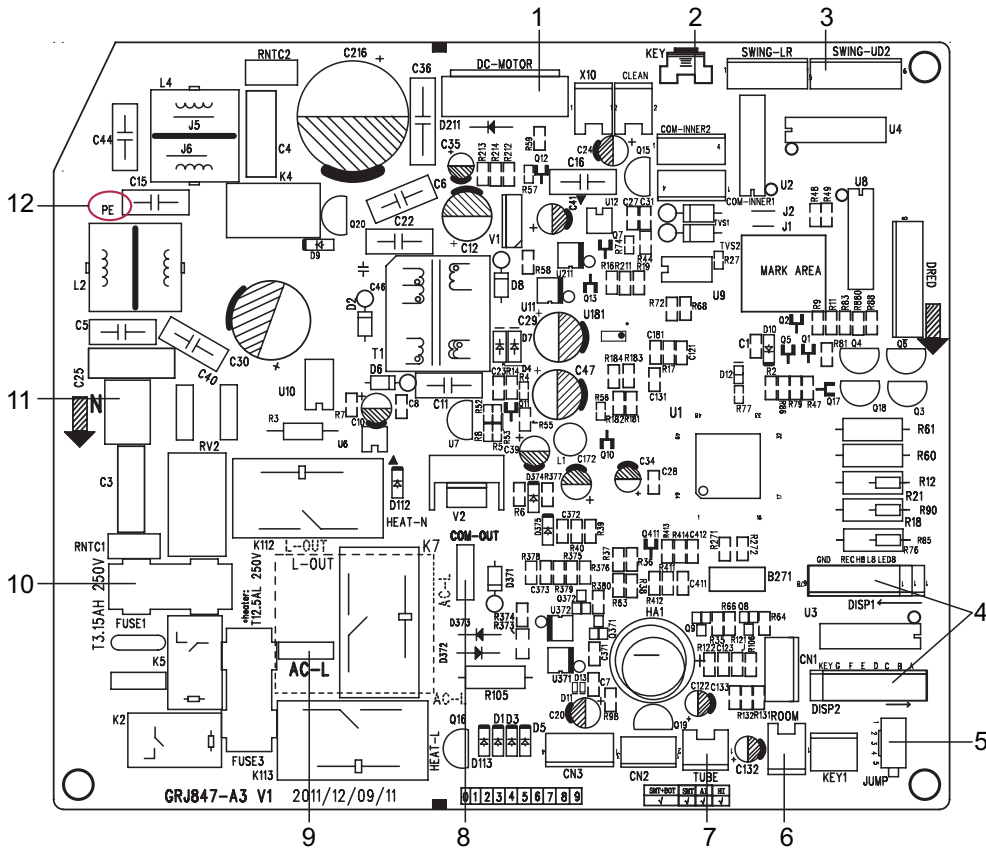

1	DC fan interface
2	Auto button
3	Up and down swing terminal interface
4	Display terminal interface
5	Jumper cap
6	Ambient temp. sensor
7	Tube temp. sensor
8	IDU and ODU communication interface
9	Live wire interface
10	Fuse
11	Neutral wire interface
12	Earth wire terminal interface

●BOTTOM VIEW

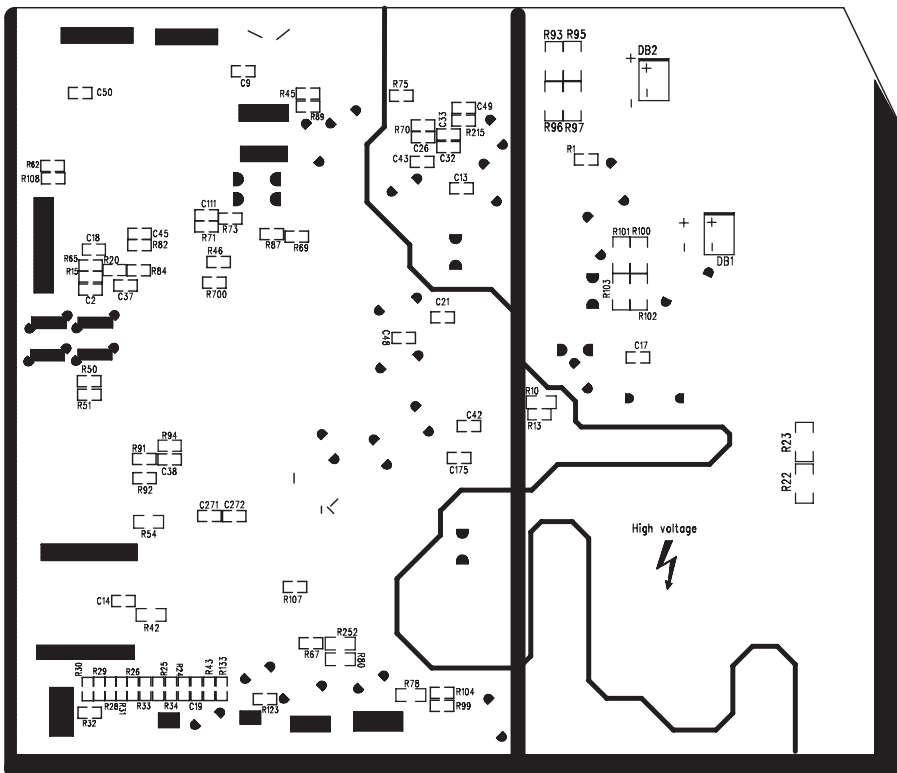

(2)Outdoor Unit

(1)09&12K

•TOP VIEW

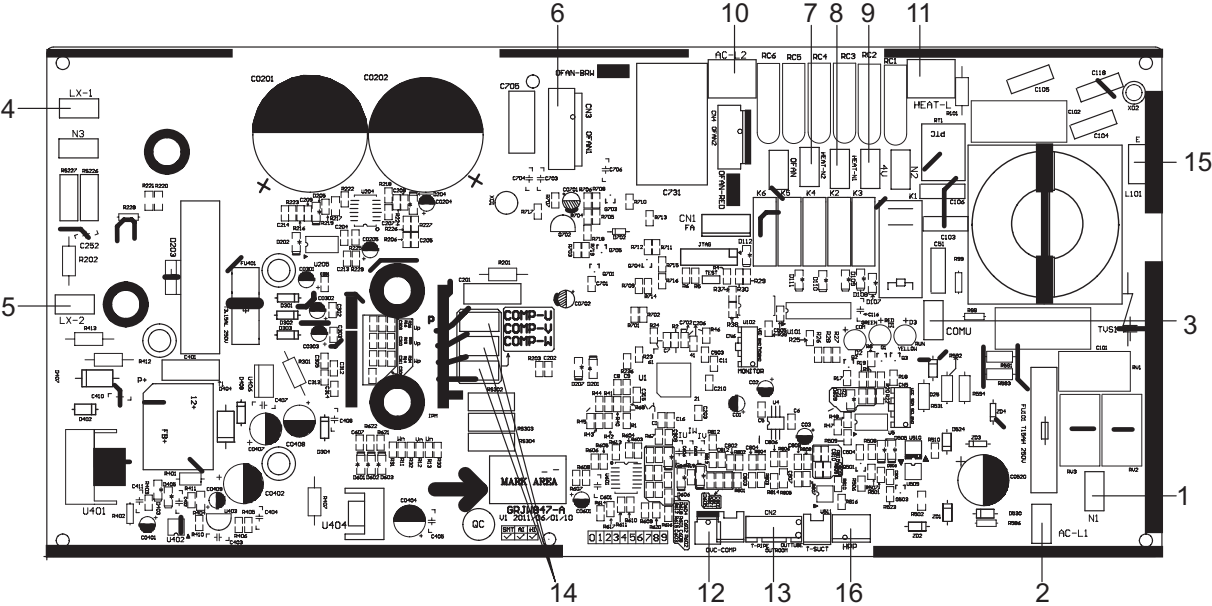

1	Power supply neutral wire input	5	Electric reactor interface 2	9	Four-way valve neutral wire	13	Temp. sensor
2	Power supply live wire input	6	Fan interface	10	Four-way valve live wire	14	Compressor U, V, W phase
3	Communication interface	7	Chassis electric heating band neutral wire	11	Electric heating with live wire	15	Power supply earth wire input
4	Electric reactor interface 1	8	Compressor electric heating band neutral wire	12	Overload input	16	Pressure switch input

•BOTTOM VIEW

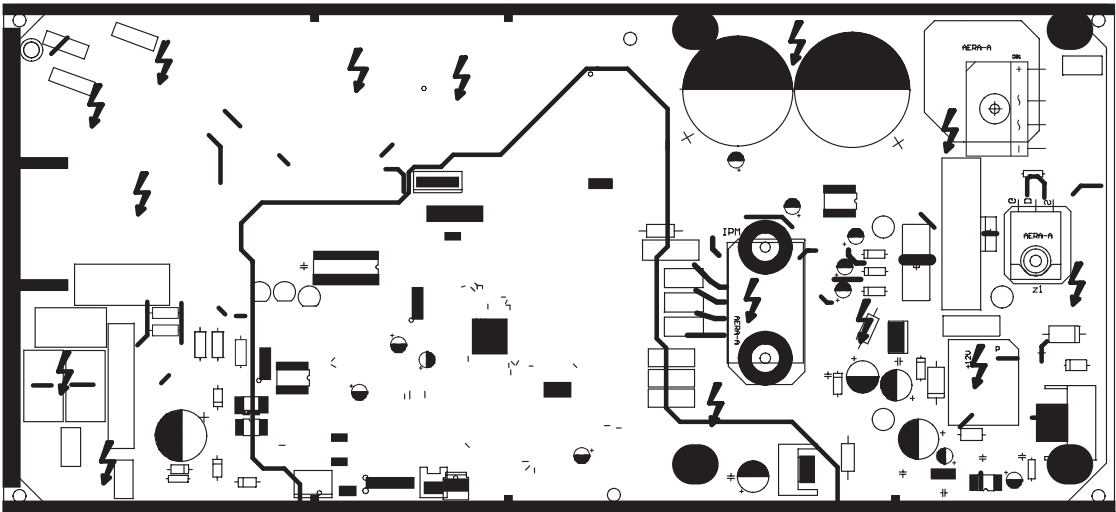

(2)18K

•TOP VIEW

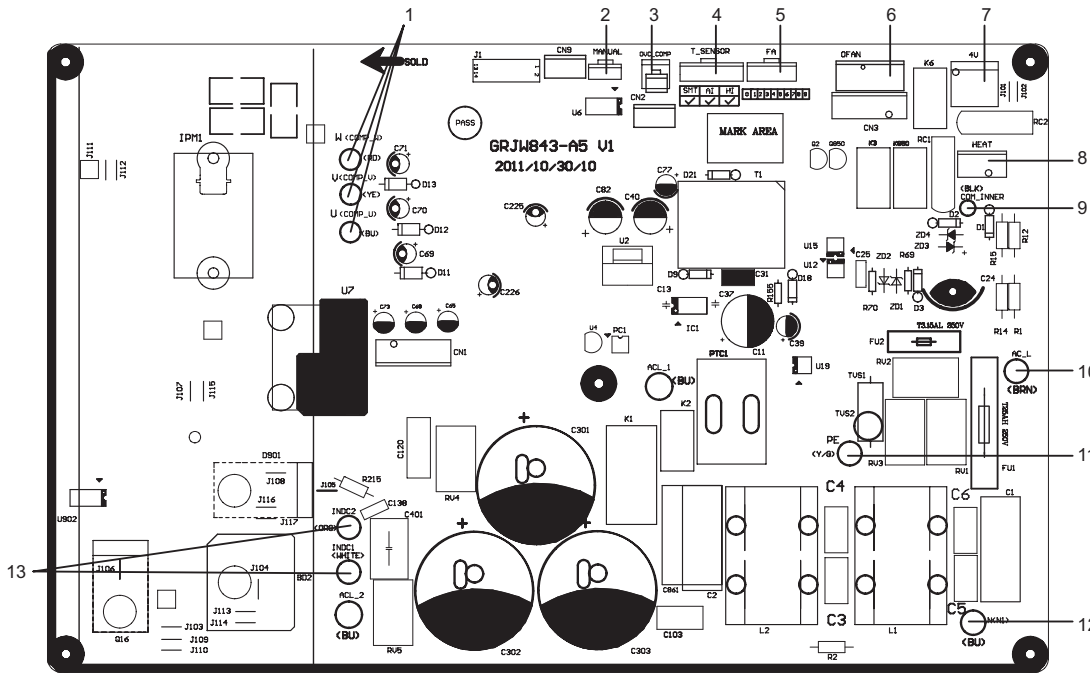

1	Compressor wiring connection terminal
2	ODU heat exchanger middle copper pipe temp. sensor terminal
3	Compressor overload protection terminal
4	ODU temp. sensor terminal
5	EXV terminal
6	Outdoor fan terminal
7	Four-way valve terminal
8	Chassis electric heating wiring terminal
9	Communication cable with IDU
10	Power supply live wire
11	Earth wire
12	Power supply neutral wire
13	PFC inductance wire

•BOTTOM VIEW

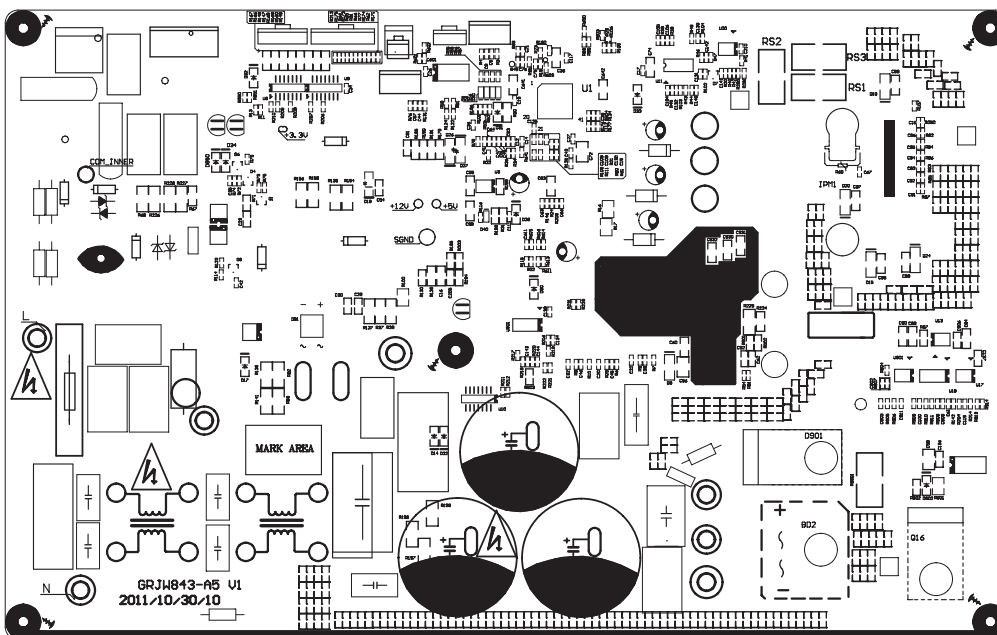

(3)24K

•TOP VIEW

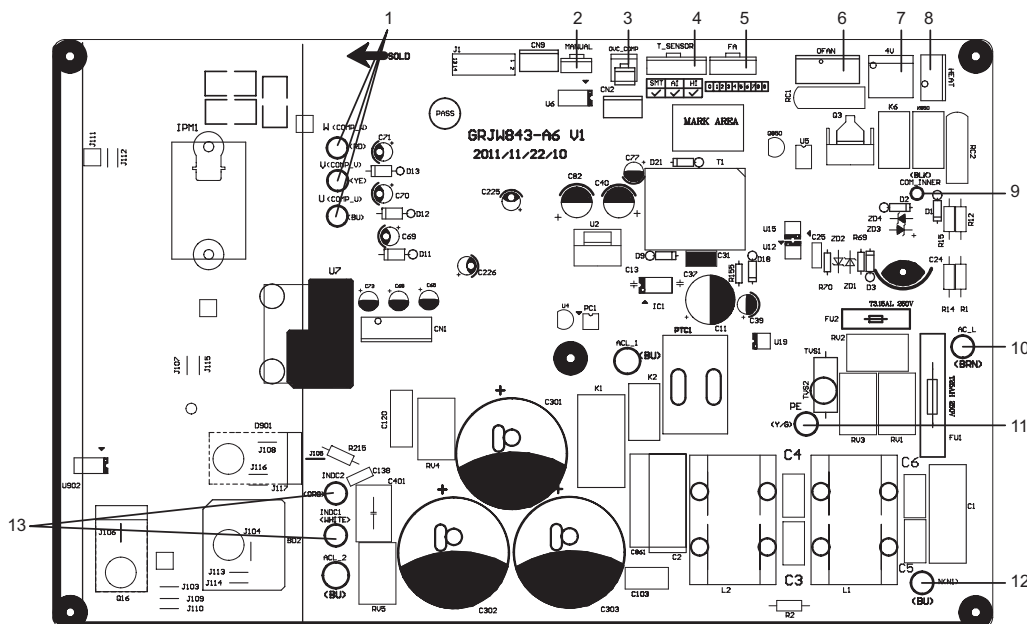

1	Compressor wiring connection terminal
2	ODU heat exchanger middle copper pipe temp. sensor terminal
3	Compressor overload protection terminal
4	ODU temp. sensor terminal
5	EXV terminal
6	Outdoor fan terminal
7	Four-way valve terminal
8	Chassis electric heating wiring terminal
9	Communication cable with IDU
10	Power supply live wire
11	Earth wire
12	Power supply neutral wire
13	PFC inductance wire

•BOTTOM VIEW

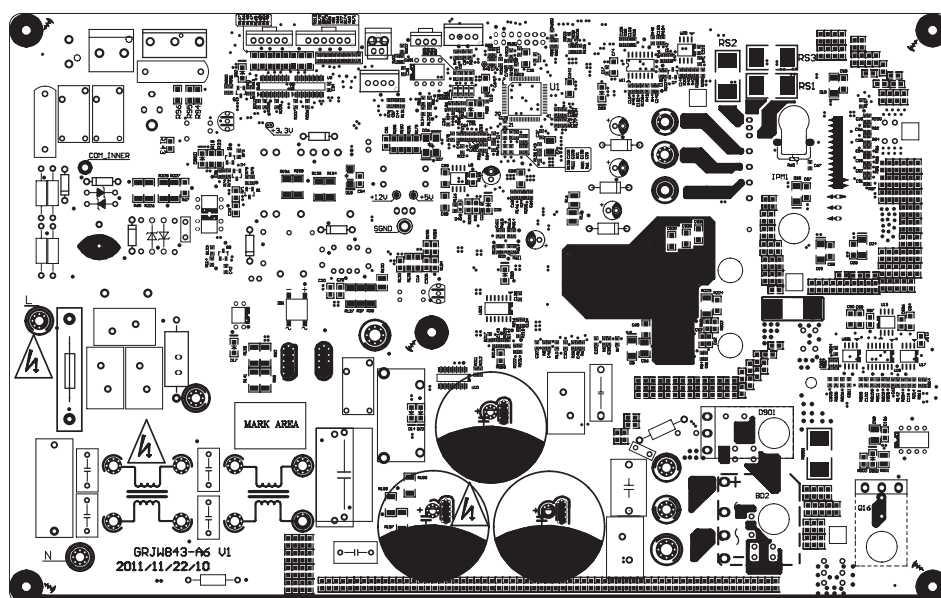









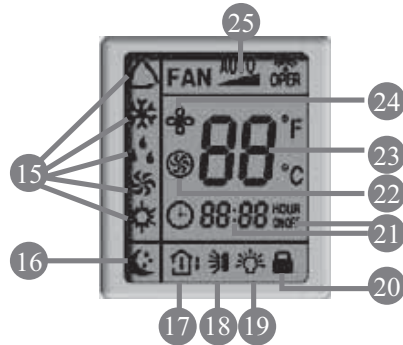

6. Function and Control

6.1 Remote Control Operations



- 1 **ON/OFF**
Press it to start or stop operation.
- 2 **MODE**
Press it to select operation mode (AUTO/COOL/DRY/FAN/HEAT).
- 3 **+**
Press it to increase temperature setting.
- 4 **-**
Press it to decrease temperature setting.
- 5 **FAN**
Press it to set fan speed.
- 6 
Press it to set swing angle.
- 7 **TIMER ON**
Press it to set auto-on timer.
- 8 **TIMER OFF**
Press it to set auto-off timer.
- 9 **CLOCK**
Press it to set clock.
- 10 **X-FAN** (X-FAN is the alternative expression of BLOW for the purpose of understanding.)
- 11 **TEMP**
- 12 **TURBO**
- 13 **SLEEP**
- 14 **LIGHT**
Press it to turn on/off the light.



- 15 **MODE icon:**
If MODE button is pressed, current operation mode icon  (AUTO),  (COOL),  (DRY),  (FAN) or  (HEAT is only for heat pump models) will show.
- 16 **SLEEP icon :**
 is displayed by pressing the SLEEP button. Press this button again to clear the display.
- 17 **TEMP icon:**
Pressing TEMP button, , ,  and blank is displayed circularly.
- 18 **Up & down swing icon:**
 is displayed when pressing the up & down swing button. Press this button again to clear the display.

19 LIGHT icon:

💡 is displayed by pressing the LIGHT button. Press LIGHT button again to clear the display.

20 LOCK icon:

🔒 is displayed by pressing "+" and "-" buttons simultaneously. Press them again to clear the display.

21 SET TIME display:

After pressing TIMER button, ON or OFF will blink. This area will show the set time.

22 TURBO icon:

⚡ is displayed when pressing the TURBO button. Press this button again to clear the display.

23 DIGITAL display:

This area will show the set temperature. In SAVE mode, "SE" will be displayed. During defrosting operation, "H1" will be displayed.

24 X-FAN icon:

🌀 is displayed when pressing the X-FAN button. Press this button again to clear the display.

25 FAN SPEED display:

Press FAN button to select the desired fan speed setting (AUTO Low-Med-High). Your selection will be displayed in the LCD windows, except the AUTO fan speed.

1 ON/OFF:

Press this button to turn on the unit. Press this button again to turn off the unit.

2 MODE:

Each time you press this button, a mode is selected in a sequence that goes from AUTO, COOL, DRY, FAN, and HEAT*, as the following:



*Note: Only for models with heating function.

After energization, AUTO mode is defaulted. In AUTO mode, the set temperature will not be displayed on the LCD, and the unit will automatically select the suitable operation mode in accordance with the room temperature to make indoor room comfortable.

3 + :

Press this button to increase set temperature. Hold it down for above 2 seconds to rapidly increase set temperature. In AUTO mode, set temperature is not adjustable.

4 -:

Press this button to decrease set temperature. Hold it down for above . 2 seconds to rapidly decrease set temperature. In AUTO mode, set temperature is not adjustable.

5 FAN :

This button is used for setting fan speed in the sequence that goes from AUTO, ◀, ▶, ▶▶ to then back to Auto.

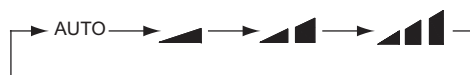

◀ Low speed ▶ Medium speed ▶▶ High speed

6 🌀

Press this button to set up & down swing angle, which circularly changes as below:



This remote controller is universal. If any command 🌀, ▶, or ▶▶ is sent out, the unit will carry out the command as 🌀

🌀 indicates the guide louver swings as:





7 TIMER ON:

Press this button to initiate the auto-ON timer. To cancel the auto-timer program, simply press this button again. After pressing this button,  disappears and "ON" blinks. 0 0:00 is displayed for ON time setting. Within 5 seconds, press + or - button to adjust the time value. Every press of either button changes the time setting by 1 minute. Holding down either button rapidly changes the time setting by 1 minute and then 10 minutes. Within 5 seconds after setting, press TIMER ON button to confirm.

8 TIMER OFF:

Press this button to initiate the auto-off timer. To cancel the auto-timer program, simply press the button again. TIMER OFF setting is the same as TIMER ON.

9 CLOCK :

Pressing CLOCK button,  blinks. Within 5 seconds, pressing + or - button adjusts the present time. Holding down either button above 2 seconds increases or decreases the time by 1 minute every 0.5 second and then by 10 minutes every 0.5 second. During blinking after setting, press CLOCK button again to confirm the setting, and then  will be constantly displayed.

10 X-FAN:

Pressing X -FAN button in COOL or DRY mode, the icon  is displayed and the indoor fan will continue operation for 10 minutes in order to dry the indoor unit even though you have turned off the unit.

After energization, X-FAN OFF is defaulted. X-FAN is not available in AUTO, FAN or HEAT mode.

11 TEMP:

Press this button, could select displaying the indoor setting temperature or indoor ambient temperature. When the indoor unit firstly power on it will display the setting temperature, if the temperature's displaying status is changed from other status to "  ", displays the ambient temperature, 5s later or within 5s, it receives other remote control signal that will return to display the setting temperature. If the users haven't set up the temperature displaying status, that will display the setting temperature.



12 TURBO:

Press this button to activate / deactivate the Turbo function which enables the unit to reach the preset temperature in the shortest time. In COOL mode, the unit will blow strong cooling air at super high fan speed. In HEAT mode, the unit will blow strong heating air at super high fan speed.



13 SLEEP:



Press this button to go into the SLEEP operation mode. Press it again to cancel this function. This function is available in COOL, HEAT (Only for models with heating function) or DRY mode to maintain the most comfortable temperature for you.

14 LIGHT:

Press LIGHT button to turn on the display's light and press this button again to turn off the display's light. If the light is turned on,  is displayed. If the light is turned off,  disappears.

15 Combination of "+" and "-" buttons: About lock

Press "+" and "-" buttons simultaneously to lock or unlock the keypad. If the remote controller is locked,  is displayed. In this case, pressing any button,  blinks three times.

16 Combination of "MODE" and "-" buttons: About switch between Fahrenheit and Centigrade At unit OFF, press "MODE" and "-" buttons simultaneously to switch between  and .

Replacement of Batteries

1. Remove the battery cover plate from the rear of the remote controller.

(As shown in the figure)

2. Take out the old batteries.

3. Insert two new AAA1.5V dry batteries, and pay attention to the polarity.

4. Reinstall the battery cover plate.

Notes:

- When replacing the batteries, do not use old or different types of batteries. Otherwise, it may cause malfunction.
- If the remote controller will not be used for a long time, please remove batteries to prevent batteries from leaking.
- The operation should be performed in its receiving range.
- It should be kept 3.3ft. away from the TV set or stereo sound sets.
- If the remote controller does not operate normally, please take the batteries out and reinsert them after 30 seconds. If it still can't operate properly, replace the batteries.

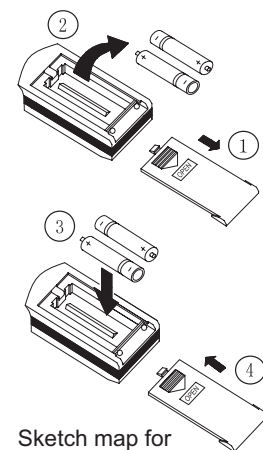

Sketch map for replacing batteries

6.2 Description of Each Control Operation

For 09、12K Unit

1. Temperature Parameters

- ◆ Indoor preset temperature (T_{preset})
- ◆ Indoor ambient temperature ($T_{\text{amb.}}$)

2. Basic Functions

Once energized, in no case should the compressor be restarted within less than 3 minutes. In the situation that memory function is available, for the first energization, if the compressor is at stop before de-energization, the compressor will be started without a 3-minute lag; if the compressor is in operation before de-energization, the compressor will be started with a 3-minute lag; and once started, the compressor will not be stopped within 6 minutes regardless of changes in room temperature;

(1) Cooling Mode

① Working conditions and process of cooling

When $T_{\text{amb.}} \geq T_{\text{preset}}$, the unit will enter cooling operation, in which case the indoor fan, the outdoor fan and the compressor will work and the indoor fan will run at preset speed.

When $T_{\text{amb.}} = T_{\text{preset}} - 35.6^\circ\text{F}$, the compressor will run in 15Hz for continuous 15 minutes; if $T_{\text{amb.}} = T_{\text{preset}} - 35.6^\circ\text{F}$ is not changed after that, the compressor will stop to run;

When $T_{\text{amb.}} \leq T_{\text{preset}} - 37.4^\circ\text{F}$, the compressor will stop to run, the outdoor fan motor will stop to run after 30 seconds and the indoor fan motor will run at set fan speed;

When $T_{\text{preset}} - 35.6^\circ\text{F} < T_{\text{amb.}} < T_{\text{preset}}$, the unit will keep the previous running status.

Under this mode, the four-way valve will be de-energized and temperature can be set within a range from 60.8 to 86°F.

If the compressor is shut down for some reason, the indoor fan and the swing device will operate at original state.

② Protection

◆ Antifreeze protection

Under cooling and dehumidifying mode, 6 minutes after the compressor is started:

If $T_{\text{evap}} \leq 35.6^\circ\text{F}$, the compressor will operate at reduced frequency.

If $T_{\text{evap}} \leq 30.2^\circ\text{F}$ is detected for durative 3 minutes, the compressor will stop, and after 30 seconds, the outdoor fan will stop; and under cooling mode, the indoor fan and the swing motor will remain at the original state.

If $T_{\text{evap.}} \geq 50^\circ\text{F}$ and the compressor has remained at OFF for at least 3 minutes, the compressor will resume its original operation state.

◆ Total current up and frequency down protection

When total current $I_{\text{total}} \leq 6\text{A}$, increase frequency is allowed; when total current $I_{\text{total}} \geq 7\text{A}$, increasing frequency is prohibited; when total current $I_{\text{total}} \geq 8\text{A}$, the unit operates by decreasing frequency. When total current $I_{\text{total}} \geq 9\text{A}$, the compressor stops operation, and indoor fan will stop operation after 30s.

(2) Dehumidifying Mode

① Working conditions and process of dehumidifying

If $T_{\text{amb.}} > T_{\text{preset}}$, the unit will enter cooling and dehumidifying mode, in which case the compressor and the outdoor fan will operate and the indoor fan will run at low speed.

If $T_{\text{preset}} - 35.6^\circ\text{F} \leq T_{\text{amb.}} \leq T_{\text{preset}}$, the compressor remains at its original operation state.

If $T_{\text{amb.}} < T_{\text{preset}} - 35.6^\circ\text{F}$, the compressor will stop, the outdoor fan will stop with a time lag of 30s, and the indoor fan will operate at low speed.

② Protection

Protection is the same as that under the cooling mode.

((3) Heating Mode

① Working conditions and process of heating

① If $T_{\text{preset}} - (T_{\text{indoor ambient}} - T_{\text{compensatory}}) \geq 33.8^\circ\text{F}$, the unit enters heating mode, in which case the compressor, the outdoor fan and the 4-way valve will operate simultaneously;

② If $28.4^\circ\text{F} < T_{\text{preset}} - (T_{\text{indoor ambient}} - T_{\text{compensatory}}) < 33.8^\circ\text{F}$, the unit will maintain its original operating status.

③ If $T_{\text{preset}} - (T_{\text{indoor ambient}} - T_{\text{compensatory}}) \leq 28.4^\circ\text{F}$, the compressor will stop and the outdoor fan will stop with a time lag of 30s;

④ If turning off the unit when the unit is in heating mode or switching heating mode to another mode, the 4-way valve will be powered off after the compressor stops for 2min (the compressor has already started in heating mode).

⑤ If $T_{\text{outdoor ambient}} > 86^\circ\text{F}$, the compressor will stop and the outdoor fan will stop with a time lag of 30s

⑥ When the compressor has started, if switching cooling or dry mode to heating mode, the 4-way valve will be energized with a time lag of 2-3min.

Note: $T_{\text{compensatory}}$ is determined by indoor unit and outdoor unit. If the indoor unit controls $T_{\text{compensatory}}$, $T_{\text{compensatory}}$ is determined by the data sent by indoor unit to outdoor unit; if the indoor unit doesn't control $T_{\text{compensatory}}$, the outdoor unit will control $T_{\text{compensatory}}$ and the default data is 37.4°F. (there is instruction in the communication protocol to describe if the $T_{\text{compensatory}}$ is controlled by indoor unit)

② Condition and process of defrost

(1) When Toutdoor ambient $\leq 41^{\circ}\text{F}$ and the compressor has run for 3h, if Toutdoor tube $< 32^{\circ}\text{F}$ is continuously detected for 1min, the unit will enter defrosting; [Note: the accumulated time is cleared if one of the below condition is met: Toutdoor ambient $> 41^{\circ}\text{F}$, the compressor starts up after switching to cooling or dry mode, when defrosting is finished; for other situations besides above conditions, the accumulated time will not be cleared (including the unit stops when reaching the temperature point, the unit stops for protection, switching to fan mode, etc.)]

(2) When duration of successive heating operation is more than 45 minutes, or accumulated heating time more than 90 minutes, and one of the following conditions is reached, the unit will enter the defrost mode after 3 minutes:

- Toutdoor ambient $> 41^{\circ}\text{F}$, Toutdoor tube $\leq 28.4^{\circ}\text{F}$;
- $28.4^{\circ}\text{F} \leq \text{Toutdoor ambient} < 41^{\circ}\text{F}$, Toutdoor tube $\leq 21.2^{\circ}\text{F}$;
- $23^{\circ}\text{F} \leq \text{Toutdoor ambient} < 28.4^{\circ}\text{F}$, Toutdoor tube $\leq 17.6^{\circ}\text{F}$;
- $14^{\circ}\text{F} \leq \text{Toutdoor ambient} < 23^{\circ}\text{F}$, Toutdoor tube - Tcompensatory $\leq (\text{Toutdoor ambient} - 37.4^{\circ}\text{F})$
- Toutdoor ambient $< 14^{\circ}\text{F}$, Toutdoor tube - Tcompensatory $\leq (\text{Toutdoor ambient} - 37.4^{\circ}\text{F})$

After energization, for the first defrosting, Tcompensation = 32°F ; if it is not the first time of defrosting, Tcompensation will be determined by Toutdoor pipe when quitting defrosting last time;

- Toutdoor pipe $> 35.6^{\circ}\text{F}$, Tcompensation = 32°F ;
- Toutdoor pipe $\leq 35.6^{\circ}\text{F}$, Tcompensation = 37.4°F .

(3) During defrosting, if operation time for compressor doesn't reach 3min, the defrosting will not be entered in the subsequent 2 hours. At that time, compressor stops operation and in 30s later, the outdoor fan will stop operation; in another 30s, 4-way valve will stop operation; in 30s later, compressor will increase its frequency for defrosting. When defrosting lasts for 450s, or Toutdoor pipe $\geq 50^{\circ}\text{F}$, compressor will decrease its frequency. In 30s later, compressor will stop operation; in another 30s, 4-way valve will be started up. In 60s later, compressor and outdoor fan will operate. Frequency for defrosting is 85Hz.

③ Protection

◆ Cold air prevention

The unit is started under heating mode (the compressor is ON):

① In the case of T indoor amb. $< 75.2^{\circ}\text{F}$: if T tube $\leq 104^{\circ}\text{F}$ and the indoor fan is at stop state, the indoor fan will begin to run at low speed with a time lag of 2 minutes. Within 2 minutes, if T tube $> 104^{\circ}\text{F}$, the indoor fan also will run at low speed; and after 1-minute operation at low speed, the indoor fan will be converted to operation at preset speed. Within 1-minute low speed operation or 2-minute non-operation, if T tube $> 107.6^{\circ}\text{F}$, the fan will run at present speed.

② In the case of T indoor amb. $\geq 75.2^{\circ}\text{F}$: if T tube $\leq 107.6^{\circ}\text{F}$, the indoor fan will run at low speed, and after one minute, the indoor fan will be converted to preset speed. Within one-minute low speed operation, if T tube $> 107.6^{\circ}\text{F}$, the indoor fan will be converted to preset speed.

Note: T indoor amb. indicated in ① and ② refers to, under initially heating mode, the indoor ambient temperature before the command to start the compressor is performed according to the program, or after the unit is withdrawn from defrost, the indoor ambient temperature before the defrost symbol is cleared.

◆ Total current up and frequency down protection

When total current $I_{\text{total}} \leq 6\text{A}$, increase frequency is allowed; when total current $I_{\text{total}} \geq 7\text{A}$, increasing frequency is prohibited; when total current $I_{\text{total}} \geq 8\text{A}$, the unit operates by decreasing frequency. When total current $I_{\text{total}} \geq 9\text{A}$, the compressor stops operation, and indoor fan will stop operation after 30s.

(4) Fan Mode

Under the mode, the indoor fan will run at preset speed and the compressor, the outdoor fan, the four-way valve and the electric heater will stop.

Under the mode, temperature can be set within a range of $60.8 - 86^{\circ}\text{F}$.

(5) AUTO Mode

① Working conditions and process of AUTO mode

a. When T ambient $\geq 78.8^{\circ}\text{F}$, the unit will operate in Cool mode. The set temperature is 77°F .

b. When T ambient $\leq 71.6^{\circ}\text{F}$, the heat pump unit will operate in Heat mode., set temperature be 68°F ; the cooling only unit will operate in Fan mode, set temperature be 77°F .

c. When $73.4^{\circ}\text{F} \leq \text{T ambient} \leq 77^{\circ}\text{F}$, the unit will operate in the previous state. If it is energized for the first time, it will operate in Fan mode.

d. Under auto mode, if it's cooling mode, operation frequency is same as that under cooling mode; if it's heating mode, operation frequency is same as that under heating mode.

② Protection

a. In cooling operation, protection is the same as that under the cooling mode;

b. In heating operation, protection is the same as that under the heating mode;

c. When ambient temperature changes, operation mode will be converted preferentially. Once started, the compressor will remain unchanged for at least 6 minutes.

(6) Common Protection Functions and Fault Display under COOL, HEAT, DRY and AUTO Modes

① Overload protection

T tube: measured temperature of outdoor heat exchanger under cooling mode; and measured temperature of indoor heat exchanger under heating mode.

1) Cooling overload

- a. If T tube $\leq 125.6^{\circ}\text{F}$, the unit will return to its original operation state.
- b. If T tube $\geq 131^{\circ}\text{F}$, frequency rise is not allowed.
- c. If T tube $\geq 136.4^{\circ}\text{F}$, the compressor will run at reduced frequency.
- d. If T tube $\geq 143.6^{\circ}\text{F}$, the compressor will stop and the indoor fan will run at preset speed.

2) Heating overload

- a. If T tube $\leq 122^{\circ}\text{F}$, the unit will return to its original operation state.
- b. If T tube $\geq 127.4^{\circ}\text{F}$, frequency rise is not allowed.
- c. If T tube $\geq 132.8^{\circ}\text{F}$, the compressor will run at reduced frequency.
- d. If T tube $\geq 140^{\circ}\text{F}$, the compressor will stop and the indoor fan will blow residue heat and then stop.

② Exhaust temperature protection of compressor

If exhaust temperature $\geq 208.4^{\circ}\text{F}$, frequency is not allowed to rise.

If exhaust temperature $\geq 217.4^{\circ}\text{F}$, the compressor will run at reduced frequency.

If exhaust temperature $\geq 230^{\circ}\text{F}$, the compressor will stop.

If exhaust temperature $\leq 194^{\circ}\text{F}$ and the compressor has stayed at stop for at least 3 minutes, the compressor will resume its operation.

③ Communication fault

If the unit fails to receive correct signals for durative 3 minutes, communication fault can be justified and the whole system will stop.

④ Module protection

Under module protection mode, the compressor will stop. When the compressor remains at stop for at least 3 minutes, the compressor will resume its operation. If module protection occurs six times in succession, the compressor will not be started again.

⑤ Overload protection

If temperature sensed by the overload sensor is over 239°F , the compressor will stop and the outdoor fan will stop with a time lag of 30 seconds. If temperature is below 203°F , the overload protection will be relieved.

⑥ DC bus voltage protection

If voltage on the DC bus is below 150V or over 420V, the compressor will stop and the outdoor fan will stop with a time lag of 30 seconds. When voltage on the DC bus returns to its normal value and the compressor has stayed at stop for at least 3 minutes, the compressor will resume its operation.

3. Other Controls

(1) ON/OFF

Press the remote button ON/OFF: the on-off state will be changed once each time you press the button.

(2) Mode Selection

Press the remote button MODE, then select and show in the following ways: AUTO, COOL, DRY, FAN, HEAT, AUTO.

(3) Temperature Setting Option Button

Each time you press the remote button TEMP+ or TEMP-, the setting temperature will be up or down by 33.8°F . Regulating Range: $60.8 - 86^{\circ}\text{F}$, the button is useless under the AUTO mode.

(4) Time Switch

You should start and stop the machine according to the setting time by remote control.

(5) SLEEP State Control

a. When the air conditioner is under the mode of COOL, DRY, and the SLEEP mode has been set well, after the SLEEP state keeps about 1 hour, the pre-setting T will raise 33.8°F , and it will raise 33.8°F again after 2 hours, so it raise 35.6°F in 2 hours, then it will run on at the setting temperature and wind speed.

b. When the air conditioner is under the mode of HEAT, and the Timer has been set well, after the SLEEP state keeps about 1 hour, the pre-setting T will reduce 33.8°F , and it will reduce 33.8°F again after 2 hours, so it reduce 35.6°F in 2 hours, then it will run on at the setting temperature and wind speed.

c. The setting temperature keeps the same under the FAN mode and AUTO mode.

(6) Indoor Fan Control

The Indoor Fan can be set as HIGH, MED, LOW by remote control, and the Indoor Fan will be respectively run at high, medium, low speed. It will also be set as AUTO, and the Indoor Fan is as the followings at the automatic wind speed.

Cooling mode:

- T ring \geq T setting + 35.6°F, high speed;
- T setting - 35.6°F < T ring < T setting + 35.6°F, medium speed;
- T ring \leq T setting - 35.6°F, low speed.

Sending wind mode:

- T ring > T setting + 39.2°F, high speed;
- T setting + 35.6°F \leq T ring \leq T setting + 39.2°F, medium speed;
- T ring < T setting + 35.6°F, low speed.

Moisture removal mode: force to be set as the low speed

Heating mode:

- T ring \leq T setting + 33.8°F, high speed;
- T setting + 33.8°F < T ring < T setting + 41°F, medium speed;
- T ring \geq T setting + 35.6°F, low speed.

(7) Buzzer Control

The buzzer will send a “Di” sound when the air conditioner is powered up or received the information sent by the remote control or there is a button input, the single tube cooler doesn’t receive the remote control ON signal under the mode of heating mode.

(8) Auto button

If the controller is on, it will stop by pressing the button, and if the controller is off, it will be automatic running state by pressing the button, swing on and light on, and the main unit will run based on the remote control if there is remote control order.

(9) Up-and-Down Swinging Control

When power on, the up-and-down motor will firstly move the air deflector to counter-clockwise, close the air outlet. After starting the machine, if you don’t set the swinging function, heating mode and auto-heating mode, the up-and-down air deflector will move to D clockwise; under other modes, the up-and-down air deflector will move to L1. If you set the swinging function when you start the machine, then the wind blade will swing between L and D. The air deflector has 7 swinging states: Location L, Location A, Location B, Location C, Location D, Location L to Location D, stop at any location between L-D (the included angle between L~D is the same). The air deflector will be closed at 0 Location, and the swinging is effectual only on condition that setting the swinging order and the inner fan is running. The indoor fan and compressor may get the power when air deflector is on the default location.

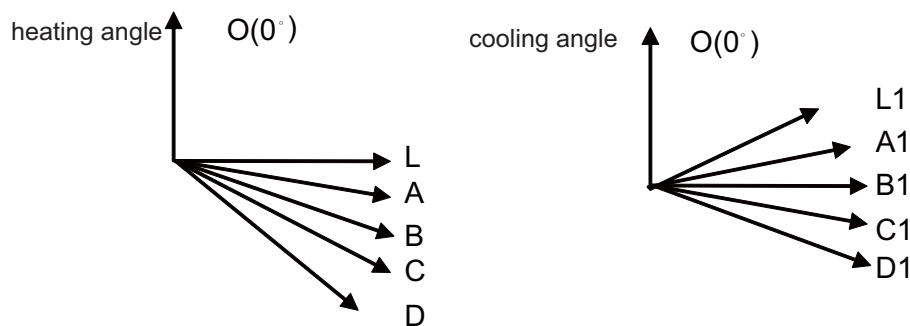

(10) Display

① Operation pattern and mode pattern display

All the display patterns will display for a time when the power on, the operation indication pattern will display in red under standby status. When the machine is start by remote control, the indication pattern will light and display the current operation mode (the mode light includes: Cooling, heating and dehumidify). If you close the light key, all the display patterns will close.

② Double-8 display

According to the different setting of remote control, the nixie light may display the current temperature (the temperature scope is from 60.8 to 86°F) and indoor ambient temperature. The heating and air supply temperature will display 77°F under auto-mode, the temperature will display 64.4°F, under the heating mode, and the temperature will display H1 under the defrosting mode.(If you set the fahrenheit temperature display, the nixie light will display according to fahrenheit temperature)

(11) Drying Function

You may start or stop the drying function under the modes of cooling and dehumidify at the starting status (The modes of automatism, heating and air supply do not have drying function). When you start the drying function, after stop the machine by pressing the switch button, you should keep running the inner fans for 10 minutes under low air damper (The swing will operate as the former status within 10 minutes, and other load is stopped), then stop the entire machine; When you stop the drying function, press the switch button will stop the machine directly. When you start the drying function, operating the drying button will stop the inner fans and close the guide louver.

(12) Memory function when interrupting the power supply

Memory content: mode, swing function, light, set temperature and wind speed. After interrupted the power supply, the machine will start when recovering the power according to the memory content automatically. If the last remote control command has not set the timed function, the system will remember the last remote control command and operate according it. If the last remote control command has set timed function and the power supply is interrupted before the timed time, the system will remember the timed function of the last remote control command, the timed time will recounted form power on. If the last remote control command has set timed function, the time is out and the system is start or stop according to the set time when the power supply is interrupted, the system will remember the operation status before the power supply was interrupted, and do not carry out timed action; The timed clock will not remembered.

(13)Control of Outdoor Electric Heating Band

If not in heating mode or temp sensor has malfunction, electric heating bands of compressor and of condenser will stop operation, otherwise, the below control logic will be followed.

1. Control of Compressor Electric Heating Band

a) Startup condition: compressor is powered off while outdoor ambient temperature $\leq 23^{\circ}\text{F}$;

b) Stop condition: the compressor will be turned off under any of the condition;

i. Compressor is powered on:

ii. Compressor is powered off while outdoor ambient temperature $\geq 28.4^{\circ}\text{F}$;

c) Outdoor ambient temp. sensor is with malfunction, the electric heating band will stop operation.

2. Condenser electric heating band control

1) When Toutdoor ambient $\leq 33.8^{\circ}\text{F}$, the condenser electric heating band will start operation;

2) The chassis electric heating band will operate during the course from the unit starts defrosting to defrosting finished and the compressor start

operation, after 3mins operation of compressor and Toutdoor ambient $\geq 37.4^{\circ}\text{F}$, electric heating stop operation.

3) When Toutdoor ambient $\geq 37.4^{\circ}\text{F}$, condenser electric heating band stop operation.

4) When $33.8^{\circ}\text{F} < \text{Toutdoor ambient} < 37.4^{\circ}\text{F}$, condenser electric heating band keep its original status.

When there's malfunction of outdoor ambient temp. sensor, the electric heating band stop operation and restart operation 2mins later.

For 18、24K Unit

Indoor Part

1. Basic function of system

(1) Cooling mode

1. Under this mode, fan motor, swing will work under setting status, the temp. range is 61-86

2. Outdoor unit malfunction or unit stop running, indoor unit will keep original running status, malfunction displayed.

3. When $0(T_{set}-T_{amb})$, if indoor fan motor is high speed, that the fan motor is running in middle speed, the middle speed or low speed will be maintained; (this condition should be executed when compressor start up); the super high speed will not rotate; When $(T_{amb}-T_{set}) \geq 33.8^{\circ}\text{F}$ the fan will return to the setting fan speed.

(2) Drying mode

1. Under this mode, fan motor will run at low speed, swing will work at setting status, setting temp. range is 61-86 °F.

2. Outdoor unit malfunction or protection, unit will stop, indoor unit will keep original running status, malfunction displayed.

(3) Fan mode

Under this mode, indoor fan motor could be set at high, middle, low or auto speed, compressor, outdoor unit and valve will stop to run.

Under this mode, temp. range should be 61-86 °F.

(4) Heating mode

1. Under this mode, temp. range should be 61-86 °F.

2. Working condition and procedure of heating mode: When unit turn on and enter into Heating mode, indoor unit enter into anti-cool wind mode, when unit is stop running, and indoor fan motor turns on, blowing heat will act. 3. Protection function, under heating mode, compressor will stop to run due to malfunction happened, indoor fan motor will blow surplus heat.

4. Defrosting control: When receiving the defrosting signal from outdoor unit, displayer will display H1, 10s later, indoor fan motor will stop to run.

5. Anti-cool wind function

6. Blow heat air function

a. If heating temp. meets the compressor stop running condition, compressors, outdoor fan motor will stop to run, the upper and lower guide louver will rotate to horizontal position L, indoor fan motor run at setting fan speed for 60s, then the indoor fan motor will stop to run.

b. Due to 内风机 block running, the air guide board will keep the position when it stopping. (under each mode),

other malfunction unit will stop to run, the upper and lower air guide louver will rotate to horizontal position L, indoor fan unit will run at setting fan speed and run for 60s, indoor fan unit will stop to run.

(5) Auto mode

1. When $T_{amb} \geq 78.8^{\circ}\text{F}$, select the cooling mode, at this time, the setting temp. is 77 °F.

2. Cooling and heating units: $T_{amb} \leq 71.6^{\circ}\text{F}$. will run at heating mode, at this time, the setting temp. is 68-73 °F.

3. Cooling only unit: When $T_{amb} \leq 71.6^{\circ}\text{F}$. it will run at Fan mode, the setting temp. is 77 °F.

4. When $73.4^{\circ}\text{F} \leq T_{indoor\ amb.} \leq 77^{\circ}\text{F}$, firstly enter into auto mode and run at auto fan speed, other modes will run at auto mode, will keep the previous running mode. (When entering into Dehumidifying mode, it will run at auto fan speed)

2. Display state of indoor indicators

(1) State of indoor display board

1. When the unit is powered on, all patterns will be displayed and then only power indicator is on. When the unit is turned on with a remote controller, the operating indicator is on and operation mode which is set currently is displayed.

2. In defrosting mode, "H1" is displayed on "Double 8".

3. Set temperature is displayed on "Double 8".

● Display of operation patterns and mode patterns

When the unit is powered on, all patterns will be displayed and the standby operation indicator will become red. When the unit is turned on through a remote controller, the operation indicator is light. At the same time, operating mode patterns (mode indicators include cooling, heating and dehumidification modes) set currently are displayed, and dynamic display patterns of wind speed are displayed. If the light button is switched off, all display will be turned off.

● Temperature display control mode of separated air conditioner

When user sets the remote controller at set temperature display, currently set temperature will be displayed.

Only when remote signals are converted from other display states into indoor ambient temperature display state, the remote controller will display indoor ambient temperature for 5 seconds and then return to set temperature display.

Only when remote signals are converted from other display states into outdoor ambient temperature display state, the remote controller will display outdoor ambient temperature for 5 seconds and then return to set temperature display.

If the controller is lack of outdoor display functions, as the signal is received, set temperature will be displayed.

When the unit is turned off, temperature display will be compulsively set at given temperature by the controller. When the unit is turned on, patterns as set by remote signals will be displayed.

If user does not set up temperature display state, given temperature will be displayed.

(2) Failure display of indoor unit

1. Requirements for failure display When multiple failures appear at the same time, failure protection codes shall be displayed alternatively.

Hardware failures shall be displayed immediately, referring to requirements in "Failure State Display Table";

Operation states shall be displayed immediately, referring to requirements in "Failure State Display Table";

Other failures shall be displayed 200s after the compressor stops, referring to requirements in "Failure State Display Table".(Note: in the case that the unit is switched off with the remote controller, or the compressor is switched on again, failure display waiting time (200s) shall be cleared.)

Frequency limitation and reduction states shall be displayed by means of remote calling.

2. Failure display control Indicator failure display shall be kept synchronous with Double 8 failure display, that is, during indicator blinking, failure code corresponding to such indicator shall be displayed on Double 8.

3. Method of remote calling of failure display

Entering the failure remote calling mode: push the light button four times within 3s to call out relevant failure protection code;Quit the failure remote calling mode: push the light button four times within 3s or call out failure display to enter it for 5 minutes and then quit.

3. Other control targets

(1) Up and down wind blow functions

When the unit is powered on, the up and down wind blow motor will turn a wind deflector anti-clockwise to Position 0 to shut down the air outlet. When the unit is switched on and wind blow function is not preset, under the heating mode, up and down wind blades will turn clockwise to position D; and under other modes, the up and down wind blades will turn clockwise to position L. If wind blow function is set at the same time as the unit is switched on, the wind blades will swing between positionL and D. The wind blades can be kept in seven states: position L, position A, position B, position C, position D, swing betweenposition L and D, stop at one position from L to D. When the unit is turned off, the wind deflector will be closed up to position 0. Wind blow action is effective only when wind blow commands are set and the indoor unit is running.

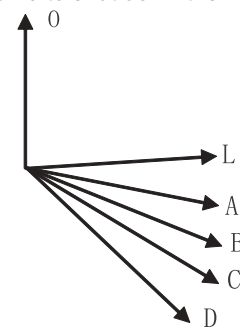

Note: When the wind blades are set at position L to B, position A to C, or position B to D through remote setting, the wind deflector will swing between position L and D. L—A—B—C—D.

(2) Buzzer

When the controller is powered on, signals from a remote controller are received, or the auto button is pushed, a buzzer will give out prompt tone.

(3) Auto button

When the button is pushed, the unit will operate in auto mode and the indoor fan will run in auto state. When the indoor fan is running, the wind blow motor will work. When the button is pushed again, the unit will be switched off. At the same time as the button is pushed, the whole unit will be powered on and enter into fast test mode; when the unit is powered on and detects for continuous 20s (such time shall not be fast tested) that the auto button is pushed, and if the unit is currently at fast test state, the unit will quit the fast test state.

(4)Sleep function

In this mode, the unit will select the suitable sleep curve to run according to the different setting temperature.

(5) Timing function

The main board integrates general timing and moment timing. Such two timing functions can be selected through a remote controller on which different functions are arranged.

1. General timing:

Timing start: timing start can be set when the unit is off. When preset time is reached, the controller will operate in a preset mode. Timing can be set at an interval of 0.5 hour in a scope of 0.5 - 24 hours.

Timing stop: timing stop can be set when the unit is on. When preset time is reached, the system will be turned off. Timing can be set at an interval of 0.5 hour in a scope of 0.5 - 24 hours.

2. Moment timing

Timing start: if timing start is set when the system is at operation state, the system will continue to operate; if timing start is set when the system is at stop, as the preset time is reached, the system will start to run in preset mode. Timing stop: if timing stop is set when the system is at stop state, the system will keep standby; if timing stop is set when the system is in operation, as the preset time is reached, the system will stop running.

Timing change:

When the system is in timing mode, start and stop can be set through the On/Off button on the remote controller; or timing time can be reset and the system will operate according to the latest setting. When the system is in operation and both timing start and stop are set, the system will stay at currently set operation state. When preset timing stop time is reached, the system will stop working. When the system is at stop state and both timing start and stop are set, the system will keep at stop state. When preset timingstart time is reached, the system will start operation. From then on, the system will operate in preset mode at a preset start time and stop at a preset stop time everyday. If timing stop time is set as the same as timing start time, a stop command will be executed.

(6) Dry and mildew proof function

Dry and mildew proof function can be set in cooling and dehumidification modes.

(7) Control of indoor fan

Indoor fan can be set at four levels, super-high, high, middle and low, with a remote controller. When one level is set, the fan will thus operate at such level. The fan can also be set at auto state.

(8) Power-failure memory function

What will be memorized includes modes, up and down wind blow, light, preset temperature, preset wind speed, general timing (no memory for moment timing), and Fahrenheit /Celsius degree. When the unit is powered on again after power failure, operation continues according to memorized content. If timing is not set by the last remote control command, the system will memorize the last remote control command and operate in the mode specified in the last remote control command. If timing is set by the last remote control command and power failure happens before the preset time, the system, as powered on again, will memorize the timing function set by the last remote control command. Timing will be re-counted from the time at which the system is powered again. If timing is set by the last remote control command and timing of start or stop is reached before power failure, the system, as powered on again, will memorize operation state before power failure and will not perform timing action. Moment timing is out the range of memory.

(9) Locked Protection of 内风机

When starting up the fans, if the motor has run at a lower speed continuously for a period, for preventing automatic protection of the motor, stop running, and display the locked operation; if the machine is running at present, the code of the locked fault---H6 of double-eight digital tubes will be displayed; if the machine is shut down at present, the information of the locked fault will not be displayed.

(10) Super Power Function

In cooling and heating modes (automatic, dehumidifying and air-supplying modes are without strong power), press the button of Super Power, the wind speed on the remote controller is displayed as super-high air flow, and the inner fans are also turned to super-high air flow;

(11) Health Function

When the inner fans are running, the remote controller is set at the Health function at this time (if there is no Health button on the remote controller, the Health On order is defaulted), then start the Health function device.

3. Fault Detection of Thermo-bulb

(1) Indoor Environment Thermo-bulb: Detect the fault of thermo-bulb at any time;

(2) Indoor Pipe Temperature Thermo-bulb: During the defrosting period, the fault of the thermo-bulb will be not detected, which shall be detected in 5 minutes after defrosting is completed; the fault of the thermo-bulb will be detected at other times;

(3) Protecting Treatments of Thermo-bulb

1. When the thermo-bulb is detected to be short-circuited continuously for 30 seconds: It is regarded that the temperature detected by the thermo-bulb is over-high (or unlimited), then the whole machine will exert corresponding safety stops according to the over-high temperature sensed by the thermo-bulb, and display corresponding temperature safety stops and faults of the thermo-bulb simultaneously.

2. When the thermo-bulb is detected in open circuit continuously for 30 seconds: stop the machine in protection, directly display corresponding faults of the thermo-bulb.

4. Forced Running Function of the Indoor Units

(1) Enter into Forced Running Control Within 5 minutes after power-up, press the Lights Off button on the remote controller continuously for three times within 3 seconds to enter into the fluorine collecting mode, and display Fo, send the fluorine-collecting mode for 25 minutes continuously, each load will be treated as cooling when starting the machine (set the air flow as High, set the temperature as 60.8 °F).

(2) Exit from the Forced Running Control After receiving any remote signal, or signal of keys, the fluorine-collecting mode will exit, and operate in accordance with the current orders set; or exit the fluorine-collecting mode after running for 25 minutes, and the machine will be shut down automatically.

Outdoor Part

1. Input Parameter Compensation and Calibration

(1) Check the ambient temperature compensation function

Indoor ambient temperature compensation function

a. In cooling mode, the indoor ambient temperature participating in computing control = $(T_{\text{indoor ambient temperature}} - T_{\text{cooling indoor ambient temperature compensation}})$

b. In heating mode, the indoor ambient temperature participating in computing control = $(T_{\text{indoor ambient temperature}} - T_{\text{heating indoor ambient temperature compensation}})$

(2) Check effective judgment controls of parameters

Effective judgment function of the outdoor exhaust temperature thermo-bulb When conditions a and b are satisfied, the outdoor exhaust temperature thermo-bulb is judged not to be connected into place, the mainboard of outer units will display failure of the outdoor exhaust temperature thermo-bulb (not connected into place), stop the machine for repairing, and resume the machine by remote controls of ON/OFF.

a. Judgment of exhaust detection temperature change: After the compressor starts up and runs for 10 minutes, if the compressor frequency $f \geq 40\text{Hz}$, and the rising value T_{exhaust} (T_{exhaust} (after start-up for 10 minutes) - T_{exhaust} (before start-up)) $< 35.6^\circ\text{F}$, the outdoor exhaust temperature thermo-bulb can be judged not to be connected into place (judging once when the power is on the first time).

b. Comparative judgment of exhaust detection temperature and condenser detection temperature ($T_{\text{pipe temperature}} = T_{\text{outdoor pipe temperature in cooling mode, } T_{\text{pipe temperature}} = T_{\text{indoor pipe temperature in heating mode}}$): After the compressor starts up and runs for 10 minutes, if the compressor frequency $f \geq 40\text{Hz}$, and $T_{\text{pipe temperature}} \geq (T_{\text{exhaust}} + 37.4^\circ\text{F})$, the outdoor exhaust temperature thermo-bulb can be judged not to be connected into place (judging once when power is on the first time).

2. Basic Functions

(1) Cooling Mode

1. Conditions and processes of cooling operation:

(1) If the compressor is shut down, and $[T_{\text{setup}} - (T_{\text{indoor ambient temperature}} - T_{\text{cooling indoor ambient temperature compensation}})] \leq 32.9^\circ\text{F}$, start up the machine for cooling, the cooling operation will start;

(2) During operations of cooling, if $32^\circ\text{F} \leq [T_{\text{setup}} - (T_{\text{indoor ambient temperature}} - T_{\text{cooling indoor ambient temperature compensation}})] < 35.6^\circ\text{F}$, the cooling operation will be still running;

(3) During operations of cooling, if $32^\circ\text{F} \leq [T_{\text{setup}} - (T_{\text{indoor ambient temperature}} - T_{\text{cooling indoor ambient temperature compensation}})]$, the cooling operation will stop after reaching the temperature point.

2. Temperature setting range

(1) If $T_{\text{outdoor ambient temperature}} \geq [T_{\text{low-temperature cooling temperature}}]$, the temperature can be set at: $60.8\sim 86^\circ\text{F}$ (Cooling at room temperature);

(2) If $T_{\text{outdoor ambient temperature}} < [T_{\text{low-temperature cooling temperature}}]$, the temperature can be set at: $77\sim 86^\circ\text{F}$ (Cooling at low temperature), that is, the minimum setting temperature for outer units judgment is 77°F .

(2)Drying Mode

1. Conditions and processes of drying operations: Same as the cooling mode;

2. The temperature setting range is: $60.8\sim 86^\circ\text{F}$;

(3) Air-supplying Mode

1. The compressor, outdoor fans and four-way valves are switched off;

2. The temperature setting range is: $60.8\sim 86^\circ\text{F}$.

(4) Heating Mode

1. Conditions and processes of heating operations: ($T_{\text{indoor ambient temperature}}$ is the actual detection temperature of indoor environment thermo-bulb, $T_{\text{heating indoor ambient temperature compensation}}$ is the indoor ambient temperature compensation during heating operations)

(1) If the compressor is shut down, and $[(T_{\text{indoor ambient temperature}} - T_{\text{heating indoor ambient temperature compensation}}) - T_{\text{setup}}] \leq 32.9^\circ\text{F}$, start the machine to enter into heating operations for heating;

(2) During operations of heating, if $32^\circ\text{F} \leq [(T_{\text{indoor ambient temperature}} - T_{\text{heating indoor ambient temperature compensation}}) - T_{\text{setup}}] < 35.6^\circ\text{F}$, the heating operation will be still running;

(3) During operations of heating, if $35.6^\circ\text{F} \leq [(T_{\text{indoor ambient temperature}} - T_{\text{heating indoor ambient temperature compensation}}) - T_{\text{setup}}]$, the heating operation will stop after reaching the temperature point.

2. The temperature setting range in this mode is: $60.8\sim 86^\circ\text{F}$.

3. Special Functions

Defrosting Control

Conditions for starting defrosting

After the time for defrosting is judged to be satisfied, if the temperature for defrosting is satisfied after detections for continuous 3minutes, the defrosting operation will start.

Conditions of finishing defrosting

The defrosting operation can exit when any of the conditions below is satisfied

$T_{\text{outdoor pipe temperature}} \geq (T_{\text{outdoor ambient temperature}} - [T_{\text{temperature 1 of finishing defrosting}}])$;

The continuous running time of defrosting reaches $[t_{\text{max. defrosting time}}]$.

4. Control Logic

(1) Compressor Control

Start the compressor after starting cooling, heating, dehumidifying operations, and the outer fans start for 5s; When the machine is shutdown, in safety stops and when switching to air-supplying mode, the compressor will stop immediately.

In all modes: once the compressor starts up, it will not be allowed to stop until having run for the [t_{min. compressor running time}] (Note: including cases of shutdown when the temperature point is reached; except the cases requiring stopping the compressor such as fault protection, remote shutdown, mode switching etc.);

In all modes: once the compressor stops, it will be allowed be restart after 3-minute delay (Note: The indoor units have a function of power memory, the machine can be restarted after remote shutdown and powering up again without delay).

1. Cooling mode

Start the machine to enter into cooling operation for cooling, the compressor is switched on.

2. Drying mode

Same as the cooling mode.

3. Air-supplying mode

The compressor is switched off.

4. Heating mode

(1) Start the machine to enter into heating operation for heating, the compressor is switched on.

(2) Defrosting:

a. Defrosting starts: the compressor is shut down, and restarts it after 55-second delay.

b. Defrosting ends: the compressor stops, then starts it after 55-second delay.

(2) Outer Fans Control

Notes:

Only the outer fans run for at least 80s in each air flow speed can the air flow be switched; After the outer fans run compulsively in high speed for 80s when the machine starts up, control the air flow according to the logic. After remote shutdown, safety stops, and when the machine stops after reaching the temperature point, as well as after the compressor stops, extend 1 minute, the outer fans will stop (During the period in the 1 minute, the air flow of outer fans can be changed according to the outdoor ambient temperature changes); When running with force, the outdoor fans shall run in the highest air flow.

(3) 4-way valve control

1. The 4-way valve control under the modes of Cooling, dehumidification and supplying air: closing;

2. The status of 4-way valve control under the heating mode: getting power;

(1) 4-way valve power control under heating mode a. Starts the machine under heating mode, the 4-way valve will get power immediately.

(2) 4-way valve power turn-off control under heating mode a. When you should turn off the power or switch to other mode under heating mode, the power of 4-way valve will be cut after 2 minutes of the compressor stopped. b. When all kinds of protection stops, the power of 4-way valve will be cut after delaying 4 minutes.

(3) Defrosting control under heating mode: a. Defrosting begins: The power of 4-way valve will be cut after 50s of entering into the defrosting compressor.

b. Defrosting stops: The 4-way valve will get power after 50s of exiting the defrosting compressor.

(4) Evaporator frozen-preventing protection function

At the mode of Cooling, dehumidifying:

Evaporator frozen-preventing protection function is allowed to begin after 6 min of starting the compressor.

1. Starting estimation: After the compressor stopped working for 180s, if $T_{\text{inner pipe}} > [T_{\text{frozen-preventing frequency-limited temperature}}]$

(the temperature of hysteresis is 35.6°F), the machine is only allowed to start for operating, otherwise it should not be started, and should be stopped to treat according to the frozen-preventing protection: Clear the trouble under the mode of power turn-off / heating, and the protection times are not counted.

2. Frequency limited

$[T_{\text{frozen-preventing normal speed frequency-reducing temperature}}] \leq T_{\text{inner pipe}} < [T_{\text{frozen-preventing frequency-limited temperature}}]$, you should limit the frequency raising of compressor.

3. Reducing frequency at normal speed

If $[T_{\text{frozen-preventing high speed frequency-reducing temperature}}] \leq T_{\text{inner pipe}} < [T_{\text{frozen-preventing normal speed frequency-reducing temperature}}]$, you should adjust the compressor frequency by reducing 8Hz/90s till the lower limit;

4. Reducing frequency at high speed

If $[T_{\text{frozen-preventing power turn-off temperature}}] \leq T_{\text{inner pipe}} < [T_{\text{frozen-preventing high speed frequency-reducing temperature}}]$ you should adjust the compressor frequency by reducing 30Hz/90s till the lower limit;

5. Power turn-off

If the $T_{\text{inner pipe}} < [T_{\text{frozen-preventing power turn-off temperature}}]$, then frozen-preventing protect to stop the machine; If

$[T_{\text{frozen-preventing frequency-limited temperature}}] < T_{\text{inner pipe}}$, and the compressor has stopped working for 3 minutes, the whole machine should be allowed to operate.

6. If the frozen-preventing protection power turn-off continuously occurs for six times, it should not be resumed automatically, and you should press the ON/OFF button to resume if the fault keeps on. During the process of running, if the running time of compressor exceeds the [t_{evaporator frozen-preventing protection times zero clearing time}], the times of frozen-preventing power turn-off should be cleared to recount. The mode of stopping the machine or transferring to supply air will clear the trouble times immediately (if the trouble can not be resumed, mode transferring will not clear it).

(5) Overload protection function

Overload protection function at the mode of Cooling and dehumidifying

1. Starting estimation: After the compressor stopped working for 180s, if $T_{\text{outer pipe}} < [T_{\text{Cooling overload frequency-limited temperature}}]$ (the temperature of hysteresis is 35.6 °F), the machine is allowed to start, otherwise it should not be started, and should be stopped to treat according to the overload protection: Clear the trouble at the mode of power turn-off / heating, and the protection times are not counted.

2. Frequency limited If $[T_{\text{Cooling overload frequency-limited temperature}} \leq T_{\text{outer pipe}} < [T_{\text{Cooling overload frequency reducing temperature at normal speed}}]$, you should limit the frequency raising of compressor.

3. Reducing frequency at normal speed and power turn-off:

If $[T_{\text{Cooling overload frequency reducing temperature at high speed}}] \leq T_{\text{outer pipe}} < [T_{\text{Cooling overload power turn-off temperature}}]$, you should adjust the compressor frequency by reducing 8Hz/90s till the lower limit; After it was running 90s at the lower limit, if $[T_{\text{Cooling overload frequency reducing temperature at normal speed}}] \leq T_{\text{outer pipe}}$, then Cooling overload protects machine stopping;

4. Reducing frequency at high speed and stop machine

If $[T_{\text{Cooling overload frequency reducing temperature at high speed}}] \leq T_{\text{outer pipe}} < [T_{\text{Cooling overload power turn-off temperature}}]$ you should adjust the compressor frequency by reducing 30Hz/90s till the lower limit; After it was running 90s at the lower limit, if $[T_{\text{Cooling overload frequency reducing temperature at normal speed}}] \leq T_{\text{outer pipe}}$, then Cooling overload protects machine stopping;

5. Power turn-off

If the $[T_{\text{Cooling overload power turn-off temperature}}] \leq T_{\text{outer pipe}}$, then Cooling overload protects machine stopping; If $T_{\text{outer pipe}} < [T_{\text{Cooling overload frequency-limited temperature}}]$ and the compressor has been stopped working for 3 minutes, the machine should be allowed to operate.

6. If the Cooling overload protection power turn-off continuously occurs for six times, it should not be resumed automatically, and you should press the ON/OFF button to resume if the fault keeps on. During the process of running, if the running time of compressor exceeds the [t_{overload protection times zero clearing time}], the times of overload protection power turn-off should be cleared to recount. The mode of stopping the machine or transferring to supply air will clear the trouble times immediately (if the trouble can not be resumed, transferring mode will not clear it).

Overload protection function at the mode of heating

Starting estimation

After the compressor stopped working for 180s, if $T_{\text{inner pipe}} < [T_{\text{heating overload frequency-limited temperature}}]$ (the temperature of hysteresis is 35.6 °F), the machine is allowed to start, otherwise it should not be started, and should be stopped to treat according to the overload protection: Clear the trouble at the mode of power turn-off / heating, and the protection times are not counted.

1. Frequency limited

If $[T_{\text{heating overload frequency-limited temperature}}] \leq T_{\text{inner pipe}} < [T_{\text{heating overload frequency reducing temperature at normal speed}}]$, you should limit the frequency raising of compressor.

2. Reducing frequency at normal speed and stopping machine: If $[T_{\text{heating overload frequency reducing temperature at normal speed}}] \leq T_{\text{inner pipe}} < [T_{\text{heating overload frequency reducing temperature at high speed}}]$, you should adjust the compressor frequency by reducing 8Hz/90s till the lower limit; After it was running 90s at the lower limit, if $[T_{\text{heating overload frequency reducing temperature at normal speed}}] \leq T_{\text{inner pipe}}$, then overload protects machine stopping;

3. Reducing frequency at high speed and power turn-off: If $[T_{\text{heating overload frequency reducing temperature at high speed}}] \leq T_{\text{inner pipe}} < [T_{\text{heating overload power turn-off temperature}}]$ you should adjust the compressor frequency by reducing 30Hz/90s till the lower limit; After it was running 90s at the lower limit, if $[T_{\text{heating overload frequency reducing temperature at normal speed}}] \leq T_{\text{outer pipe}}$, then Cooling overload protects machine stopping;

4. Power turn-off: If the $[T_{\text{heating overload power turn-off temperature}}] \leq T_{\text{inner pipe}}$, then overload protects machine stopping; If $T_{\text{inner pipe}} < [T_{\text{heating overload frequency-limited temperature}}]$ and the compressor has been stopped working for 3 minutes, the machine should be allowed to operate.

5. If the overload protection power turn-off continuously occurs for six times, it should not be resumed automatically, and you should press the ON/OFF button to resume if the fault keeps on. During the process of running, if the running time of compressor exceeds the [t_{overload protection times zero clearing time}], the times of overload protection power turn-off should be cleared to recount. The mode of stopping the machine or transferring to supply air will clear the trouble times immediately (if the trouble can not be resumed, transferring mode will not clear it).

Protective function for discharge temperature of compressor

1. Starting estimation:

After the compressor stopped working for 180s, if $T_{\text{Discharge}} < [T_{\text{Discharge limited temperature}}]$ (the temperature of hysteresis is 35.6°F), the machine is allowed to start, otherwise it should not be started, and should be stopped to treat according to the discharge temperature: The machine should be stopped or transferred to supply air, the trouble should be cleared immediately, and the protection times are not counted.

2. Frequency limited

If $[T_{\text{Limited frequency temperature during discharging}}] \leq T_{\text{Discharge}} < [T_{\text{frequency reducing temperature at normal speed during discharging}}]$, you should limit the frequency raising of compressor.

3. Reducing frequency at normal speed and stopping machine: If $[T_{\text{frequency reducing temperature at normal speed during discharging}}] \leq T_{\text{Discharge}} < [T_{\text{frequency reducing temperature at high speed during discharging}}]$ you should adjust the compressor frequency by reducing 8Hz/90s till the lower limit; After it was running 90s at the lower limit, if $[T_{\text{frequency reducing temperature at normal speed during discharging}}] \leq T_{\text{Discharge}}$, you should discharge to protect machine stopping;
4. Reducing frequency at high speed and power turn-off: If $[T_{\text{frequency reducing temperature at high speed during discharging}}] \leq T_{\text{Discharge}} < [T_{\text{Stop temperature during discharging}}]$ you should adjust the compressor frequency by reducing 30Hz/90s till the lower limit; After it was running 90s at the lower limit, if $[T_{\text{frequency reducing temperature at normal speed during discharging}}] \leq T_{\text{Discharge}}$, you should discharge to protect machine stopping;
5. Power turn-off: If the $[T_{\text{Power turn-off temperature during discharging}}] \leq T_{\text{Discharge}}$, you should discharge to protect machine stopping; If $T_{\text{Discharge}} < [T_{\text{Limited frequency temperature during discharging}}]$ and the compressor has been stopped for 3 minutes, the machine should be allowed to operate.
6. If the discharging temperature protection of compressor continuously occurs for six times, it should not be resumed automatically, and you should press the ON/OFF button to resume. During the process of running, if the running time of compressor exceeds the $[t_{\text{Protection times clearing of discharge}}]$, the discharge protection is cleared to recount. Stopped or transferred to supply air mode will clear the trouble times immediately (if the trouble can not be resumed, mode transferring also will not clear it).
7. Frequency limited
If $[I_{\text{Limited frequency when overcurrent}}] \leq I_{\text{AC Electric current}} < [I_{\text{frequency reducing when overcurrent}}]$, you should limit the frequency raising of compressor.
8. Reducing frequency:
If $[I_{\text{Frequency reducing when overcurrent}}] \leq I_{\text{AC Electric current}} < [I_{\text{Power turn-off when overcurrent}}]$, you should reduce the compressor frequency till the lower limit or exit the frequency reducing condition;
9. Power turn-off: If $[I_{\text{Power turn-off machine when overcurrent}}] \leq I_{\text{AC Electric current}}$, you should carry out the overcurrent stopping protection; If $I_{\text{AC Electric current}} < [I_{\text{Limited frequency when overcurrent}}]$ and the compressor has been stopped for 3 minutes, the machine should be allowed to operate.
10. If the overcurrent protection continuously occurs for six times, it should not be resumed automatically, and you should press the ON/OFF button to resume. During the process of running, if the running time of compressor exceeds the $[t_{\text{Protection times clearing of overcurrent}}]$, the discharge protection is cleared to recount.

(6) Voltage sag protection

After start the compressor, if the time of DC link Voltage sag $[U_{\text{Sagging protection voltage}}]$ is measured to be less than $[t_{\text{Voltage sag protection time}}]$, the machine should be stop at once, hand on the voltage sag trouble, reboot automatically after 30 minutes.

(7) Communication fault

When you have not received any correct signal from the inner machine in three minutes, the machine will stop for communication fault. When you have not received any correct signal from driver IC (aim to the controller for the separating of main control IC and driver IC), and the machine will stop for communication fault. If the communication is resumed, the machine will be allowed to operate.

(8) Module protection

Testing the module protective signal immediately after started, once the module protective signal is measured, stop the machine with module protection immediately. If the module protection is resumed, the machine will be allowed to operate.

If the module protection continuously occurs for three times, it should not be resumed automatically, and you should press the ON/OFF button to resume. If the running time of compressor exceeds the $[t_{\text{Protection times clearing of module}}]$, the module protection is cleared to recount.

(9) Module overheating protection

1. Starting estimation:

After the compressor stopped working for 180s, if $T_{\text{Module}} < [T_{\text{Module frequency limited temperature}}]$ (the temperature of hysteresis is 35.6°F), the machine is allowed to start, otherwise it should not be started, and should be stopped to treat according to the module overheating protection: The machine should be stopped or transferred to supply air, the trouble should be cleared immediately, and the protection times are not counted.

2. Frequency limited

If $[T_{\text{Limited frequency temperature of module}}] \leq T_{\text{Module}} < [T_{\text{frequency reducing temperature at normal speed of module}}]$, you should limit the frequency raising of compressor.

3. Reducing frequency at normal speed and power turn-off: If $[T_{\text{frequency reducing temperature at normal speed of module}}] \leq T_{\text{Module}} < [T_{\text{frequency reducing temperature at high speed of module}}]$, you should adjust the compressor frequency by reducing 8Hz/90s till the lower limit; After it was running 90s at the lower limit, if $[T_{\text{frequency reducing temperature at normal speed of module}}] < T_{\text{Module}}$, you should stop the machine for module overheating protection;

2. Frequency limited If $[T_{\text{Limited frequency temperature of module}}] \leq T_{\text{Module}} < [T_{\text{frequency reducing temperature at normal speed of module}}]$, you should limit the frequency raising of compressor.

3. Reducing frequency at normal speed and power turn-off
If $[T_{\text{frequency reducing temperature at normal speed of module}}] \leq T_{\text{Module}} < [T_{\text{frequency reducing temperature at high speed of module}}]$, you should adjust the compressor frequency by reducing 8Hz/90s till the lower limit; After it was running 90s at the lower limit, if $[T_{\text{frequency reducing temperature at normal speed of module}}] \leq T_{\text{Module}}$, you should stop the machine for module overheating protection;

4. Reducing frequency at high speed and power turn-off

If $[T_{\text{frequency reducing temperature at high speed of module}}] \leq T_{\text{Module}} < [T_{\text{Power turn-off temperature of module}}]$ you should adjust the compressor frequency by reducing 30Hz/90s till the lower limit; After it was running 90s at the lower limit, if $[T_{\text{frequency reducing temperature at normal speed of module}}] \leq T_{\text{Module}}$, you should stop the machine for module overheating protection;

4. Reducing frequency at high speed and power turn-off

If $[T_{\text{frequency reducing temperature at high speed of module}}] \leq T_{\text{Module}} < [T_{\text{Power turn-off temperature of module}}]$ you should adjust the compressor frequency by reducing 30Hz/90s till the lower limit; After it was running 90s at the lower limit, if $[T_{\text{frequency reducing temperature at normal speed of module}}] \leq T_{\text{Module}}$, you should stop the machine for module overheating protection;

5. Power turn-off

If the $[T_{\text{Power turn-off temperature of module}}] \leq T_{\text{Module}}$, you should stop the machine for module overheating protection; If $T_{\text{Module}} < [T_{\text{Limited frequency temperature of module}}]$ and the compressor has been stopped for 3 minutes, the machine should be allowed to operate.

6. If protection continuously occurs for six times, it should not be resumed automatically, and you should press the ON/OFF button to resume. During the process of running, if the running time of compressor exceeds the $[t_{\text{Protection times clearing of module}}]$, the discharge protection is cleared to recount. Stopped or transferred to supply air mode will clear the trouble times immediately (if the trouble can not be resumed, mode transferring also will not clear it).

(10) Compressor overloads protection

If you measure the compressor overload switch action in 3s, the compressor should be stopped for overloading. The machine should be allowed to operate after overload protection was measured to resume.

If the overloading protection continuously occurs for three times, it should not be resumed automatically, and you should press the ON/OFF button to resume. The protection times of compressor is allowed to clear after the compressor run

$[t_{\text{Protection times clearing of compressor overloading}}]$ 30 minutes.

(11) Phase current overcurrent protection of compressor

During the running process of compressor, you could measure the phase current of the compressor, and control it according to the following steps:

1. Frequency limited

If $[I_{\text{Limited frequency phase current}}] \leq I_{\text{Phase current}} < [I_{\text{Frequency reducing phase current}}]$, you should limit the frequency raising of compressor.

2. Reducing Frequency

If $[I_{\text{Frequency Reducing Phase Current}}] \leq I_{\text{Phase Current}} < [I_{\text{Power TurnOff Phase Current}}]$, the compressor shall continue to reduce frequency till the lowest frequency limit or out of the condition of reducing frequency;

3. Power turn-off If $I_{\text{Phase Current}} \geq [I_{\text{Power TurnOff Phase Current}}]$, the compressor phase current shall stop working for overcurrent protection; if $I_{\text{Phase Current}} \leq [I_{\text{Frequency Reducing Phase Current}}]$, and the compressor have stopped working for 3 min, the machine shall be allowed to operate;

4. If the overcurrent protection of compressor phase current continuously occurs for six times, it should not be resumed automatically, and you should press the ON/OFF button to resume. During the process of running, if the running time of compressor exceeds the $[t_{\text{Clearing Time of Compressor Phase Current Times}}]$, the overcurrent protection is cleared to recount.

(12) Starting-up Failure Protection for Compressor

Stop the compressor after its startingup fails, restart it after 20s if the fault doesn't shows, and if they are all failing for the successive start 3 times, it shall be reported as Startingup Failure, and then restart up it after 3 min. When it still not be able to operate through carry out the above process for 5 times, it is available if press ON/OFF. And the compressor should be cleared the times after it run 2 min.

(13) Out-of-Step Protection for Compressor

The outofstep protection signal should be detected immediately after startingup compressor, and once find the out-of-step protection signal, the outofstep protection shall be stopped; if it can run for lasting power turn off 3 min, the machine shall be allowed to operate. If it still can't run automatically when the turn-off-times protection for compressor happens to stop working for 6 times in succession, it needs to press ON/OFF to operate. And if the running time is more than 10 min, the power turn-off-times for out of step protection shall be cleared and recounted.

(14) Voltage Abnormity Protection for DC Bus To detect voltage abnormity protection for dc bus after completing the precharge:

1. Over-High Voltage Protection for DC Bus

If it found the DC bus voltage $U_{\text{DC}} > [U_{\text{DC Jiekuangchun Protection}}]$, turn off PFC and stop the compressor at once, and it shall show the DC over-high voltage failure; it should clear out the failure when the voltage dropped to $U_{\text{DC}} < [U_{\text{DC Jiekuangchun Recovery}}]$ and the compressor stopped for 3 min.

2. Over-Low Voltage Protection for DC Bus

If it found the DC bus voltage $U_{\text{DC}} < [U_{\text{DC Wantuochun Protection}}]$, turn off PFC and stop the compressor at once, and it shall show the DC over-low voltage; and it should clear out the failure when the voltage raised to $U_{\text{DC}} > [U_{\text{DC Wantuochun Recovery}}]$ and the compressor stopped for 3 min.

3. To detect voltage abnormity protect for DC bus when getting electricity

If it found the DC bus voltage $U_{\text{DC}} > [U_{\text{DC—Over-High Voltage}}]$, turn off the relay at once, and shows voltage abnormity failure for DC Bus. And the failure can't recover except to break off and get the electricity.

(15) Abnormity Protection for Four-way Valve

Under the model of heating operation in good condition: the compressor is detected $T_{\text{Inner Tube}} < (T_{\text{Inner Ring}} - [T_{\text{Abnormity Temperature Difference For Four-Way Valve Reversion}}])$, during the running, it should be regarded as four-way valve reversion abnormity. And then it can run if stop the reversion abnormity protection for four-way valve 3 min; and if it still can't run when the reversion abnormity protection for four-way valve happens to stop working for 3 times in succession, it is available if presses ON/OFF.

Attention: the protection shall be shielded during the testing mode and defrosting process, and it shall be cleared out the failure and its times immediately when turning off or delivering wind / cooling / dehumidifying mode conversed (the inverted mode don't clear out the failure when it can't recover to operate).

(16) PFC Protection

1. After start up the PFC, it should detect the protection signal of PFC immediately; under the condition of PFC protection, it should turn off the PFC and compressor at one time;
2. It shows the failure is cleared out if PFC Protection stopped working 3 min and recovers to run automatically;
3. If it still can't run when it occurs PFC protection for 3 times in succession, it is available if presses ON/OFF; and clear the PFC Protection times when start up PFC for 10min.

(17) Failure Detection for Sensor

1. Outdoor Ambient Sensor: detect the failure of sensor at all times.
2. Outdoor Tube Sensor: You should not detect the failure of outdoor tube sensor within 10 minutes heating operation compressor except the defrosting, and you could detect it at other time.
3. Outdoor Exhaust Sensor:
 - (a) The compressor only detect the sensor failure after it start up 3 min in normal mode;
 - (b) It should detect the exhaust sensor failure immediately in the testing mode.
4. Module Temperature Sensor:
 - (a) Short-Circuit Detection: the compressor should be detected immediately when the module temperature sensor occurs short-circuits;
 - (b) Open-Circuit Detection: the compressor should be detected on open-circuit when it runs 3min (it needn't 30s avoiding the module over-heated).
 - (c) Detect the sensor failure at all times in the testing mode.
5. Disposal for Sensor Protection
 - (1) When the short-circuit of sensor is detected within 30s, It is regarded as the temperature of sensor over-high (or infinitely high), and now according to the over-high sensor, the machine should carry out the corresponding protection to stop working, and show the corresponding temperature shutdown protection and sensor failure at the same time (for example: the compressor stops immediately when the outdoor tube sensor short-circuit, and the machine shall show the overload protection and outdoor tube sensor failure).
 - (2) When the open-circuit of sensor is detected within 30s, The protection shall be stopped and it shall show the corresponding sensor failure.

7. Installation Manual

7.1 Notices for Installation

! Caution

- 1.The unit should be installed only by authorized service center according to local or government regulations and in compliance with this manual.
- 2.Before installing, please contact with local authorized maintenance center. If the unit is not installed by the authorized service center, the malfunction may not be solved due to inconvenient contact between the user and the service personnel.
- 3.When removing the unit to the other place, please firstly contact with the local authorized service center.
- 4.Warning: Before obtaining access to terminals, all supply circuits must be disconnected.
- 5.For appliances with type Y attachment, the instructions shall contain the substance of the following. If the supply cord is damaged, it must be replaced by the manufacturer, its service agent or similarly qualified persons in order to avoid a hazard.
- 6.The appliance must be positioned so that the plug is accessible.
- 7.The temperature of refrigerant line will be high; please keep the interconnection cable away from the copper tube.
- 8.The instructions shall state the substance of the following:

This appliance is not intended for use by persons(including children)with reduced physical, sensory or mental capabilities, or lack of experience and knowledge, unless they have been given supervision or instruction concerning use of the appliance by a person responsible for their safety.

Children should be supervised to ensure that they do not play with the appliance.

7.1.1 Installation Site Instructions

Proper installation site is vital for correct and efficient operation of the unit. Avoid the following sites where:

- strong heat sources, vapours, flammable gas or volatile liquids are emitted.
- high-frequency electro-magnetic waves are generated by radio equipment, welders and medical equipment.
- salt-laden air prevails (such as close to coastal areas).
- the air is contaminated with industrial vapours and oils.
- the air contains sulphures gas such as in hot spring zones.
- corrosion or poor air quality exists.

7.1.2 Installation Site of Indoor Unit

- 1.The air inlet and outlet should be away from the obstructions. Ensure the air can be blown through the whole room.
- 2.Select a site where the condensate can be easily drained out, and where it is easily connected to outdoor unit.
- 3.Select a place where it is out of reach of children.
- 4.Select a place where the wall is strong enough to withstand the full weight and vibration of the unit.
- 5.Be sure to leave enough space to allow access for routine maintenance. The installation site should be 66in. or more above the floor.
- 6.Select a place about 3.3ft. or more away from TV set or any other electric appliance.
- 7.Select a place where the filter can be easily taken out.
- 8.Make sure that the indoor unit is installed in accordance with installation dimension instructions.
- 9.Do not use the unit in the laundry or by swimming pool etc.

7.1.3 Installation Site of Outdoor Unit

- 1.Select a site where noise and outflow air emitted by the unit will not annoy neighbors.
- 2.S elect a site where there is sufficient ventilation.
- 3.Select a site where there is no obstruction blocking the inlet and outlet.
- 4.The site should be able to withstand the full weight and vibration.
- 5.Select a dry place, but do not expose the unit to direct sunlight or strong wind.
- 6.Make sure that the outdoor unit is installed in accordance with the installation instructions,and is convenient for maintenance and repair.
- 7.The height difference between indoor and outdoor units is within A ft., and the length of the connecting tubing does not exceed B ft..

Model	A	B
09K	33	50
12K	33	66
18K	33	82
24K	33	82

8. Select a place where it is out of reach of children.
9. Select a place where the unit does not have negative impact on pedestrians or on the city.

7.1.4 Safety Precautions for Electric Appliances

1. A dedicated power supply circuit should be used in accordance with local electrical safety regulations.
2. Don't drag the power cord with excessive force.
3. The unit should be reliably earthed and connected to an exclusive earth device by the professionals.
4. The air switch must have the functions of magnetic tripping and heat tripping to prevent short circuit and overload.
5. The minimum distance between the unit and combustive surface is 59.1in..
6. The appliance shall be installed in accordance with national wiring regulations.
7. An all-pole disconnection switch with a contact separation of at least 0.1in. in all poles should be connected in fixed wiring.

Note:

- **Make sure the live wire, neutral wire and earth wire in the family power socket are properly connected. There should be reliable circuit in the diagram.**
- **Inadequate or incorrect electrical connections may cause electric shock or fire.**

7.1.5 Earthing Requirements

1. Air conditioner is type I electric appliance. Please ensure that the unit is reliably earthed.
2. The yellow-green wire in air conditioner is the earthing wire which can not be used for other purposes. Improper earthing may cause electric shock.
3. The earth resistance should accord to the national criterion.
4. The power must have reliable earthing terminal. Please do not connect the earthing wire with the following:
 - ① Water pipe
 - ② Gas pipe
 - ③ Contamination pipe
 - ④ Other place that professional personnel consider is unreliable
5. The model and rated values of fuses should accord with the silk print on fuse cover or related PCB.

7.2 Installation Drawing

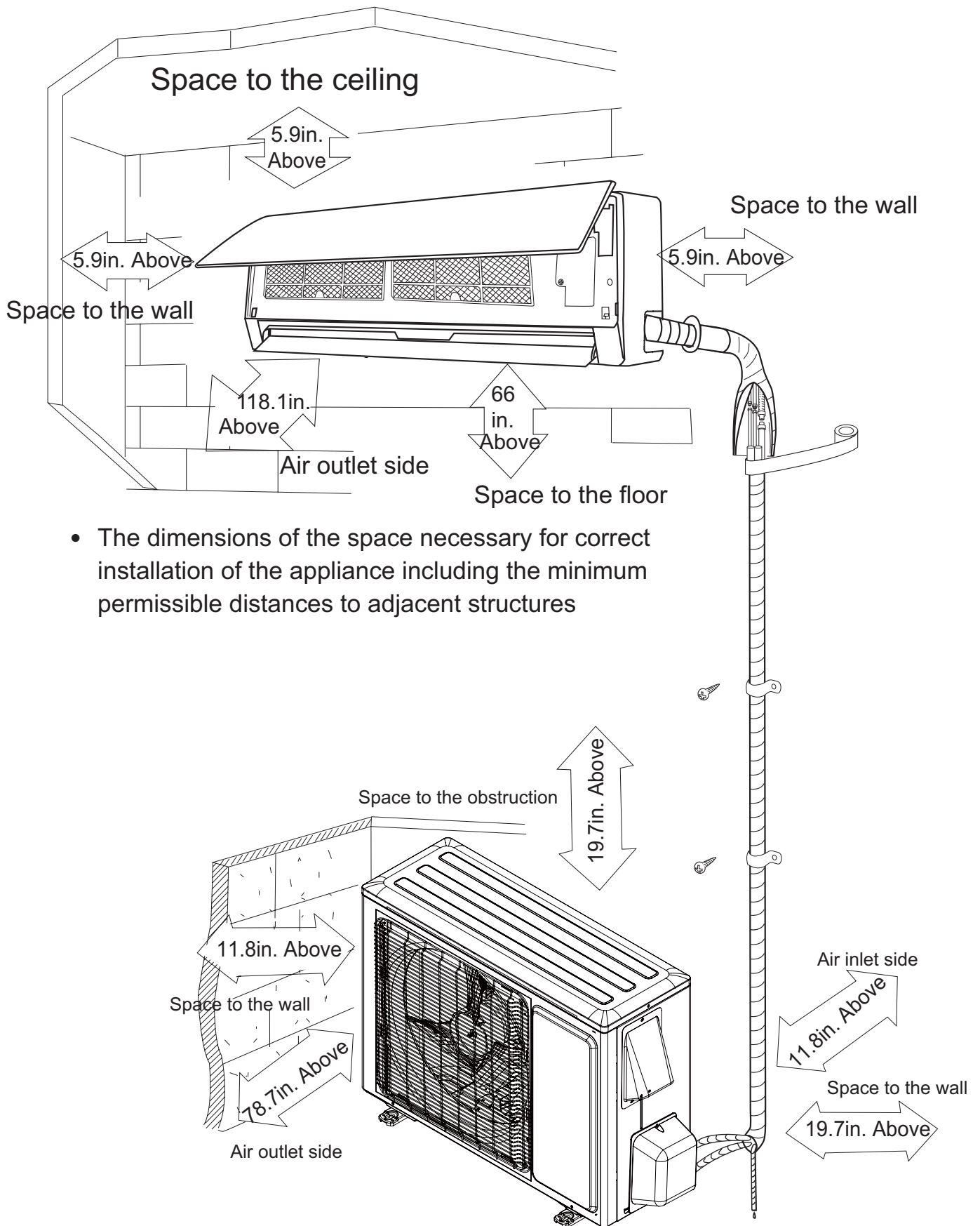

- The dimensions of the space necessary for correct installation of the appliance including the minimum permissible distances to adjacent structures

7.3 Install Indoor Unit

7.3.1 Installation of Mounting Plate

1. Mounting plate should be installed horizontally. As the water tray's outlet for the indoor unit is two-way type, during installation, the indoor unit should slightly slant to water tray's outlet for smooth drainage of condensate.
2. Fix the mounting plate on the wall with screws.
3. Be sure that the mounting plate has been fixed firmly enough to withstand about 132lb. . Meanwhile, the weight should be evenly shared by each screw. (The hole for 24K is $\Phi 2.8$ in.)

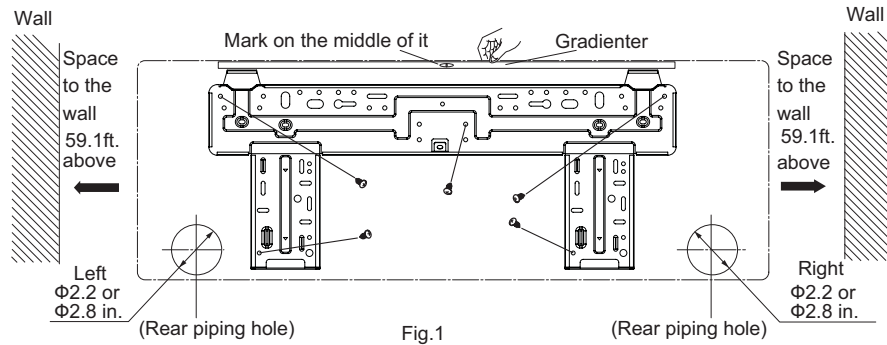

7.3.2 Drill Piping Hole

1. Slant the piping hole ($\Phi 2.2$ in.) on the wall slightly downward to the outdoor side. (The hole for 24K is $\Phi 2.8$ in.)
2. Insert the piping-hole sleeve into the hole to prevent the connection piping and wiring from being damaged when passing through the hole.

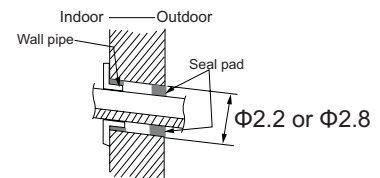

7.3.3 Installation of Drain Hose

1. Connect the drain hose to the outlet pipe of the indoor unit. Bind the joint with rubber belt.
2. Put the drain hose into insulating tube.

3. Wrap the insulating tube with wide rubber belt to prevent the shift of insulating tube. Slant the drain hose downward slightly for smooth drainage of condensate.

Note: The insulating tube should be connected reliably with the sleeve outside the outlet pipe. The drain hose should be slanted downward slightly, without distortion, bulge or fluctuation. Do not put the outlet in the water.

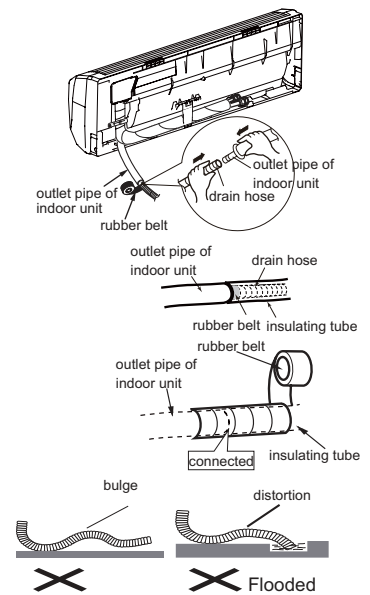

7.3.4 Connecting Indoor and Outdoor Electric Wires

1. Open the front panel.
2. Remove the wiring cover. Connect and fix the power connection cord to the terminal board as shown in Fig.2.
3. Make the power connection cord pass through the hole at the back of indoor unit.
4. Reinstall the cord anchorage and wiring cover.
5. Reinstall the front panel.

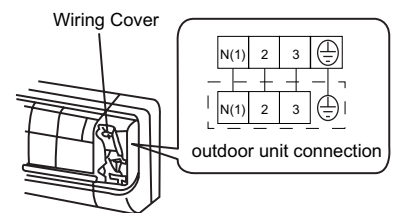

Fig.2

NOTE:

All wires between indoor and outdoor units must be connected by the qualified electric contractor.

- Electric wires must be connected correctly. Improper connection may cause malfunction.
- Tighten the terminal screws securely.
- After tightening the screws, pull the wire slightly to confirm whether it's firm or not.
- Make sure that the electric connections are earthed properly to prevent electric shock.
- Make sure that all wiring connections are secure and the cover plates are reinstalled properly. Poor installation may cause fire or electric shock.

7.3.5 Installation of Indoor Unit

•The piping can be output from right, right rear, left or left rear.

1. When routing the piping and wiring from the left or right side of indoor unit, cut off the tailings from the chassis when necessary (As shown in Fig.3)

- (1) Cut off tailing 1 when routing the wiring only;
- (2) Cut off tailing 1 and tailing 2 when routing both the wiring and piping.

2. Take out the piping from body case; wrap the piping, power cords, drain hose with the tape and then make them pass through the piping hole. (As shown in Fig.4)

3. Hang the mounting slots of the indoor unit on the upper hooks of the mounting plate and check if it is firm enough. (As shown in Fig.5)

4. The installation site should be 250cm or more above the floor.

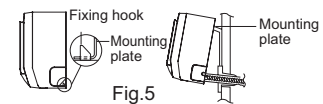
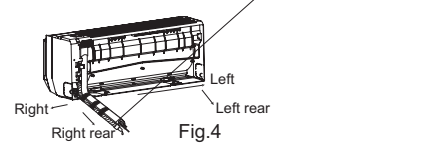
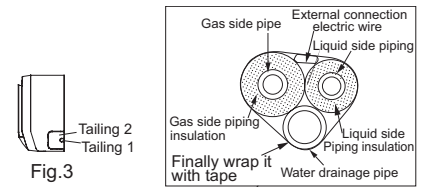

7.3.6 Installation of Connection Pipe

1. Align the center of the pipe flare with the related valve.
2. Screw in the flare nut by hand and then tighten the nut with spanner and torque wrench by referring to the following:

Hex nut diameter	Tightening torque(N·m)
Φ6	30 ~ 40
Φ9.52	15 ~ 20
Φ12	45 ~ 55
Φ16	60 ~ 65
Φ19	70 ~ 75

NOTE: Connect the connection pipe to indoor unit at first and then to outdoor unit. Handle piping bending with care. Do not damage the connection pipe. Ensure that the joint nut is tightened firmly, otherwise, it may cause leakage.

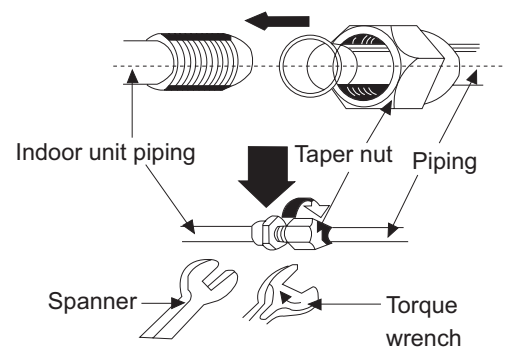

7.4 Install Outdoor Unit

7.4.1 Electric Wiring

1. Remove the cable-cross board of outdoor right side plate.
2. Put the power connection wire and power cord through the wire hole.
3. Take off the wire clamp. Connect the power connection wire and power cord to the terminal and then fix them. Wiring should be coherent with the indoor unit.
4. Fix the power connection wire and power cord with wire clamp.
5. Ensure if the wires have been fixed well.
6. Install the cable-cross board.

NOTE:

- Incorrect wiring may cause malfunction of spare part.
 - After the wire has been fixed, ensure there is free space between the connection and fixing places on the lead wire.
- Schematic diagram being reference only, please refer to real product for authentic information.

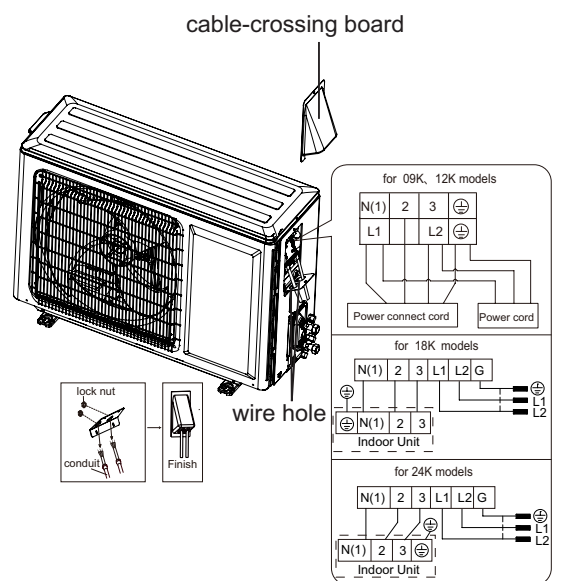

7.4.2 Air Purging and Leakage Test

1. Connect charging hose of manifold valve to charge end of low pressure valve (both high/low pressure valves must be tightly shut).
2. Connect joint of charging hose to vacuum pump.
3. Fully open the handle of Lo manifold valve.
4. Open the vacuum pump for vacuumization. At the beginning, slightly loosen joint nut of low pressure valve to check if there is air coming inside (If noise of vacuum pump has been changed, the reading of multimeter is 0). Then tighten the nut.
5. Keep vacuuming for more than 15mins and make sure the reading of multi-meter is -14.5PSI(-29.9in.Hg).
6. Fully open high/low pressure valves.
7. Remove charging hose from charging end of low pressure valve.
8. Tighten lid of low pressure valve. (As shown in Fig.6)

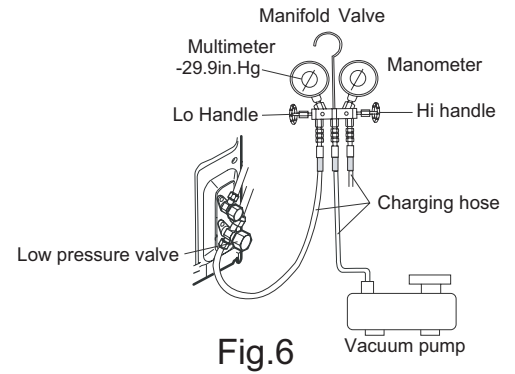
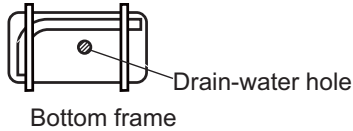

Fig.6

7.4.3 Outdoor Condensate Drainage (only for Heat pump unit)

During heating operation, the condensate and defrosting water should be drained out reliably through the drain hose. Install the outdoor drain connector in a $\Phi 9.8$ in. hole on the base plate and attach the drain hose to the connector so that the waste water formed in the outdoor unit can be drained out. The hole diameter 9.8in. must be plugged. Whether to plug other holes will be determined by the dealers according to actual conditions.

09、12K Unit



Bottom frame

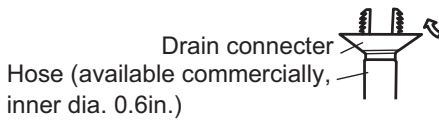

18、24K Unit

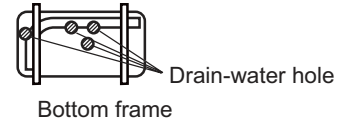

Bottom frame

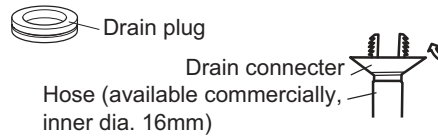

7.5 Check after Installation and Operation Test

7.5.1 Check after Installation

Items to be checked	Possible malfunction
Has it been fixed firmly?	The unit may drop, shake or emit noise.
Have you done the refrigerant leakage test?	It may cause insufficient cooling(heating) capacity
Is heat insulation sufficient?	It may cause condensation and dripping.
Is water drainage satisfactory?	It may cause condensation and dripping.
Is the voltage in accordance with the rated voltage marked on the nameplate?	It may cause electric malfunction or damage the product.
Is the electric wiring and piping connection installed correctly and securely?	It may cause electric malfunction or damage the part.
Has the unit been connected to a secure earth connection?	It may cause electrical leakage.
Is the power cord specified?	It may cause electric malfunction or damage the part.
Are the inlet and outlet openings blocked?	It may cause insufficient cooling(heating) capacity.
Is the length of connection pipes and refrigerant capacity been recorded?	The refrigerant capacity is not accurate.

7.5.2 Operation Test

1. Before Operation Test

- (1) Do not switch on power before installation is finished completely.
- (2) Electric wiring must be connected correctly and securely.
- (3) Cut-off valves of the connection pipes should be opened.
- (4) All the impurities such as scraps and thrams must be cleared from the unit.

2. Operation Test Method

- (1) Switch on power and press "ON/OFF" button on the remote controller to start operation.
- (2) Press MODE button to select the COOL, HEAT (Not available for cooling only unit), FAN to check whether the operation is normal or not.

7.6 Installation and Maintenance of Healthy Filter

7.6.1 Installation of Healthy Filter

1. Lift up the front panel from its two ends, as shown by the arrow direction, and then remove the air filter. (As shown in fig.a)

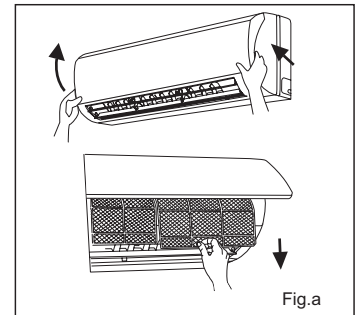

Fig.a

2. Attach the healthy filter onto the air filter. (As shown in fig.b)

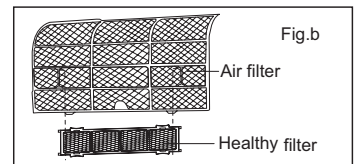

Fig.b

3. Install the air filter properly along the arrow direction in Fig.c, and then close the panel .

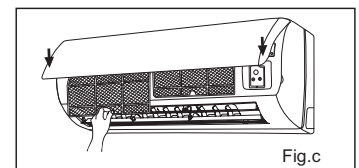

Fig.c

7.6.2 Cleaning and Maintenance

Remove the healthy filter and reinstall it after cleaning according to the installation instruction. Don't use brush or hard things to clean the filter. After cleaning, be sure to dry it in the shade.

7.6.3 Service Life

The general service life for the healthy filter is about one year under normal condition. As for silver ion filter, it is invalid when its surface becomes black (green).

- This supplementary instruction is provided for reference to the unit with healthy filter. If the graphics provided herein is different from the actual product, please refer to the actual product. The quantity of healthy filters is based on the actual delivery.

8. Exploded Views and Parts List

8.1 Indoor Unit

(1)09&12K Unit

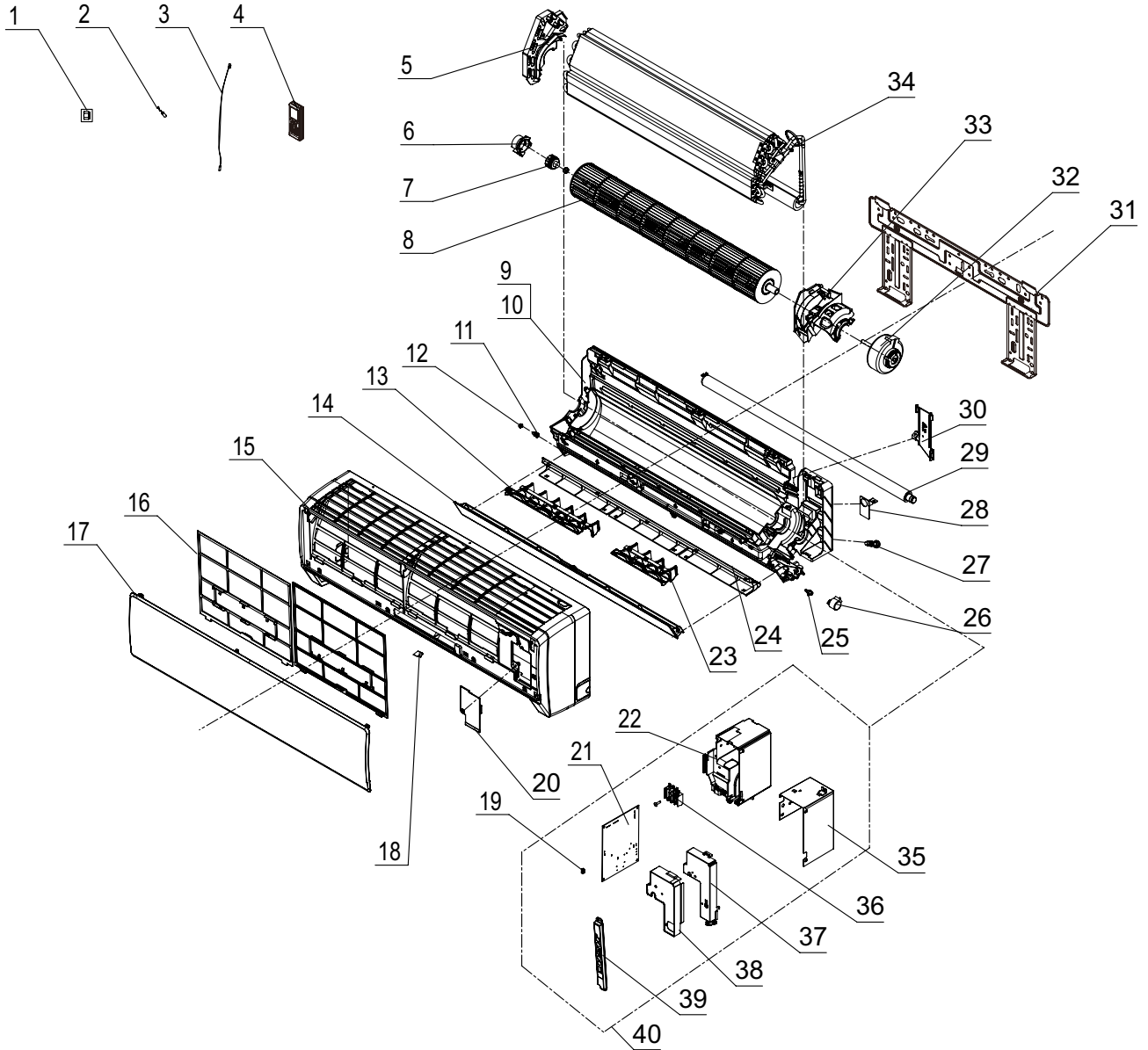

NO.	Description	Part Code		Qty
		GWC09MB-D3DNA3D/I	GWC12MB-D3DNA3D/I	
		Product Code	Product Code	
		CB171N06600	CB171N06700	
1	Pipe Connection Nut Accessories	06320020	06320020	1
2	Temperature Sensor	390000591	390000591	1
3	Ambient Temperature Sensor	390000453	390000453	1
4	Remote Controller	305100482	305100482	1
5	Evaporator Support	24212091	24212091	1
6	Ring of Bearing	26152022	26152022	1
7	O-Gasket sub-assy of Bearing	76512051	76512051	1
8	Cross Flow Fan	10352017	10352017	1
9	Rear Case assy	2220210309	2220210309	1
10	Rear Case	2220245405	2220245405	1
11	Axile Bush	10542036	10542036	1
12	Left Axile Bush	10512037	10512037	1
13	Air Louver 1	10512164	10512164	1
14	Guide Louver	10512157	10512157	1
15	Front Case Sub-assy	2001213931	2001213931	1
16	Filter Sub-Assy	1112220403	1112220403	2
17	Front Panel Sub-Assy	20012548	20012548	1
18	Screw Cover	24252016	24252016	1
19	Jumper	4202300107	4202300108	1
20	Electric Box Cover2	2012207504	2012207504	1
21	Main Board	30148208	30148208	1
22	Electric Box	2011216702	2011216702	1
23	Air Louver 2	10512165	10512165	1
24	Helicoid Tongue	26112163	26112163	1
25	Crank	10582070	10582070	1
26	Step Motor	1521212901	1521212901	1
27	Rubber Plug (Water Tray)	76712012	76712012	1
28	Cable Cross Plate	02122019	02122019	1
29	Drainage Hose	0523001401	0523001401	1
30	Pipe Clamp	26112164	26112164	1
31	Wall Mounting Frame	01252021	01252021	1
32	Fan Motor	15012089	15012089	1
33	Motor Press Plate	26112161	26112161	1
34	Evaporator Assy	0100232101	0100232101	1
35	Lower Shield Sub-assy of Electric Box	01592072	01592072	1
36	Terminal Board	42011233	42011233	1
37	Electric Box Cover1	20122103	20122103	1
38	Shield Cover of Electric Box Sub-assy	01592073	01592073	1
39	Display Board	30565007	30565007	1
40	Electric Box Assy	20302408	20302406	1

The data above are subject to change without notice.

Exploded Views and Parts List

NO.	Description	Part Code			Qty
		GWH09MB-D3DNA3D/I	GWH12MB-D3DNA3D/I	GWH09MB-D3DNA4D/I	
	Product Code	CB171N04500	CB171N04600	CB161N04800	
1	Pipe Connection Nut Accessories	06320020	06320020	06320020	1
2	Temperature Sensor	390000591	390000591	390000591	1
3	Ambient Temperature Sensor	390000453	390000453	390000453	1
4	Remote Controller	305100482	305100482	305100482	1
5	Evaporator Support	24212091	24212091	24212091	1
6	Ring of Bearing	26152022	26152022	26152022	1
7	O-Gasket sub-assy of Bearing	76512051	76512051	76512051	1
8	Cross Flow Fan	10352017	10352017	10352017	1
9	Rear Case assy	2220210309	2220210309	2220210309	1
10	Rear Case	2220245405	2220245405	2220245405	1
11	Axile Bush	10542008	10542008	10542036	1
12	Left Axile Bush	10512037	10512037	10512037	1
13	Air Louver 1	10512164	10512164	10512164	1
14	Guide Louver	10512157	10512157	10512157	1
15	Front Case Sub-assy	2001213931	2001213931	2001213931	1
16	Filter Sub-Assy	1112220403	1112220403	1112220403	2
17	Front Panel Sub-Assy	20012548	20012548	20012557	1
18	Screw Cover	24252016	24252016	24252016	1
19	Jumper	4202300107	4202300108	4202300107	1
20	Electric Box Cover2	2012207504	2012207504	2012207504	1
21	Main Board	30138655	30138655	30138655	1
22	Electric Box	2011216702	2011216702	2011216702	1
23	Air Louver 2	10512165	10512165	10512165	1
24	Helicoid Tongue	26112163C	26112163	26112163C	1
25	Crank	10582070	10582070	10582070	1
26	Step Motor	1521212901	1521212901	1521212901	1
27	Rubber Plug (Water Tray)	76712012	76712012	76712012	1
28	Cable Cross Plate	02122019	02122019	02122019	1
29	Drainage Hose	0523001401	0523001401	0523001401	1
30	Pipe Clamp	26112164	26112164	26112164	1
31	Wall Mounting Frame	01252021	01252021	01252021	1
32	Fan Motor	15012089	15012089	15012089	1
33	Motor Press Plate	26112161	26112161	26112161	1
34	Evaporator Assy	0100232101	0100232101	0100232101	1
35	Lower Shield Sub-assy of Electric Box	01592072	01592072	01592072	1
36	Terminal Board	42011233	42011233	42011233	1
37	Electric Box Cover1	20122103	20122103	22242135	1
38	Shield Cover of Electric Box Sub-assy	01592073	01592073	01592073	1
39	Display Board	30565007	30565007	30565012	1
40	Electric Box Assy	20302268	2030226801	20402206	1

The data above are subject to change without notice.

(2)GWC18MC-D3DNA3D/I、GWH18MC-D3DNA3D/I
 GWC18MC-D3DNA4D/I、GWH18MC-D3DNA4D/I
 GWC18MC-D3DNA5D/I、GWH18MC-D3DNA5D/I
 GWC18MC-D3DND3D/I、GWH18MC-D3DND3D/I
 GWC18MC-D3DNC1D/I

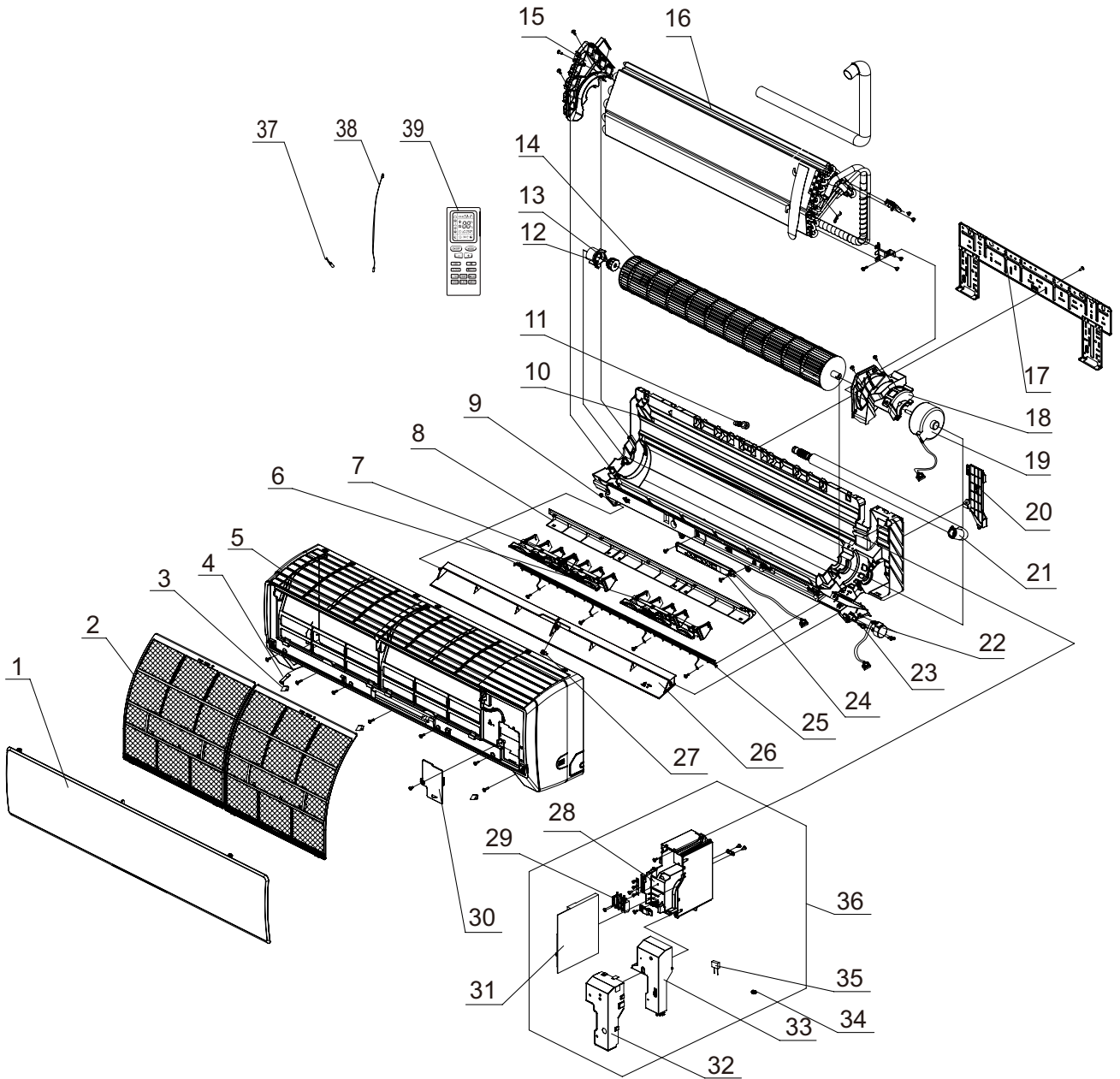

Exploded Views and Parts List

NO.	Description	Part Code		Qty
		GWC18MC-D3DNA3D/I	GWH18MC-D3DNA3D/I	
		Product Code	Product Code	
		CB171N06800	CB171N04700	
1	Front Panel Assy	20012260	20012260	1
2	Filter Sub-Assy	1112208901	1112208901	2
3	Screw Cover	24252016	24252016	3
4	Baffle Plate	26112228	26112228	1
5	Front Case Sub-assy	20022172	20012288	1
6	Air Louver 1	10512708	10512708	1
7	Air Louver 2	10512709	10512709	1
8	Helicoid Tongue	26112238	26112238	1
9	Left Axile Bush	10512037	10512037	1
10	Rear Case assy	22202128	22202128	1
11	Rubber Plug (Water Tray)	76712012	76712012	1
12	Ring of Bearing	26152022	26152022	1
13	O-Gasket sub-assy of Bearing	76512051	76512051	1
14	Cross Flow Fan	10352019	10352019	1
15	Evaporator Support	24212133	24212133	1
16	Evaporator Assy	01002575	01002575	1
17	Wall Mounting Frame	01252218	01252218	1
18	Motor Press Plate	26112178	26112178	1
19	Fan Motor	1501211601	1501211601	1
20	Pipe Clamp	26112164	26112164	1
21	Drainage Hose	05230014	05230014	1
22	Step Motor	15012086	15012086	1
23	Crank	10582070	10582070	1
24	Display Board	30565038	30565038	1
25	Mesh Enclosure(Air Outlet)	01472015	01472015	1
26	Guide Louver	10512115	10512115	1
27	Axile Bush	10542036	10542008	1
28	Electric Box	2011210801	2011210801	1
29	Terminal Board	42011233	42011233	1
30	Electric Box Cover2	20112081	20112081	1
31	Main Board	30148341	30138649	1
32	Shield Cover of Electric Box	01592092	01592092	1
33	Electric Box Cover1	20122154	20122128	1
34	Jumper	4202300109	4202300109	1
35	Capacitor CBB61	33010043	33010043	1
36	Electric Box Assy	20302427	2020210511	1
37	Ambient Temperature Sensor	390000453	390000453	1
38	Temperature Sensor	390000591	390000591	1
39	Remote Controller	305100482	305100482	1

The data above are subject to change without notice.

NO.	Description	Part Code		Qty
		GWC18MC-D3DNA4D/I	GWH18MC-D3DNA4D/I	
		Product Code	Product Code	
		CB161N05100	CB161N05200	
1	Front Panel Assy	20012280	20012280	1
2	Filter Sub-Assy	1112208901	1112208901	2
3	Screw Cover	24252016	24252016	3
4	Baffle Plate	26112228	26112228	1
5	Front Case Sub-assy	20022172	20022172	1
6	Air Louver 1	10512708	10512708	1
7	Air Louver 2	10512709	10512709	1
8	Helicoid Tongue	26112238	26112238	1
9	Left Axile Bush	10512037	10512037	1
10	Rear Case assy	22202128	22202128	1
11	Rubber Plug (Water Tray)	76712012	76712012	1
12	Ring of Bearing	26152022	26152022	1
13	O-Gasket sub-assy of Bearing	76512051	76512051	1
14	Cross Flow Fan	10352019	10352019	1
15	Evaporator Support	24212133	24212133	1
16	Evaporator Assy	01002575	01002575	1
17	Wall Mounting Frame	01252218	01252218	1
18	Motor Press Plate	26112494	26112494	1
19	Fan Motor	1501211601	1501211601	1
20	Pipe Clamp	26112164	26112164	1
21	Drainage Hose	05230014	05230014	1
22	Step Motor	15012086	15012086	1
23	Crank	10582070	10582070	1
24	Display Board	30565039	30565039	1
25	Mesh Enclosure(Air Outlet)	01472015	01472015	1
26	Guide Louver	10512115	10512115	1
27	Axile Bush	10542036	10542036	1
28	Electric Box	2011210802	2011210802	1
29	Terminal Board	42011233	42011233	1
30	Electric Box Cover2	2011208103	2011208103	1
31	Main Board	30148341	30138649	1
32	Shield Cover of Electric Box	01592092	01592092	1
33	Electric Box Cover1	20122154	20122154	1
34	Jumper	4202300109	4202300109	1
35	Capacitor CBB61	33010043	33010043	1
36	Electric Box Assy	20402219	20402220	1
37	Ambient Temperature Sensor	390000453	390000453	1
38	Temperature Sensor	390000591	390000591	1
39	Remote Controller	305100482	305100482	1

The data above are subject to change without notice.

Summary and Features

NO.	Description	Part Code		Qty
		GWC18MC-D3DNA5D/I	GWH18MC-D3DNA5D/I	
		Product Code	Product Code	
		CB162N05300	CB162N05400	
1	Front Panel Assy	20012286	20012286	1
2	Filter Sub-Assy	1112208901	1112208901	2
3	Screw Cover	24252016	24252016	3
4	Baffle Plate	26112228	26112228	1
5	Front Case Sub-assy	20022172	20022172	1
6	Air Louver 1	10512708	10512708	1
7	Air Louver 2	10512709	10512709	1
8	Helicoid Tongue	26112238	26112238	1
9	Left Axile Bush	10512037	10512037	1
10	Rear Case assy	22202128	22202128	1
11	Rubber Plug (Water Tray)	76712012	76712012	1
12	Ring of Bearing	26152022	26152022	1
13	O-Gasket sub-assy of Bearing	76512051	76512051	1
14	Cross Flow Fan	10352019	10352019	1
15	Evaporator Support	24212133	24212133	1
16	Evaporator Assy	01002575	01002575	1
17	Wall Mounting Frame	01252218	01252218	1
18	Motor Press Plate	26112494	26112494	1
19	Fan Motor	1501211601	1501211601	1
20	Pipe Clamp	26112164	26112164	1
21	Drainage Hose	05230014	05230014	1
22	Step Motor	15012086	15012086	1
23	Crank	10582070	10582070	1
24	Display Board	30565093	30565093	1
25	Mesh Enclosure(Air Outlet)	01472015	01472015	1
26	Guide Louver	10512115	10512115	1
27	Axile Bush	10542036	10542036	1
28	Electric Box	2011210802	2011210802	1
29	Terminal Board	42011233	42011233	1
30	Electric Box Cover2	2011208103	2011208103	1
31	Main Board	30148341	30138649	1
32	Shield Cover of Electric Box	01592092	01592092	1
33	Electric Box Cover1	20122154	20122154	1
34	Jumper	4202300109	4202300109	1
35	Capacitor CBB61	33010043	33010043	1
36	Electric Box Assy	20402221	20402222	1
37	Ambient Temperature Sensor	390000453	390000453	1
38	Temperature Sensor	390000591	390000591	1
39	Remote Controller	305100482	305100482	1

The data above are subject to change without notice.

NO.	Description	Part Code		Qty
		GWC18MC-D3DND3D/I	GWH18MC-D3DND3D/I	
		Product Code	Product Code	
		CB405N01600	CB405N01700	
1	Front Panel Assy	20012926	20012926	1
2	Filter Sub-Assy	1112208901	1112208901	2
3	Screw Cover	24252016	24252016	3
4	Baffle Plate	26112228	26112228	1
5	Front Case Sub-assy	20022205	20022205	1
6	Air Louver 1	10512708	10512708	1
7	Air Louver 2	10512709	10512709	1
8	Helicoid Tongue	26112238	26112238	1
9	Left Axile Bush	10512037	10512037	1
10	Rear Case assy	22202128	22202128	1
11	Rubber Plug (Water Tray)	76712012	76712012	1
12	Ring of Bearing	26152022	26152022	1
13	O-Gasket sub-assy of Bearing	76512051	76512051	1
14	Cross Flow Fan	10352019	10352019	1
15	Evaporator Support	24212133	24212133	1
16	Evaporator Assy	01002575	01002575	1
17	Wall Mounting Frame	01252218	01252218	1
18	Motor Press Plate	26112494	26112494	1
19	Fan Motor	1501211601	1501211601	1
20	Pipe Clamp	26112164	26112164	1
21	Drainage Hose	05230014	05230014	1
22	Step Motor	15012086	15012086	1
23	Crank	10582070	10582070	1
24	Display Board	30565145	30565145	1
25	Mesh Enclosure(Air Outlet)	01472015	01472015	1
26	Guide Louver	10512115	10512115	1
27	Axile Bush	10542036	10542036	1
28	Electric Box	2011210802	2011210802	1
29	Terminal Board	42011233	42011233	1
30	Electric Box Cover2	2011208103	2011208103	1
31	Main Board	30148341	30138649	1
32	Shield Cover of Electric Box	01592092	01592092	1
33	Electric Box Cover1	20122154	20122154	1
34	Jumper	4202300109	4202300109	1
35	Capacitor CBB61	33010043	33010043	1
36	Electric Box Assy	2030242703	2020210509	1
37	Ambient Temperature Sensor	390000453	390000453	1
38	Temperature Sensor	390000591	390000591	1
39	Remote Controller	305100482	305100482	1

The data above are subject to change without notice.

Summary and Features

NO.	Description	Part Code	Qty
		GWC18MC-D3DNC1D/I	
		Product Code CB139N04300	
1	Front Panel Assy	20012466	1
2	Filter Sub-Assy	1112208901	2
3	Screw Cover	24252016	3
4	Baffle Plate	26112228	1
5	Front Case Sub-assy	20022205	1
6	Air Louver 1	10512708	1
7	Air Louver 2	10512709	1
8	Helicoid Tongue	26112238	1
9	Left Axile Bush	10512037	1
10	Rear Case assy	22202128	1
11	Rubber Plug (Water Tray)	76712012	1
12	Ring of Bearing	26152022	1
13	O-Gasket sub-assy of Bearing	76512051	1
14	Cross Flow Fan	10352019	1
15	Evaporator Support	24212133	1
16	Evaporator Assy	01002575	1
17	Wall Mounting Frame	01252218	1
18	Motor Press Plate	26112494	1
19	Fan Motor	1501211601	1
20	Pipe Clamp	26112164	1
21	Drainage Hose	05230014	1
22	Step Motor	15012086	1
23	Crank	10582070	1
24	Display Board	30565088	1
25	Mesh Enclosure(Air Outlet)	01472015	1
26	Guide Louver	10512115	1
27	Axile Bush	10542036	1
28	Electric Box	2011210802	1
29	Terminal Board	42011233	1
30	Electric Box Cover2	2011208103	1
31	Main Board	30148341	1
32	Shield Cover of Electric Box	01592092	1
33	Electric Box Cover1	20122154	1
34	Jumper	4202300109	1
35	Capacitor CBB61	33010043	1
36	Electric Box Assy	20402226	1
37	Ambient Temperature Sensor	390000453	1
38	Temperature Sensor	390000591	1
39	Remote Controller	305100482	1

The data above are subject to change without notice.

(3)GWC18MC-D3DNA8D/I、GWH18MC-D3DNA8D/I、GWC18MC-D3DNE3D/I

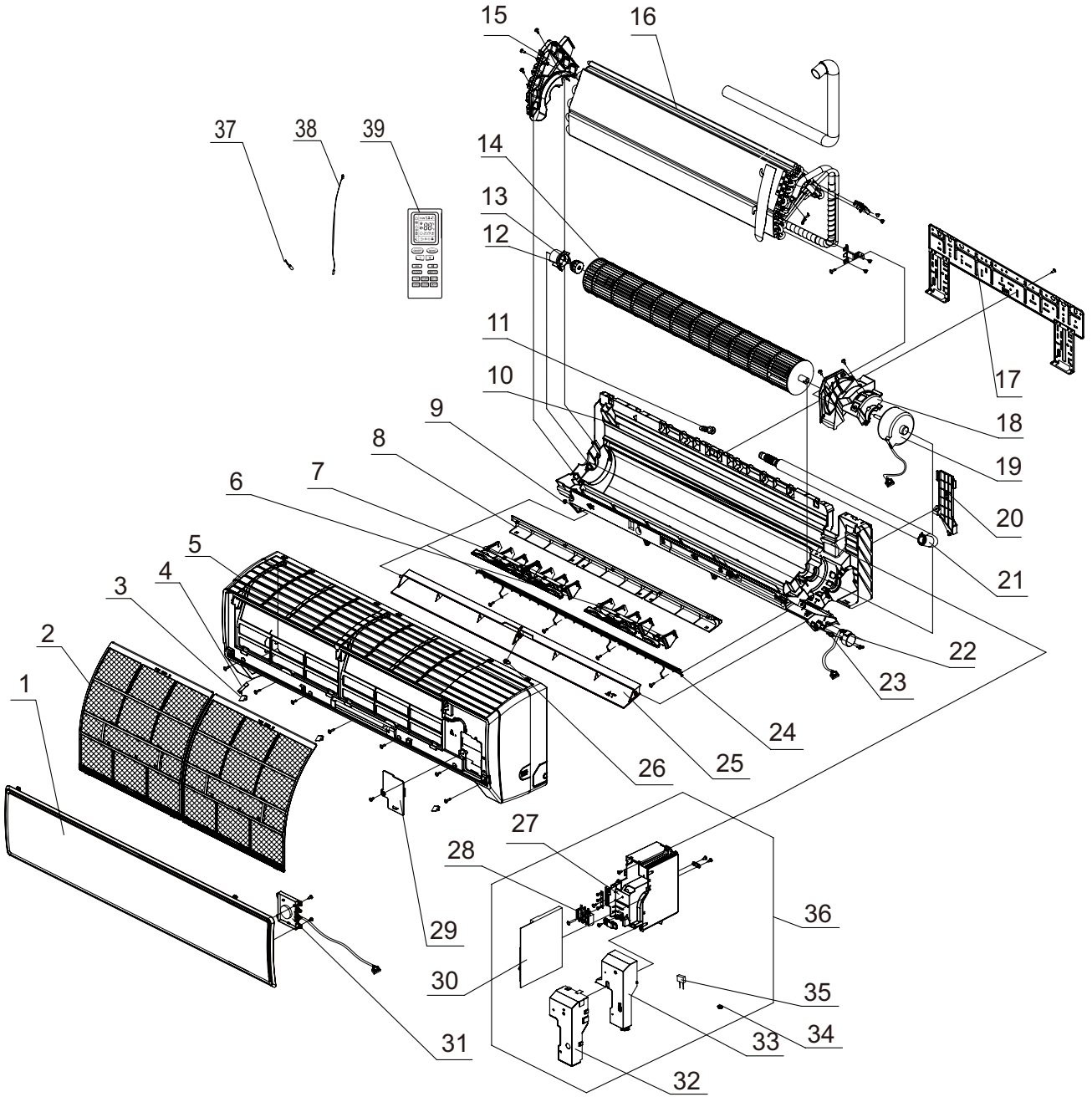

Exploded Views and Parts List

NO.	Description	Part Code	Qty
		GWC18MC-D3DNE3D/I	
	Product Code	CB404N01100	
1	Front Panel Assy	2001289801	1
2	Filter Sub-Assy	1112208901	2
3	Screw Cover	24252016	3
4	Baffle Plate	26112228	1
5	Front Case Sub-assy	20022205	1
6	Air Louver 1	10512708	1
7	Air Louver 2	10512709	1
8	Helicoid Tongue	26112238	1
9	Left Axile Bush	10512037	1
10	Rear Case assy	22202128	1
11	Rubber Plug (Water Tray)	76712012	1
12	Ring of Bearing	26152022	1
13	O-Gasket sub-assy of Bearing	76512051	1
14	Cross Flow Fan	10352019	1
15	Evaporator Support	24212133	1
16	Evaporator Assy	01002575	1
17	Wall Mounting Frame	01252218	1
18	Motor Press Plate	26112494	1
19	Fan Motor	1501211601	1
20	Pipe Clamp	26112164	1
21	Drainage Hose	05230014	1
22	Step Motor	15012086	1
23	Crank	10582070	1
24	Display Board	01472015	1
25	Mesh Enclosure(Air Outlet)	10512115	1
26	Guide Louver	10542036	1
27	Axile Bush	2011210802	1
28	Electric Box	42011233	1
29	Terminal Board	2011208103	1
30	Electric Box Cover2	30148341	1
31	Main Board	30565170	1
32	Shield Cover of Electric Box	01592092	1
33	Electric Box Cover1	20122154	1
34	Jumper	4202300109	1
35	Capacitor CBB61	33010043	1
36	Electric Box Assy	2030242701	1
37	Ambient Temperature Sensor	390000453	1
38	Temperature Sensor	390000591	1
39	Remote Controller	305100482	1

The data above are subject to change without notice.

NO.	Description	Part Code		Qty
		GWC18MC-D3DNA8D/I	GWH18MC-D3DNA8D/I	
		Product Code	Product Code	
		CB173N03600	CB173N03700	
1	Front Panel Assy	20012285	20012285	1
2	Filter Sub-Assy	1112208901	1112208901	2
3	Screw Cover	24252016	24252016	3
4	Baffle Plate	26112228	26112228	1
5	Front Case Sub-assy	20022205	20022205	1
6	Air Louver 1	10512708	10512708	1
7	Air Louver 2	10512709	10512709	1
8	Helicoid Tongue	26112238	26112238	1
9	Left Axile Bush	10512037	10512037	1
10	Rear Case assy	22202128	22202128	1
11	Rubber Plug (Water Tray)	76712012	76712012	1
12	Ring of Bearing	26152022	26152022	1
13	O-Gasket sub-assy of Bearing	76512051	76512051	1
14	Cross Flow Fan	10352019	10352019	1
15	Evaporator Support	24212133	24212133	1
16	Evaporator Assy	01002575	01002575	1
17	Wall Mounting Frame	01252218	01252218	1
18	Motor Press Plate	26112494	26112494	1
19	Fan Motor	1501211601	1501211601	1
20	Pipe Clamp	26112164	26112164	1
21	Drainage Hose	05230014	05230014	1
22	Step Motor	15012086	15012086	1
23	Crank	10582070	10582070	1
24	Display Board	01472015	01472015	1
25	Mesh Enclosure(Air Outlet)	10512115	10512115	1
26	Guide Louver	10542036	10542036	1
27	Axile Bush	2011210802	2011210802	1
28	Electric Box	42011233	42011233	1
29	Terminal Board	2011208103	2011208103	1
30	Electric Box Cover2	30148341	30138649	1
31	Main Board	3056504301	3056504301	1
32	Shield Cover of Electric Box	01592092	01592092	1
33	Electric Box Cover1	20122154	20122154	1
34	Jumper	4202300109	4202300109	1
35	Capacitor CBB61	33010043	33010043	1
36	Electric Box Assy	2030242702	20402166	1
37	Ambient Temperature Sensor	390000453	390000453	1
38	Temperature Sensor	390000591	390000591	1
39	Remote Controller	305100482	305100482	1

The data above are subject to change without notice.

Exploded Views and Parts List

(4)GWC24MD-D3DNA3D/I、GWH24MD-D3DNA3D/I
GWC24MD-D3DNA4D/I、GWH24MD-D3DNA4D/I
GWC24MD-D3DNA5D/I、GWH24MD-D3DNA5D/I
GWC24MD-D3DND3D/I、GWH24MD-D3DND3D/I

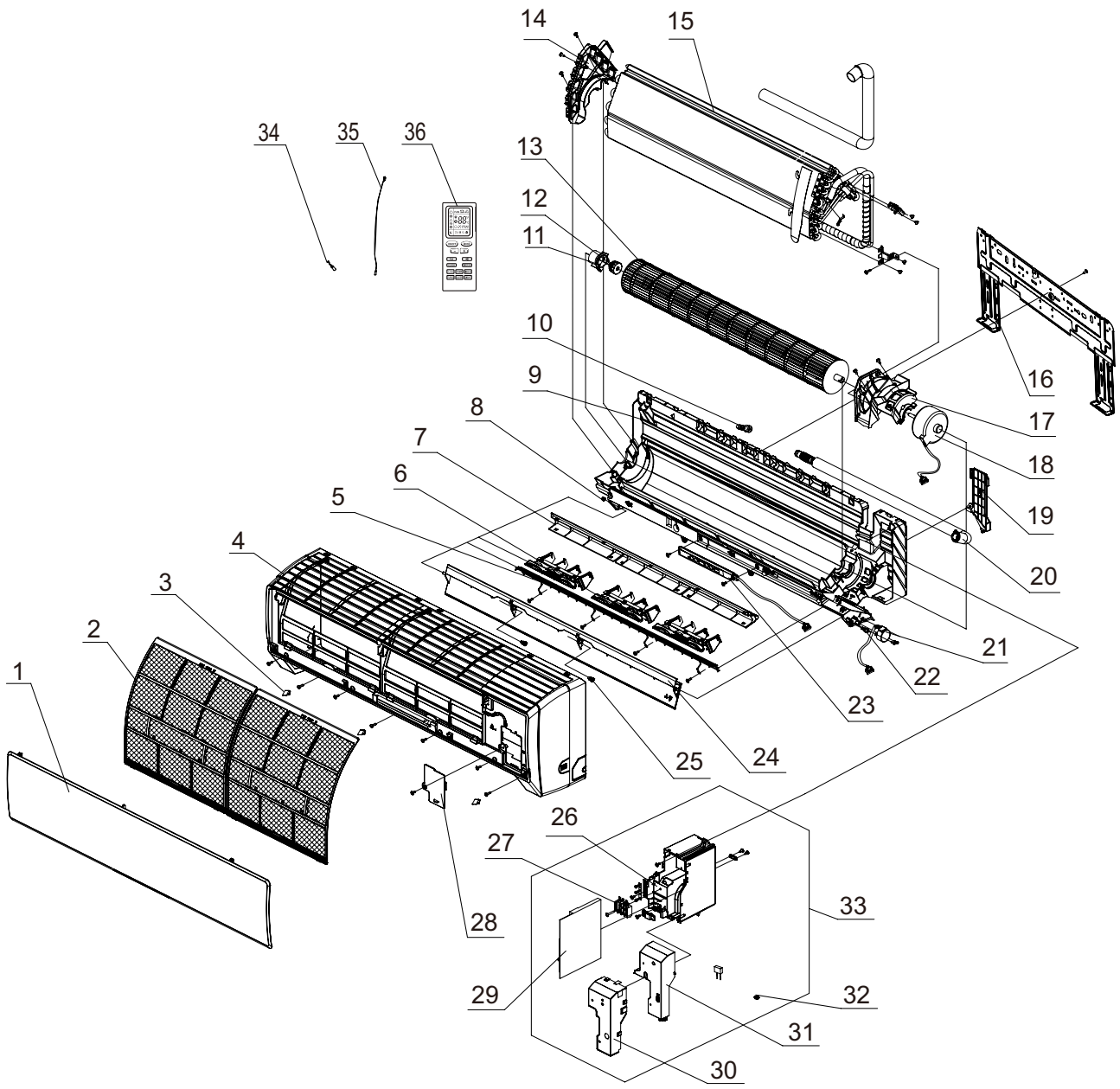

NO.	Description	Part Code		Qty
		GWC24MD-D3DNA3D/I	GWH24MD-D3DNA3D/I	
		Product Code	Product Code	
		CB171N06900	CB171N07000	
1	Front Panel Assy	20012328	20012328	1
2	Filter Sub-Assy	11122091	11122091	2
3	Screw Cover	24252016	24252016	3
4	Front Case Assy	2001232901	2001232901	1
5	Mesh Enclosure(Air Outlet)	01472016	01472016	1
6	Air Louver	10512141	10512141	3
7	Helicoid Tongue	26112187	26112187	1
8	Left Axile Bush	10512037	10512037	1
9	Rear Case assy	2220211701	2220211701	1
10	Rubber Plug (Water Tray)	76712012	76712012	1
11	Ring of Bearing	26152025	26152025	1
12	O-Gasket sub-assy of Bearing	76512051	76512051	1
13	Cross Flow Fan	10352030	10352030	1
14	Evaporator Support	24212103	24212103	1
15	Evaporator Assy	0100257204	0100257204	1
16	Wall Mounting Frame	01252032	01252032	1
17	Motor Press Plate	26112184	26112184	1
18	Fan Motor	15012136	15012136	1
19	Pipe Clamp	26112188	26112188	1
20	Drainage Hose	0523001401	0523001401	1
21	Step Motor	1521300101	1521300101	1
22	Crank	10582070	10582070	1
23	Display Board	30565038	30565038	1
24	Guide Louver	10512118	10512118	1
25	Axile Bush	10542036	10542036	2
26	Electric Box	2011210801	2011210801	1
27	Terminal Board	42011233	42011233	1
28	Electric Box Cover2	20112081	20112081	1
29	Main Board	30148235	30148236	1
30	Shield Cover of Electric Box	01592092	01592092	1
31	Electric Box Cover1	20122154	20122154	1
32	Jumper	4202300108	4202300108	1
33	Electric Box Assy	20302426	20302425	1
34	Ambient Temperature Sensor	390000451	390000451	1
35	Temperature Sensor	390000598	390000598	1
36	Remote Controller	305100482	305100482	1

The data above are subject to change without notice.

Exploded Views and Parts List

NO.	Description	Part Code		Qty
		GWC24MD-D3DNA4D/I	GWH24MD-D3DNA4D/I	
	Product Code	CB161N04500	CB161N04600	
1	Front Panel Assy	20012370	20012370	1
2	Filter Sub-Assy	11122091	11122091	2
3	Screw Cover	24252016	24252016	3
4	Front Case Assy	2001232901	2001232901	1
5	Mesh Enclosure(Air Outlet)	01472016	01472016	1
6	Air Louver	10512141	10512141	3
7	Helicoid Tongue	26112187	26112187	1
8	Left Axile Bush	10512037	10512037	1
9	Rear Case assy	2220211701	2220211701	1
10	Rubber Plug (Water Tray)	76712012	76712012	1
11	Ring of Bearing	26152025	26152025	1
12	O-Gasket sub-assy of Bearing	76512051	76512051	1
13	Cross Flow Fan	10352030	10352030	1
14	Evaporator Support	24212103	24212103	1
15	Evaporator Assy	0100257204	0100257204	1
16	Wall Mounting Frame	01252032	01252032	1
17	Motor Press Plate	26112316	26112316	1
18	Fan Motor	15012136	15012136	1
19	Pipe Clamp	26112188	26112188	1
20	Drainage Hose	0523001401	0523001401	1
21	Step Motor	1521300101	1521300101	1
22	Crank	10582070	10582070	1
23	Display Board	30565039	30565039	1
24	Guide Louver	10512118	10512118	1
25	Axile Bush	10542036	10542036	2
26	Electric Box	2011210802	2011210802	1
27	Terminal Board	42011233	42011233	1
28	Electric Box Cover2	2011208103	2011208103	1
29	Main Board	30148235	30148236	1
30	Shield Cover of Electric Box	01592092	01592092	1
31	Electric Box Cover1	20122154	20122154	1
32	Jumper	4202300108	4202300108	1
33	Electric Box Assy	2030242601	2030242501	1
34	Ambient Temperature Sensor	390000451	390000451	1
35	Temperature Sensor	390000598	390000598	1
36	Remote Controller	305100482	305100482	1

The data above are subject to change without notice.

NO.	Description	Part Code		Qty
		GWC24MD-D3DNA5D/I	GWH24MD-D3DNA5D/I	
	Product Code	CB162N05000	CB162N05100	
1	Front Panel Assy	20012368	20012368	1
2	Filter Sub-Assy	11122091	11122091	2
3	Screw Cover	24252016	24252016	3
4	Front Case Assy	2001232901	2001232901	1
5	Mesh Enclosure(Air Outlet)	01472016	01472016	1
6	Air Louver	10512141	10512141	3
7	Helicoid Tongue	26112187	26112187	1
8	Left Axile Bush	10512037	10512037	1
9	Rear Case assy	2220211701	2220211701	1
10	Rubber Plug (Water Tray)	76712012	76712012	1
11	Ring of Bearing	26152025	26152025	1
12	O-Gasket sub-assy of Bearing	76512051	76512051	1
13	Cross Flow Fan	10352030	10352030	1
14	Evaporator Support	24212103	24212103	1
15	Evaporator Assy	0100257204	0100257204	1
16	Wall Mounting Frame	01252032	01252032	1
17	Motor Press Plate	26112316	26112316	1
18	Fan Motor	15012136	15012136	1
19	Pipe Clamp	26112188	26112188	1
20	Drainage Hose	0523001401	0523001401	1
21	Step Motor	1521300101	1521300101	1
22	Crank	10582070	10582070	1
23	Display Board	30565041	30565041	1
24	Guide Louver	10512118	10512118	1
25	Axile Bush	10542036	10542036	2
26	Electric Box	2011210802	2011210802	1
27	Terminal Board	42011233	42011233	1
28	Electric Box Cover2	2011208103	2011208103	1
29	Main Board	30148235	30148236	1
30	Shield Cover of Electric Box	01592092	01592092	1
31	Electric Box Cover1	20122154	20122154	1
32	Jumper	4202300108	4202300108	1
33	Electric Box Assy	20402217	20402218	1
34	Ambient Temperature Sensor	390000451	390000451	1
35	Temperature Sensor	390000598	390000598	1
36	Remote Controller	305100482	305100482	1

The data above are subject to change without notice.

Exploded Views and Parts List

NO.	Description	Part Code		Qty
		GWC24MD-D3DND3D/I	GWH24MD-D3DND3D/I	
	Product Code	CB405N01800	CB405N01900	
1	Front Panel Assy	20012995	20012995	1
2	Filter Sub-Assy	11122091	11122091	2
3	Screw Cover	24252016	24252016	3
4	Front Case Assy	2001232903	2001232903	1
5	Mesh Enclosure(Air Outlet)	01472016	01472016	1
6	Air Louver	10512141	10512141	3
7	Helicoid Tongue	26112187	26112187	1
8	Left Axile Bush	10512037	10512037	1
9	Rear Case assy	2220211701	2220211701	1
10	Rubber Plug (Water Tray)	76712012	76712012	1
11	Ring of Bearing	26152025	26152025	1
12	O-Gasket sub-assy of Bearing	76512051	76512051	1
13	Cross Flow Fan	10352030	10352030	1
14	Evaporator Support	24212103	24212103	1
15	Evaporator Assy	0100257204	0100257204	1
16	Wall Mounting Frame	01252032	01252032	1
17	Motor Press Plate	26112316	26112316	1
18	Fan Motor	15012136	15012136	1
19	Pipe Clamp	26112188	26112188	1
20	Drainage Hose	0523001401	0523001401	1
21	Step Motor	1521300101	1521300101	1
22	Crank	10582070	10582070	1
23	Display Board	30565145	30565145	1
24	Guide Louver	10512118	10512118	1
25	Axile Bush	10542036	10542036	2
26	Electric Box	2011210802	2011210802	1
27	Terminal Board	42011233	42011233	1
28	Electric Box Cover2	2011208103	2011208103	1
29	Main Board	30148235	30148236	1
30	Shield Cover of Electric Box	01592092	01592092	1
31	Electric Box Cover1	20122154	20122154	1
32	Jumper	4202300108	4202300108	1
33	Electric Box Assy	2030242604	2030242503	1
34	Ambient Temperature Sensor	390000451	390000451	1
35	Temperature Sensor	390000598	390000598	1
36	Remote Controller	305100482	305100482	1

The data above are subject to change without notice.

(5)GWC24MD-D3DNA8D/I、GWH24MD-D3DNA8D/I、GWC24MD-D3DNE3D/I、GWC24MD-D3DNC1D/I

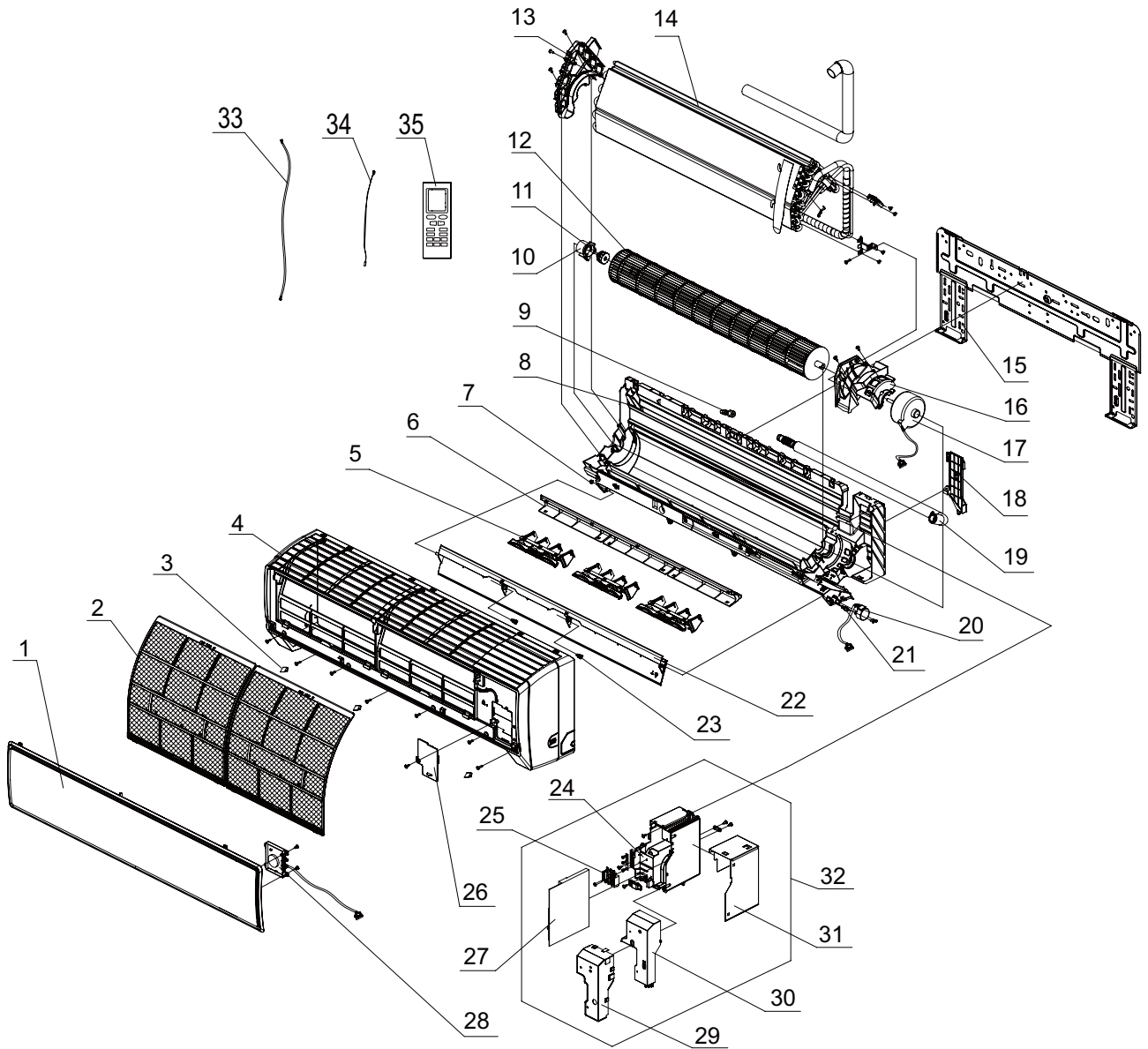

Exploded Views and Parts List

NO.	Description	Part Code		Qty
		GWC24MD-D3DNA8D/I	GWH24MD-D3DNA8D/I	
	Product Code	CB173N03800	CB173N03900	
1	Front Panel Assy	20012372	20012372	1
2	Filter Sub-Assy	11122091	11122091	2
3	Screw Cover	24252016	24252016	3
4	Front Case	2001229503	2001229503	1
5	Air Louver	10512141	10512141	3
6	Helicoid Tongue	26112187	26112187	1
7	Left Axile Bush	10512037	10512037	1
8	Rear Case assy	2220211701	2220211701	1
9	Rubber Plug (Water Tray)	76712012	76712012	1
10	O-Gasket sub-assy of Bearing	76512051	76512051	1
11	O-Gasket of Cross Fan Bearing	76512203	76512203	1
12	Cross Flow Fan	10352030	10352030	1
13	Evaporator Support	24212103	24212103	1
14	Evaporator Assy	0100257204	0100257204	1
15	Wall Mounting Frame	01252032	01252032	1
16	Motor Press Plate	26112316	26112316	1
17	Fan Motor	15012136	15012136	1
18	Pipe Clamp	26112188	26112188	1
19	Drainage Hose	0523001401	0523001401	1
20	Step Motor	1521300101	1521300101	1
21	Crank	10582070	10582070	1
22	Guide Louver	10512118	10512118	1
23	Axile Bush	10542036	10542036	2
24	Electric Box	2011210802	2011210802	1
25	Terminal Board	42011233	42011233	1
26	Electric Box Cover2	2011208103	20112081	1
27	Main Board	30148235	30148236	1
28	Display Board	3056504301	3056504301	1
29	Shield Cover of Electric Box	01592092	01592092	1
30	Electric Box Cover1	20122154	20122154	1
31	Lower Shield of Electric Box	01592091	01592091	1
32	Electric Box Assy	2030242603	2030242502	1
33	Ambient Temperature Sensor	390000451	390000451	1
34	Temperature Sensor	390000598	390000598	1
35	Remote Controller	305100482	305100482	1

The data above are subject to change without notice.

NO.	Description	Part Code		Qty
		GWC24MD-D3DNC1D/I	GWC24MD-D3DNE3D/I	
		Product Code	Product Code	
		CB139N04400	CB404N01200	
1	Front Panel Assy	20012552	2002207001	1
2	Filter Sub-Assy	11122091	11122091	2
3	Screw Cover	24252016	24252016	3
4	Front Case	2001229503	2001229503	1
5	Air Louver	10512141	10512141	3
6	Helicoid Tongue	26112187	26112187	1
7	Left Axile Bush	10512037	10512037	1
8	Rear Case assy	2220211701	2220211701	1
9	Rubber Plug (Water Tray)	76712012	76712012	1
10	O-Gasket sub-assy of Bearing	76512051	76512051	1
11	O-Gasket of Cross Fan Bearing	76512203	76512203	1
12	Cross Flow Fan	10352030	10352030	1
13	Evaporator Support	24212103	24212103	1
14	Evaporator Assy	0100257204	0100257204	1
15	Wall Mounting Frame	01252032	01252032	1
16	Motor Press Plate	26112316	26112316	1
17	Fan Motor	15012136	15012136	1
18	Pipe Clamp	26112188	26112188	1
19	Drainage Hose	0523001401	0523001401	1
20	Step Motor	1521300101	1521300101	1
21	Crank	10582070	10582070	1
22	Guide Louver	10512118	10512118	1
23	Axile Bush	10542036	10542036	2
24	Electric Box	2011210802	2011210802	1
25	Terminal Board	42011233	42011233	1
26	Electric Box Cover2	2011208103	2011208103	1
27	Main Board	30148235	30148235	1
28	Display Board	30565088	30565170	1
29	Shield Cover of Electric Box	01592092	01592092	1
30	Electric Box Cover1	20122154	20122154	1
31	Lower Shield of Electric Box	01592091	01592091	1
32	Electric Box Assy	20402278	2030242602	1
33	Ambient Temperature Sensor	390000451	390000451	1
34	Temperature Sensor	390000598	390000598	1
35	Remote Controller	305100482	305100482	1

The data above are subject to change without notice.

8.2 Outdoor Unit

(1)GWC09MB-D3DNA3D/O

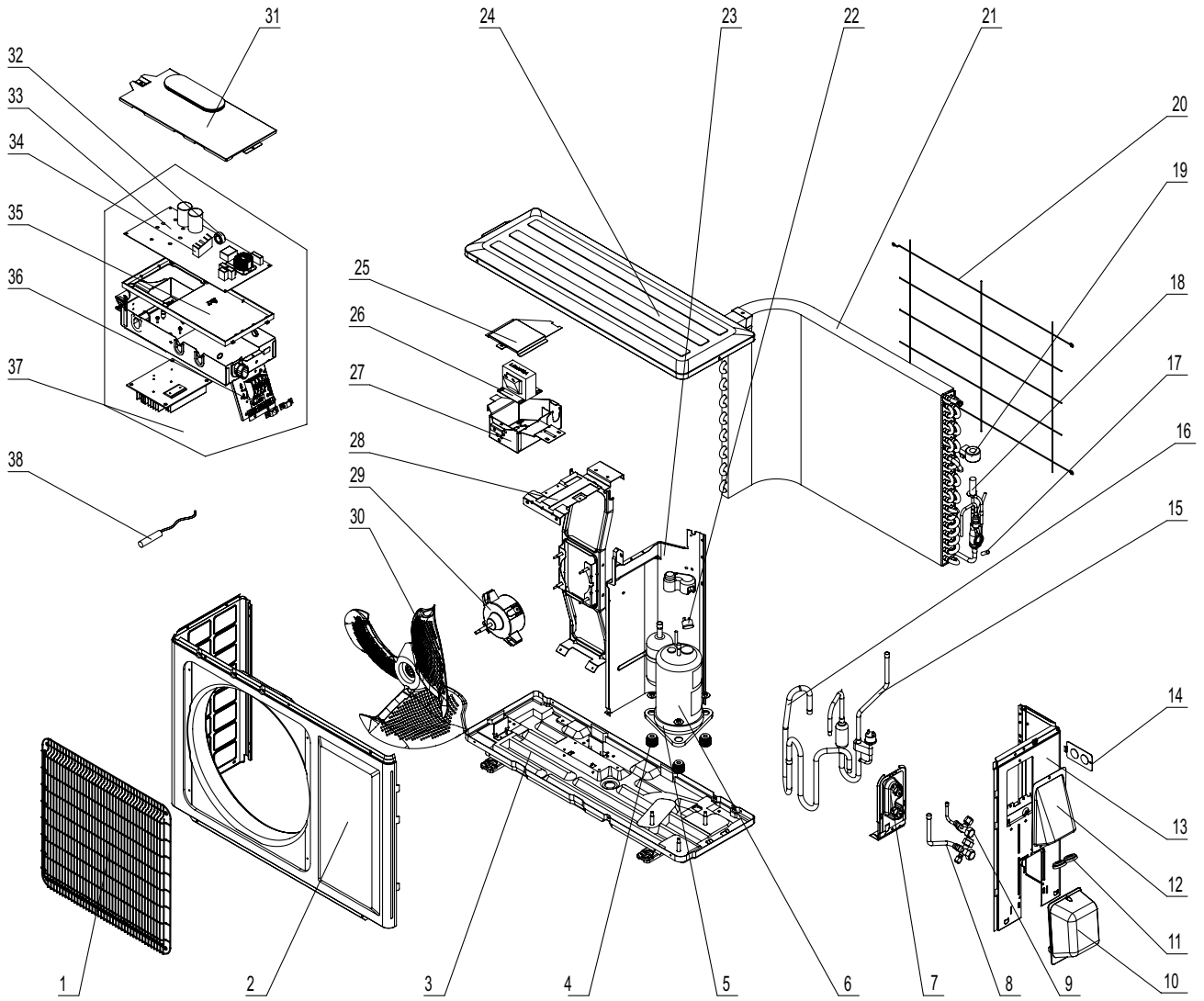

NO.	Description	Part Code	Qty
		GWC09MB-D3DNA3D/O	
Product Code		CB171W06600	
1	Front Grill	01473012	1
2	Cabinet	0143304601P	1
3	Chassis Sub-assy	02803077P	1
4	Compressor Gasket	76710290	3
5	Electric Heater	76513004	1
6	Compressor and Fittings	00103851	1
7	Valve Support	01713041	1
8	Valve	07100005	1
9	Valve	07100003	1
10	Valve Cover	2012300101	1
11	Cable Cross Loop	76510021	2
12	Cable Cross Plate Sub-assy	02123015	1
13	Right Side Plate Assy	013030712	1
14	Cover of Pass Wire	01413069	1
15	Discharge Tube Sub-assy	03833009	1
16	Inhalation Tube Sub-assy	03833006	1
17	Temp Sensor Sleeving	05212423	1
18	Electric Expansion Valve Sub-Assy	07133633	1
19	Magnet Coil	4300876701	1
20	Rear Grill	01473057	1
21	Condenser Assy	01163412	1
22	Compressor Overload Protector	00183066	1
23	Clapboard Sub-Assy	01233034	1
24	Top Cover Plate	01253443	1
25	Cover of Reactor Box	01413029	1
26	Reactor	43130185	1
27	Reactor Sub-assy	01403616	1
28	Motor Support Spot Welding Sub-assy	01703007	1
29	Fan Motor	15013159	1
30	Axial Flow Fan	10333012	1
31	Electric Box Cover Sub-Assy	0260309601	1
32	Magnetic Ring	49010104	1
33	Main Board	30148244	1
34	Radiator	49010252	1
35	Electric Box 1	20113005	1
36	Wire Clamp	71010003	2
37	Electric Box Assy	02603928	1
38	Temperature Sensor	39000310	1

The data above are subject to change without notice.

(2)GWH09MB-D3DNA3D/O

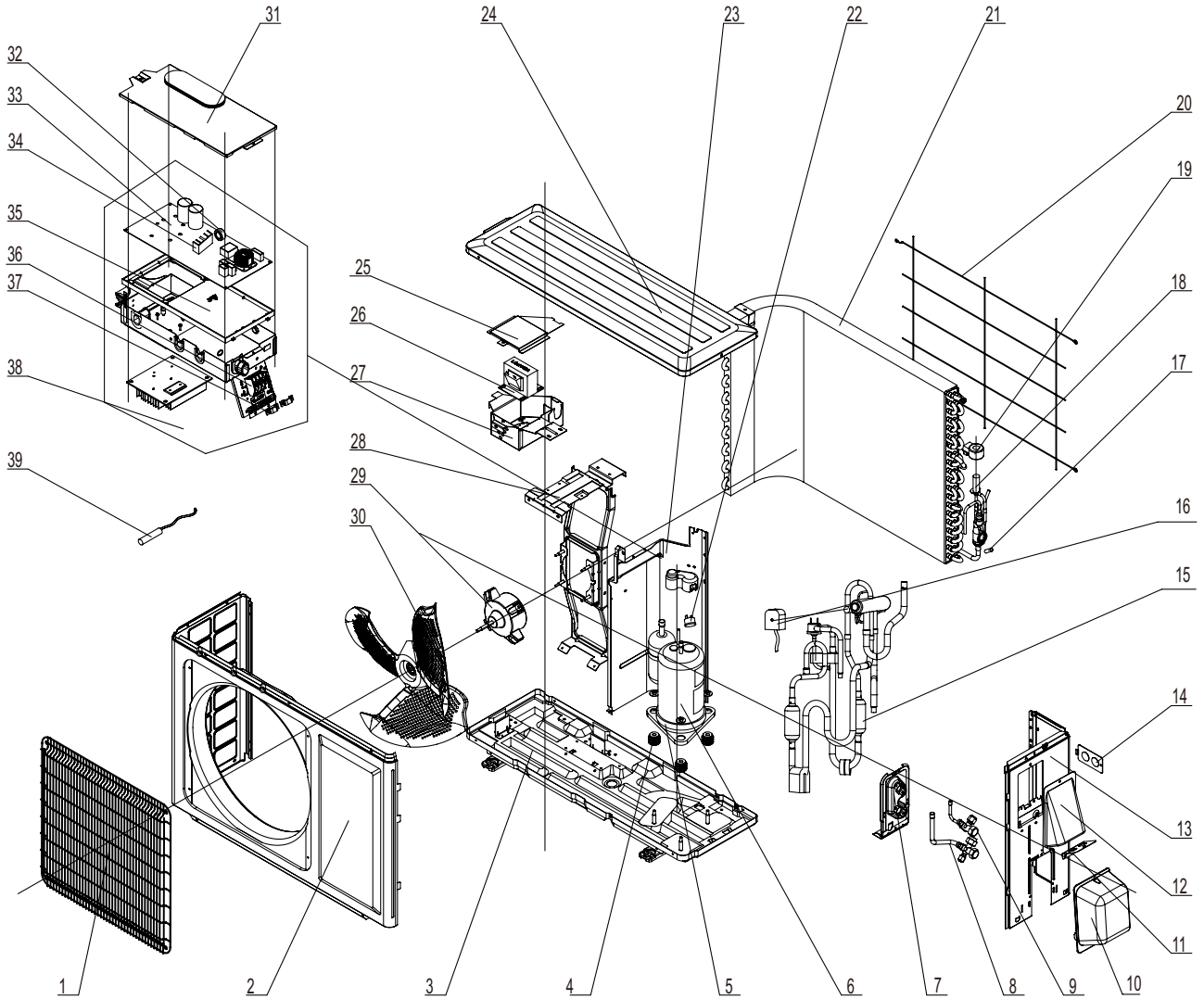

NO.	Description	Part Code	Qty
		GWH09MB-D3DNA3D/O	
	Product Code	CB171W04500	
1	Front Grill	01473012	1
2	Cabinet	0143304601P	1
3	Chassis Sub-assy	02803077P	1
4	Compressor Gasket	76710290	3
5	Electric Heater(Compressor)	76513004	1
6	Compressor and Fittings	00103851	1
7	Valve Support	01713041	1
8	Valve	07100005	1
9	Valve	07100003	1
10	Valve Cover	2012300101	1
11	Cable Cross Plate 1	02123013P	1
12	Cable Cross Plate 2	02123014P	1
13	Right Side Plate	0130306903	1
14	Cover of Pass Wire	01413069	1
15	4-Way Valve Assy	03123957	1
16	Magnet Coil	4300040047	1
17	Temp Sensor Sleeving	05212423	1
18	Electric Expansion Valve Sub-Assy	07133633	1
19	Magnet Coil	4300876701	1
20	Rear Grill	01473057	1
21	Condenser Assy	01163565	1
22	Compressor Overload Protector(External)	00183066	1
23	Clapboard Sub-Assy	01233034	1
24	Top Cover Plate	01253443	1
25	Cover of Reactor Box	01413029	1
26	Reactor	43130185	1
27	Reactor Sub-assy	01403616	1
28	Motor Support Spot Welding Sub-assy	01703007	1
29	Fan Motor	15013159	1
30	Axial Flow Fan	10333012	1
31	Electric Box Cover Sub-Assy	0260309601	1
32	Magnetic Ring	49010104	1
33	Main Board	30148245	1
34	Radiator	49010252	1
35	Electric Box 1	20113005	1
36	Terminal Board	42010313	1
37	Wire Clamp	71010003	2
38	Electric Box Assy	02613192	1
39	Temperature Sensor	39000310	1

The data above are subject to change without notice.

(3)GWH09MB-D3DNA3D/O(electric heating belt)

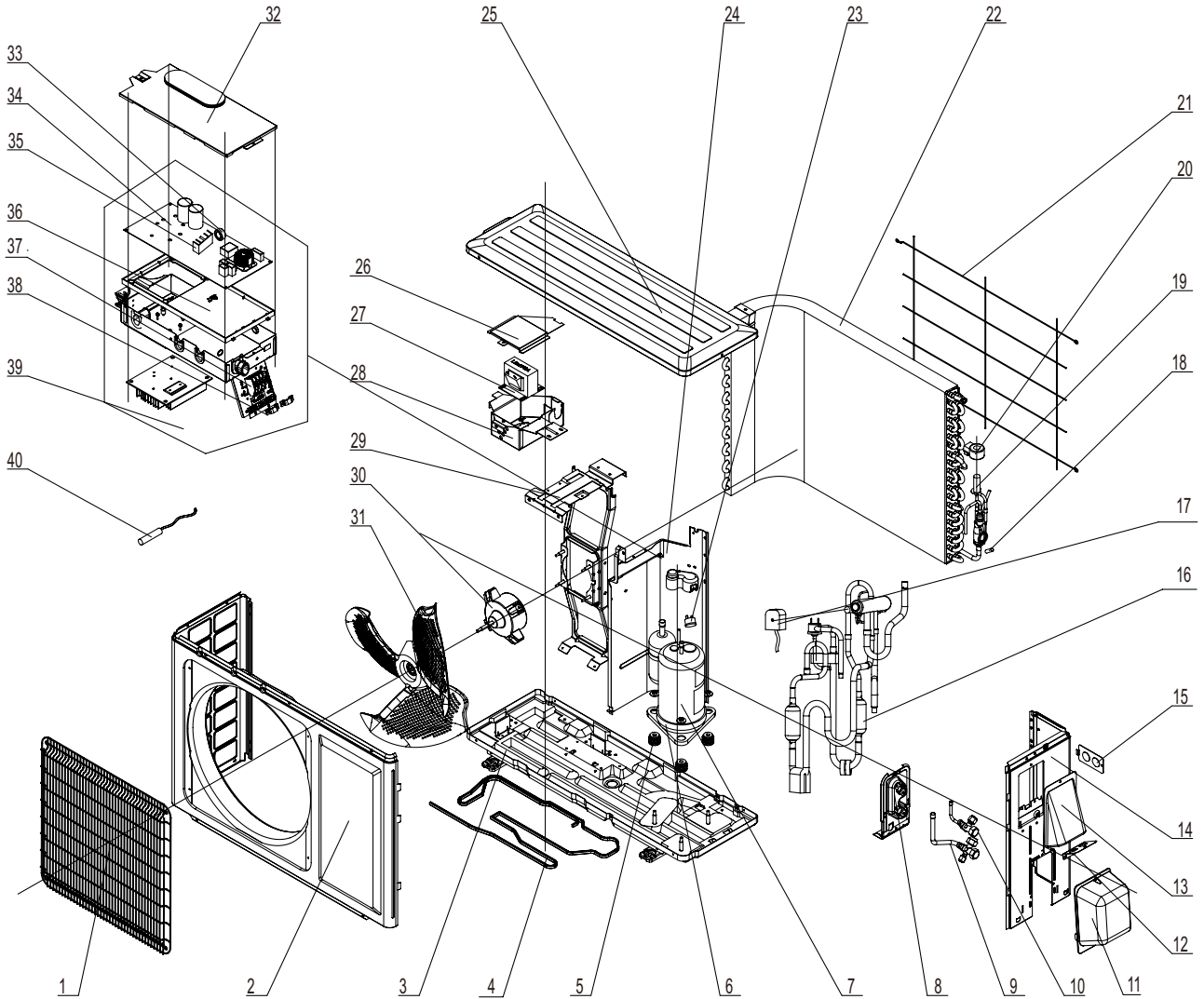

NO.	Description	Part Code		Qty
		GWH09MB-D3DNA3D/O(electric heating belt)		
		CB171W04501		
1	Front Grill	01473012		1
2	Cabinet	0143304601P		1
3	Chassis Sub-assy	02803076P		1
4	Electrical Heater (Chassis)	76510004		1
5	Compressor Gasket	76710290		3
6	Electric Heater(Compressor)	76513004		1
7	Compressor and Fittings	00103851		1
8	Valve Support	01713041		1
9	Valve	07100005		1
10	Valve	07100003		1
11	Valve Cover	2012300101		1
12	Cable Cross Plate 1	02123013P		1
13	Cable Cross Plate 2	02123014P		1
14	Right Side Plate Assy	013030712		1
15	Cover of Pass Wire	01413069		1
16	4-Way Valve Assy	03123957		1
17	Magnet Coil	4300040047		1
18	Temp Sensor Sleeving	05212423		1
19	Electric Expansion Valve Sub-Assy	07133633		1
20	Magnet Coil	4300876701		1
21	Rear Grill	01473057		1
22	Condenser Assy	01163565		1
23	Compressor Overload Proctector	00183066		1
24	Clapboard Sub-Assy	01233034		1
25	Top Cover Plate	01253443		1
26	Cover of Reactor Box	01413029		1
27	Reactor	43130185		1
28	Reactor Sub-assy	01403616		1
29	Motor Suport Spot Welding Sub-assy	01703007		1
30	Fan Motor	15013159		1
31	Axial Flow Fan	10333012		1
32	Electric Box Cover Sub-Assy	0260309601		1
33	Magnetic Ring	49010104		1
34	Main Board	30148246		1
35	Radiator	49010252		1
36	Terminal Board	42010313		1
37	Electric Box 1	20113005		1
38	Wire Clamp	71010003		2
39	Electric Box Assy	02603911		1
40	Temperature Sensor	39000310		1

The data above are subject to change without notice.

(4)GWC12MB-D3DNA3D/O

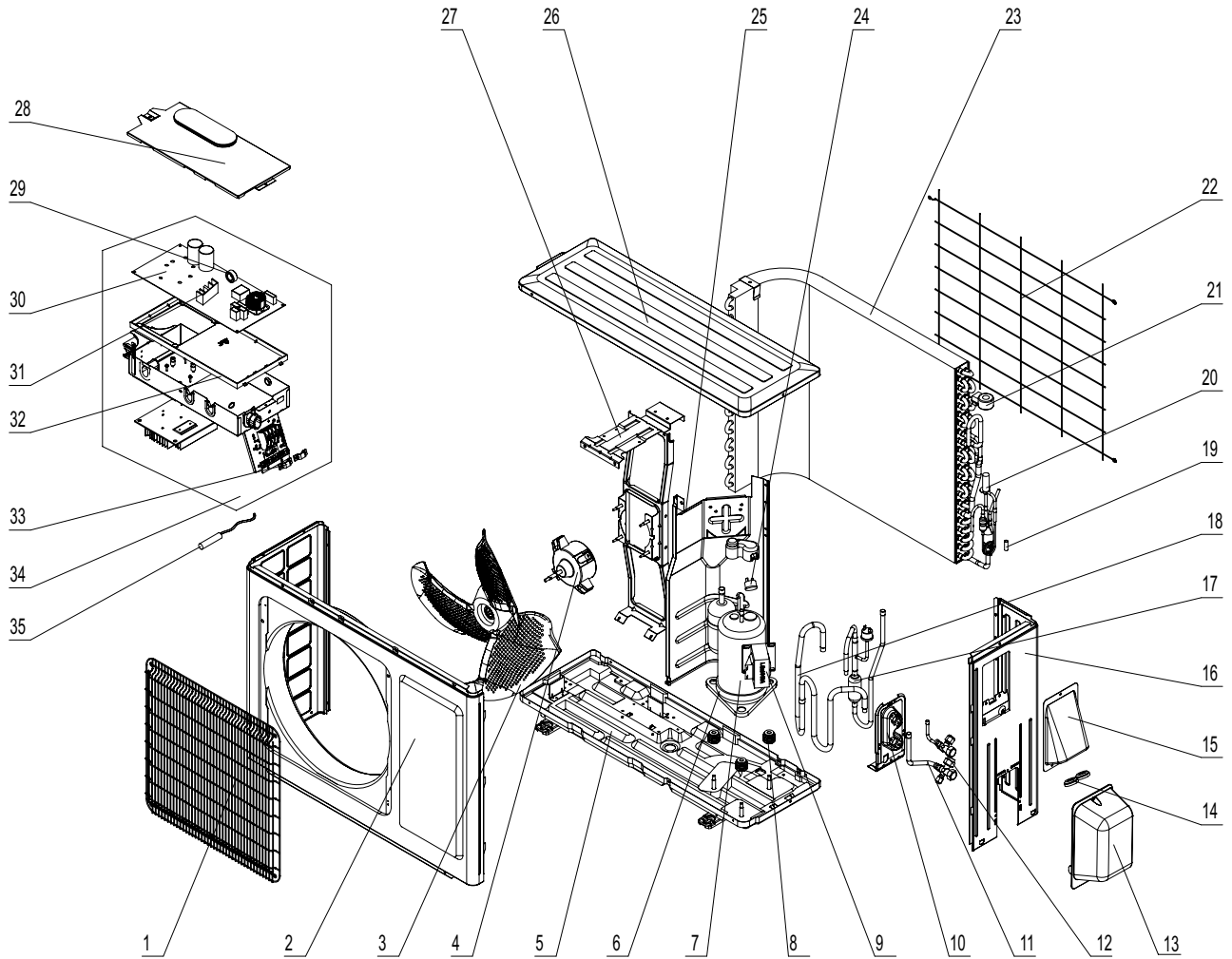

NO.	Description	Part Code		Qty
		GWC12MB-D3DNA3D/O		
		CB171W06700		
1	Front Grill	01473012		1
2	Front Panel	0153500201		1
3	Axial Flow Fan	10333012		1
4	Fan Motor	15013159		1
5	Chassis Sub-assy	02803077P		1
6	Electric Heater	76513004		1
7	Compressor and Fittings	00103851		1
8	Compressor Gasket	76710290		3
9	Reactor	43130185		1
10	Valve Support	01713041		1
11	Valve	07100005		1
12	Valve	07100003		1
13	Valve Cover	22243010		1
14	Cable Cross Loop	76510021		2
15	Cable Cross Plate Sub-assy	02123015		1
16	Right Side Plate	0130508401P		1
17	Discharge Tube Sub-assy	03833008		1
18	Inhalation Tube Sub-assy	03833006		1
19	Temp Sensor Sleeving	05212423		1
20	Electric Expansion Valve Sub-Assy	07133676		1
21	Magnet Coil	4300876701		1
22	Rear Grill	01475014		1
23	Condenser Assy	01163411		1
24	Compressor Overload Proctector	00183066		1
25	Clapboard Sub-Assy	01233090		1
26	Top Cover Plate	01253443		1
27	Motor Suport Spot Welding Sub-assy	0170301002		1
28	Electric Box Cover Sub-Assy	0260309601		1
29	Magnetic Ring	49010104		1
30	Main Board	30148247		1
31	Radiator	49010252		1
32	Electric Box 1	20113005		1
33	Wire Clamp	71010003		2
34	Electric Box Assy	02603927		1
35	Temperature Sensor	39000310		1

The data above are subject to change without notice.

(5)GWH12MB-D3DNA3D/O

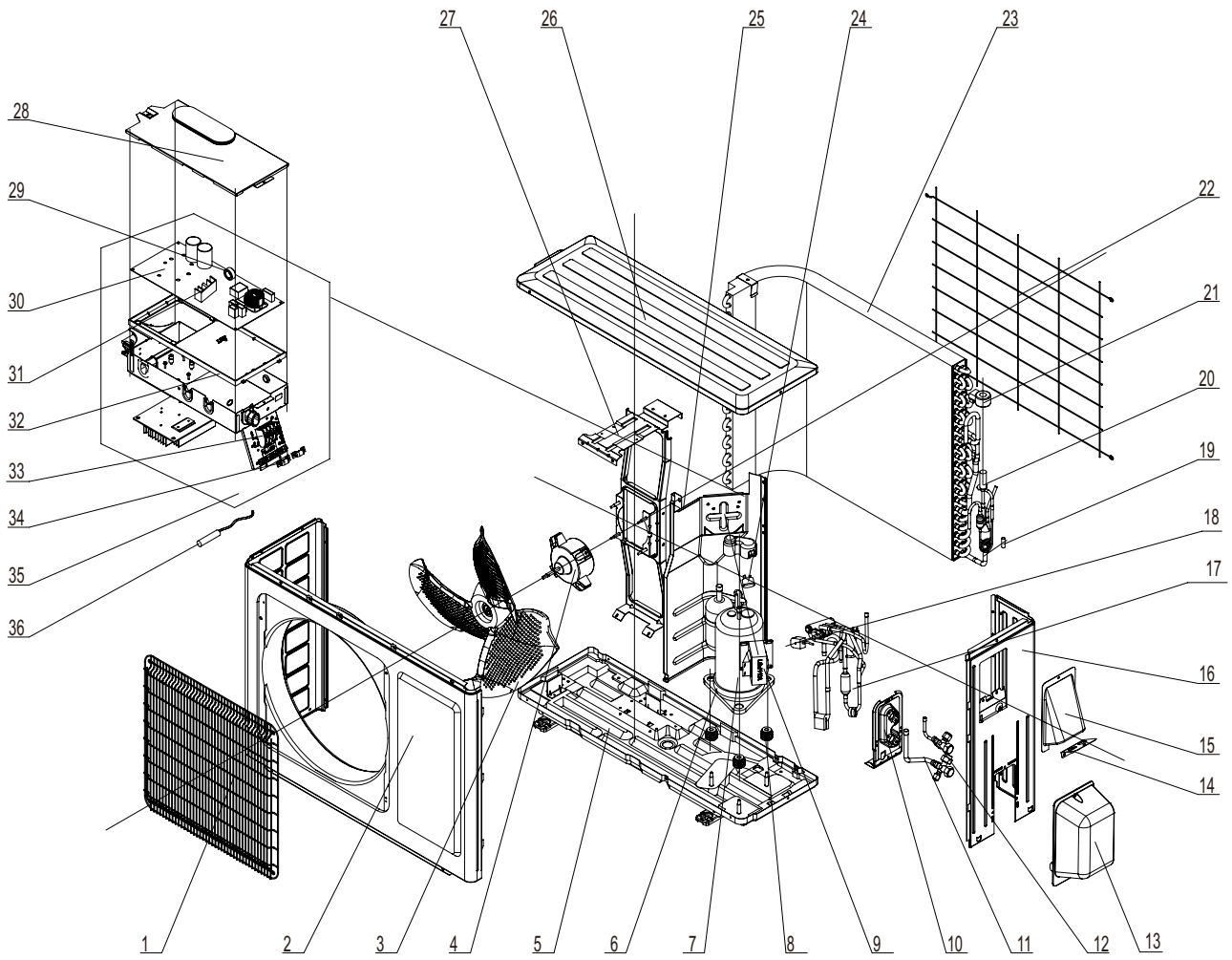

NO.	Description	Part Code	Qty
		GWH12MB-D3DNA3D/O	
		Product Code	
		CB171W04600	
1	Front Grill	01473012	1
2	Front Panel	0153501201	1
3	Axial Flow Fan	10333012	1
4	Fan Motor	15013159	1
5	Chassis Sub-assy	02803077P	1
6	Electric Heater	76513004	1
7	Compressor and Fittings	00103851	1
8	Compressor Gasket	76710290	3
9	Reactor	43130185	1
10	Valve Support	01713041	1
11	Valve	07100005	1
12	Valve	07100003	1
13	Valve Cover	22243010	1
14	Cable Cross Plate 1	02123013P	1
15	Cable Cross Plate 2	02123014P	1
16	Right Side Plate	0130509901P	1
17	4-Way Valve Assy	03123909	1
18	Magnet Coil	4300040047	1
19	Temp Sensor Sleeving	05212423	1
20	Electric Expansion Valve Sub-Assy	07133676	1
21	Magnet Coil	4300876701	1
22	Rear Grill	01475014	1
23	Condenser Assy	01163459	1
24	Compressor Overload Protector	00183066	1
25	Clapboard Sub-Assy	01233090	1
26	Top Cover Plate	01253443	1
27	Motor Support Spot Welding Sub-assy	0170301002	1
28	Electric Box Cover Sub-Assy	0260309601	1
29	Magnetic Ring	49010104	1
30	Main Board	30148248	1
31	Radiator	49010252	1
32	Electric Box 1	20113005	1
33	Terminal Board	42010313	1
34	Wire Clamp	71010003	2
35	Electric Box Assy	02613191	1
36	Temperature Sensor	39000310	1

The data above are subject to change without notice.

(6)GWH12MB-D3DNA3D/O(electric heating belt)

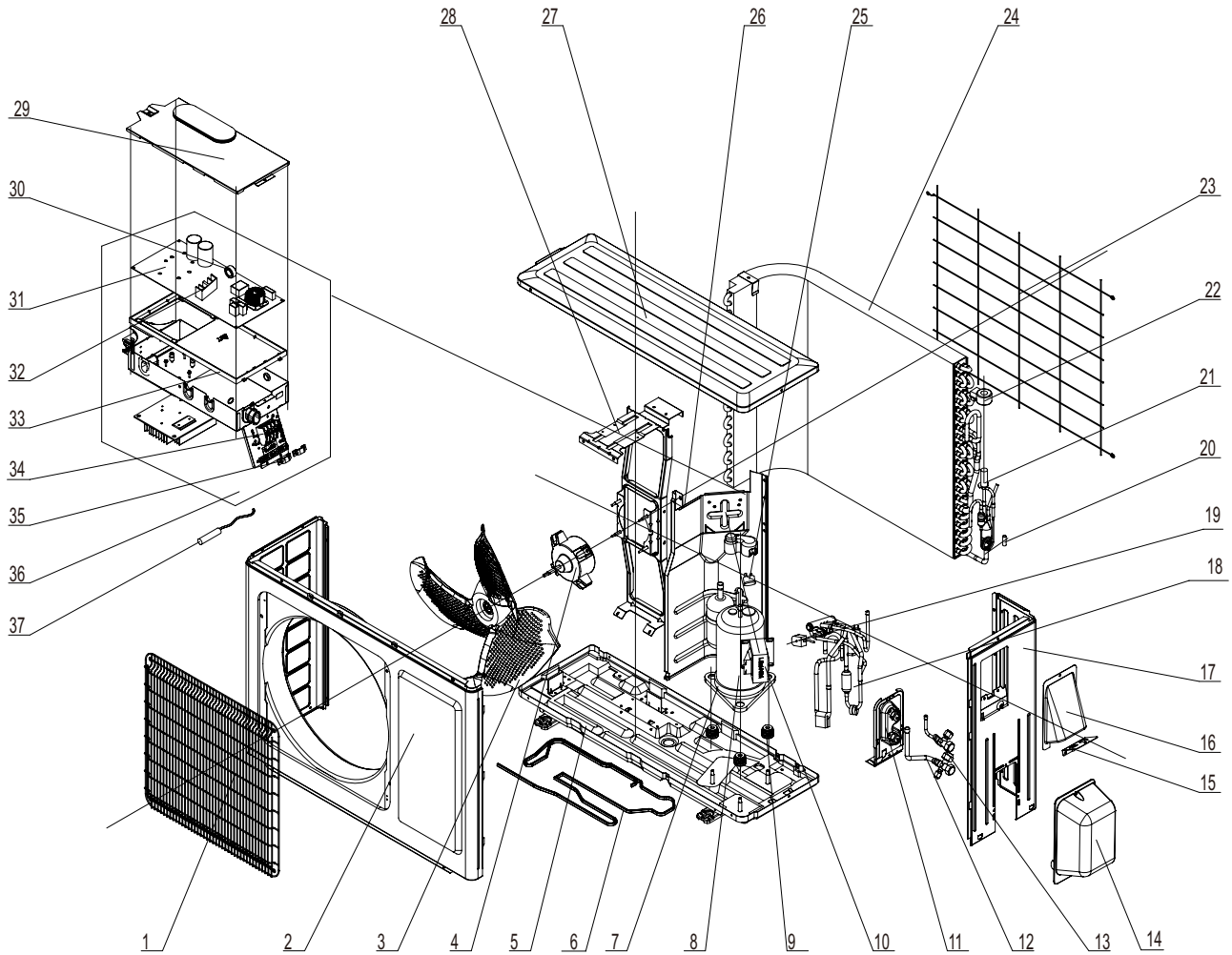

NO.	Description	Part Code		Qty
		GWH12MB-D3DNA3D/O(electric heating belt)		
		CB171W04601		
1	Front Grill	01473012		1
2	Front Panel	0153501201		1
3	Axial Flow Fan	10333012		1
4	Fan Motor	15013159		1
5	Chassis Sub-assy	02803076P		1
6	Electrical Heater (Chassis)	76510004		1
7	Electric Heater(Compressor)	76513004		1
8	Compressor and Fittings	00103851		1
9	Compressor Gasket	76710290		3
10	Reactor	43130185		1
11	Valve Support	01713041		1
12	Valve	07100005		1
13	Valve	07100003		1
14	Valve Cover	22243010		1
15	Cable Cross Plate 1	'02123013P		1
16	Cable Cross Plate 2	'02123014P		1
17	Right Side Plate	0130509901P		1
18	4-Way Valve Assy	03123909		1
19	Magnet Coil	4300040047		1
20	Temp Sensor Sleeving	05212423		1
21	Electric Expansion Valve Sub-Assy	07133676		1
22	Magnet Coil	4300876701		1
23	Rear Grill	01475014		1
24	Condenser Assy	01163459		1
25	Compressor Overload Protector	00183066		1
26	Clapboard Sub-Assy	01233090		1
27	Top Cover Plate	01253443		1
28	Motor Support Spot Welding Sub-assy	0170301002		1
29	Electric Box Cover Sub-Assy	0260309601		1
30	Magnetic Ring	49010104		1
31	Main Board	30148243		1
32	Radiator	49010252		1
33	Electric Box 1	20113005		1
34	Terminal Board	42010313		1
35	Wire Clamp	71010003		2
36	Electric Box Assy	02603910		1
37	Temperature Sensor	39000310		1

The data above are subject to change without notice.

(7)GWC18MC-D3DNA3D/O

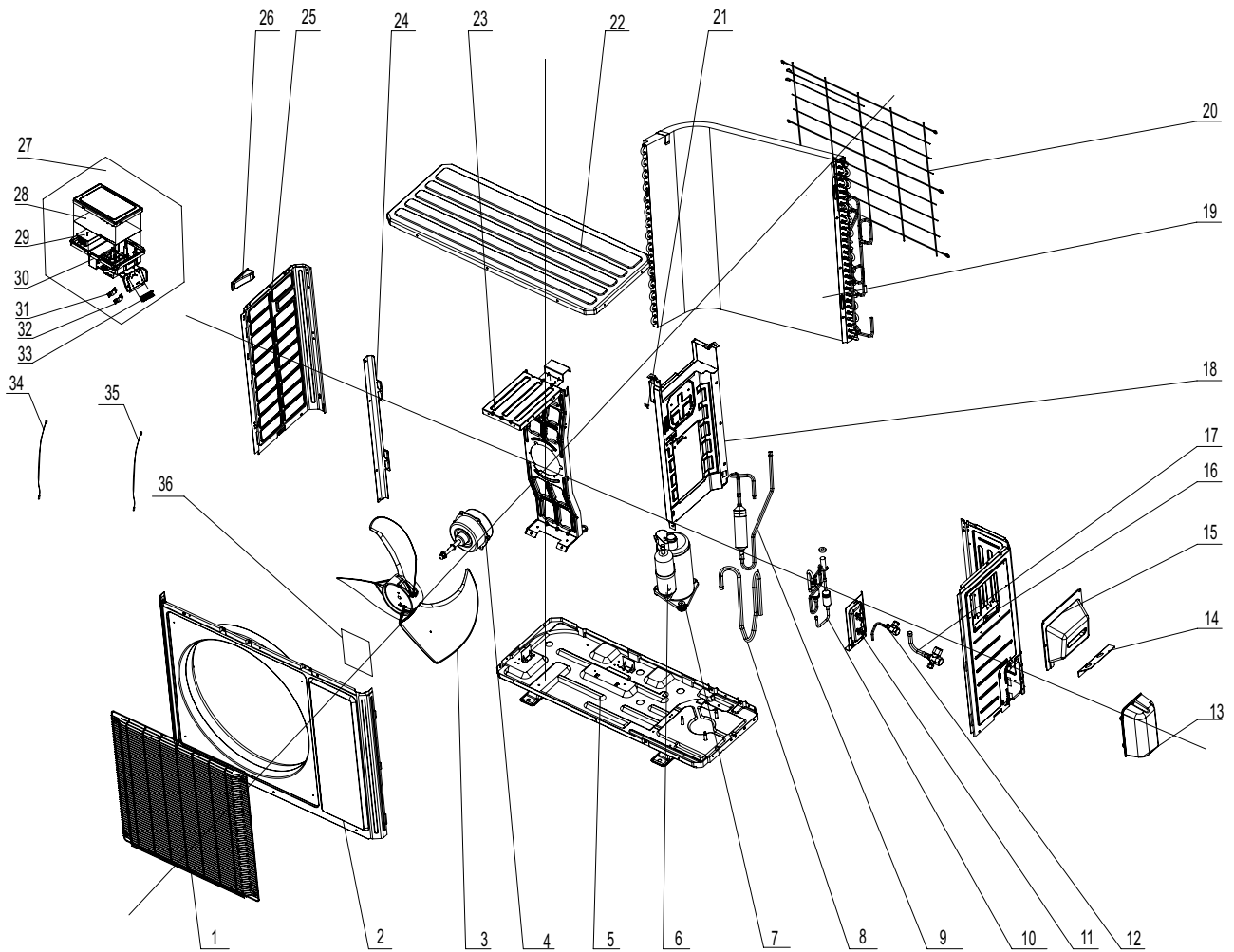

NO.	Description	Part Code		Qty
		GWC18MC-D3DNA3D/O		
		CB171W06800		
1	Rear Grill	01473043		1
2	Cabinet	01433047P		1
3	Axial Flow Fan	10335008		1
4	Fan Motor	1501506402		1
5	Chassis Sub-assy	02803062P		1
6	Compressor and Fittings	00105241		1
7	Compressor Gasket	76715021		3
8	Inhalation Tube	03723930		1
9	Discharge Tube Sub-assy	03833122		1
10	Electric Expansion Valve Sub-Assy	07133681		1
11	Valve Support Assy	01715010P		1
12	Cut off Valve Sub-Assy	07133058		1
13	Valve Cover	22245002		1
14	Retaining Plate	02115006P		1
15	Handle assy	02113109		1
16	Right Side Plate	0130509403P		1
17	Cut off Valve Sub-Assy	07133210		1
18	Clapboard Assy	01233153		1
19	Condenser Assy	01163512		1
20	Front Grill	01473049		1
21	Wiring Clamp	26115004		1
22	Top Cover	01255005P		1
23	Motor Support Sub-Assy	01705036		1
24	Supporting Board(Condenser)	01795010		1
25	Left Side Plate	01305093P		1
26	Left Handle	26235401		1
27	Electric Box Assy	02603938		1
28	Main Board	30148249		1
29	Radiator	49010252		1
30	Electric Box	20113027		1
31	Wire Clamp	71010003		1
32	Wire Clamp	71010003		1
33	Terminal Board	42010255		1
34	Temperature Sensor	39000072		1
35	Temperature Sensor	3900030901		1
36	Insulated Board (Cover of Electric Box)	20113003		1

The data above are subject to change without notice.

(8)GWH18MC-D3DNA3D/O

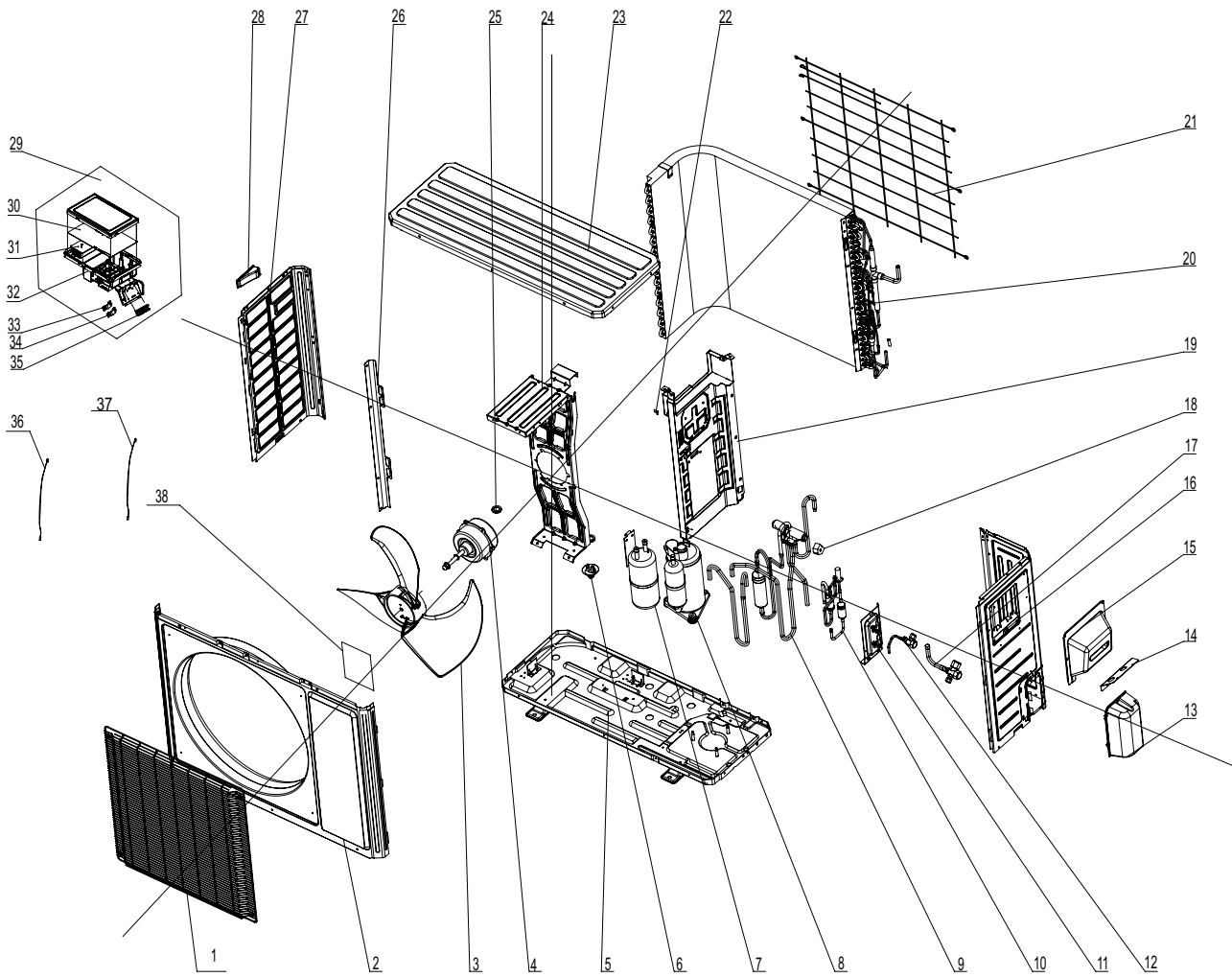

NO.	Description	Part Code		Qty
		GWH18MC-D3DNA3D/O		
		CB171W04700		
1	Rear Grill	01473043		1
2	Cabinet	01433047P		1
3	Axial Flow Fan	10335008		1
4	Fan Motor	1501506402		1
5	Chassis Sub-assy	02803062P		1
6	Drainage Connector	06123401		1
7	Gas-liquid Separator Assy	07225017		1
8	Compressor and Fittings	00105241		1
9	4-Way Valve Assy	03123891		1
10	Electric Expansion Valve Sub-Assy	07133681		1
11	Valve Support Assy	01715010P		1
12	Cut off Valve Sub-Assy	07133058		1
13	Valve Cover	22245002		1
14	Retaining Plate	02115006P		1
15	Handle assy	02113109		1
16	Right Side Plate	0130509403P		1
17	Cut off Valve Sub-Assy	07133210		1
18	Magnet Coil	4300040033		1
19	Clapboard Assy	0123315301		1
20	Condenser Assy	01163487		1
21	Front Grill	01473049		1
22	Wiring Clamp	26115004		1
23	Top Cover	01255005P		1
24	Motor Support Sub-Assy	01705036		1
25	Drainage Plug	06813401		3
26	Supporting Board(Condenser)	01795010		1
27	Left Side Plate	01305093P		1
28	Left Handle	26235401		1
29	Electric Box Assy	02603937		1
30	Main Board	30148250		1
31	Radiator	49010252		1
32	Electric Box	20113027		1
33	Wire Clamp	71010003		1
34	Wire Clamp	71010003		1
35	Terminal Board	42010255		1
36	Temperature Sensor	39000072		1
37	Temperature Sensor	3900030901		1
38	Insulated Board (Cover of Electric Box)	20113003		1

The data above are subject to change without notice.

(9)GWC24MD-D3DNA3D/O

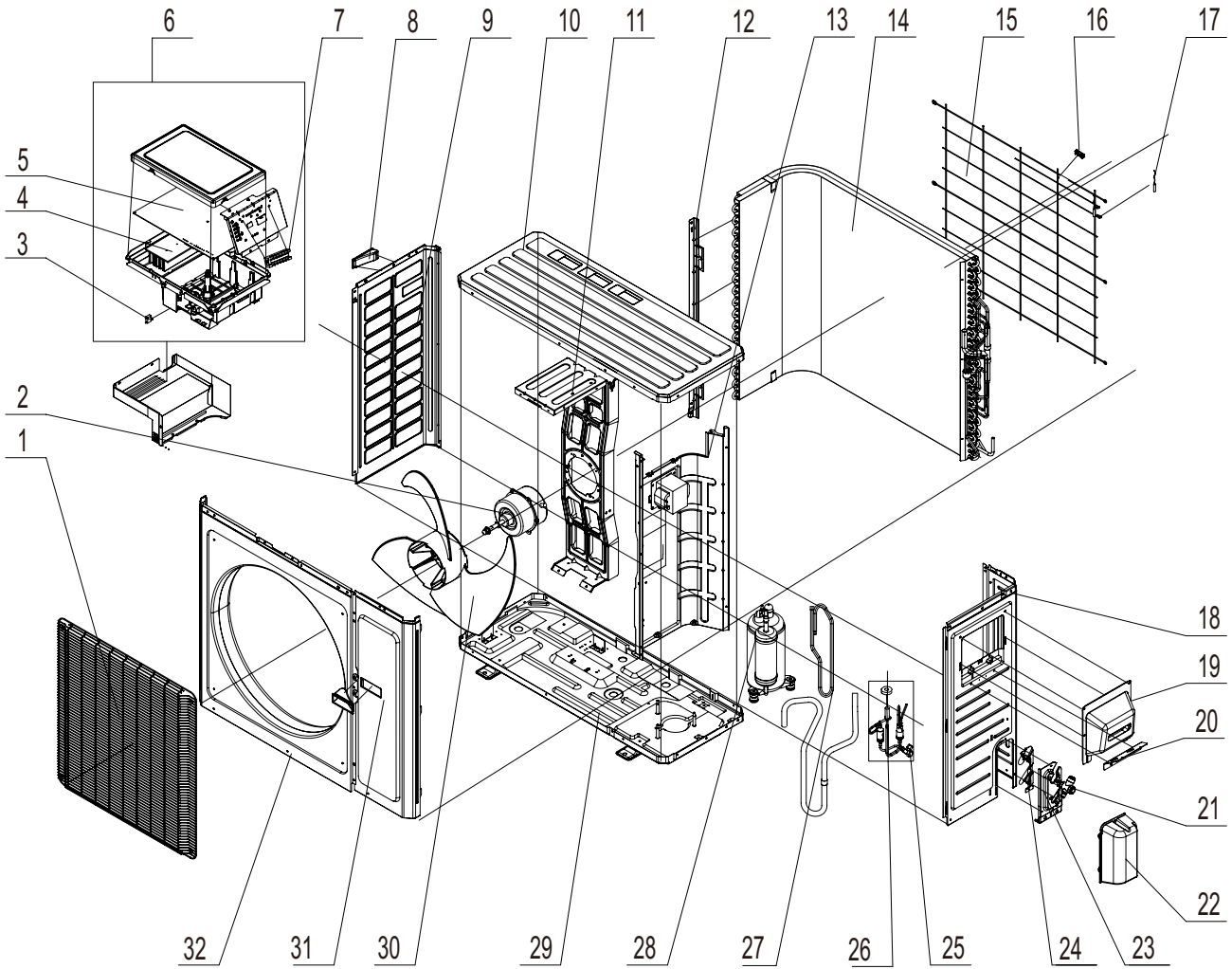

NO.	Description	Part Code		Qty
		GWC24MD-D3DNA3D/O		
		CB171W06900		
1	Front Grill	01473050		1
2	Fan Motor	1501506205		1
3	Capacitor CBB61	33010011		1
4	Radiator	49010252		1
5	Main Board	30148126		1
6	Electric Box Assy	02603940		1
7	Terminal Board	42010255		1
8	Left Handle	26235401		2
9	Left Side Plate	01305043P		1
10	Top Cover	01255006P		1
11	Motor Support Sub-Assy	01705025		1
12	Condenser Support Plate	01175092		1
13	Clapboard Assy	01233154		1
14	Condenser Assy	01163425		1
15	Rear Grill	01475013		1
16	Wiring Clamp	26115004		1
17	Temperature Sensor	39000072		1
18	Right Side Plate	0130504402P		1
19	Handle assy	02113109		1
20	Retaining Plate	02115006P		1
21	Cut off Valve	07133157		1
22	Valve Cover	22245003		1
23	Valve Support Sub-Assy	01715020P		1
24	Baffle(Valve Support)	01365435P		1
25	Cut off Valve	07130239		1
26	Electric Expand Valve Fitting	4300876705		1
27	Discharge Tube Sub-assy	03833031		1
28	Compressor and Fittings	00103873		1
29	Chassis Sub-assy	02803080P		1
30	Axial Flow Fan	10335005		1
31	Front Side Plate	01305086P		1
32	Cabinet	0143500401P		1

The data above are subject to change without notice.

(10)GWH24MD-D3DNA3D/O

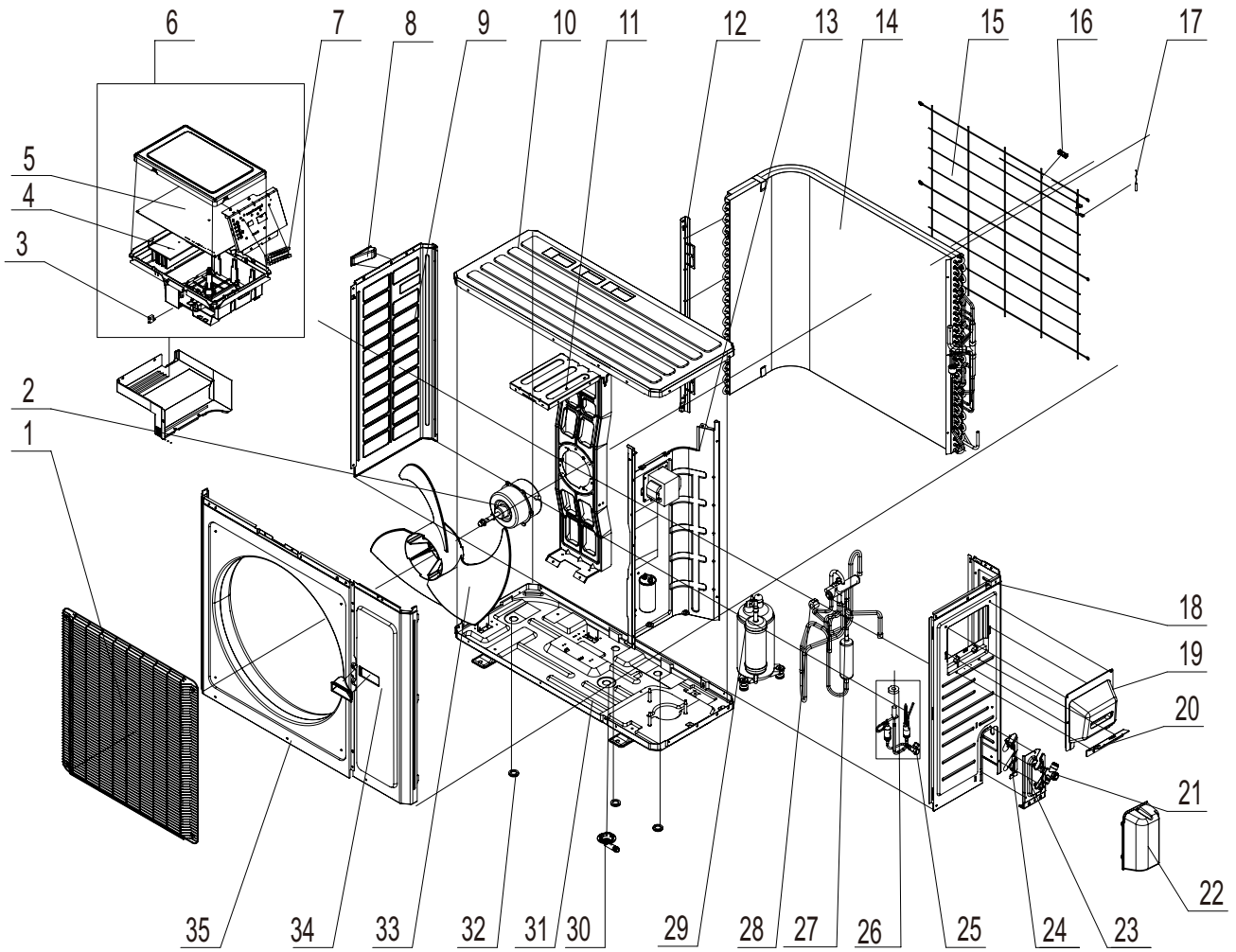

NO.	Description	Part Code		Qty
		GWH24MD-D3DNA3D/O		
		CB171W07000		
1	Front Grill	01473050	1	
2	Fan Motor	1501506205	1	
3	Capacitor CBB61	33010011	1	
4	Radiator	4901302801	1	
5	Main Board	30148256	1	
6	Electric Box Assy	02603939	1	
7	Terminal Board	42010255	1	
8	Left Handle	26235401	2	
9	Left Side Plate	01305043P	1	
10	Top Cover	01255006P	1	
11	Motor Support Sub-Assy	01705025	1	
12	Condenser Support Plate	01175092	1	
13	Clapboard Assy	01233154	1	
14	Condenser Assy	01163427	1	
15	Rear Grill	01475013	1	
16	Wiring Clamp	26115004	1	
17	Temperature Sensor	39000072	1	
18	Right Side Plate	0130504402P	1	
19	Handle assy	02113109	1	
20	Retaining Plate	02115006P	1	
21	Cut off Valve	07133157	1	
22	Valve Cover	22245003	1	
23	Valve Support Sub-Assy	01715020P	1	
24	Baffle(Valve Support)	01365435P	1	
25	Cut off Valve Sub-Assy	07135072	1	
26	Electric Expand Valve Fitting	4300876705	1	
27	4-Way Valve Assy	03123863	1	
28	Magnet Coil	4300040045	1	
29	Compressor and Fittings	00103873	1	
30	Drainage Connector	06123401	1	
31	Chassis Sub-assy	02803080P	1	
32	Drainage Plug	06813401	3	
33	Axial Flow Fan	10335005	1	
34	Front Side Plate	01305086P	1	
35	Cabinet	0143500401P	1	

The data above are subject to change without notice.

(11)GWH18MC-D3DNA3D/O(electric heating band)

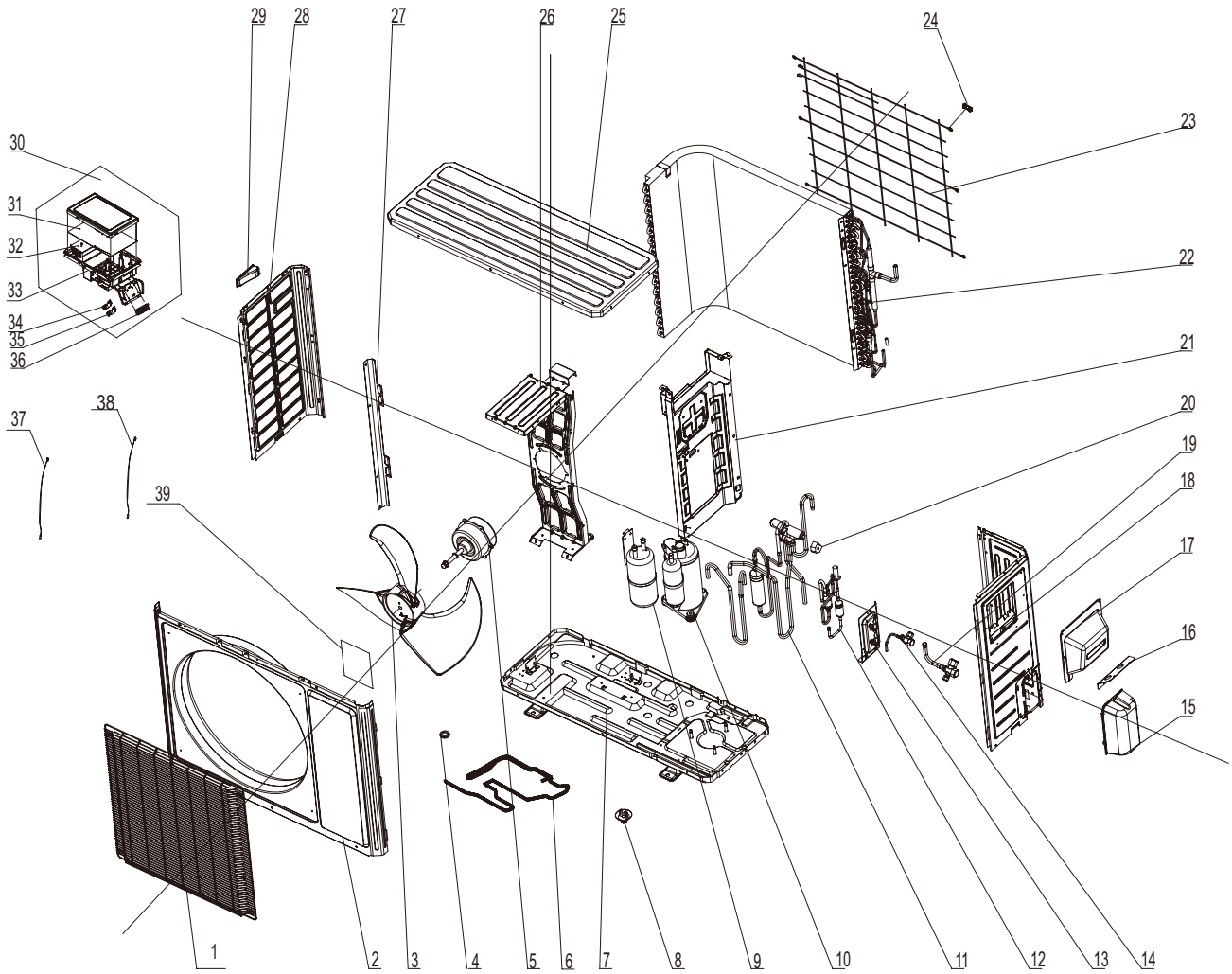

NO.	Description	Part Code	Qty
		GWH18MC-D3DNA3D/O(electric heating band)	
	Product Code	CB171W04701	
1	Front Grill	01473049	1
2	Cabinet	01433047P	1
3	Axial Flow Fan	10335008	1
4	Drainage Plug	06813401	3
5	Fan Motor	1501506402	1
6	Electrical Heater (Chassis)	765100045	1
7	Chassis Sub-assy	02803083P	1
8	Drainage Connector	06123401	1
9	Gas-liquid Separator Assy	07225017	1
10	Compressor and Fittings	00105241	1
11	4-Way Valve Assy	03123891	1
12	Electric Expansion Valve Sub-Assy	07133681	1
13	Valve Support Assy	01715010P	1
14	Cut off Valve Sub-Assy	07133210	1
15	Valve Cover	22245002	1
16	Retaining Plate	02115006P	1
17	Handle assy	02113109	1
18	Right Side Plate	0130509403P	1
19	Cut off Valve Sub-Assy	07133058	1
20	Magnet Coil	4300040033	1
21	Clapboard Assy	0123315301	1
22	Condenser Assy	01163487	1
23	Rear Grill	01473043	1
24	Wiring Clamp	26115004	1
25	Top Cover	01255005P	1
26	Motor Support Sub-Assy	01705036	1
27	Supporting Board(Condenser)	01795010	1
28	Left Side Plate	01305093P	1
29	Left Handle	26235401	1
30	Electric Box Assy	0260393702	1
31	Main Board	30148496	1
32	Radiator	49010252	1
33	Electric Box	20113027	1
34	Wire Clamp	71010003	1
35	Wire Clamp	71010003	1
36	Terminal Board	42010255	1
37	Temperature Sensor	39000072	1
38	Temperature Sensor	39000072	1
39	Insulated Board (Cover of Electric Box)	20113003	1

The data above are subject to change without notice.

(12)GWH24MD-D3DNA3D/O(electric heating band)

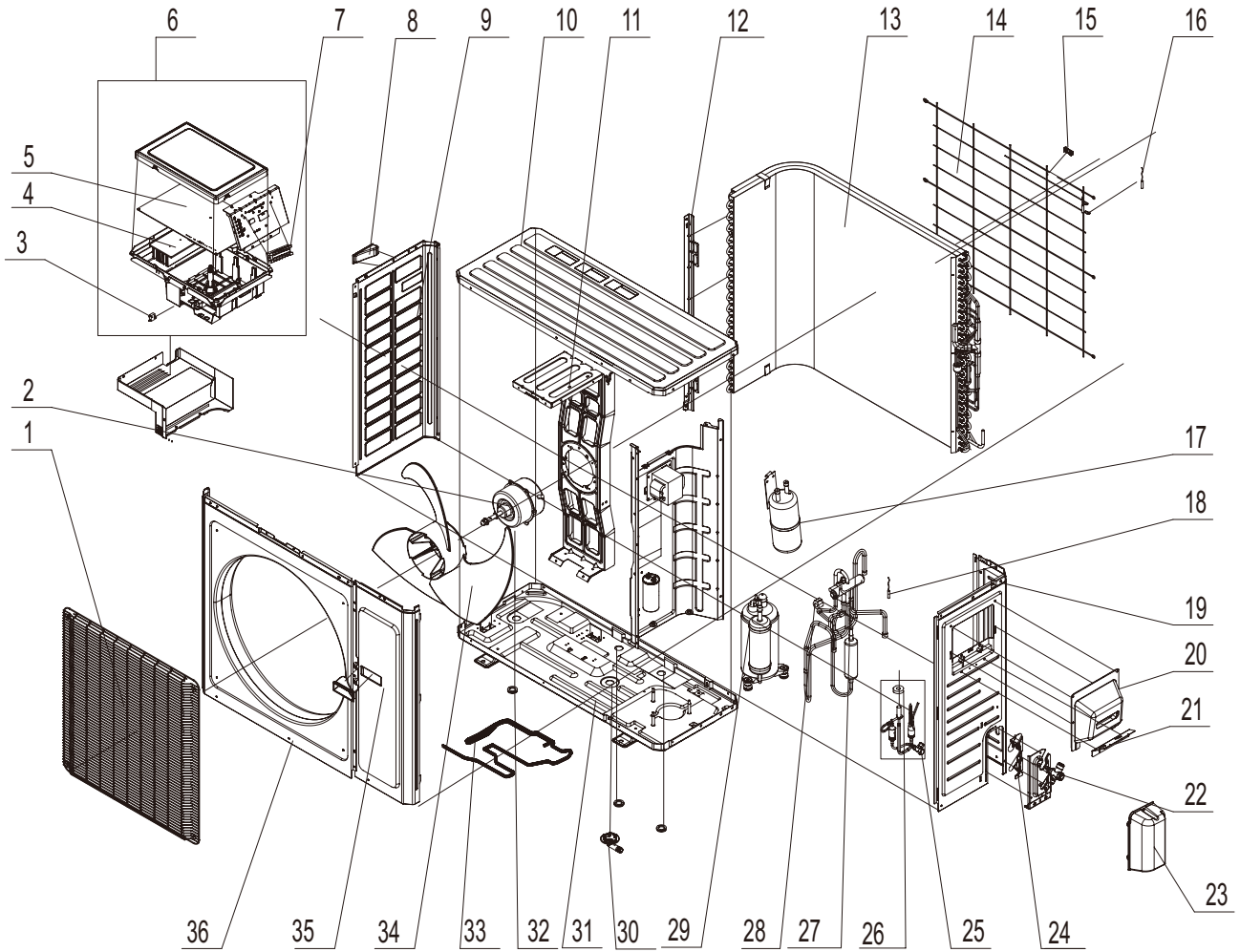

NO.	Description	Part Code		Qty
		GWH24MD-D3DNA3D/O(electric heating band)		
		CB171W07001		
1	Front Grill	01473050		1
2	Fan Motor	1501506205		1
3	Capacitor CBB61	33010011		1
4	Radiator	49010252		1
5	Main Board	30148498		1
6	Electric Box Assy	02613295		1
7	Terminal Board	42010255		1
8	Left Handle	26235401		2
9	Left Side Plate	01305043P		1
10	Top Cover	01255006P		1
11	Motor Support Sub-Assy	01705025		1
12	Condenser Support Plate	01175092		1
13	Condenser Assy	01163427		1
14	Rear Grill	01475013		1
15	Wiring Clamp	26115004		1
16	Temperature Sensor	39000072		1
17	Gas-liquid Separator Assy	07225017		1
18	Temperature Sensor	39000072		1
19	Right Side Plate	0130504402P		1
20	Handle assy	02113109		1
21	Retaining Plate	02115006P		1
22	Cut off Valve	07133157		1
23	Valve Cover	22245003		1
24	Baffle(Valve Support)	01365435P		1
25	Cut off Valve Sub-Assy	07135072		1
26	Electric Expand Valve Fitting	4300876705		1
27	4-Way Valve Assy	03123863		1
28	Magnet Coil	4300040045		1
29	Compressor and Fittings	00103873		1
30	Drainage Connector	06123401		1
31	Chassis Sub-assy	0280308001P		1
32	Drainage Plug	06813401		3
33	Electrical Heater (Chassis)	7651000411		1
34	Axial Flow Fan	10335005		1
35	Front Side Plate Sub-Assy	01303249P		1
36	Cabinet	0143500401P		1

The data above are subject to change without notice.

9. Troubleshooting

9.1 Malfunction Analysis

Note: When replacing the controller, make sure insert the wire jumper into the new controller, otherwise the unit will display C5

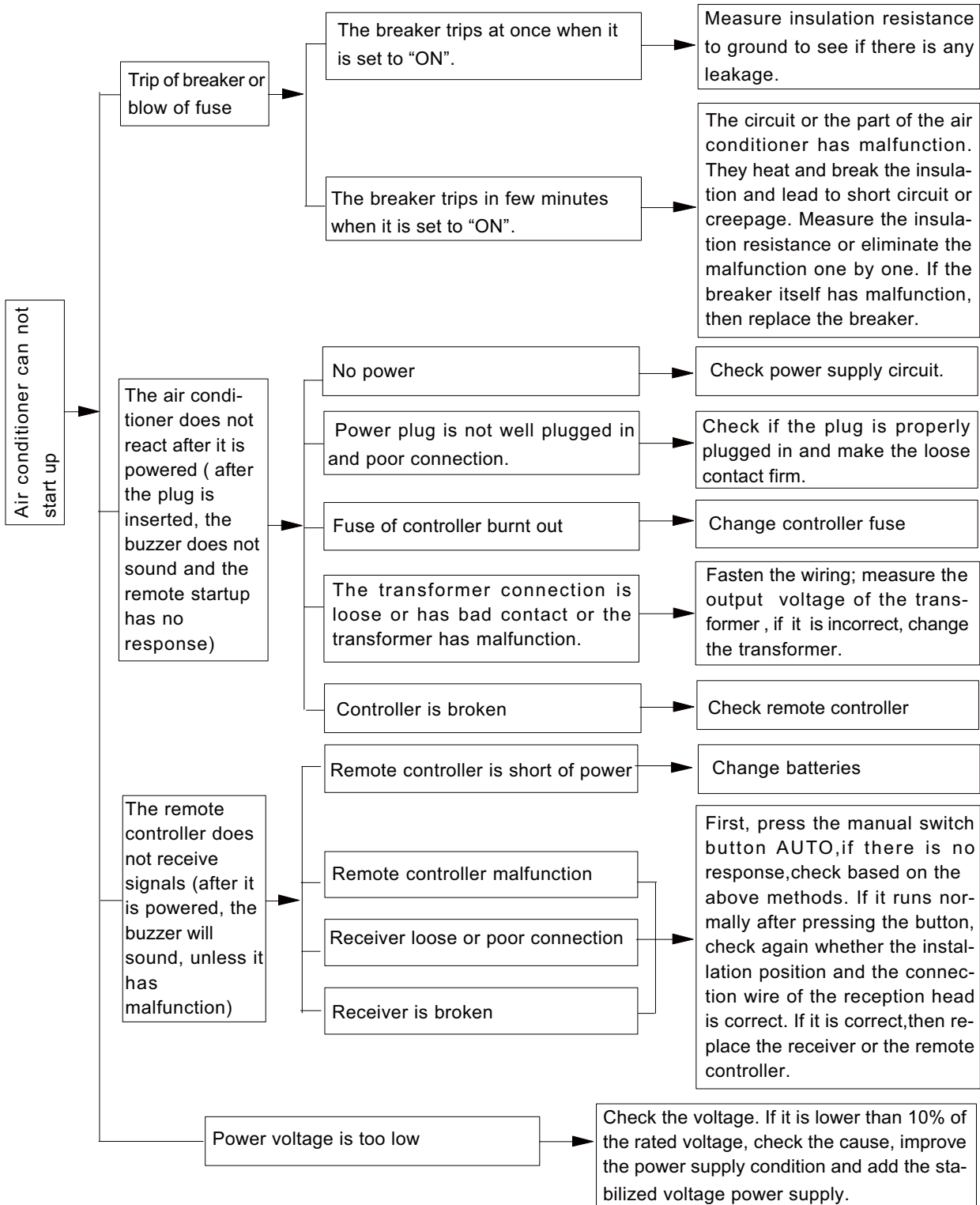

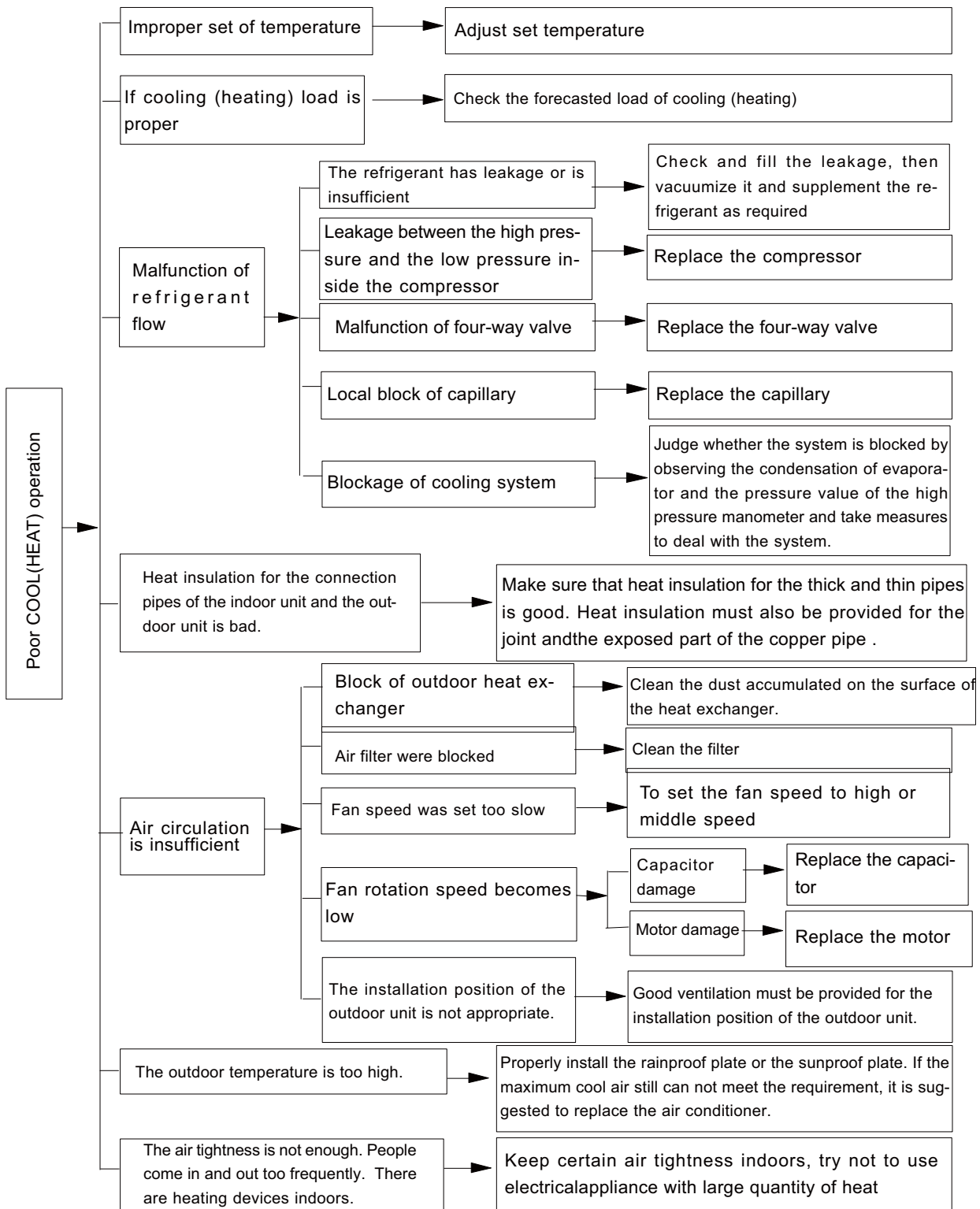

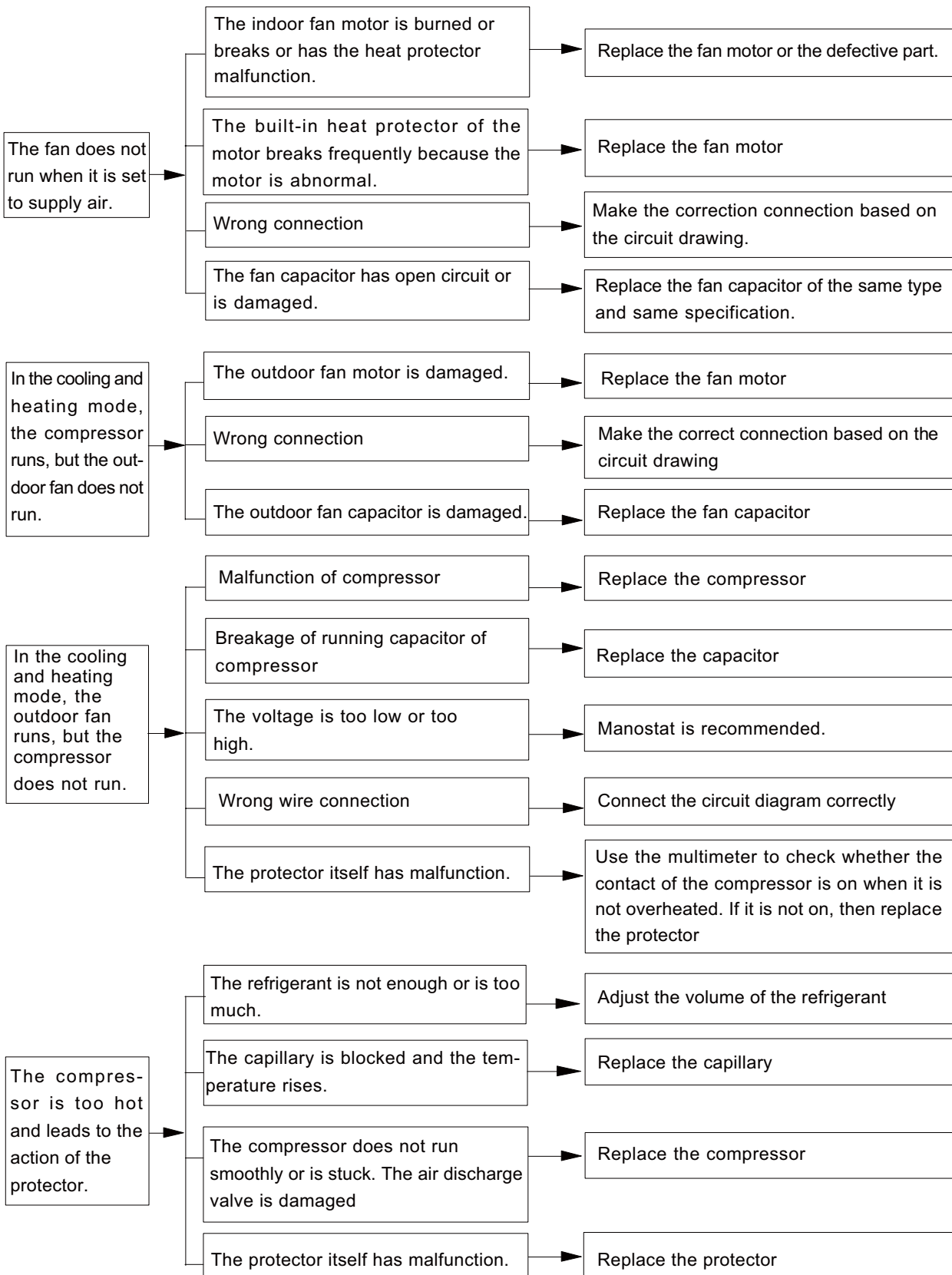

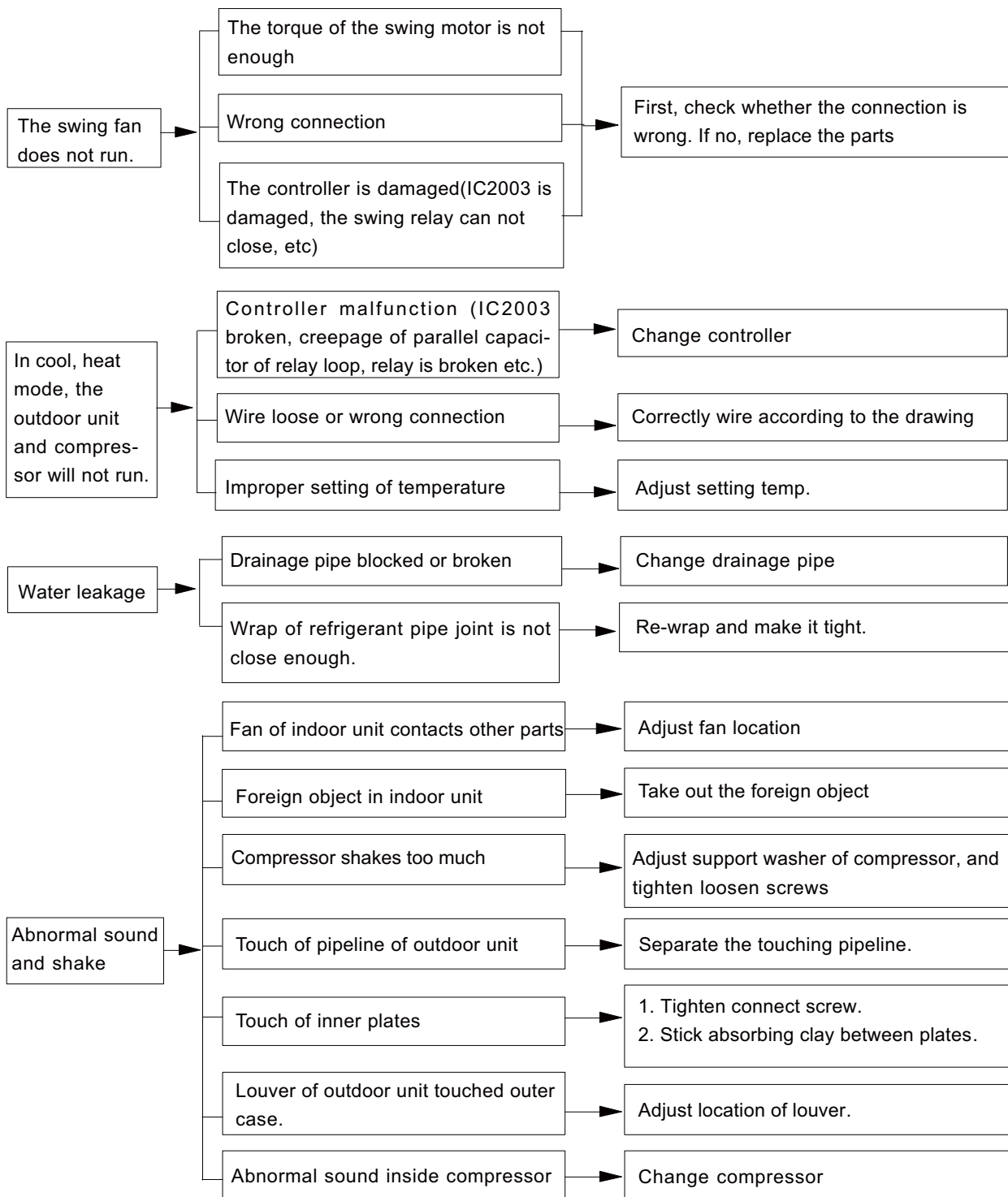

9.2 Flashing LED of Indoor/Outdoor Unit and Primary Judgement

Applicable for 09 & 12K model

NO.	Malfunction Name	Display Method of Indoor Unit			Display Method of Outdoor Unit			A/C status	Possible Causes	
		Dual-8 Code Display	Indicator Display (during blinking, ON 0.5s and OFF 0.5s)			Indicator has 3 kinds of display status and during blinking, ON 0.5s and OFF 0.5s				
			Operation Indicator	Cool Indicator	Heating Indicator	Yellow Indicator	Red Indicator			Green Indicator
1	High pressure protection of system	E1	OFF 3s and blink once						During cooling and drying operation, except indoor fan operates, all loads stop operation. During heating operation, the complete unit stops.	Possible reasons: 1. Refrigerant was superabundant; 2. Poor heat exchange (including filth blockage of heat exchanger and bad radiating environment); Ambient temperature is too high.
2	Antifreezing protection	E2	OFF 3S and blink twice				OFF 3S and blink 3 times		During cooling and drying operation, compressor and outdoor fan stop while indoor fan operates.	1. Poor air-return in indoor unit; 2. Fan speed is abnormal; 3. Evaporator is dirty.
3	System block or refrigerant leakage	E3	OFF 3S and blink 3 times					OFF 3S and blink 9 times	The Dual-8 Code Display will show E3 until the low pressure switch stop operation.	1.Low-pressure protection 2.Low-pressure protection of system 3.Low-pressure protection of compressor
4	High discharge temperature protection of compressor	E4	OFF 3S and blink 4 times				OFF 3S and blink 7 times		During cooling and drying operation, compressor and outdoor fan stop while indoor fan operates. During heating operation, all loads stop.	Please refer to the malfunction analysis (discharge protection, overload).
5	Overcurrent protection	E5	OFF 3S and blink 5 times				OFF 3S and blink 5 times		During cooling and drying operation, compressor and outdoor fan stop while indoor fan operates. During heating operation, all loads stop.	1. Supply voltage is unstable; 2. Supply voltage is too low and load is too high; 3. Evaporator is dirty.
6	Communication Malfunction	E6	OFF 3S and blink 6 times					OFF	During cooling operation, compressor stops while indoor fan motor operates. During heating operation, the complete unit stops.	Refer to the corresponding malfunction analysis.
7	High temperature resistant protection	E8	OFF 3S and blink 8 times				OFF 3S and blink 6 times		During cooling operation: compressor will stop while indoor fan will operate. During heating operation, the complete unit stops.	Refer to the malfunction analysis (overload, high temperature resistant).
8	EEPROM malfunction	EE			OFF 3S and blink 15 times		OFF 3S and blink 11 times		During cooling and drying operation, compressor will stop while indoor fan will operate; During heating operation, the complete unit will stop	Replace outdoor control panel AP1
9	Limit/decrease frequency due to high temperature of module	EU		OFF 3S and blink 6 times		OFF 3S and blink 6 times			All loads operate normally, while operation frequency for compressor is decreased	Discharging after the complete unit is de-energized for 20mins, check whether the thermal grease on IPM Module of outdoor control panel AP1 is sufficient and whether the radiator is inserted tightly. If its no use, please replace control panel AP1.
10	Malfunction protection of jumper cap	C5	OFF 3S and blink 15 times						Wireless remote receiver and button are effective, but can not dispose the related command	1. No jumper cap insert on mainboard. 2. Incorrect insert of jumper cap. 3. Jumper cap damaged. 4. Abnormal detecting circuit of mainboard.

NO.	Malfunction Name	Display Method of Indoor Unit			Display Method of Outdoor Unit			A/C status	Possible Causes	
		Dual-8 Code Display	Indicator Display (during blinking, ON 0.5s and OFF 0.5s)			Indicator has 3 kinds of display status and during blinking, ON 0.5s and OFF 0.5s				
			Operation Indicator	Cool Indicator	Heating Indicator	Yellow Indicator	Red Indicator			Green Indicator
11	Gathering refrigerant	F0	OFF 3S and blink 1 times	OFF 3S and blink 1 times				When the outdoor unit receive signal of Gathering refrigerant ,the system will be forced to run under cooling mode for gathering refrigerant	Nominal cooling mode	
12	Indoor ambient temperature sensor is open/short circuited	F1		OFF 3S and blink once				During cooling and drying operation, indoor unit operates while other loads will stop; during heating operation, the complete unit will stop operation.	1. Loosening or bad contact of indoor ambient temp. sensor and mainboard terminal. 2. Components in mainboard fell down leads short circuit. 3. Indoor ambient temp. sensor damaged.(check with sensor resistance value chart) 4. Mainboard damaged.	
13	Indoor evaporator temperature sensor is open/short circuited	F2		OFF 3S and blink twice				AC stops operation once reaches the setting temperature. Cooling, drying: internal fan motor stops operation while other loads stop operation; heating: AC stop operation	1. Loosening or bad contact of Indoor evaporator temp. sensor and mainboard terminal. 2. Components on the mainboard fall down leads short circuit. 3. Indoor evaporator temp. sensor damaged.(check temp. sensor value chart for testing) 4. Mainboard damaged.	
14	Outdoor ambient temperature sensor is open/short circuited	F3		OFF 3S and blink 3 times			OFF 3S and blink 6 times	During cooling and drying operating, compressor stops while indoor fan operates; During heating operation, the complete unit will stop operation	Outdoor temperature sensor hasnt been connected well or is damaged. Please check it by referring to the resistance table for temperature sensor)	
15	Outdoor condenser temperature sensor is open/short circuited	F4		OFF 3S and blink 4 times			OFF 3S and blink 5 times	During cooling and drying operation, compressor stops while indoor fan will operate; During heating operation, the complete unit will stop operation.	Outdoor temperature sensor hasnt been connected well or is damaged. Please check it by referring to the resistance table for temperature sensor)	
16	Outdoor discharge temperature sensor is open/short circuited	F5		OFF 3S and blink 5 times			OFF 3S and blink 7 times	During cooling and drying operation, compressor will sop after operating for about 3 mins, while indoor fan will operate; During heating operation, the complete unit will stop after operating for about 3 mins.	1.Outdoor temperature sensor hasnt been connected well or is damaged. Please check it by referring to the resistance table for temperature sensor) 2.The head of temperature sensor hasnt been inserted into the copper tube	
17	Limit/decrease frequency due to overload	F6		OFF 3S and blink for 6 times			OFF 3S and blink 3 times	All loads operate normally, while operation frequency for compressor is decreased	Refer to the malfunction analysis (overload, high temperature resistant)	
18	Decrease frequency due to overcurrent	F8		OFF 3S and blink 8 times			OFF 3S and blink once	All loads operate normally, while operation frequency for compressor is decreased	The input supply voltage is too low; System pressure is too high and overload	

Troubleshooting

NO.	Malfunction Name	Display Method of Indoor Unit			Display Method of Outdoor Unit			A/C status	Possible Causes	
		Dual-8 Code Display	Indicator Display (during blinking, ON 0.5s and OFF 0.5s)			Indicator has 3 kinds of display status and during blinking, ON 0.5s and OFF 0.5s				
			Operation Indicator	Cool Indicator	Heating Indicator	Yellow Indicator	Red Indicator			Green Indicator
19	Decrease frequency due to high air discharge	F9		OFF 3S and blink 9 times				OFF 3S and blink twice	All loads operate normally, while operation frequency for compressor is decreased	Overload or temperature is too high; Refrigerant is insufficient; Malfunction of electric expansion valve (EKV)
20	Limit/decrease frequency due to antifreezing	FH		OFF 3S and blink 2 times	OFF 3S and blink 2 times			OFF 3S and blink 4 times	All loads operate normally, while operation frequency for compressor is decreased	Poor air-return in indoor unit or fan speed is too low
21	Voltage for DC bus-bar is too high	PH		OFF 3S and blink 11 times				OFF 3S and blink 13 times	During cooling and drying operation, compressor will stop while indoor fan will operate; During heating operation, the complete unit will stop operation.	1. Measure the voltage of position L and N on wiring board (XT), if the voltage is higher than 265VAC, turn on the unit after the supply voltage is increased to the normal range. 2.If the AC input is normal, measure the voltage of electrolytic capacitor C on control panel (AP1), if its normal, theres malfunction for the circuit, please replace the control panel (AP1)
22	Voltage of DC bus-bar is too low	PL			OFF 3S and blink 21 times			OFF 3S and blink 12 times	During cooling and drying operation, compressor will stop while indoor fan will operate; During heating operation, the complete unit will stop	1. Measure the voltage of position L and N on wiring board (XT), if the voltage is higher than 150VAC, turn on the unit after the supply voltage is increased to the normal range. 2.If the AC input is normal, measure the voltage of electrolytic capacitor C on control panel (AP1), if its normal, theres malfunction for the circuit, please replace the control panel (AP1)
23	Compressor Min frequency in test state	P0		(during blinking, ON 0.25s and OFF 0.25s)	(during blinking, ON 0.25s and OFF 0.25s)					Showing during min. cooling or min. heating test
24	Compressor rated frequency in test state	P1		(during blinking, ON 0.25s and OFF 0.25s)	(during blinking, ON 0.25s and OFF 0.25s)					Showing during nominal cooling or nominal heating test
25	Compressor maximum frequency in test state	P2		(during blinking, ON 0.25s and OFF 0.25s)	(during blinking, ON 0.25s and OFF 0.25s)					Showing during max. cooling or max. heating test

NO.	Malfunction Name	Display Method of Indoor Unit			Display Method of Outdoor Unit			A/C status	Possible Causes	
		Dual-8 Code Display	Indicator Display (during blinking, ON 0.5s and OFF 0.5s)			Indicator has 3 kinds of display status and during blinking, ON 0.5s and OFF 0.5s				
			Operation Indicator	Cool Indicator	Heating Indicator	Yellow Indicator	Red Indicator			Green Indicator
26	Compressor intermediate frequency in test state	P3		(during blinking, ON 0.25s and OFF 0.25s)	(during blinking, ON 0.25s and OFF 0.25s)				Showing during middle cooling or middle heating test	
27	Overcurrent protection of phase current for compressor	P5		OFF 3S and blink 15 times				During cooling and drying operation, compressor will stop while indoor fan will operate; During heating operation, the complete unit will stop operation.	Refer to the malfunction analysis (IPM protection, loss of synchronism protection and overcurrent protection of phase current for compressor.	
28	Charging malfunction of capacitor	PU			OFF 3S and blink 17 times			During cooling and drying operation, compressor will stop while indoor fan will operate; During heating operation, the complete unit will stop	Refer to the part three—charging malfunction analysis of capacitor	
29	Malfunction of module temperature sensor circuit	P7			OFF 3S and blink 18 times			During cooling and drying operation, compressor will stop while indoor fan will operate; During heating operation, the complete unit will stop	Replace outdoor control panel AP1	
30	Module high temperature protection	P8			OFF 3S and blink 19 times			During cooling operation, compressor will stop while indoor fan will operate; During heating operation, the complete unit will stop	After the complete unit is de-energized for 20mins, check whether the thermal grease on IPM Module of outdoor control panel AP1 is sufficient and whether the radiator is inserted tightly. If its no use, please replace control panel AP1.	
31	Decrease frequency due to high temperature resistant during heating operation	H0			OFF 3S and blink 10 times			All loads operate normally, while operation frequency for compressor is decreased	Refer to the malfunction analysis (overload, high temperature resistant)	
32	Static dedusting protection	H2			OFF 3S and blink twice					
33	Overload protection for compressor	H3			OFF 3S and blink 3 times	OFF 3S and blink 8 times		During cooling and drying operation, compressor will stop while indoor fan will operate; During heating operation, the complete unit will stop operation.	1. Wiring terminal OVC-COMP is loosened. In normal state, the resistance for this terminal should be less than 1ohm. 2. Refer to the malfunction analysis (discharge protection, overload)	

Troubleshooting

NO.	Malfunction Name	Display Method of Indoor Unit			Display Method of Outdoor Unit			A/C status	Possible Causes	
		Dual-8 Code Display	Indicator Display (during blinking, ON 0.5s and OFF 0.5s)			Indicator has 3 kinds of display status and during blinking, ON 0.5s and OFF 0.5s				
			Operation Indicator	Cool Indicator	Heating Indicator	Yellow Indicator	Red Indicator			Green Indicator
34	System is abnormal	H4			OFF 3S and blink 4 times	OFF 3S and blink 6 times			During cooling and drying operation, compressor will stop while indoor fan will operate; During heating operation, the complete unit will stop operation.	Refer to the malfunction analysis (overload, high temperature resistant)
35	IPM protection	H5			OFF 3S and blink 5 times	OFF 3S and blink 4 times			During cooling and drying operation, compressor will stop while indoor fan will operate; During heating operation, the complete unit will stop operation.	Refer to the malfunction analysis (IPM protection, loss of synchronism protection and overcurrent protection of phase current for compressor.
36	Module temperature is too high	H5			OFF 3S and blink 5 times	OFF 3S and blink 10 times				
37	Internal motor (fan motor) do not operate	H6	OFF 3S and blink 11 times						Internal fan motor, external fan motor, compressor and electric heater stop operation,guide louver stops at present location.	1. Bad contact of DC motor feedback terminal. 2. Bad contact of DC motor control end. 3. Fan motor is stalling. 4. Motor malfunction. 5. Malfunction of mainboard rev detecting circuit.
38	Desynchronizing of compressor	H7			OFF 3S and blink 7 times				During cooling and drying operation, compressor will stop while indoor fan will operate; During heating operation, the complete unit will stop operation.	Refer to the malfunction analysis (IPM protection, loss of synchronism protection and overcurrent protection of phase current for compressor.
39	PFC protection	HC			OFF 3S and blink 6 times	OFF 3S and blink 14 times			During cooling and drying operation, compressor will stop while indoor fan will operate; During heating operation, the complete unit will stop operation.	Refer to the malfunction analysis
40	Outdoor DC fan motor malfunction	L3	OFF 3S and blink 23 times				OFF 3S and blink 14 times		Outdoor DC fan motor malfunction lead to compressor stop operation,	DC fan motor malfunction or system blocked or the connector loosed
41	power protection	L9	OFF 3S and blink 20 times				OFF 3S and blink 9 times		compressor stop operation and Outdoor fan motor will stop 30s latter , 3 minutes latter fan motor and compressor will restart	To protect the electrical components when detect high power
42	Indoor unit and outdoor unit doesn't match	LP	OFF 3S and blink 19 times				OFF 3S and blink 16 times		compressor and Outdoor fan motor can't work	Indoor unit and outdoor unit doesn't match
43	Failure start-up	LC			OFF 3S and blink 11 times				During cooling and drying operation, compressor will stop while indoor fan will operate; During heating operation, the complete unit will stop operation.	Refer to the malfunction analysis

NO.	Malfunction Name	Display Method of Indoor Unit			Display Method of Outdoor Unit			A/C status	Possible Causes	
		Dual-8 Code Display	Indicator Display (during blinking, ON 0.5s and OFF 0.5s)			Indicator has 3 kinds of display status and during blinking, ON 0.5s and OFF 0.5s				
			Operation Indicator	Cool Indicator	Heating Indicator	Yellow Indicator	Red Indicator			Green Indicator
44	Malfunction of phase current detection circuit for compressor	U1			OFF 3S and blink 13 times				During cooling and drying operation, compressor will stop while indoor fan will operate; During heating operation, the complete unit will stop	Replace outdoor control panel AP1
45	Malfunction of voltage dropping for DC bus-bar	U3			OFF 3S and blink 20 times				During cooling and drying operation, compressor will stop while indoor fan will operate; During heating operation, the complete unit will stop	Supply voltage is unstable
46	Malfunction of complete units current detection	U5		OFF 3S and blink 13 times					During cooling and drying operation, the compressor will stop while indoor fan will operate; During heating operating, the complete unit will stop operation.	Theres circuit malfunction on outdoor units control panel AP1, please replace the outdoor units control panel AP1.
47	The four-way valve is abnormal	U7		OFF 3S and blink 20 times					If this malfunction occurs during heating operation, the complete unit will stop operation.	1.Supply voltage is lower than AC175V; 2.Wiring terminal 4V is loosened or broken; 3.4V is damaged, please replace 4V.
48	Zero-crossing malfunction of outdoor unit	U9	OFF 3S and blink 18 times						During cooling operation, compressor will stop while indoor fan will operate; during heating,the complete unit will stop operation.	Replace outdoor control panel AP1
49	Frequency limiting (power)						OFF 3S and blink 13 times			
50	Compressor is open-circuited					OFF 3S and blink once				
51	The temperature for turning on the unit is reached						OFF 3S and blink 8 times			
52	Frequency limiting (module temperature)						OFF 3S and blink 11 times			

NO.	Malfunction Name	Display Method of Indoor Unit			Display Method of Outdoor Unit			A/C status	Possible Causes	
		Dual-8 Code Display	Indicator Display (during blinking, ON 0.5s and OFF 0.5s)			Indicator has 3 kinds of display status and during blinking, ON 0.5s and OFF 0.5s				
			Operation Indicator	Cool Indicator	Heating Indicator	Yellow Indicator	Red Indicator	Green Indicator		
53	Normal communication							continuously		
54	Defrosting				OFF 3S and blink once (during blinking, ON 10s and OFF 0.5s)	OFF 3S and blink twice			Defrosting will occur in heating mode. Compressor will operate while indoor fan will stop operation.	Its the normal state

If malfunction occurs, corresponding code will display and the unit will resume normal until protection or malfunction disappears.

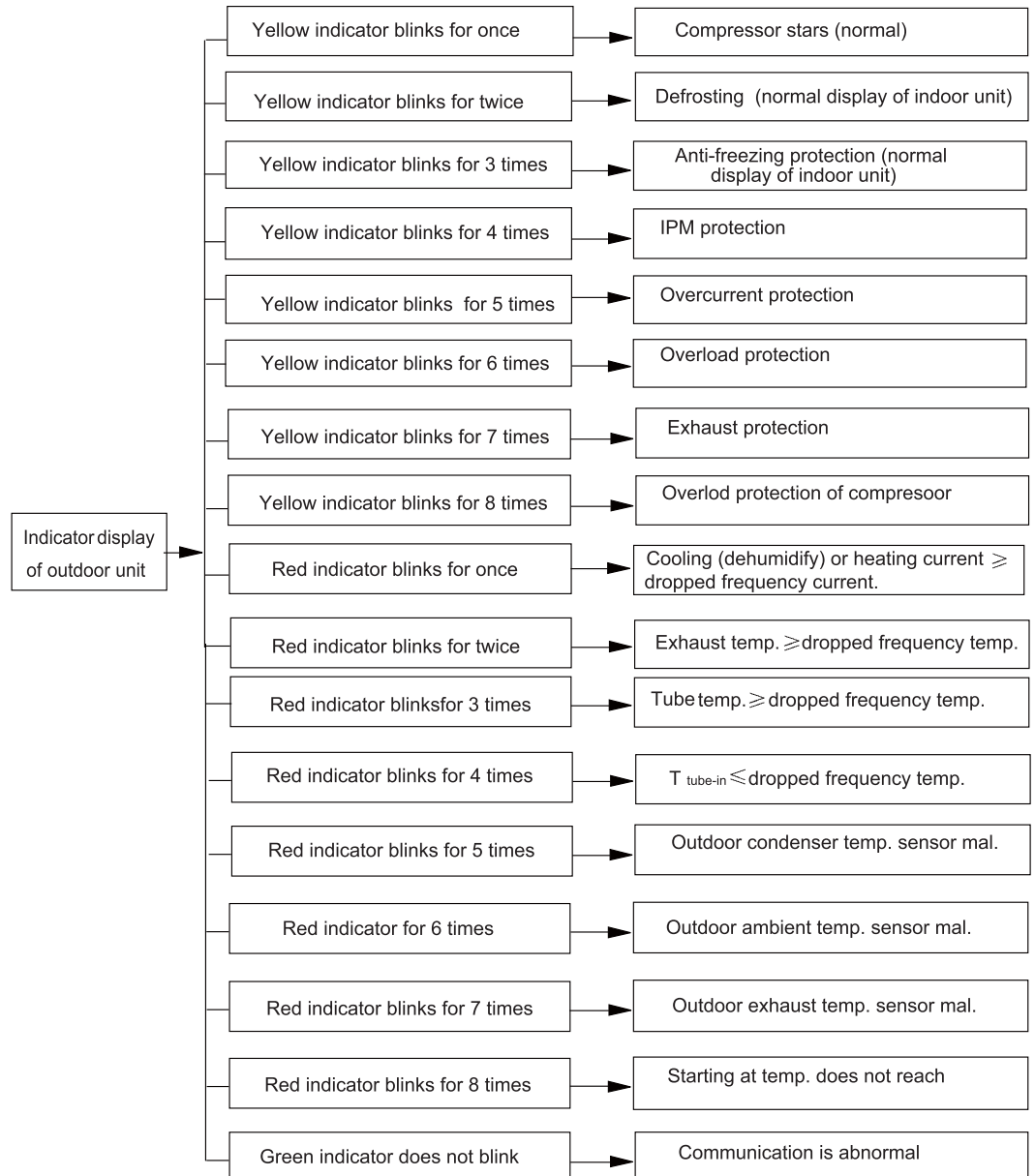

Analysis or processing of some of the malfunction display:

1. Compressor discharge protection

Possible causes: shortage of refrigerant; blockage of air filter; poor ventilation or air flow short pass for condenser; the system has noncondensing gas (such as air, water etc.); blockage of capillary assy (including filter); leakage inside four-way valve causes incorrect operation; malfunction of compressor; malfunction of protection relay; malfunction of discharge sensor; outdoor temperature too high.

Processing method: refer to the malfunction analysis in the above section.

2. Low voltage overcurrent protection

Possible cause: Sudden drop of supply voltage.

3. Communication malfunction

Processing method: Check if communication signal cable is connected reliably.

4. Sensor open or short circuit

Processing method: Check whether sensor is normal, connected with the corresponding position on the controller and if damage of lead wire is found.

5. Compressor over load protection

Possible causes: insufficient or too much refrigerant; blockage of capillary and increase of suction temp.; improper running of compressor, burning in or stuck of bearing, damage of discharge valve; malfunction of protector.

Processing method: adjust refrigerant amount; replace the capillary; replace the compressor; use universal meter to check if the contactor of compressor is fine when it is not overheated, if not replace the protector.

6. System malfunction

i.e. overload protection. When tube temperature (Check the temperature of outdoor heat exchanger when cooling and check the temperature of indoor heat exchanger when heating) is too high, protection will be activated.

Possible causes: Outdoor temperature is too high when cooling; insufficient outdoor air circulation; refrigerant flow malfunction. please refer to the malfunction analysis in the previous section for handling method.

7. IPM module protection

Processing method: Once the module malfunction happens, if it persists for a long time and can not be self-canceled, cut off the power and turn off the unit, and then re-energize the unit again after about 10 min. After repeating the procedure for several times, if the malfunction still exists, replace the module.

Applicable for 18 & 24K model

NO.	Name of malfunction	Indoor unit displaying method			Outdoor unit display(LEDs have 3 status) □ OFF ■ ON ☆ Blinks				AC status	Malfunctions	
		Double 8 code display	Indicator display(LED blinks 0.5s-ON/0.5s-OFF)			D40/D5	D41/D6	D42/D16			D43/D30
			Running LED	Cooling LED	Heating LED						
1	System high pressure protection	E1	3s off blink once			□	☆	☆	☆	cooling,dehumidifying,except the indoor fan motor is running,others will stop to run. heating;all stop running	High pressure of system,might be: 1.Refrigerant is too much; 2.Poor heating exchanging for units(including heat exchanger is dirty and unit heating radiating ambient is poor); 3.Ambient temp.is too high.
2	Anti-freezing protection	E2	3s off blink twice			■	□	■	□	cooling,dehumidifying,compressor,outdoor fan motor will stop running,indoor fan motor will keep running.	1.Poor indoor unit air returning; 2.Indoor fan motor rotating speed abnormal; 3.Evaporator is dirty;
3	Compressor air exhaust high temp. protection	E4	3s off blink four times			■	□	■	☆	cooling,dehumidifying,compressor,outdoor fan motor will stop running,indoor fan motor works. heating:all stop running.	Pls refer to trouble shoot (air exhaust protection,overload)
4	AC overload protection	E5	Off 3s blink 5 times			□	■	☆	□	Cooling,dehumidifying,compressor,outdoor fan motor will stop,indoor fan will work. heating;all will stop	1.power supply is stable,fluctuation is too much 2.Power supply is too low,overload is too much.
5	Indoor and outdoor units communication malfunction	E6	Off 3s blink 6 times			□	□	□	☆	Cooling,compressor will stop,indoor fan motor works,Heating:all will stop	Please refer to troubleshooting
6	Anti-high temp. protection	E8	Off 3s blink 8 times			■	□	■	■	Cooling,compressor will stop,indoor fan motor works,Heating:all will stop	Please refer to troubleshooting
7	Indoor unit motor no feedback	H6	Off 3s blink 11 times							Whole unit will stop to run	1.Poor insert for GPF 2.Indoor control board AP1 malfunction 3.Indoor motor M1 malfunction
8	Jump wire cap malfunction protection	C5	Off 3s blink 15 times							Whole unit will stop to run	Indoor control board AP1 jump cap poor connected,please reinsert or replace the jump cap.
9	Indoor ambient sensor open circuit,short circuit	F1		Off 3s blink once						Cooling,dehumidifying:indoor fan motor is running,other overloads will stop;Heating,whole unit will stop to run.	1.Room temp.sensor is not connected with the control panel AP1 2.Room temp.sensor is damaged
10	Indoor evaporator sensor circuit open,short circuit	F2		Off 3s blink twice						Cooling,dehumidifying;indoor fan motor running,other overload will stop;Heating,whole unit will stop.	1.Tube temp.sensor is not connected with the control panel AP1 2.Tube temp.sensor is damaged
11	Outdoor ambient sensor circuit open,circuit short	F3		Off 3s blinks three times			□	☆	■	Cooling,dehumidifying;compressor will stop,indoor fan motor will work.Heat:all will stop	Outdoorroom temp.sensor hasn't connected well,or damaged,please refer to the sensor resistance value for checking.
12	Outdoor condensor sensor open circuit,short circuit	F4		Off 3s blinks 4 times			□	☆	□	Cooling,dehumidifying;compressor will stop,indoor fan motor will work.Heat:all will stop	Outdoorroom temp.sensor hasn't connected well,or damaged,please refer to the sensor resistance value for checking.

13	Outdoor air exhaust sensor open circuit,short circuit	F5		Off 3s blinks 5 times	□	□	☆	☆	Cooling,dehumidifying;after runing for 3mins later,the compressor will stop to run,indoor fan motor will start to run.heating:after run 3 mins later,all will stop to run.	1.Exhaust temp sensor hasn't connected well,or damaged,plwase refer to the sensor resistance value for checking. 2.Sensor head hasn't insert into the copper tube.
14	Overload limit/descending frequency	F6		Off 3s blinks 6 times	■	□	☆	☆	Overload normal operation,compressor is runing,frequency descending	Please refer to troubleshooting
15	Over current need frequency descending	F8		Off 3s blinks 8 times	■	■	□	■	Overload normal operation,compressor is runing,frequency descending	1.Input power supply is too low 2.System voltage is too high,over is too much
16	Air exhaust over high need frequency descending	F9		Off 3s blinks 9 times	■	■	□	□	Overload normal operation,compressor is runing,frequency descending	1.Overload is too much,ambient temp.is too high 2.Refrigerant is short 3.Electric expansion malfunction
17	DC generatrix voltage is too high	PH		Off 3s blink 11 times	□	■	□	☆	Cooling,dehumidifying,co mpressor stop running,Fan motor works. Heating: all will stop	1. Testing wire terminal L and N position.If higher than 265VAC,please cut off the power supply and restart until back to normal 2.If input voltage is normal, testing the voltage of electrolytic capacitor on AP1 after turn on the unit.There may be some problem and replace the AP1 if the electrolytic capacitor voltage range at 200-280V
18	Whole unit's current testing malfunction	U9		Off 3s blink 13 times	□	■	☆	■	Cooling, dehumidifying;compressor stops running,indoor fan motor works. Heating: all will stop running	The circuit on AP1 has malfunction, replace the outdoor unit AP1
19	Compressor current overcurrent protection	P5		Off 3s blink 15 times	□	☆	□	□	Cooling, dehumidifying;compressor stops running,indoor fan motor works. Heating: all will stop running	Please refer to troubleshooting(IPM protection, compressor lose steps, compressor current overcurrent protection)
20	Defrosting	H1		Off 3s blink once					Under the heating mode,compressor running, indoor/outdoorfan motor stop working	It is normal function
21	Electrostatic dedust protection	H2		Off 3s blink twice						
22	Compressor overload protection	H3		Off 3s blink 3 times	□	☆	☆	□	Cooling, dehumidifying;compressor stops running,indoor fan motor works. Heating: all will stop running	1. Wire terminal OVCCOMP loosen or circuit,has problem, the resistance of SAT should be lower than 1 ohm. 2.Please refer to troubleshooting(exhaust/ overload protection)
23	System abnormal	H4		Off 3s blink 4 times					Cooling, dehumidifying;compressor stops running,indoor fan motor works. Heating: all will stop running	Pls refer to troubleshooting
24	IPM protection	H5		Off 3s blink 5 times	■	□	■	■	Cooling, dehumidifying;compressor stops running,indoor fan motor works. Heating: all will stop running	Pls refer to troubleshooting

Troubleshooting

25	PFC protection	HC			Off 3s blink 6 times	□	■	☆	☆	Cooling, dehumidifying;compressor stops running,indoor fan motor works. Heating: all will stop running	Pls refer to troubleshooting
26	Compressor lose steps	H7			Off 3s blink 7 times	□	☆	■	☆	Cooling, dehumidifying;compressor stops running,indoor fan motor works. Heating: all will stop running	Pls refer to troubleshooting
27	Heating, anti- high temp. declines	H0			Off 3s blink 10 times	■	□	☆	☆	Overload normal works,compressor running,frequency declines	Pls refer to troubleshooting
28	Startsup fail	Lc			Off 3s blink 11 times	□	☆	□	☆	Cooling, dehumidifying;compressor stops running,indoor fan motor works. Heating: all will stop running	Pls refer to troubleshooting
29	Compressor current testing circuit malfunction	U1			Off 3s blink 13 times	□	☆	■	□		Replace the outdoor control board AP1
30	EEPROM malfunction	EE			Off 3s blink 15 times	□	□	□	■	Cooling, dehumidifying;compressor stops running,indoor fan motor works. Heating: all will stop running	Replace the outdoor control board AP1
31	Capacitor charge malfunction	PU			Off 3s blink 17 times	□	■	□	■	Cooling, dehumidifying;compressor stops running,indoor fan motor works. Heating: all will stop running	Pls refer to Part 3 capacitor charging fault of troubleshooting
32	Module sensor circuit diagram	P7			Off 3s blink 18 times	□	□	■	☆	Cooling, dehumidifying;compressor stops running,indoor fan motor works. Heating: all will stop running	Replace the outdoor control board AP1
33	Module temp. over high protection	P8			Off 3s blink 19 times	■	□	☆	■	Cooling, dehumidifying;compressor stops running,indoor fan motor works. Heating: all will stop running	To check whether the ambient Temp. of IPM is too high or the heat-sinhing of IPM is dirty else replace the outdoor baord AP1
34	DC Bus voltage dips	U3			Off 3s blink 20 times	□	■	■	■	Cooling, dehumidifying;compressor stops running,indoor fan motor works. Heating: all will stop running	Power voltage is not stable
35	Low DC Bus voltage protection	PL			Off 3s blink 21 times	□	■	■	□	Cooling, dehumidifying;compressor stops running,indoor fan motor works. Heating: all will stop running	1.Check the Input voltage if the Voltage is lower than 150VAC,restart the machine when the power supply is normal. 2.Checking the reactor L connection.
36	IPM temp.is too high limit/ decrease frequency	EU				■	■	■	☆	Over load normal works,compressor runing frequency declines	Whole unit break for 20 mins and discharge,to check the outdoor control board AP1's IPM module coolant whether is short,the radiator is tightened. If above phenomenon is not OK,Please improve or replace the control board AP1
37	Four-way valve abnormal	U7				■	□	☆	□	This malfunction happened,only in heating mode,all will stop to run.	1.Power supply voltage is lower than AC175V 2.Wire terminal 4V loosen or wire break 3.4V damaged,replace 4V
38	Outdoor unit zero-cross detecting error	U9				■	■	☆	□	Cooling:compressor will stop,indoor fan motor works. Heating:all will stop.	Replace the outdoor control board AP1

39	Anti-freezing limit/decrease frequency	FH				■	■	■	□	All loads work normally but the running frequency limited or decrease	Indoor unit air return is poor or fan speed is to low.
40	Fan module protection	L3				■	□	□	□	Cooling:outdoor fan motor,compressor stop running;indoor fan works. Heating:outdoor fan motor,compressor,indoor fan motor stop running.	1.The wire terminal of outdoor fan motor is loosed,fix the terminal. 2.Motor damaged,replace the motor 3.Fan motor module on mainboard is damaged;replace the mainboard AP1

Key test point (bottom layer)

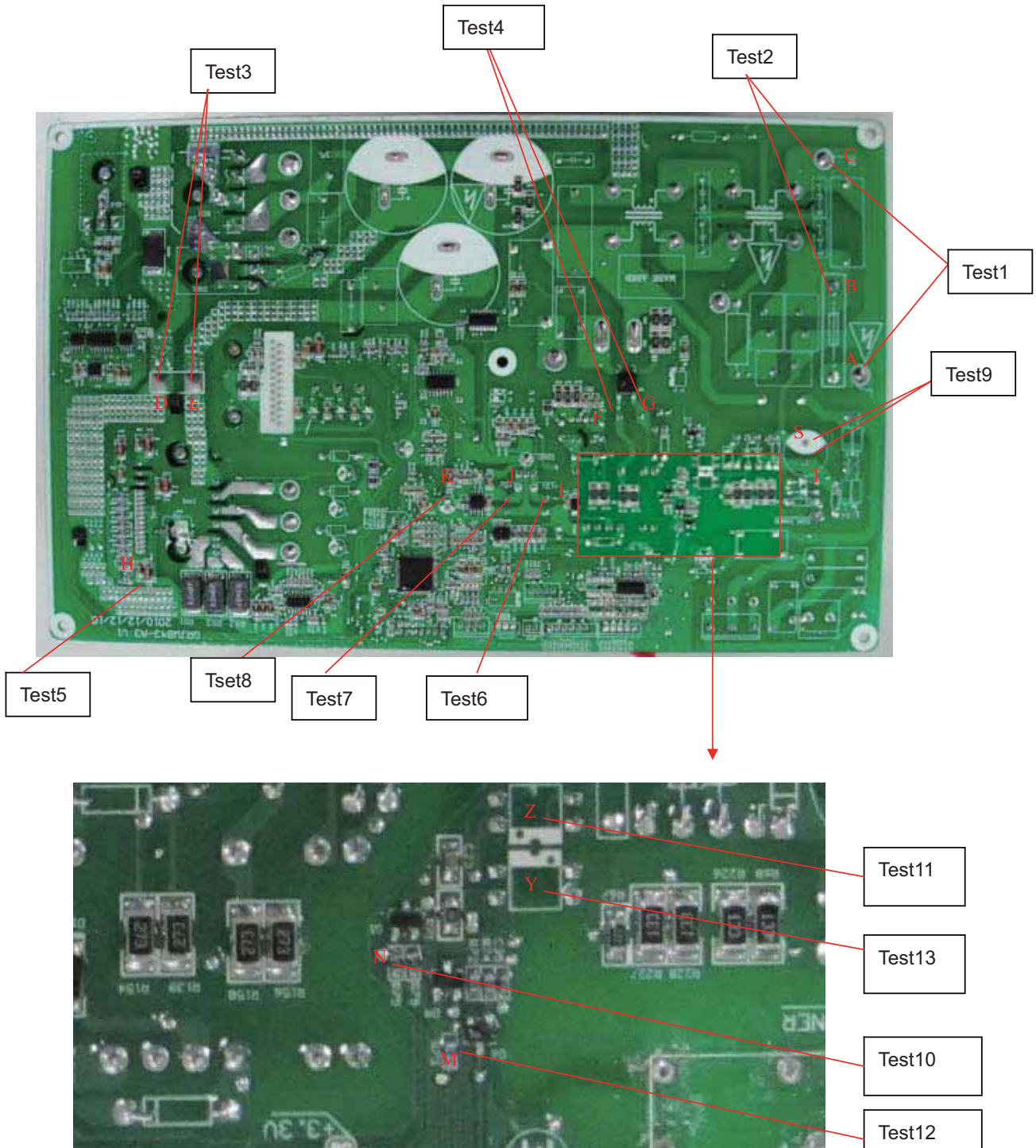

Test point No.	Test point	Related elements	Test value under normal condition
Test 1	Between A and C	Neutralwire, live wire	160V-265V
Test 2	Between B and C	Neutralwire, live wire	160V-265V
Test 3	Between D and E	Electrolytic capacitor of DC bus bar	DC 180V-380V
Test 4	Between F and G	Electrolytic capacitor of switch power	DC 180V-380V
Test 5	Both ends of diode D10	D10 (IPM module +15V)	DC 14.5V-15.6V
Test 6	Both ends of electrolytic capacitor C40	C40 (+12V power)	DC 12V-13V
Test 7	Both ends of electrolytic capacitor C82	C82 (+5V power)	DC 5V
Test 8	Both ends of electrolytic capacitor C225	C225 (+3.3V power)	DC 3.3V
Test 9	Between S and T	Communication circular current	DC 56V
Test 10	Between point N and GND	R78 to N terminal (ground) (signal receiving terminal of outdoor unit)	Jumping between 0V and 3.3V
Test 11	U12	Between 1 and 2 at leading foot of U12	Jumping between 0V and 3.3V
Test 12	Between point M and GND	R75 to M terminal(ground) (signal sending terminal of outdoor unit)	Jumping between 0V and 3.3V
Test 13	U15	Between 3 and 4 at leading foot of U15	Jumping between 0V and 3.3V

●Discharging method

(1) remove the inverter cover(Outdoor Unit)

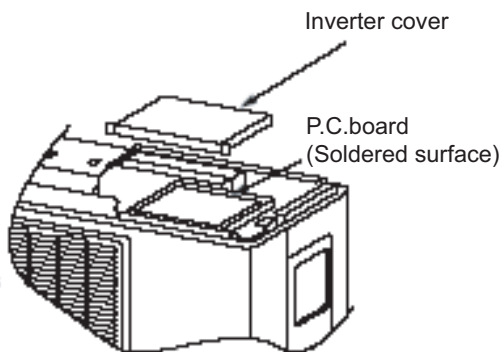

(2)As shown below,connect the discharge resistance(approx.100Ω20W)or plug of the sold ering iron to voltage between + - terminals of the electrolytic capacitor (test3 “D ” and “E” point) on PC Board for 30s, and then peformedischarging.

NOTE:

A large-capacity electrolytic capacitor is used in the outdoor unit controller(inverter).Therefore,if the power supply is turned off,charge(charging voltage DC280V to 380V)remains and disc harging takes a lot of time.. After turning off the power source,if touching the charging section before discharging, an electrical shock may be caused. Discharge the electrol ytic capacitor completely by using soldering iron,etc.

9.3 How to Check Simply the Main Part

Applicable for 09 & 12K model

(1) Capacitor charge fault (Fault with outdoor unit) (AP1 below refers to the outdoor control panel)

Main Check Points:

- Use AC voltmeter to check if the voltage between terminal L and N on the wiring board is within 210VAC~240VAC.
- Is the reactor (L) correctly connected? Is the connection loose or fallen? Is the reactor (L) damaged?

Fault diagnosis process:

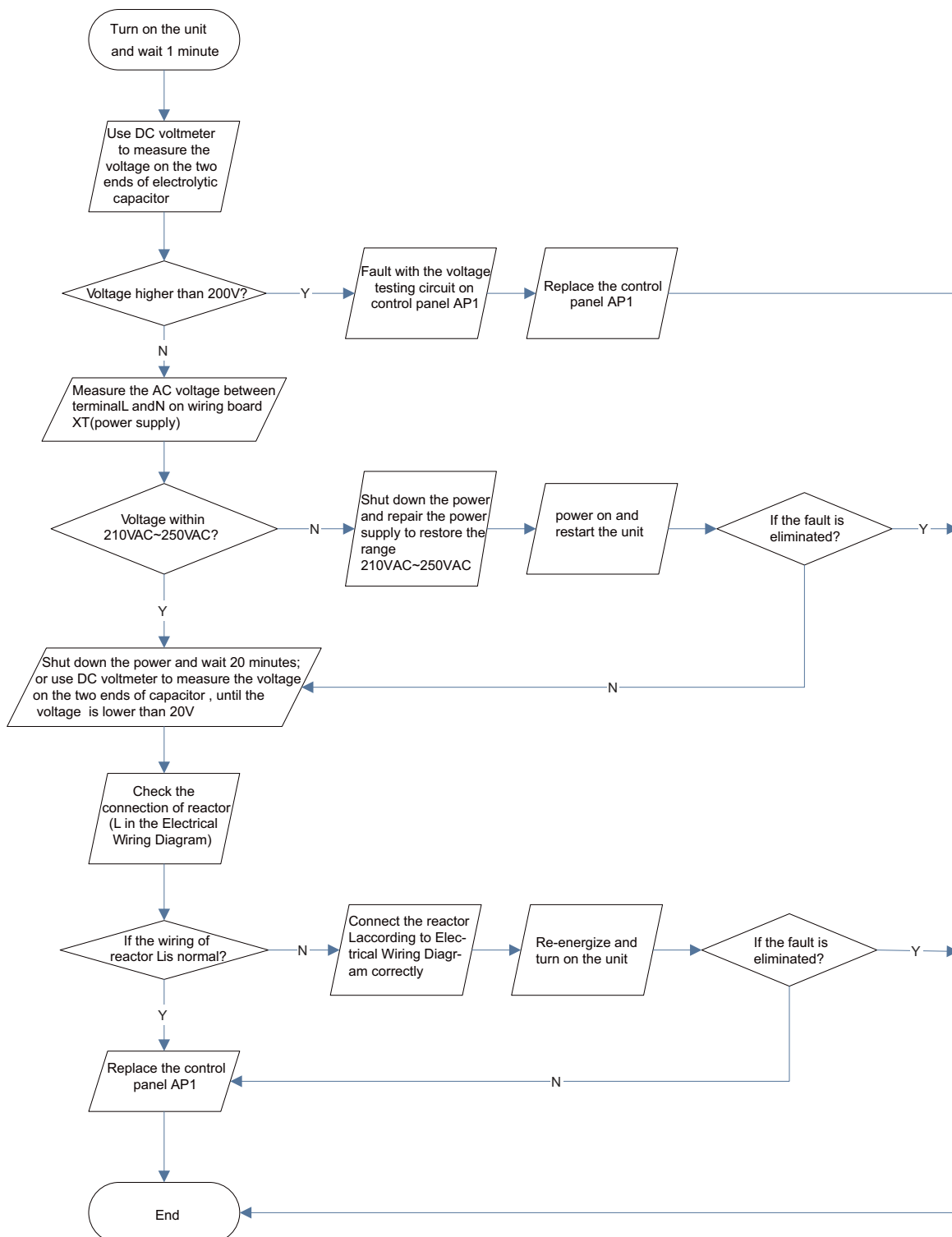

(2) IPM Protection, Out-of-step Fault, Compressor Phase Overcurrent (AP1 below refers to the outdoor control panel)

Main check points:

- Is the connection between control panel AP1 and compressor COMP secure? Loose? Is the connection in correct order?
- Is the voltage input of the machine within normal range? (Use AC voltmeter to measure the voltage between terminal L and N on the wiring board XT)
- Is the compressor coil resistance normal? Is the insulation of compressor coil against the copper tube in good condition?
- Is the working load of the machine too high? Is the radiation good?
- Is the charge volume of refrigerant correct?

Fault diagnosis process:

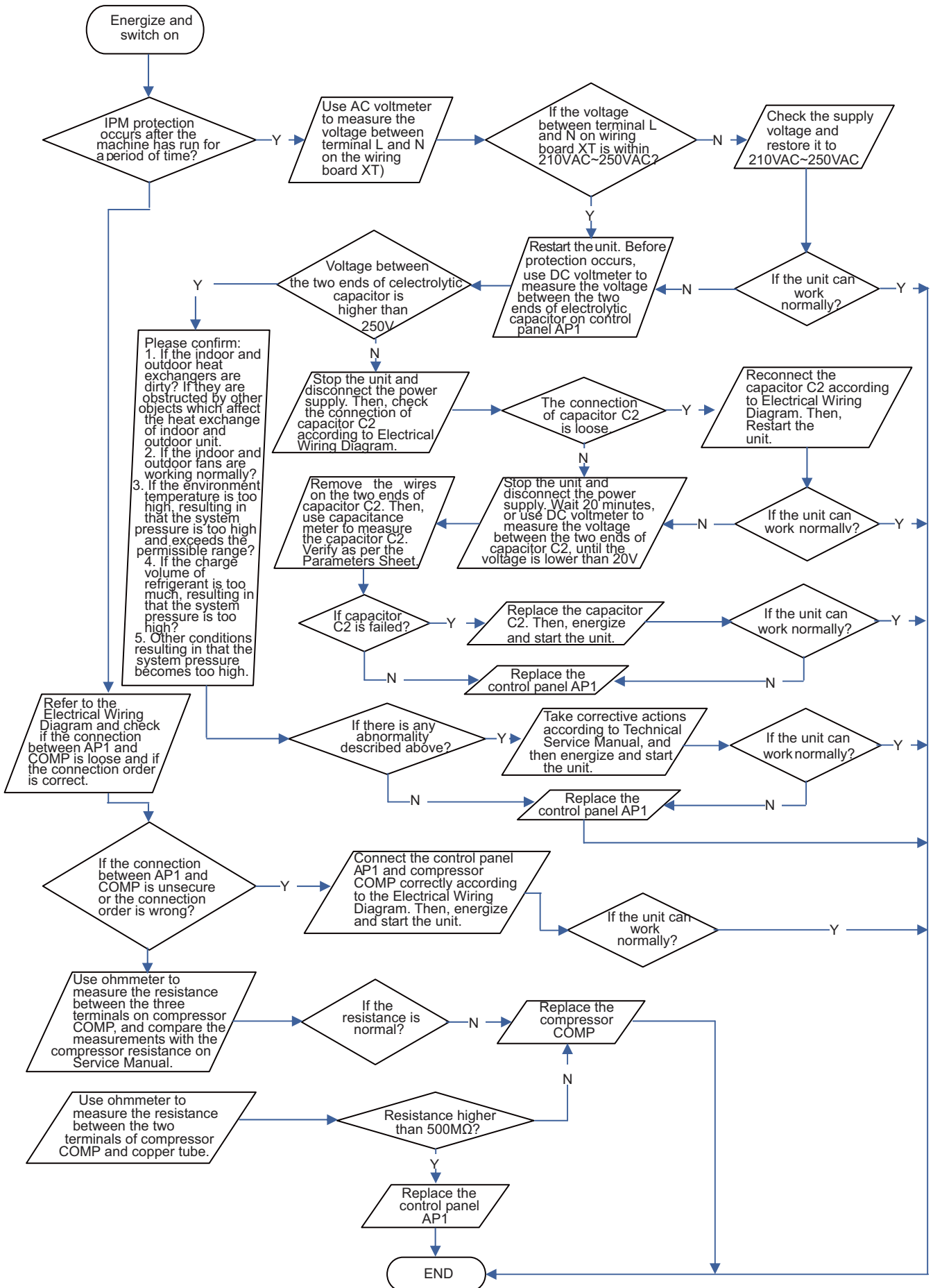

(3)High temperature and overload protection diagnosis (AP1 hereinafter refers to the control board of the outdoor unit)

Mainly detect:

- Is outdoor ambient temperature in normal range?
- Are the outdoor and indoor fans operating normally?
- Is the heat dissipation environment inside and outside the unit good?

Fault diagnosis process:

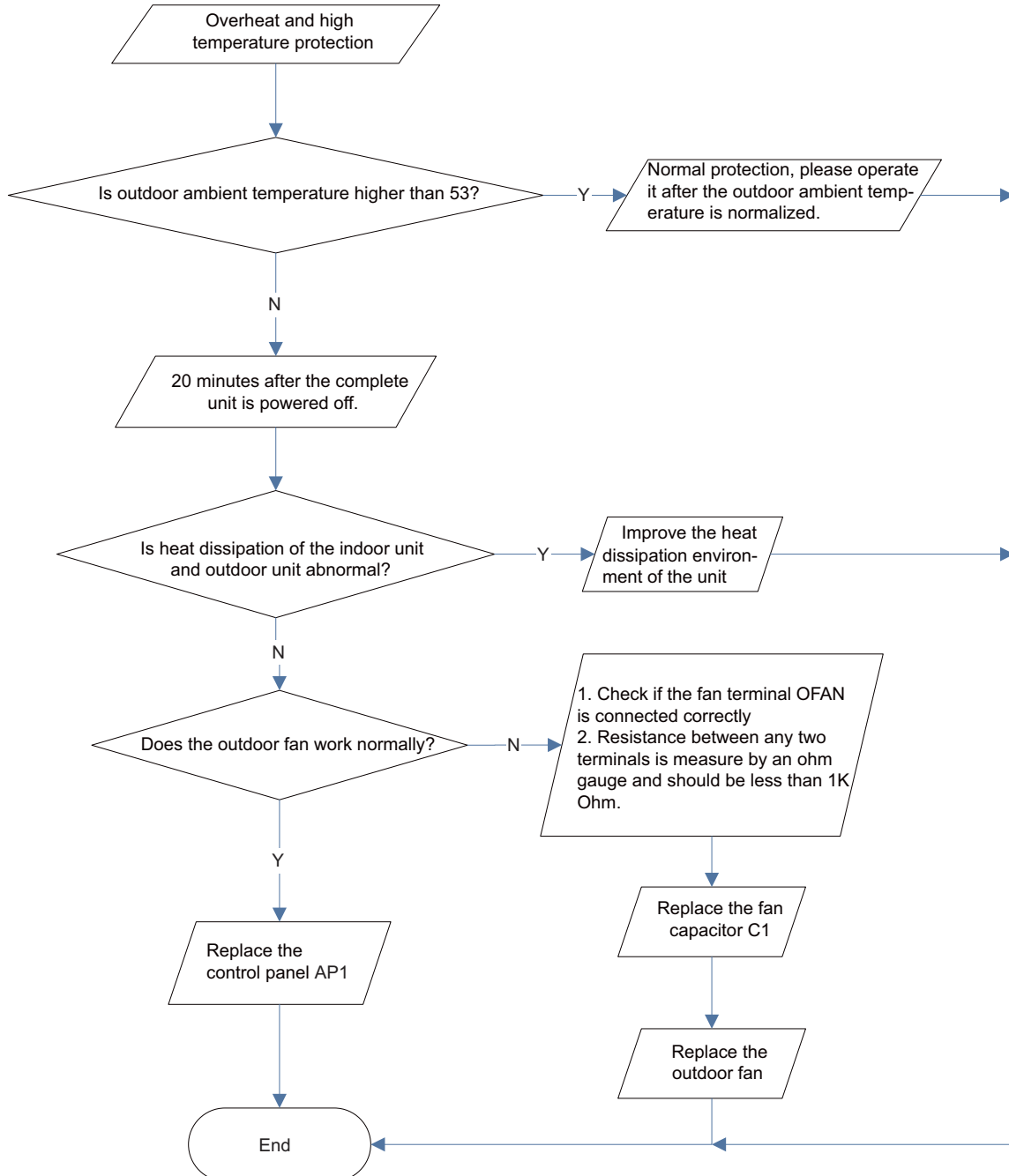

(4) Start-up failure (following AP1 for outdoor unit control board)

Mainly detect:

- Whether the compressor wiring is connected correct?
- Is compressor broken?
- Is time for compressor stopping enough?

Fault diagnosis process:

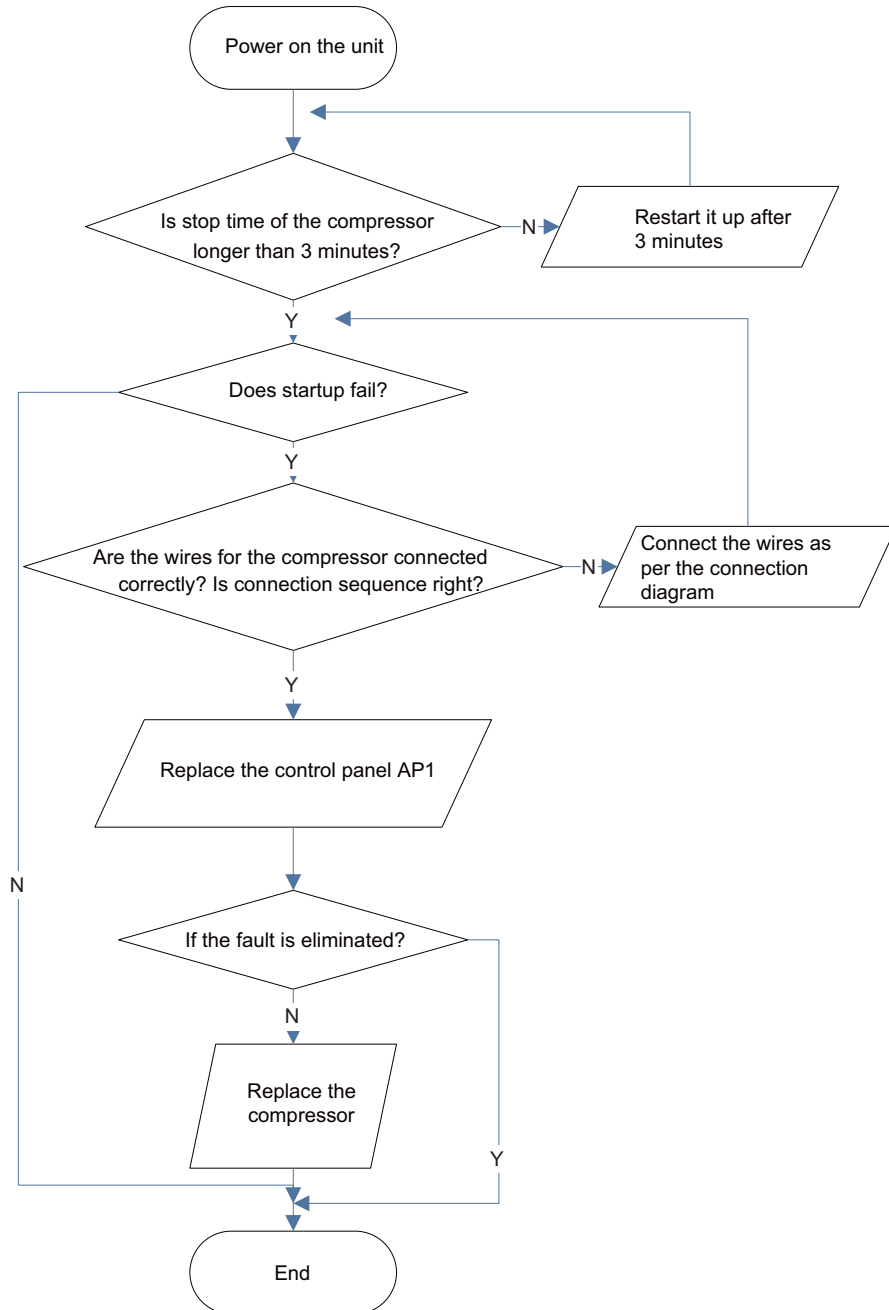

(5) Out of step diagnosis for the compressor (AP1 hereinafter refers to the control board of the outdoor unit)

Mainly detect:

- Is the system pressure too high?
- Is the input voltage too low?

Fault diagnosis process:

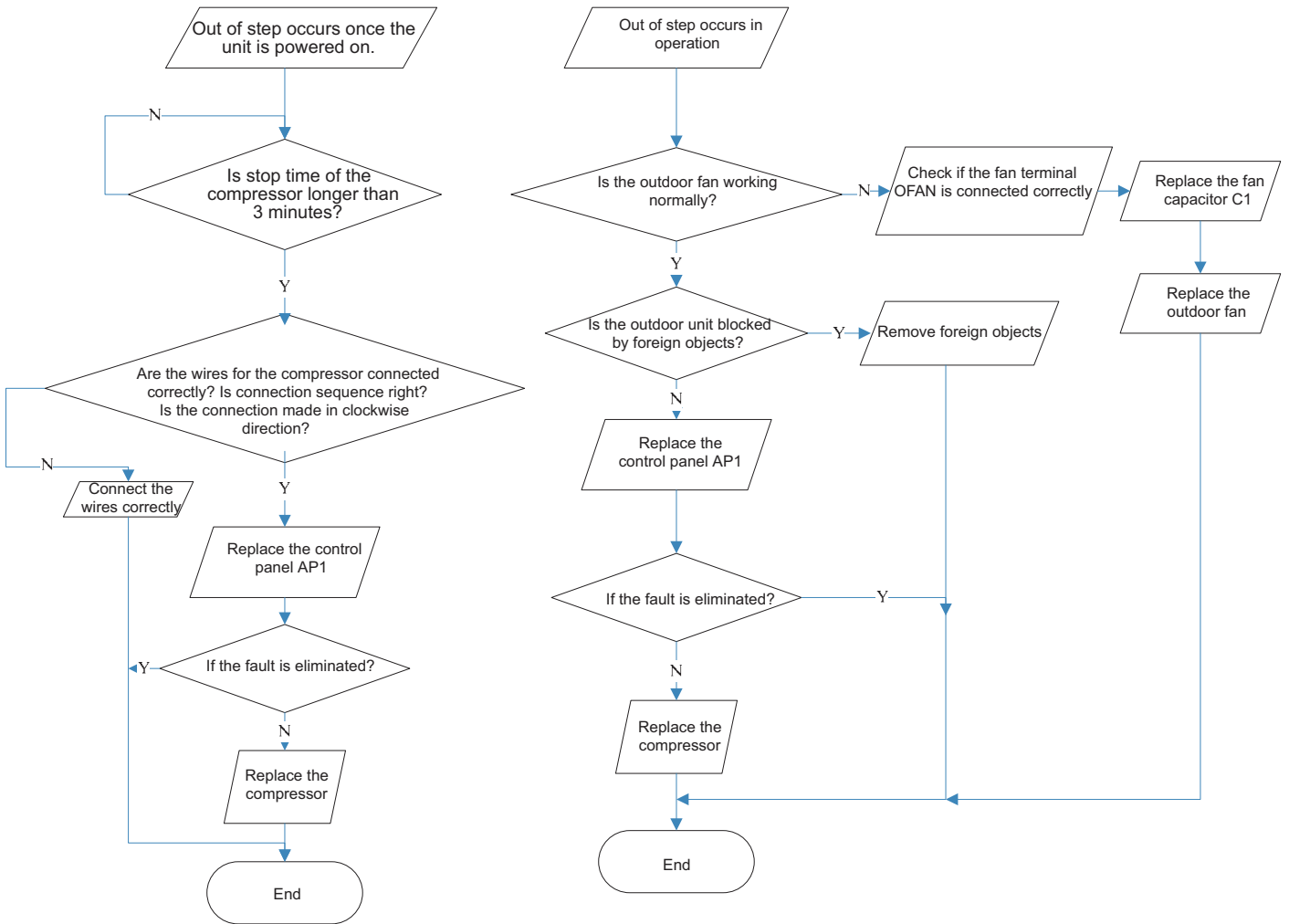

(6) Overload and air exhaust malfunction diagnosis (following AP1 for outdoor unit control board)

Mainly detect:

- Is the PMV connected well or not? Is PMV damaged?
- Is refrigerant leaked?

Fault diagnosis process:

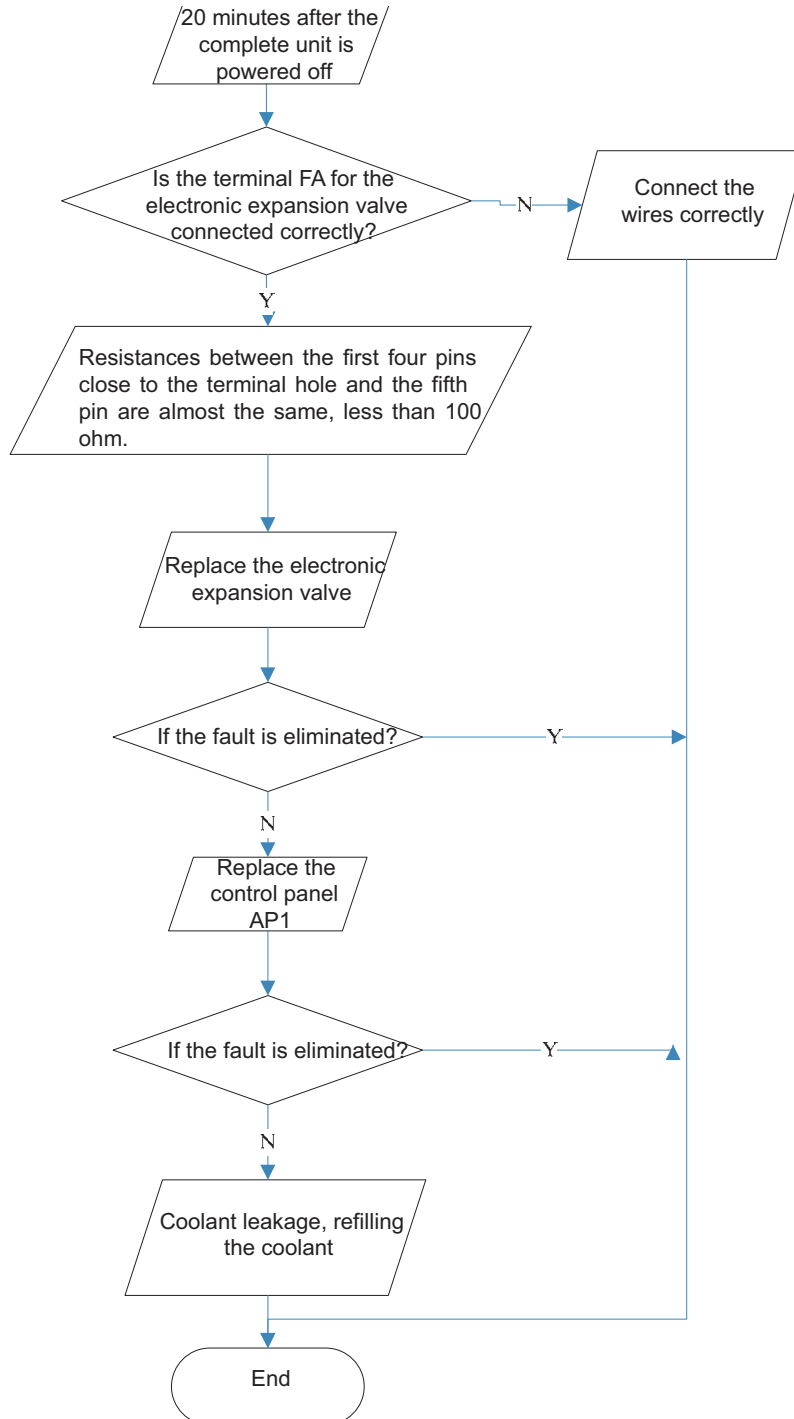

(7)Power factor correct or (PFC) fault (a fault of outdoor unit) (AP1 hereinafter refers to the control board of the outdoor unit)

Mainly detect:

- Check if the reactor (L) of the outdoor unit and the PFC capacitor are broken

Fault diagnosis process:

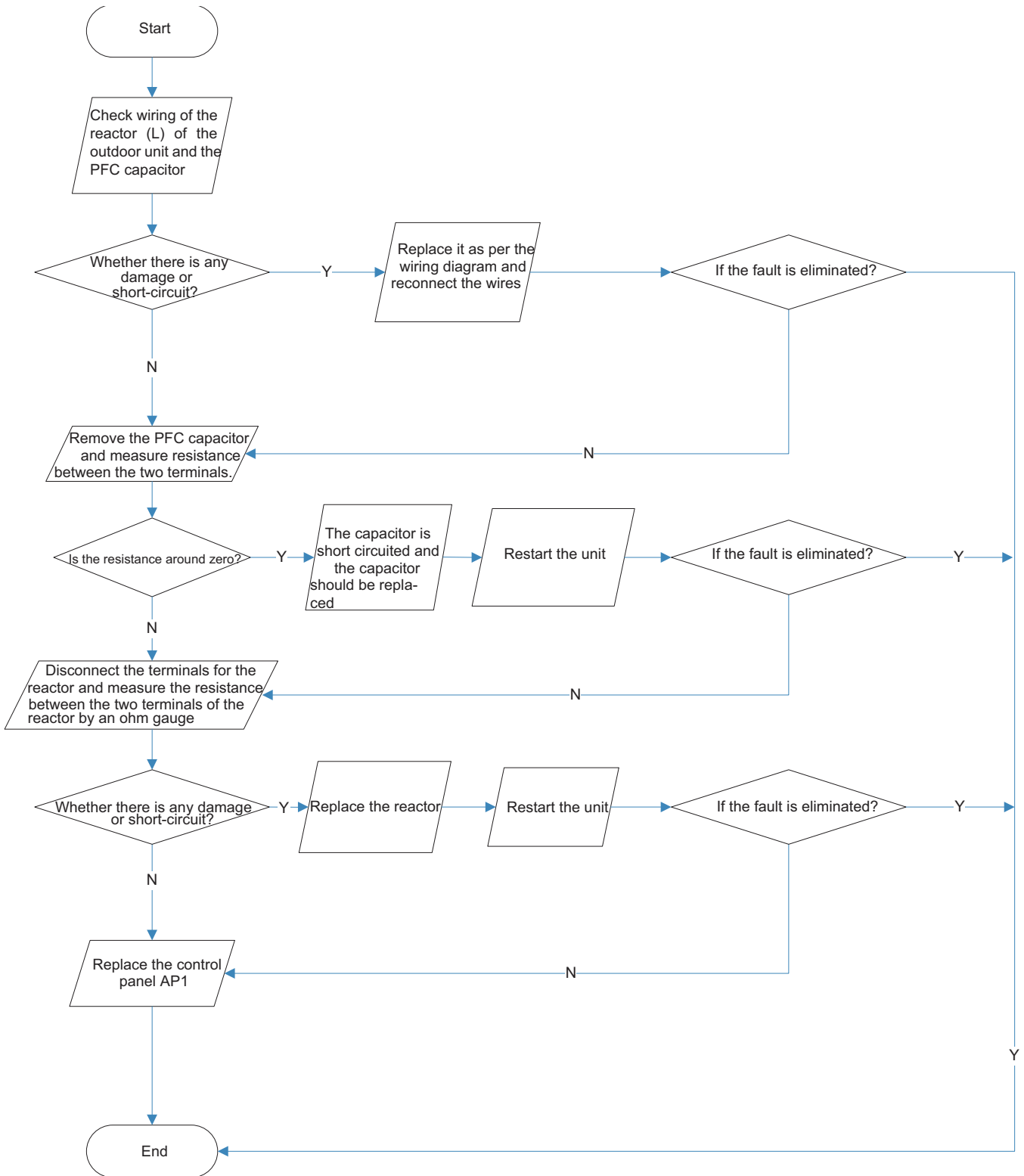

(8) Communication malfunction: (following AP1 for outdoor unit control board)

Mainly detect:

- Is there any damage for the indoor unit mainboard communication circuit? Is communication circuit damaged?
- Detect the indoor and outdoor units connection wire and indoor and outdoor units inside wiring is connect well or not, if is there any damage?

Fault diagnosis process:

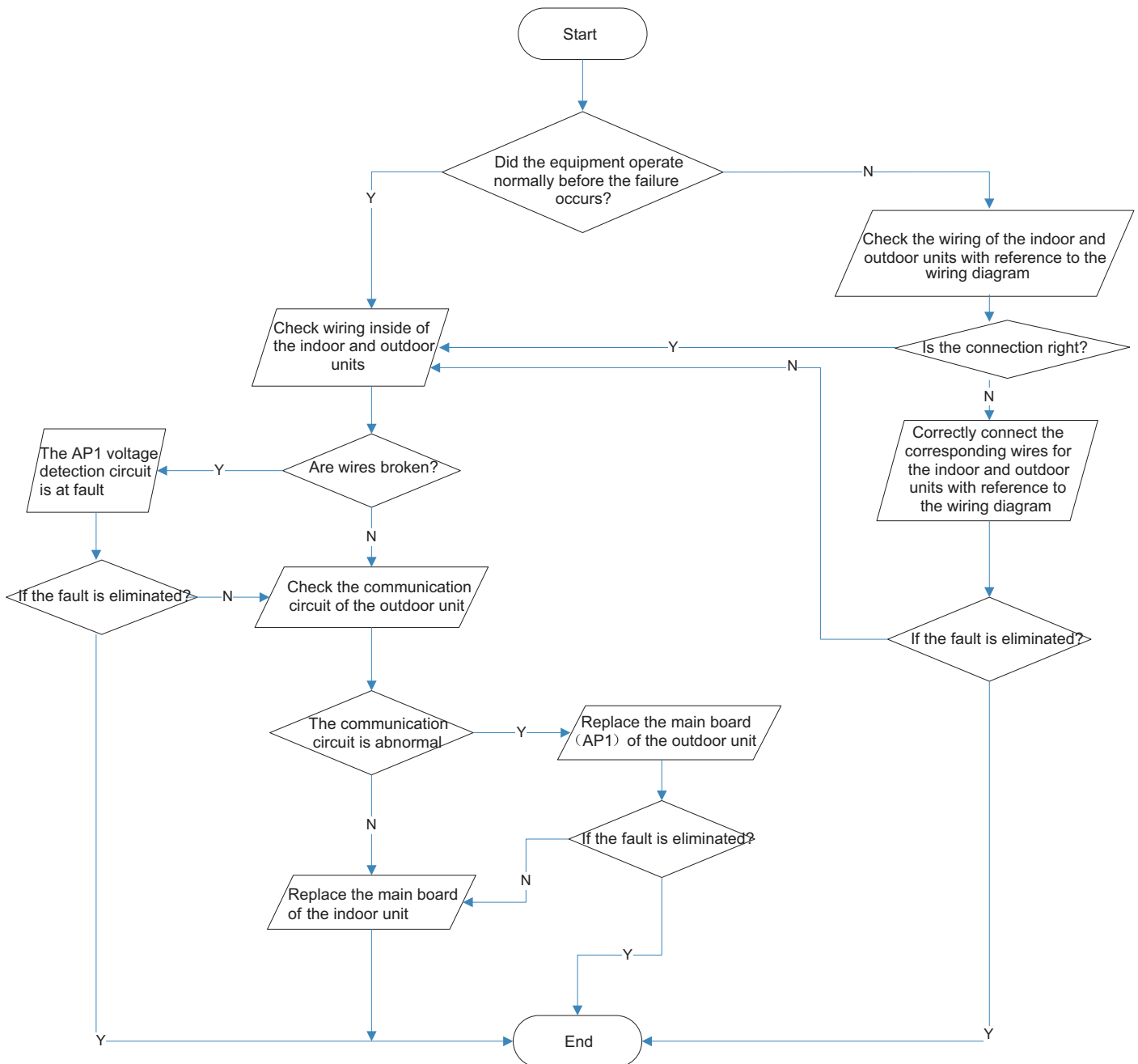

Applicable for 18 & 24K model

Confirm the malfunction type according to the malfunction indicator of indoor/outdoor unit and malfunction sheet (usually the sheet will be stuck on the electric box cover or top cover of the unit).

As long as there is a malfunction, the indicator of the outdoor controller board will display the corresponding malfunction directly; Some malfunctions will be displayed on the indoor unit directly and some malfunctions will be seen on the remote controller by pressing light button for 4 times in 3 seconds.

In the below malfunction diagnosis process, "Y" means "Yes", "N" means "No";

In the below malfunction diagnosis process, controller board AP1 is for outdoor controller board;

Before proceeding malfunction check, discharge the electrolytic capacitor according to the method mentioned before and make sure the voltage is below 20V. Otherwise, it may cause electric shock or break the controller board!

(1) Capacitor charging malfunction (outdoor unit malfunction)

Outdoor unit malfunction indicator status

D5	D6	D16	D30
□	■	□	■

Main detection point:

- Detect if the voltage of L and N terminal of wiring board is between 210AC-240AC by alternating voltage meter;
- Is reactor (L) well connected? Is connection wire loosened or pull-out? Is reactor (L) damaged?

Malfunction diagnosis process:

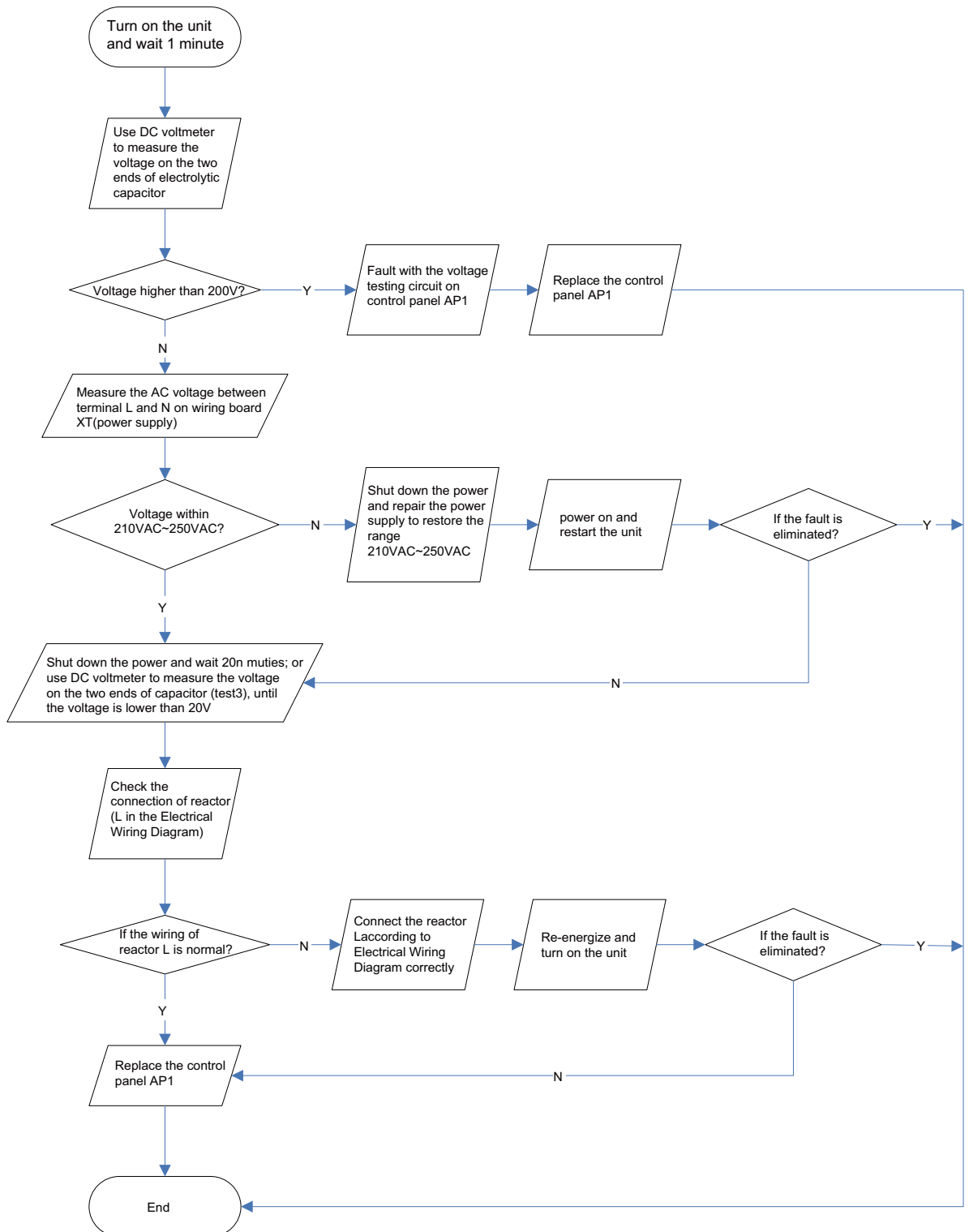

(2) IPM protection, desynchronizing malfunction, phase current of compressor is overcurrent (outdoor unit malfunction)

Outdoor unit malfunction indicator status

Malfunction	D5	D6	D16	D30
IPM protection	<input type="checkbox"/>	☆	<input type="checkbox"/>	■
Desynchronizing malfunction	<input type="checkbox"/>	☆	■	☆
Compressor overcurrent	<input type="checkbox"/>	☆	<input type="checkbox"/>	<input type="checkbox"/>

Main detection point:

- If control board AP1 and compressor COMP is well connected? If they are loosened? If the connection sequence is correct?
- Is voltage input in the normal range (Test the voltage between L, N of wiring board XT by DC voltage meter)?
- If coil resistance of compressor is normal? Is compressor coil insulating to copper pipe well?
- If the work load of unit is heavy? If radiating of unit is well? If the refrigerant charging is appropriate?

Malfunction diagnosis process:

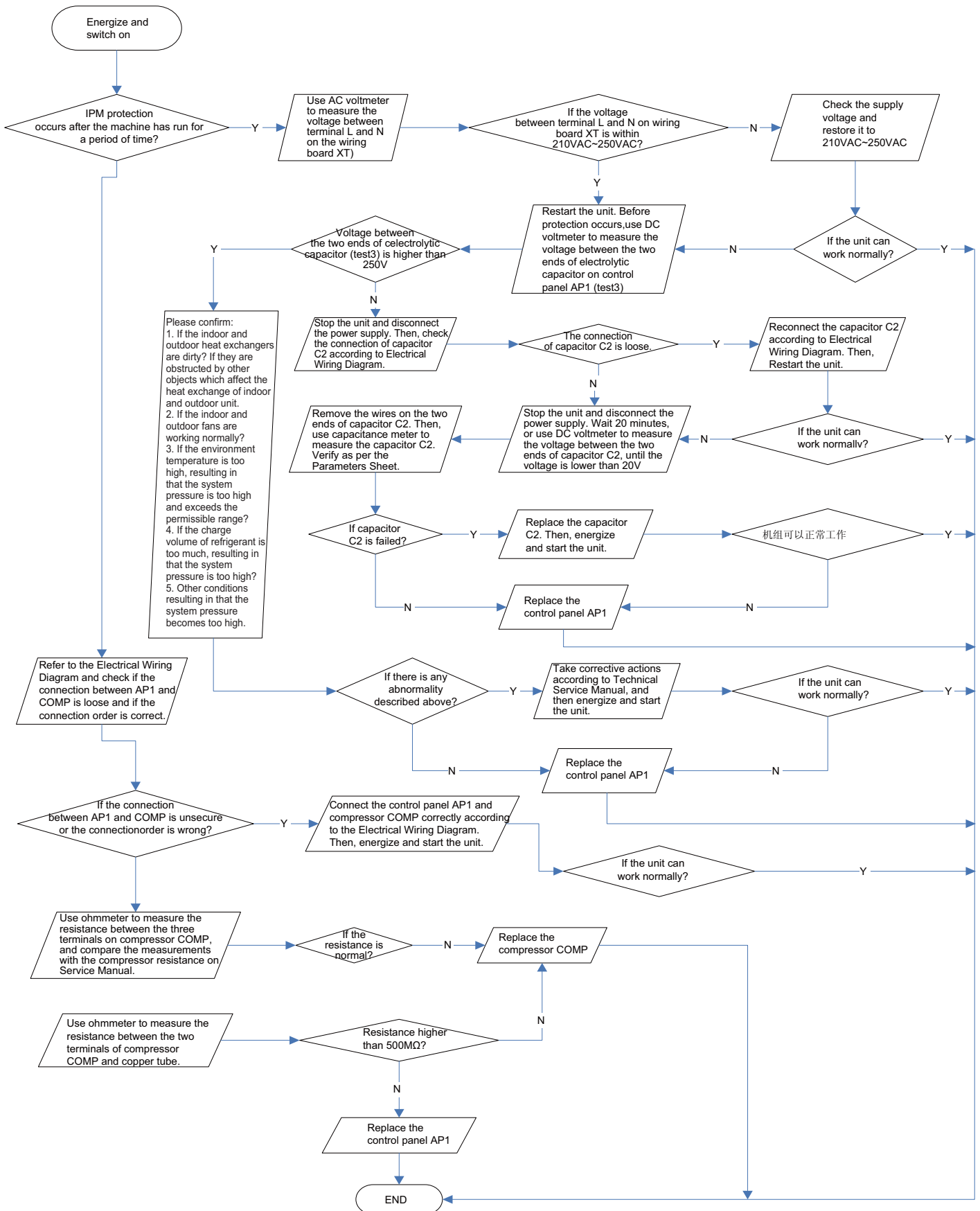

**(3) Diagnosis for high temperature, overload protection
(check outdoor unit in cooling mode and check indoor unit in heating mode)**

Outdoor unit malfunction indicator status

D5	D6	D16	D30
■	□	■	■

Main detection point:

- If the outdoor ambient temperature is in normal range;
- If the indoor and outdoor fan is running normally;
- If the radiating environment inside and outside the unit is well (including if the fan speed is too low)?
- If the tube temperature sensor of indoor and outdoor unit is normal?

Malfunction diagnosis process:

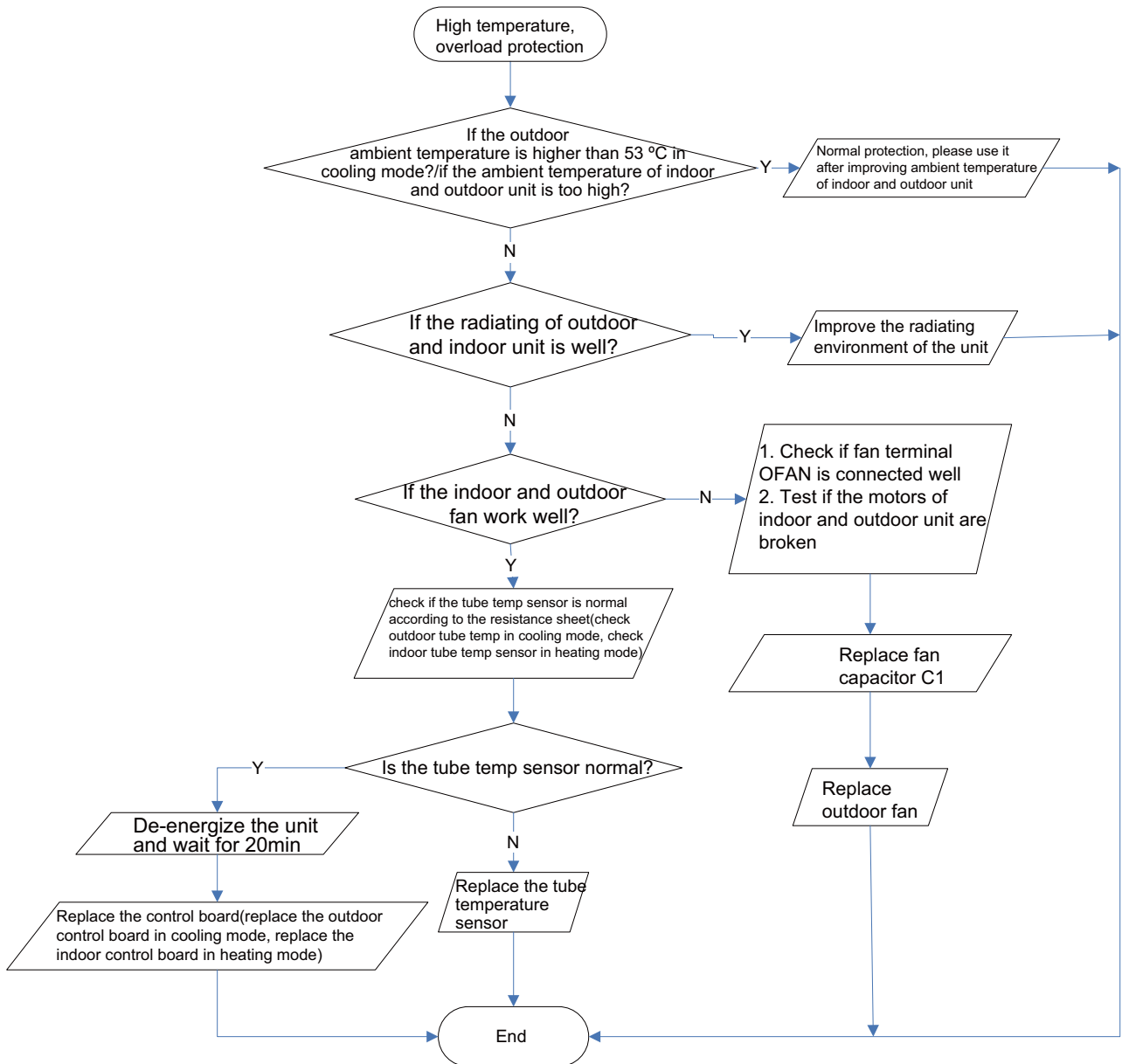

(4) Diagnosis for failure start up malfunction (outdoor unit malfunction)

Outdoor unit malfunction indicator status

D5	D6	D16	D30
□	☆	□	☆

Main detection point:

- If the compressor wiring is correct?
- If the stop time of compressor is enough?
- If the compressor is damaged?
- If the refrigerant charging is too much?

Malfunction diagnosis process:

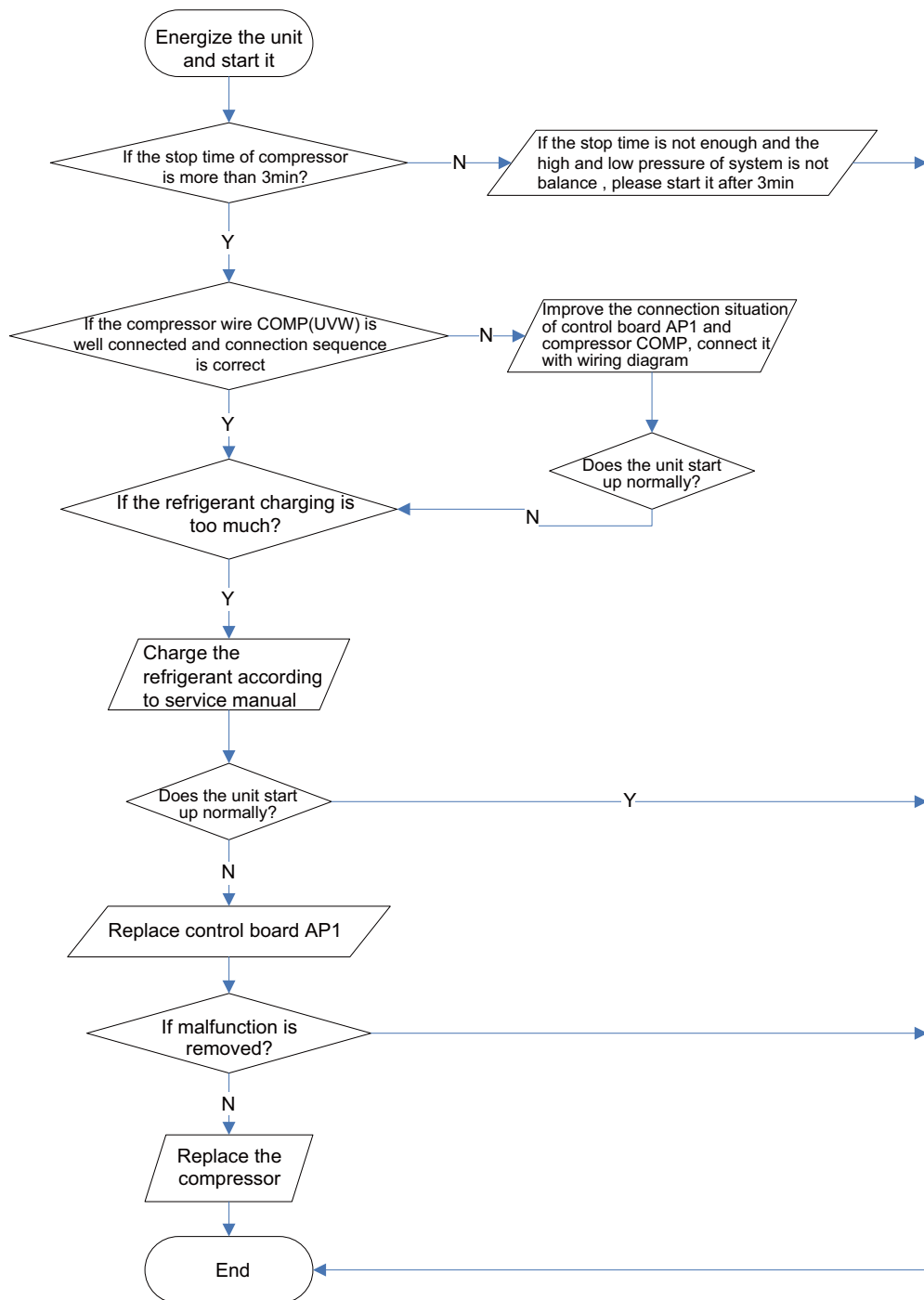

(5) Diagnosis for compressor synchronism (outdoor unit malfunction)

Outdoor unit malfunction indicator status

D5	D6	D16	D30
□	☆	■	☆

Main detection point:

- If the system pressure is over-high?
- If the working voltage is over-low?

Malfunction diagnosis process:

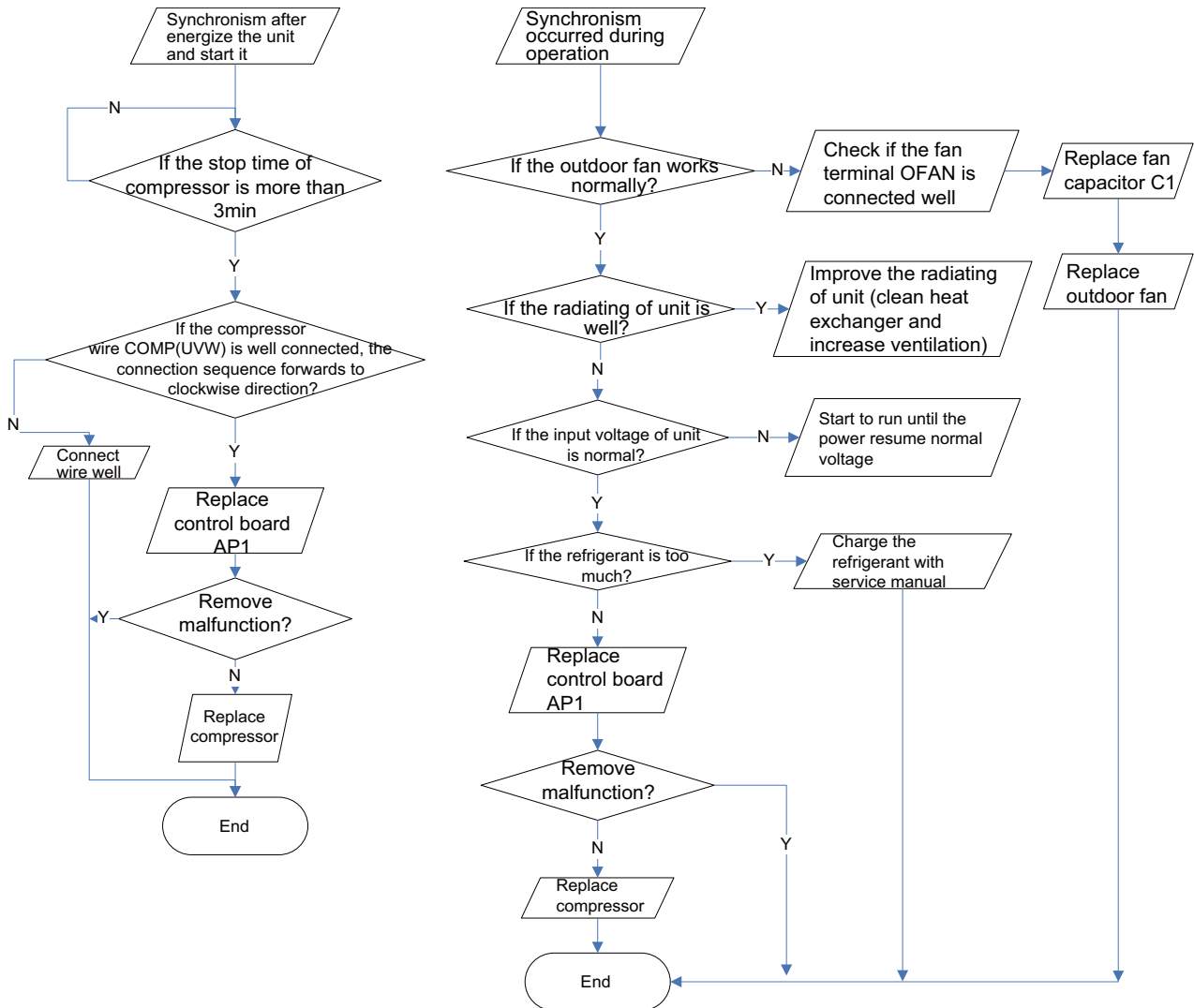

(6)Diagnosis for overload and discharge malfunction (outdoor unit malfunction)

Outdoor unit malfunction indicator status

Malfunction	D5	D6	D16	D30
Overload	□	☆	☆	□
Discharge	■	□	■	☆

Main detection point:

- If the electron expansion valve is connected well? Is the expansion valve damaged?
- If the refrigerant is leakage?
- If the overload protector is damaged?
- If the discharge temp sensor is damaged?

Malfunction diagnosis process:

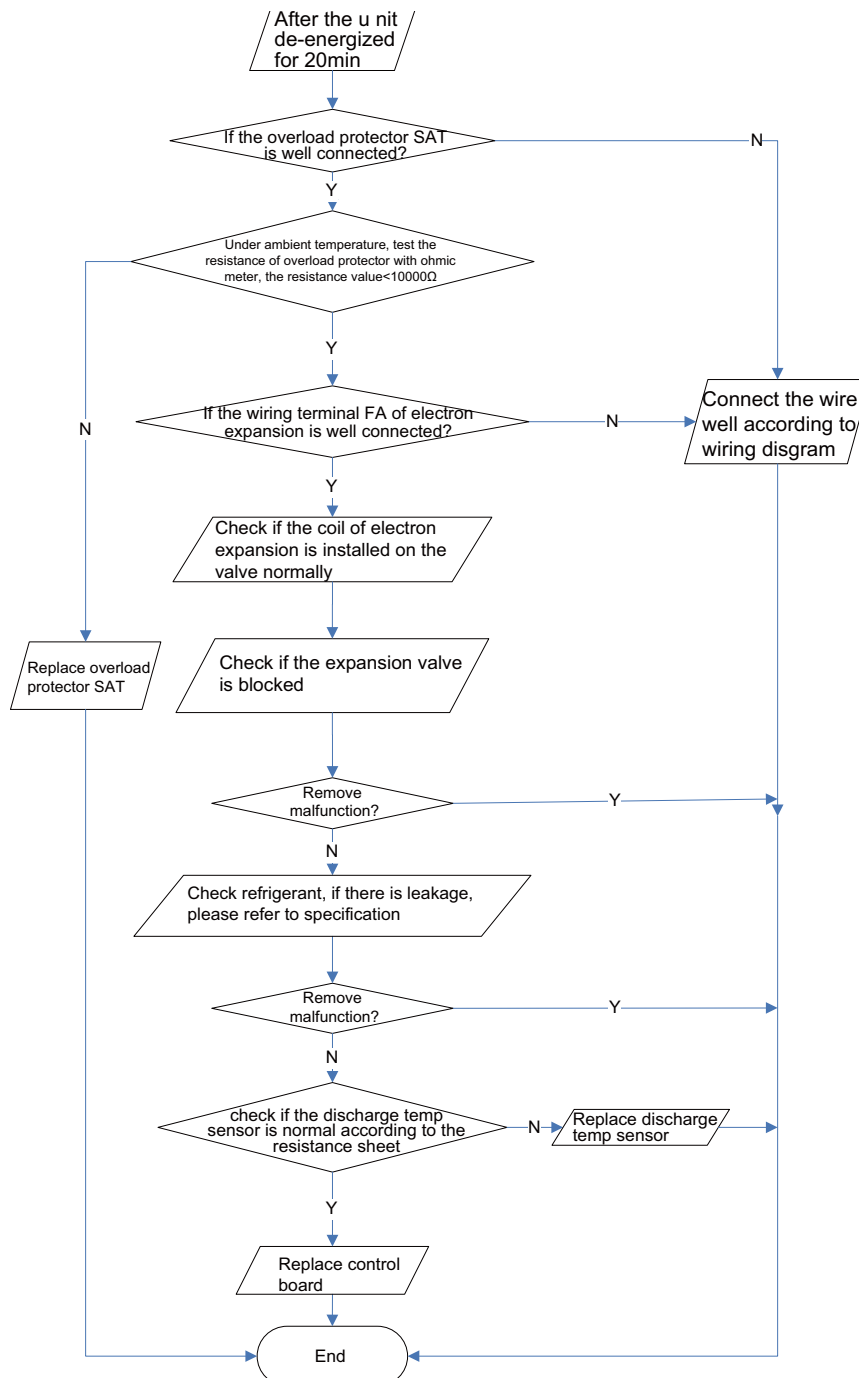

(7) Communication malfunction

Outdoor unit malfunction indicator status

D5	D6	D16	D30
□	□	□	☆

Main detection point:

- Check if the connection wire and the built-in wiring of indoor and outdoor unit is connected well and no damaged;
- If the communication circuit of indoor mainboard is damaged? If the communication circuit of outdoor mainboard (AP1) is damaged?

Malfunction diagnosis process:

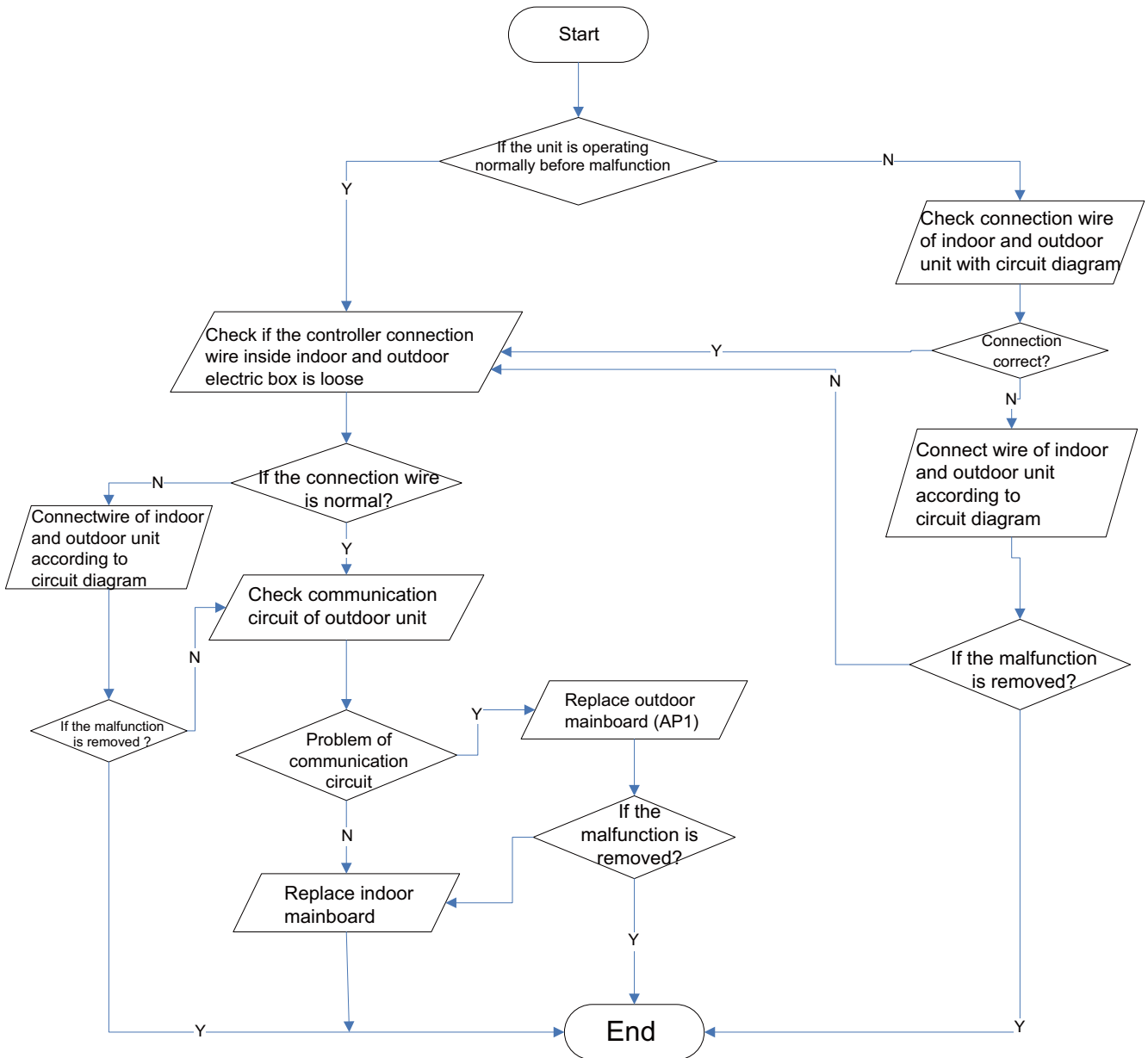

Diagnosis process for outdoor communication circuit (refer to the key detection points of outdoor unit)

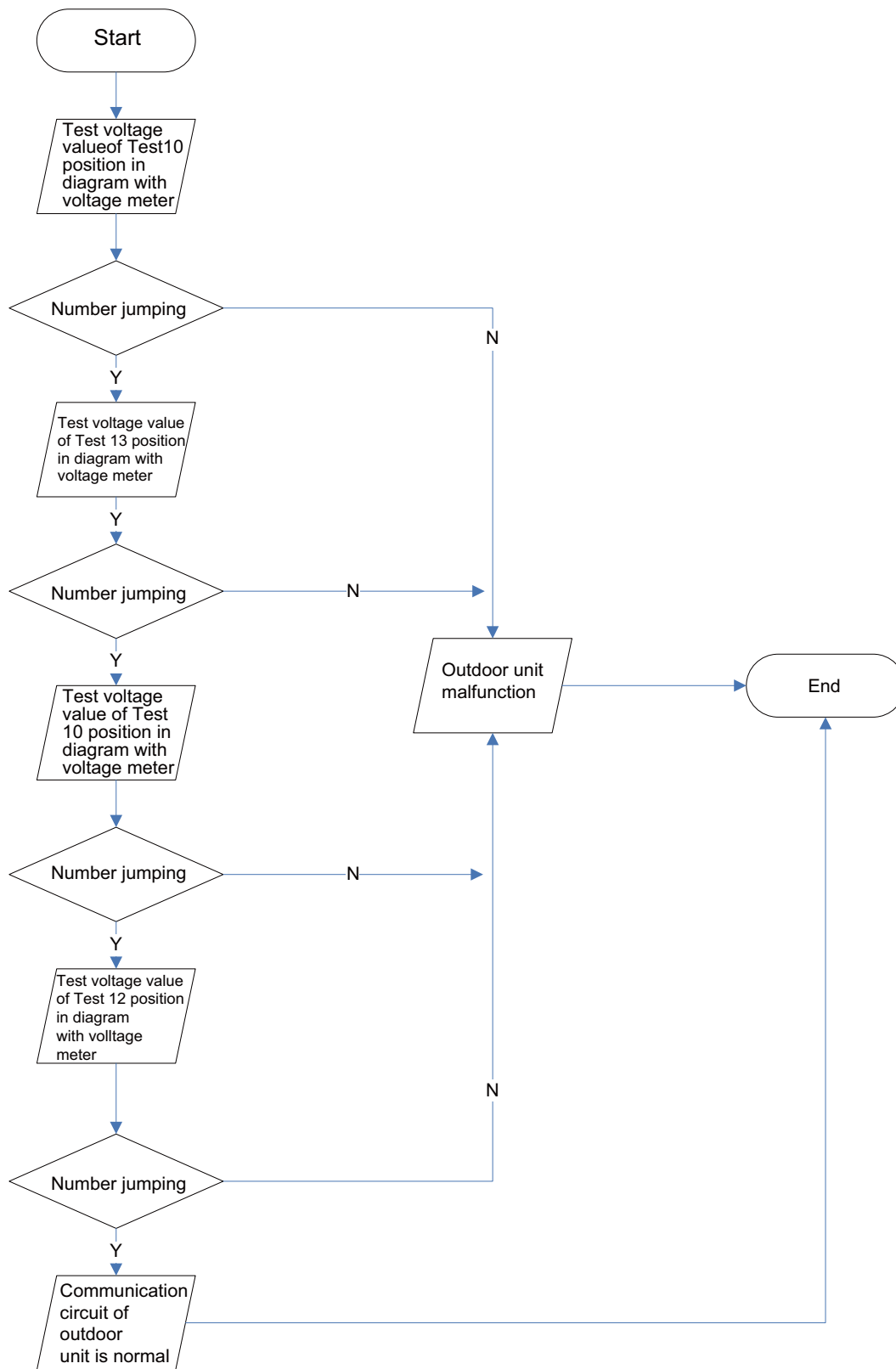

Appendix

Appendix 1: Resistance Table of Ambient Temperature Sensor for Indoor and Outdoor Units(15K)							
Temp.(°F)	Resistance(kΩ)	Temp.(°F)	Resistance(kΩ)	Temp.(°F)	Resistance(kΩ)	Temp.(°F)	Resistance(kΩ)
-2.2	138.1	68	18.75	138.2	3.848	208.4	1.071
-0.4	128.6	69.8	17.93	140	3.711	210.2	1.039
1.4	121.6	71.6	17.14	141.8	3.579	212	1.009
3.2	115	73.4	16.39	143.6	3.454	213.8	0.98
5	108.7	75.2	15.68	145.4	3.333	215.6	0.952
6.8	102.9	77	15	147.2	3.217	217.4	0.925
8.6	97.4	78.8	14.36	149	3.105	219.2	0.898
10.4	92.22	80.6	13.74	150.8	2.998	221	0.873
12.2	87.35	82.4	13.16	152.6	2.896	222.8	0.848
14	82.75	84.2	12.6	154.4	2.797	224.6	0.825
15.8	78.43	86	12.07	156.2	2.702	226.4	0.802
17.6	74.35	87.8	11.57	158	2.611	228.2	0.779
19.4	70.5	89.6	11.09	159.8	2.523	230	0.758
21.2	66.88	91.4	10.63	161.6	2.439	231.8	0.737
23	63.46	93.2	10.2	163.4	2.358	233.6	0.717
24.8	60.23	95	9.779	165.2	2.28	235.4	0.697
26.6	57.18	96.8	9.382	167	2.206	237.2	0.678
28.4	54.31	98.6	9.003	168.8	2.133	239	0.66
30.2	51.59	100.4	8.642	170.6	2.064	240.8	0.642
32	49.02	102.2	8.297	172.4	1.997	242.6	0.625
33.8	46.6	104	7.967	174.2	1.933	244.4	0.608
35.6	44.31	105.8	7.653	176	1.871	246.2	0.592
37.4	42.14	107.6	7.352	177.8	1.811	248	0.577
39.2	40.09	109.4	7.065	179.6	1.754	249.8	0.561
41	38.15	111.2	6.791	181.4	1.699	251.6	0.547
42.8	36.32	113	6.529	183.2	1.645	253.4	0.532
44.6	34.58	114.8	6.278	185	1.594	255.2	0.519
46.4	32.94	116.6	6.038	186.8	1.544	257	0.505
48.2	31.38	118.4	5.809	188.6	1.497	258.8	0.492
50	29.9	120.2	5.589	190.4	1.451	260.6	0.48
51.8	28.51	122	5.379	192.2	1.408	262.4	0.467
53.6	27.18	123.8	5.197	194	1.363	264.2	0.456
55.4	25.92	125.6	4.986	195.8	1.322	266	0.444
57.2	24.73	127.4	4.802	197.6	1.282	267.8	0.433
59	23.6	129.2	4.625	199.4	1.244	269.6	0.422
60.8	22.53	131	4.456	201.2	1.207	271.4	0.412
62.6	21.51	132.8	4.294	203	1.171	273.2	0.401
64.4	20.54	134.6	4.139	204.8	1.136	275	0.391
66.2	19.63	136.4	3.99	206.6	1.103	276.8	0.382

Appendix 2: Resistance Table of Outdoor and Indoor Tube Temperature Sensors(20K)							
Temp.(°F)	Resistance(kΩ)		Temp.(°F)	Resistance(kΩ)		Temp.(°F)	Resistance(kΩ)
-2.2	181.4		68	25.01		138.2	5.13
-0.4	171.4		69.8	23.9		140	4.948
1.4	162.1		71.6	22.85		141.8	4.773
3.2	153.3		73.4	21.85		143.6	4.605
5	145		75.2	20.9		145.4	4.443
6.8	137.2		77	20		147.2	4.289
8.6	129.9		78.8	19.14		149	4.14
10.4	123		80.6	18.13		150.8	3.998
12.2	116.5		82.4	17.55		152.6	3.861
14	110.3		84.2	16.8		154.4	3.729
15.8	104.6		86	16.1		156.2	3.603
17.6	99.13		87.8	15.43		158	3.481
19.4	94		89.6	14.79		159.8	3.364
21.2	89.17		91.4	14.18		161.6	3.252
23	84.61		93.2	13.59		163.4	3.144
24.8	80.31		95	13.04		165.2	3.04
26.6	76.24		96.8	12.51		167	2.94
28.4	72.41		98.6	12		168.8	2.844
30.2	68.79		100.4	11.52		170.6	2.752
32	65.37		102.2	11.06		172.4	2.663
33.8	62.13		104	10.62		174.2	2.577
35.6	59.08		105.8	10.2		176	2.495
37.4	56.19		107.6	9.803		177.8	2.415
39.2	53.46		109.4	9.42		179.6	2.339
41	50.87		111.2	9.054		181.4	2.265
42.8	48.42		113	8.705		183.2	2.194
44.6	46.11		114.8	8.37		185	2.125
46.4	43.92		116.6	8.051		186.8	2.059
48.2	41.84		118.4	7.745		188.6	1.996
50	39.87		120.2	7.453		190.4	1.934
51.8	38.01		122	7.173		192.2	1.875
53.6	36.24		123.8	6.905		194	1.818
55.4	34.57		125.6	6.648		195.8	1.736
57.2	32.98		127.4	6.403		197.6	1.71
59	31.47		129.2	6.167		199.4	1.658
60.8	30.04		131	5.942		201.2	1.609
62.6	28.68		132.8	5.726		203	1.561
64.4	27.39		134.6	5.519		204.8	1.515
66.2	26.17		136.4	5.32		206.6	1.47

Appendix 3: Resistance Table of Outdoor Discharge Temperature Sensor(50K)

Temp.(°F)	Resistance(kΩ)	Temp.(°F)	Resistance(kΩ)	Temp.(°F)	Resistance(kΩ)	Temp.(°F)	Resistance(kΩ)
-20.2	853.5	50	98	120.2	18.34	190.4	4.754
-18.4	799.8	51.8	93.42	122	17.65	192.2	4.609
-16.6	750	53.6	89.07	123.8	16.99	194	4.469
-14.8	703.8	55.4	84.95	125.6	16.36	195.8	4.334
-13	660.8	57.2	81.05	127.4	15.75	197.6	4.204
-11.2	620.8	59	77.35	129.2	15.17	199.4	4.079
-9.4	580.6	60.8	73.83	131	14.62	201.2	3.958
-7.6	548.9	62.6	70.5	132.8	14.09	203	3.841
-5.8	516.6	64.4	67.34	134.6	13.58	204.8	3.728
-4	486.5	66.2	64.33	136.4	13.09	206.6	3.619
-2.2	458.3	68	61.48	138.2	12.62	208.4	3.514
-0.4	432	69.8	58.77	140	12.17	210.2	3.413
1.4	407.4	71.6	56.19	141.8	11.74	212	3.315
3.2	384.5	73.4	53.74	143.6	11.32	213.8	3.22
5	362.9	75.2	51.41	145.4	10.93	215.6	3.129
6.8	342.8	77	49.19	147.2	10.54	217.4	3.04
8.6	323.9	78.8	47.08	149	10.18	219.2	2.955
10.4	306.2	80.6	45.07	150.8	9.827	221	2.872
12.2	289.6	82.4	43.16	152.6	9.489	222.8	2.792
14	274	84.2	41.34	154.4	9.165	224.6	2.715
15.8	259.3	86	39.61	156.2	8.854	226.4	2.64
17.6	245.6	87.8	37.96	158	8.555	228.2	2.568
19.4	232.6	89.6	36.38	159.8	8.268	230	2.498
21.2	220.5	91.4	34.88	161.6	7.991	231.8	2.431
23	209	93.2	33.45	163.4	7.726	233.6	2.365
24.8	198.3	95	32.09	165.2	7.47	235.4	2.302
26.6	199.1	96.8	30.79	167	7.224	237.2	2.241
28.4	178.5	98.6	29.54	168.8	6.998	239	2.182
30.2	169.5	100.4	28.36	170.6	6.761	240.8	2.124
32	161	102.2	27.23	172.4	6.542	242.6	2.069
33.8	153	104	26.15	174.2	6.331	244.4	2.015
35.6	145.4	105.8	25.11	176	6.129	246.2	1.963
37.4	138.3	107.6	24.13	177.8	5.933	248	1.912
39.2	131.5	109.4	23.19	179.6	5.746	249.8	1.863
41	125.1	111.2	22.29	181.4	5.565	251.6	1.816
42.8	119.1	113	21.43	183.2	5.39	253.4	1.77
44.6	113.4	114.8	20.6	185	5.222	255.2	1.725
46.4	108	116.6	19.81	186.8	5.06	257	1.682
48.2	102.8	118.4	19.06	188.6	4.904	258.8	1.64

Note: The information above is for reference only.

10. Removal Procedure

10.1 Removal Procedure of Indoor Unit



Warning

Be sure to wait for a minimum of 10 minutes after turning off all power supplies before disassembly.

NOTE:Take GWC09MB-D3DNA3D/I for example.

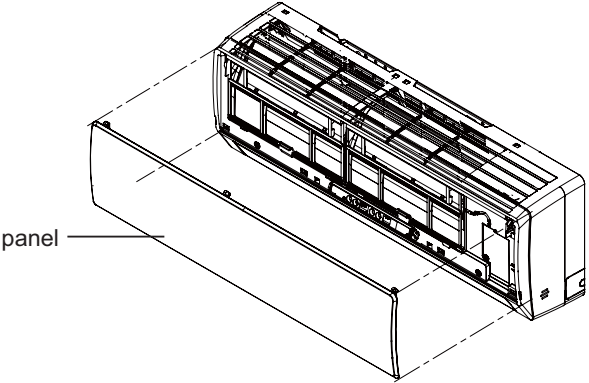
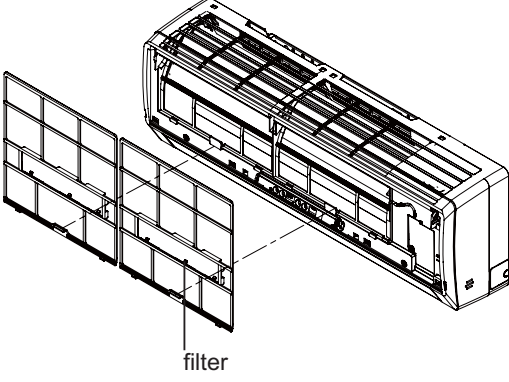
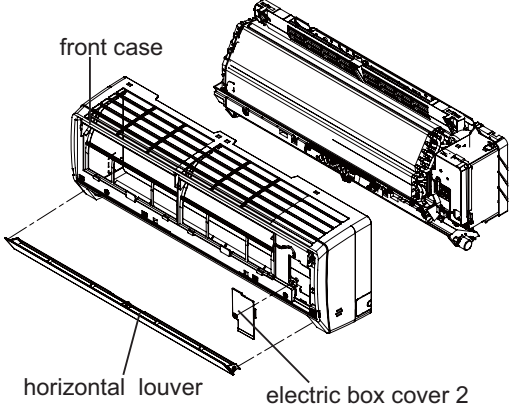
Steps	Procedure
1.Remove panel	<p>Open the front panel.Push the rotor shaft on both sides of the panel to make it separate from the groove .Remove the panel.</p>  <p>panel</p>
2.Remove filter	<p>Loosen the clasp of the filter.Push the filter inward and then draw it upward to remove it.</p>  <p>filter</p>
3.Remove horizontal louver and front case	<p>Remove axial sleeve of horizontal louver. Bend the louver outwards and then remove the louver.</p> <p>Loosen the screws of the electric box cover2 with screwdriver.Remove the electric box cover2.</p> <p>Open the screw cap on the front case. Remove the screws fixing the front case. Loosen the six clasps of the front case. Remove the front case.</p>  <p>front case</p> <p>horizontal louver</p> <p>electric box cover 2</p>

Removal Procedure

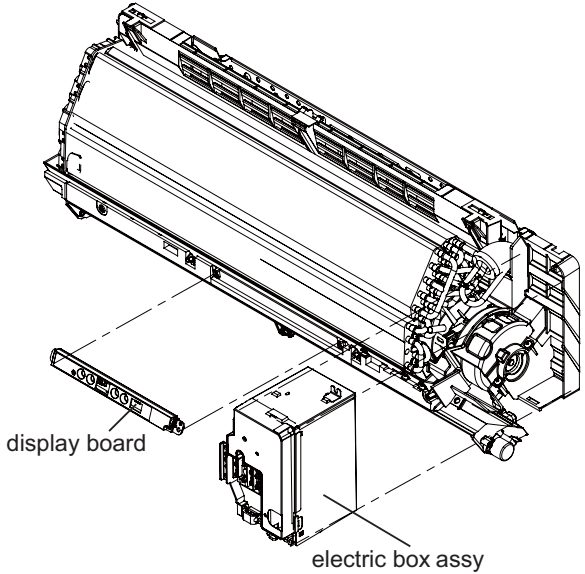
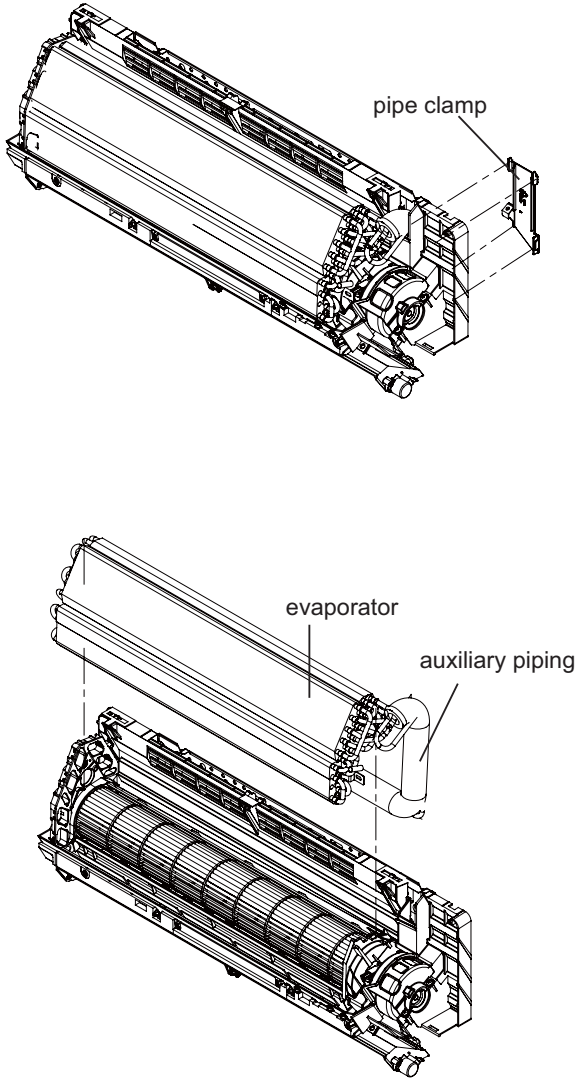
Steps	Procedure
4.Remove electric box assy	<p data-bbox="252 432 691 613">Remove the screws of the electric box assy.Remove the screws at the joint of the earthing wire and evaporator.Looseen the clasp at the joint of the electric box cover and the electric box.Remove the 2 screws of the display.Remove the electric box assy.</p> 
5.Remove evaporator	<p data-bbox="148 1106 683 1189">1 Remove the screws of the press plate of connecting pipe.Remove press plate of connecting pipe.</p>  <p data-bbox="148 1565 695 1671">2 Remove the 3 screws at the joint of the evaporator and rear case.Adjust slightly the pipe on the evaporator.Remove the evaporator.</p>

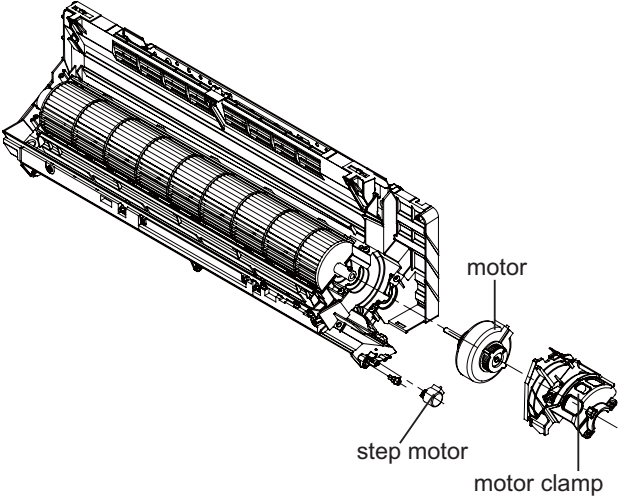
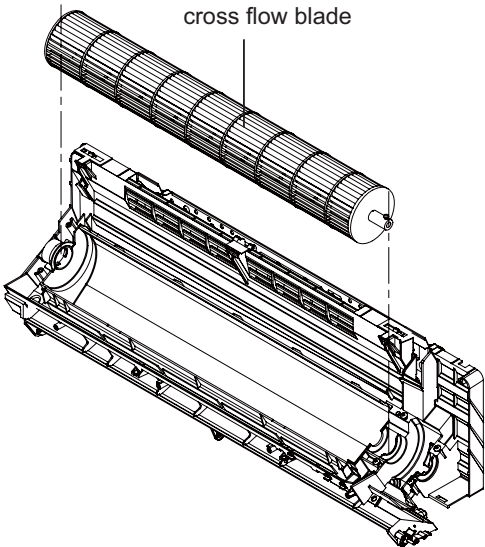
Steps	Procedure	Procedure
6.Remove motor and cross flow blade		
1	<p>Remove screws of step motor and then remove the motor.</p> <p>Remove the screw of the motor clamp and then remove the clamp.</p> <p>Remove the screws at the joint of the cross flow blade and the motor. Take down the motor.</p>	 <p>motor</p> <p>step motor</p> <p>motor clamp</p>
2	<p>Remove the cross flow blade.</p>	 <p>cross flow blade</p>

10.2 Removal Procedure of Outdoor Unit(09K)



Warning

Be sure to wait for a minimum of 10 minutes after turning off all power supplies before disassembly.

NOTE:Take heat models without electric heating belt for example.

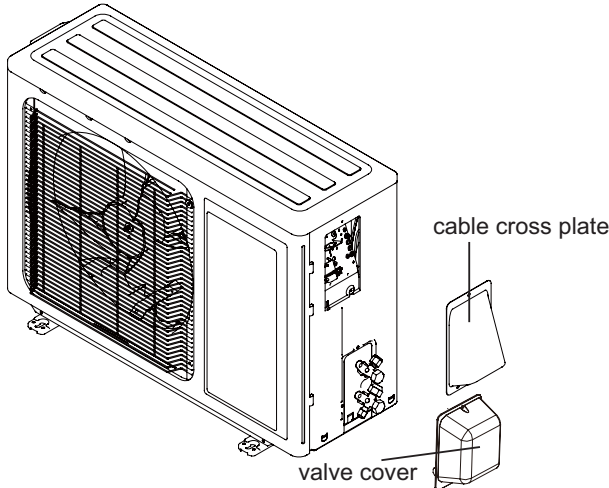
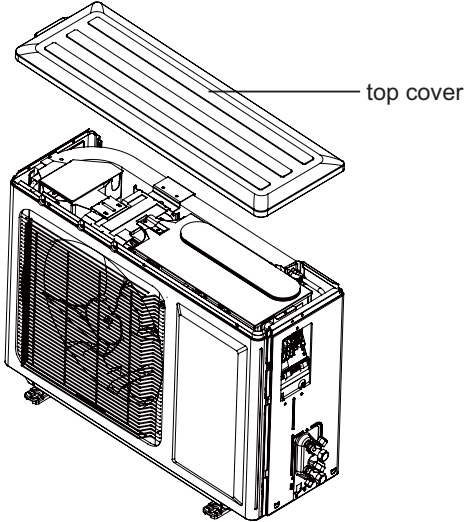
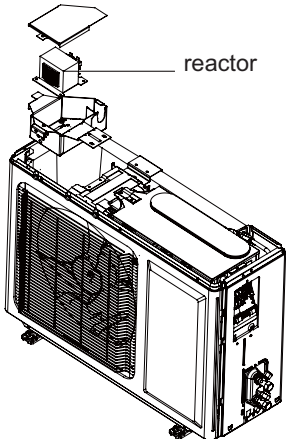
Steps	Procedure
<p>1.Remove cable cross plate and valve cover</p>	<p>Remove connection screw fixing cable cross plate and valve cover then remove them.</p> 
<p>2.Remove top cover</p>	<p>Remove connection screws connecting the top cover plate with the front panel and the right side plate,and then remove the top cover.</p> 
<p>3.Remove reactor sub-assy</p>	<p>Remove screws fixing reactor sub-assy, and then pull the reactor sub-assy upwards to remove it. Remove screws on reactor sub-assy cover, and then remove the reactor.</p> 

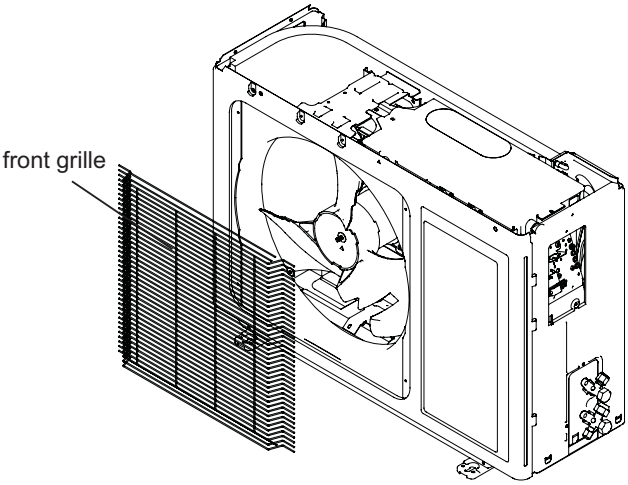
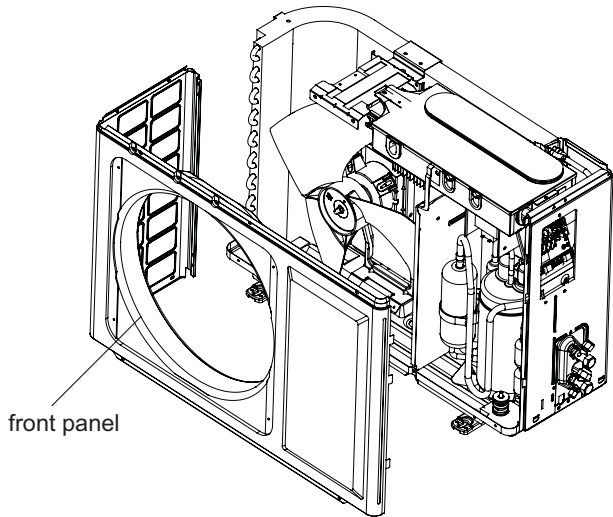
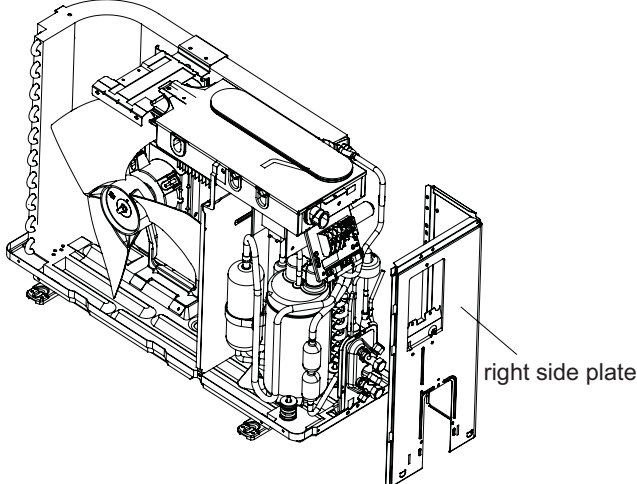
Steps	Procedure
<p>4.Remove front grille</p>	<p>Remove connection screws between the front grille and the front panel. Then remove the front grille.</p>  <p>The diagram shows a perspective view of the front of the unit. A label 'front grille' points to the grille being detached from the front panel. The internal components like the fan and motor are visible through the opening.</p>
<p>5.Remove front panel</p>	<p>Remove connection screws connecting the front panel with the chassis and the motor support, and then remove the front panel.</p>  <p>The diagram shows the front panel being lifted away from the main chassis. A label 'front panel' points to the detached panel. The internal fan and motor assembly are now more clearly visible.</p>
<p>6.Remove right side plate</p>	<p>Remove connection screws connecting the right side plate with the valve support and the electric box. Then remove the right side plate.</p>  <p>The diagram shows the right side plate being detached from the main unit. A label 'right side plate' points to the removed plate. The internal valve support and electric box are visible.</p>

Removal Procedure

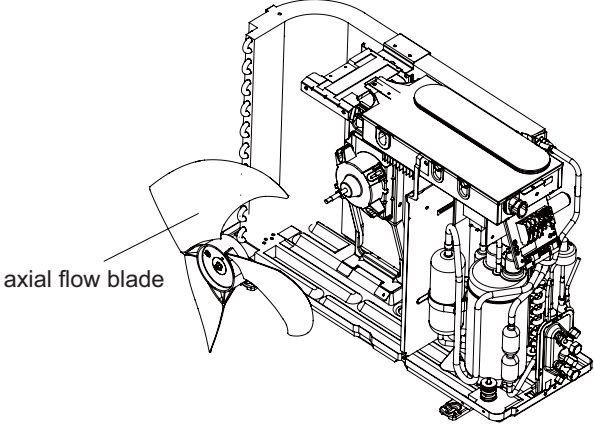
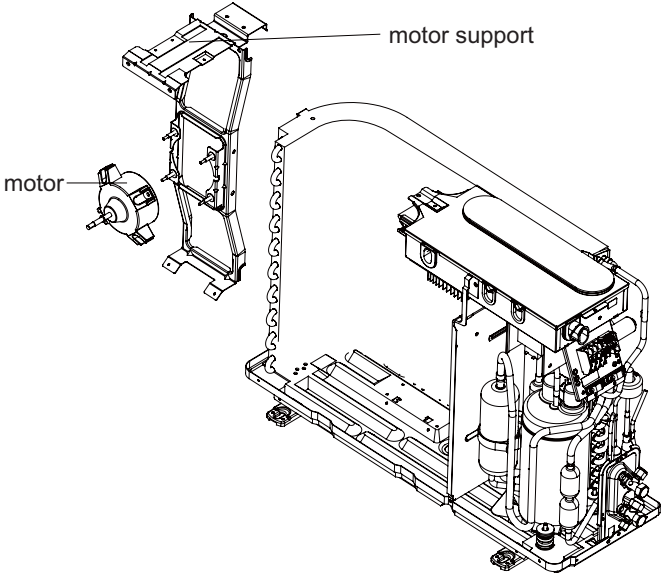
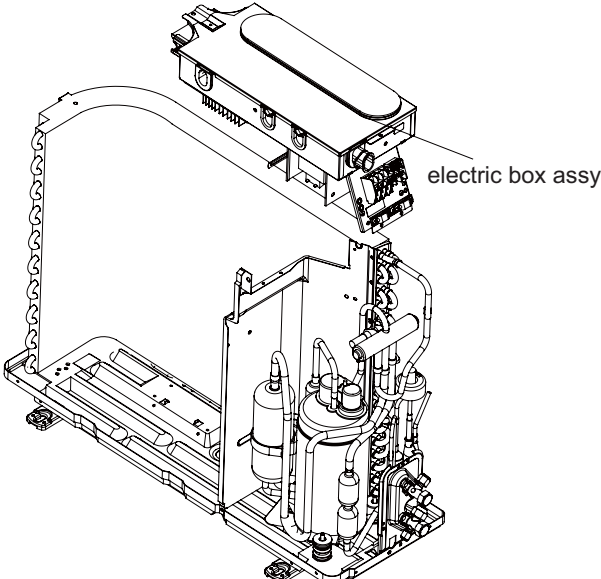
Steps	Procedure
7.Remove axial flow blade	<p data-bbox="233 421 667 472">Remove the nut fixing the blade and then remove the axial flow blade.</p>  <p data-bbox="762 555 927 584">axial flow blade</p> <p>The diagram shows a side view of the engine assembly with the axial flow blade highlighted. A callout line points to the blade, which is a curved, fan-like component mounted on a central shaft.</p>
8.Remove motor and motor support	<p data-bbox="233 958 730 1070">Remove the 4 tapping screws fixing the motor. Pull out the lead-out wire and remove the motor. Remove the 2 tapping screws fixing the motor support. Lift motor support to re-move it.</p>  <p data-bbox="1150 815 1299 844">motor support</p> <p data-bbox="762 965 826 994">motor</p> <p>The diagram shows the engine assembly with the motor and motor support removed. The motor support is a metal frame that holds the motor. The motor is a small, cylindrical component. Callout lines point to the motor support and the motor.</p>
9.Remove electric box assy	<p data-bbox="233 1637 703 1749">Remove the 2 screws fixing the cover of electric box. Lift to remove the cover. Loosen the wire and disconnect the terminal. Lift to remove the electric box assy.</p>  <p data-bbox="1257 1608 1434 1637">electric box assy</p> <p>The diagram shows the engine assembly with the electric box assembly removed. The electric box assembly is a rectangular metal box that houses the electrical components. A callout line points to the electric box assembly.</p>

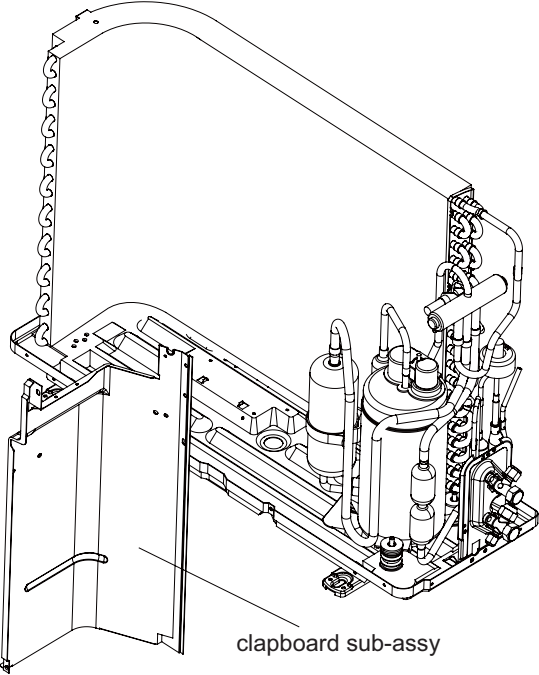
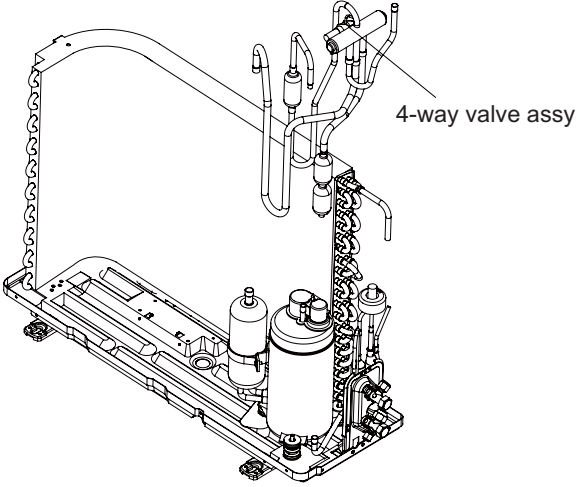
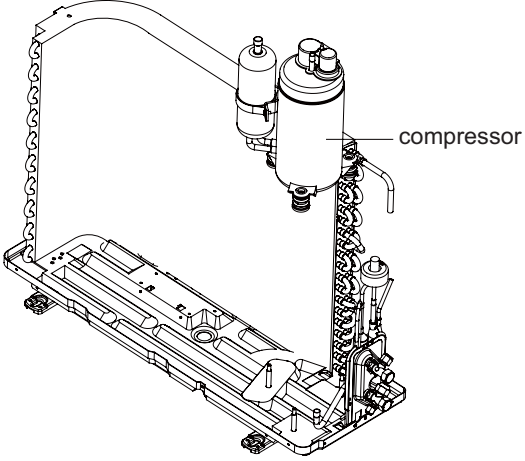
Steps	Procedure
10.Remove clapboard sub-assy	<p data-bbox="228 450 724 555">Loosen the screws of the clapboard sub-assy . The clapboard sub-assy has a hook on the lower side. Lift and pull the clapboard sub-assy to remove.</p> 
11.Remove 4-way valve assy	<p data-bbox="228 1133 724 1384">Unscrew the fastening nut of the 4-way valve assy coil and remove the coil. Wrap the 4-way valve assy with wet cotton and unsolder the 4 weld spots connecting the 4-way valve assy to take it out(Note: Refrigerant should be discharged firstly.) Welding process should be as quickly as possible and keep wrapping cotton wet all the time. Be sure not to burn out the lead-out wire of compressor.</p> 
12.Remove compressor	<p data-bbox="228 1700 724 1756">Remove the 3 footing screws of the compressor and remove the compressor.</p> 

10.3 Removal Procedure of Outdoor Unit(12K)



Warning

Be sure to wait for a minimum of 10 minutes after turning off all power supplies before disassembly.

NOTE:Take heat models without electric heating belt for example.

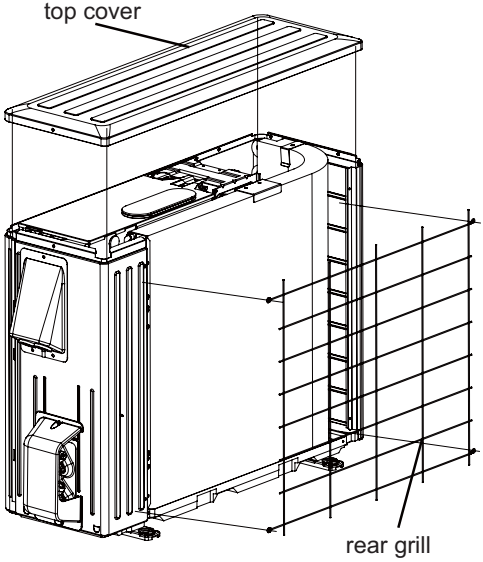
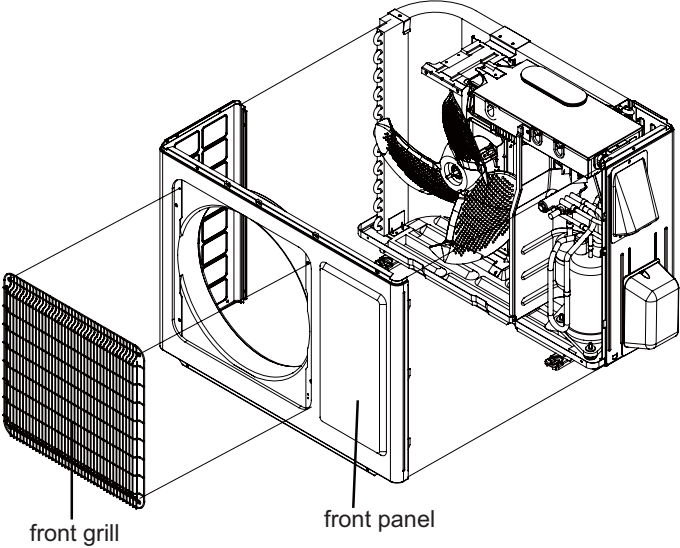
Steps	Procedure
<p>1.Remove top cover and rear grill</p>	<p>Twist off the screws used for fixing the top cover, pull the top cover upward to remove it. Twist off the screws used for fixing the rear grill, pull the rear grill upward to remove it.</p>  <p>Labels: top cover, rear grill</p>
<p>2.Remove front grill and front panel</p>	<p>Remove the screws connecting the front grill and the front panel. Remove the front grill. Remove the screws fixing the panel, pull it upward, loosen the clasp on the right side, rotate it to the left and then remove the front panel.</p>  <p>Labels: front grill, front panel</p>

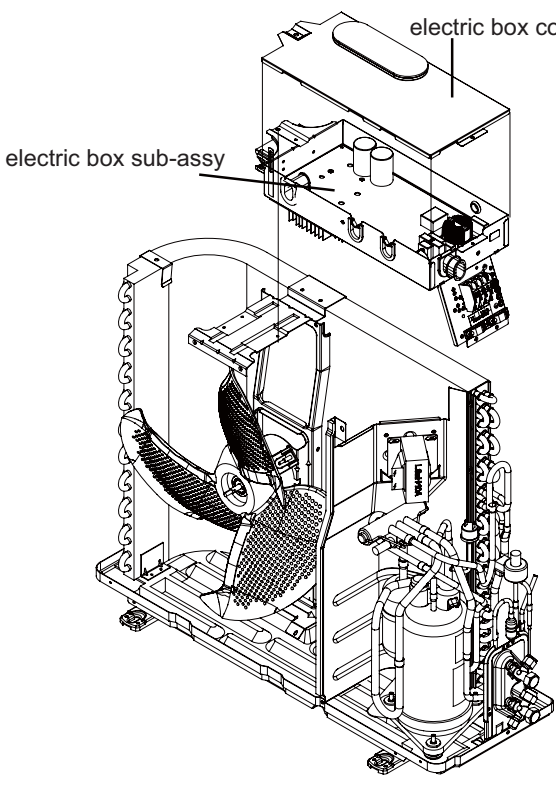
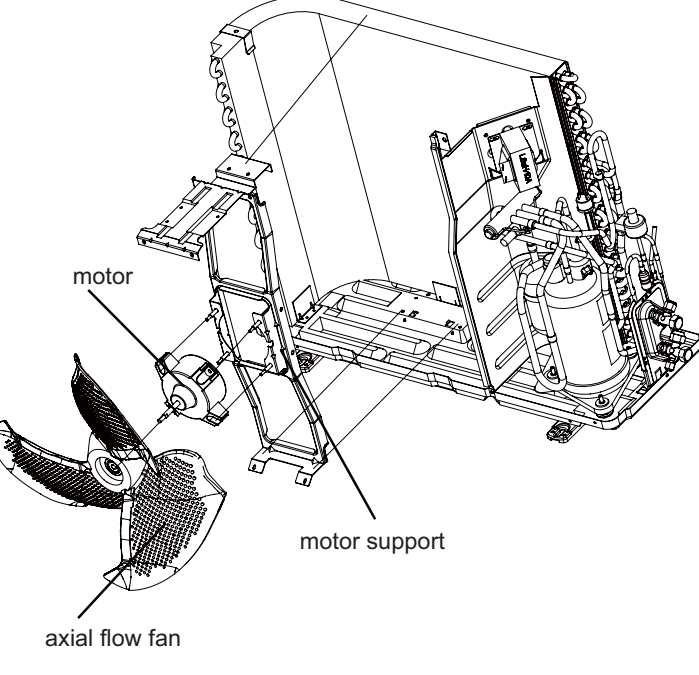
Steps	Procedure	
3.Remove electric box sub-assy	<p>Remove the screw connecting the electric box cover with electric box, and then remove electric box cover. Remove the screws fixing the electric box sub-assy; loosen the wire bundle; pull out the wiring terminals and then pull the electric box upwards to remove it.</p>	
4.Remove the axial flow fan and motor	<p>1 Remove the nuts fixing the blade and then remove the axial flow fan.</p> <p>2 Remove the 4 tapping screws fixing the motor; disconnect the leading wire insert of the motor and then remove the motor. Remove the 2 tapping screws fixing the motor support and then pull the motor support upwards to remove it.</p>	

Removal Procedure

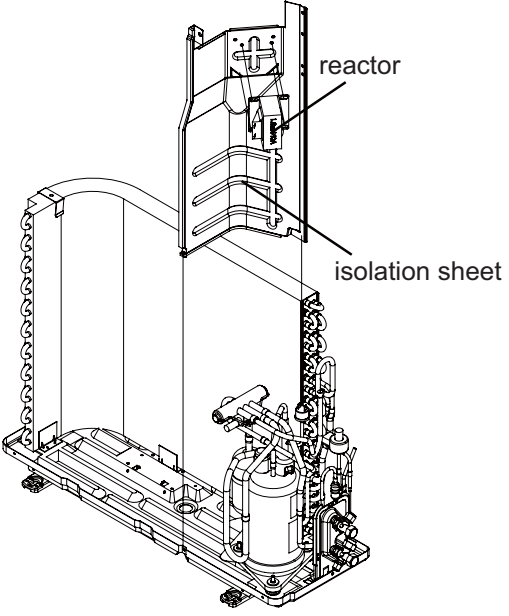
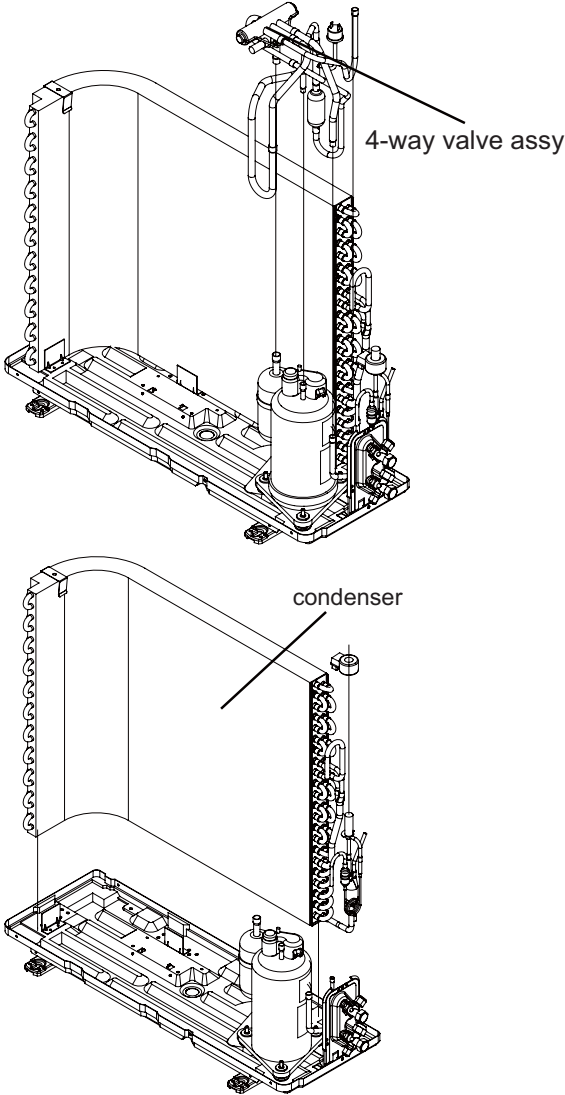
Steps	Procedure	
5.Remove the reactor and isolation sheet	Remove screws fixing reactor and then remove the reactor. Remove screws fixing isolation sheet and then remove the isolation sheet.	 <p>The diagram shows a side view of the chassis with the reactor and isolation sheet highlighted. The reactor is a vertical assembly at the top, and the isolation sheet is a large rectangular panel below it. Labels 'reactor' and 'isolation sheet' point to their respective parts.</p>
6.Remove 4-way valve assy and condenser	Discharge the refrigerant completely;unsolder the pipeline connecting the compressor and the condenser assy,and then remove the 4-way valve assy. Remov screws between condenser and chassis-sub-assy.Then remove condenser.	 <p>The diagram shows two stages of removal. The top part shows the 4-way valve assembly being removed from the top of the chassis, with a label '4-way valve assy'. The bottom part shows the condenser being removed from the side of the chassis, with a label 'condenser'.</p>

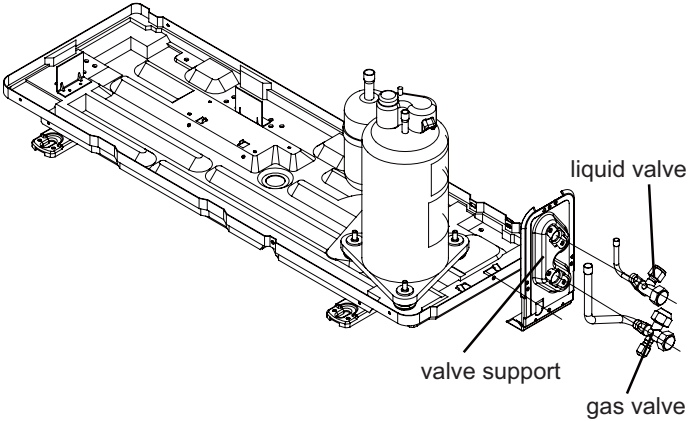
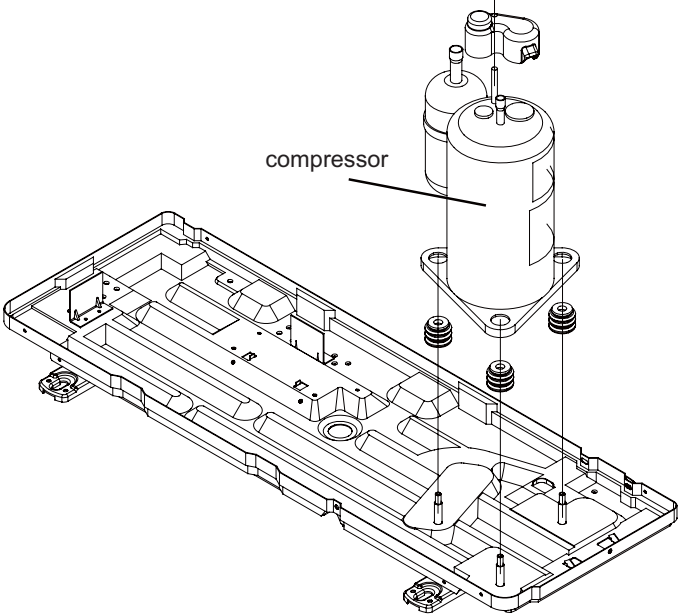
Steps	Procedure
7.Remove the gas valve, liquid valve and valve support	<p>Remove the screws fixing the gas valve and unsolder the welding joint between the gas valve and the air-return pipe to remove the gas valve. (NOTE: Discharge the refrigerant completely before unsoldering; When unsoldering, wrap the gas valve with a wet cloth completely to avoid damage to the valve caused by high temperature). Remove the screws fixing the liquid valve and unsolder the welding joint connecting the liquid valve to the Y-type pipe to remove the liquid valve. Remove the screws fixing the valve support with the chassis sub-assy, then remove the valve support.</p> 
8.Remove compressor	<p>Twist off the three foot nuts on compressor and then remove the compressor.</p> 

10.4 Removal Procedure of Outdoor Unit(18K)



Warning

Be sure to wait for a minimum of 10 minutes after turning off all power supplies before disassembly.

NOTE:Take heat model without electric heating belt for example.

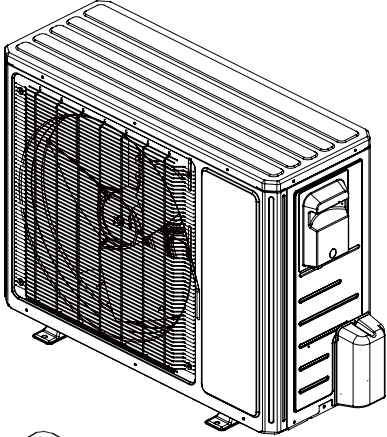
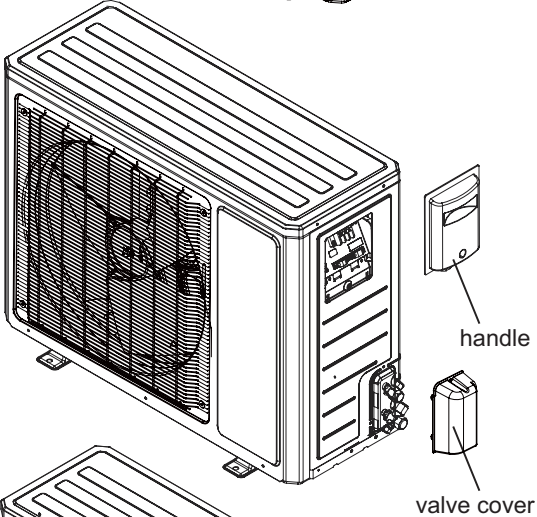
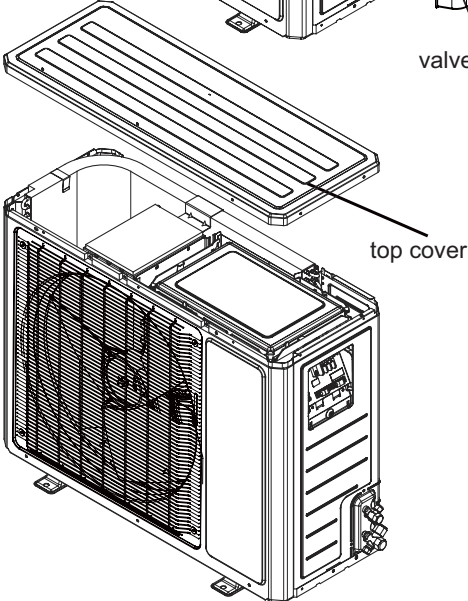
Steps	Procedure	
1. Remove top cover and handle		
1	Before disassembly.	
2	Twist off the screws used for fixing the handle, pull the handle upward to remove it. Loosen the screws fixing the valve cover and then remove the valve cover.	 <p style="text-align: right;">handle valve cover</p>
3	Twist off the screws used for fixing the top cover, pull the top cover upward to remove it.	 <p style="text-align: right;">top cover</p>

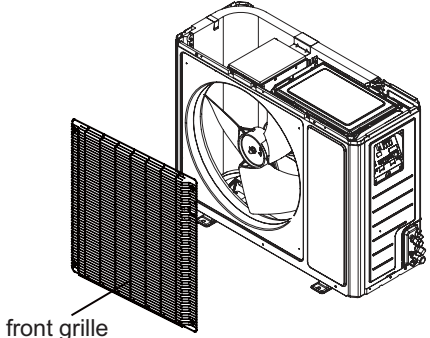
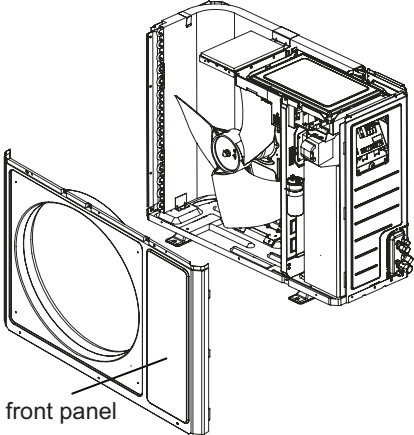
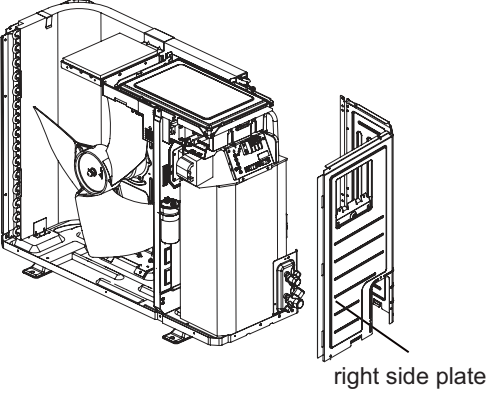
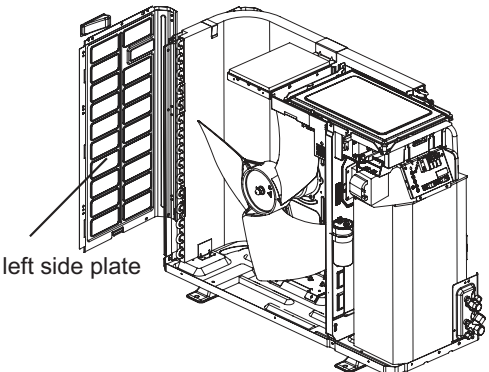
Steps	Procedure	
2.Remove front grille and front panel		
1	Remove the screws connecting the front grille and the front panel. Remove the front grille.	 <p>front grille</p>
2	Twist off the screws fixing the panel, pull it upward, loosen the clasp on the right side, rotate it to the left and then remove the front panel.	 <p>front panel</p>
3.Remove right&left side plate		
1	Remove the screws connecting the right side plate with the chassis,the valve support and the electric box, and then remove the right side plate assy.	 <p>right side plate</p>
2	Remove the screws connecting the left side plate and the chassis, and then remove the left side plate assy.	 <p>left side plate</p>

Removal Procedure

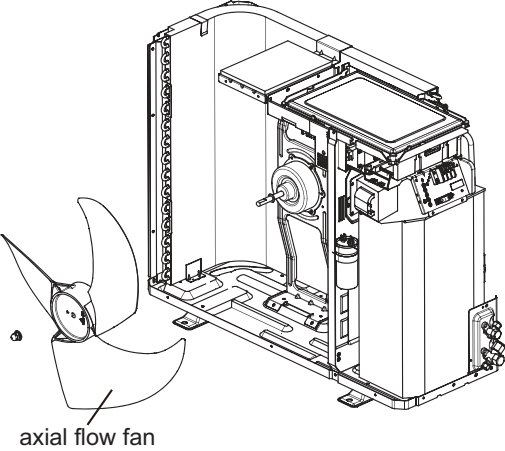
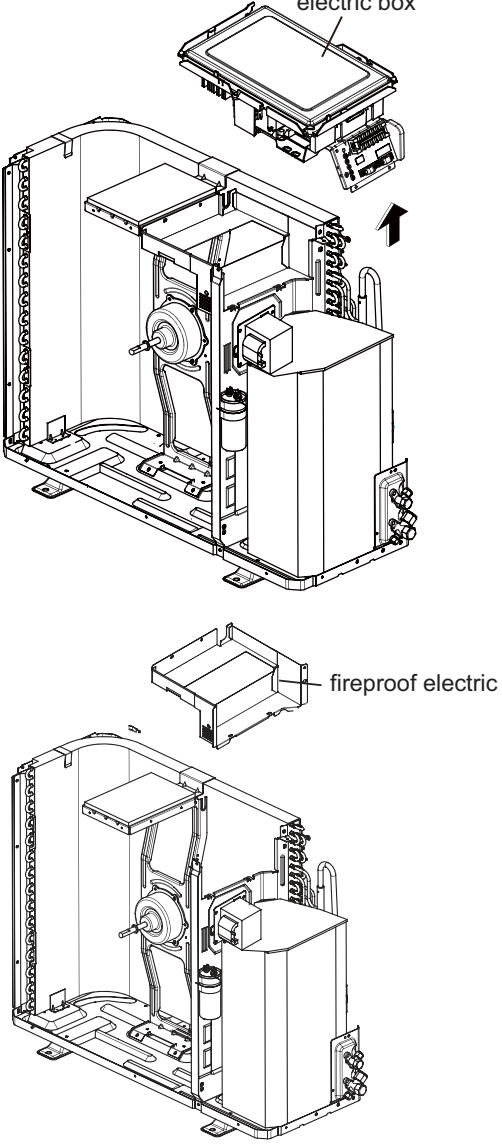
Steps	Procedure
4. Remove axial flow fan	<p data-bbox="201 421 775 477">Remove the nuts fixing the blade and then remove the axial flow fan.</p> 
5. Remove electric box and fireproof electric	<p data-bbox="129 1077 746 1160">1 Remove the screws fixing the electric box sub-assy; loosen the wire bundle; pull out the wiring terminals and then pull the electric box upwards to remove it.</p>  <p data-bbox="129 1675 711 1731">2 Twist off the screws on fireproof electric box and then remove the fireproof electric box.</p>

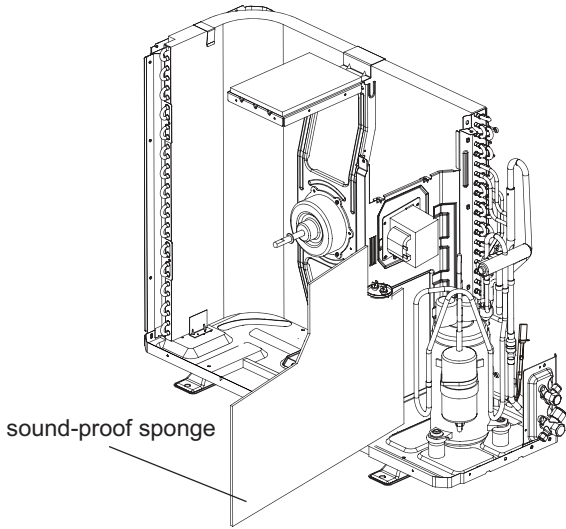
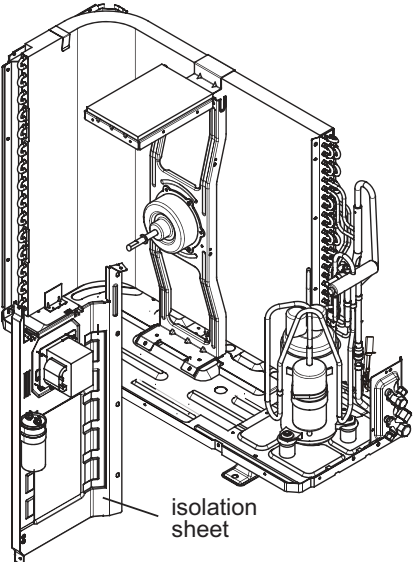
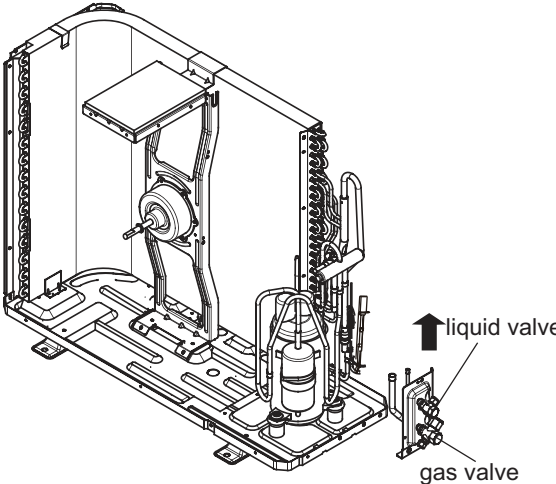
Steps	Procedure
6.Remove sound-proof sponge	<p data-bbox="193 421 671 472">Remove the soundproof sponge wrapping the compressor.</p>  <p data-bbox="831 703 1046 734">sound-proof sponge</p>
7.Remove isolation sheet	<p data-bbox="193 1077 671 1128">Remove screws fixing isolation sheet and then remove the isolation sheet.</p>  <p data-bbox="1182 1357 1270 1388">isolation sheet</p>
8.Remove gas valve and liquid valve	<p data-bbox="193 1626 743 1872">Twist off the 2 bolts fixing the valve sub-assy. Unsolder the soldering joint between gas valve and air-return pipe and then remove the gas valve. (note: when unsoldering the soldering joint, wrap the gas valve with wet cloth completely to avoid the damage to valve, and release all refrigerant completely at first). Unsolder the soldering joint between liquid valve and connection pipe of liquid valve, and then remove the liquid valve.</p>  <p data-bbox="1358 1805 1509 1827">↑ liquid valve</p> <p data-bbox="1358 1951 1461 1973">gas valve</p>

Removal Procedure

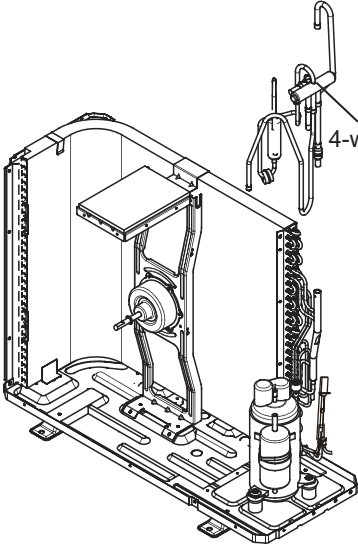
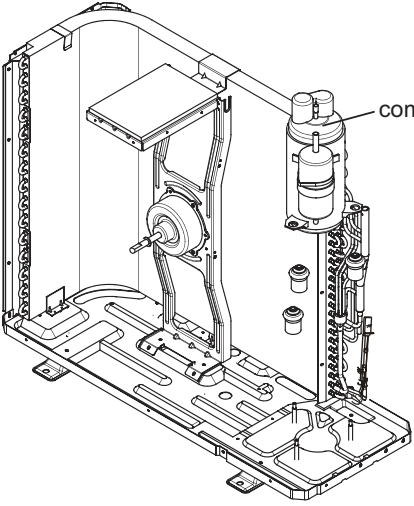
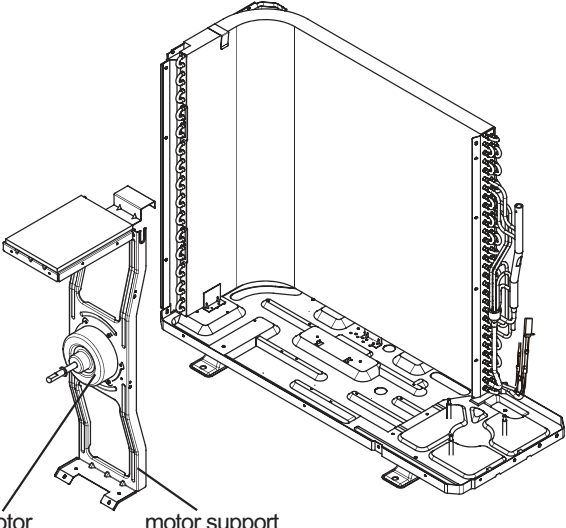
Steps	Procedure	
9.Remove 4-way valve	<p>Discharge the refrigerant completely;unsolder the pipeline connecting the compressor and the condenser assy,and then remove the 4-way valve.</p>	 <p>A technical line drawing showing a 4-way valve assembly mounted on a refrigeration unit chassis. The valve is connected to various pipes and components. A label '4-way valve' with a leader line points to the valve assembly.</p>
10.Remove compressor	<p>Twist off the three foot nuts on compressor and then remove the compressor.</p>	 <p>A technical line drawing showing a compressor assembly mounted on a refrigeration unit chassis. The compressor is connected to various pipes and components. A label 'compressor' with a leader line points to the compressor assembly.</p>
11.Remove motor and motor support	<p>Remove the 4 tapping screws fixing the motor; disconnect the leading wire insert of the motor and then remove the motor. Remove the 2 tapping screws fixing the motor support and then pull the motor support upwards to remove it.</p>	 <p>A technical line drawing showing a motor and motor support assembly mounted on a refrigeration unit chassis. The motor is connected to various pipes and components. Labels 'motor' and 'motor support' with leader lines point to the respective parts.</p>

10.5 Removal Procedure of Outdoor Unit(24K)



Warning

Be sure to wait for a minimum of 10 minutes after turning off all power supplies before disassembly.

NOTE:Take heat model without electric heating belt for example.

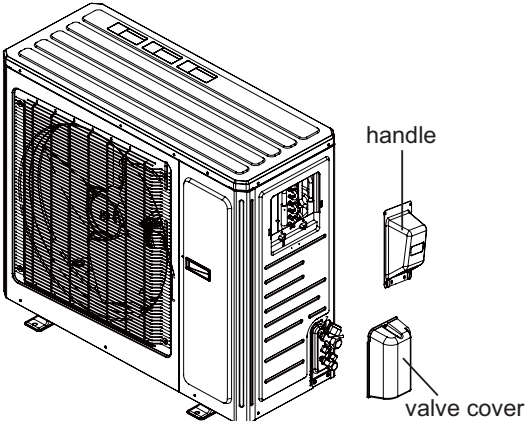
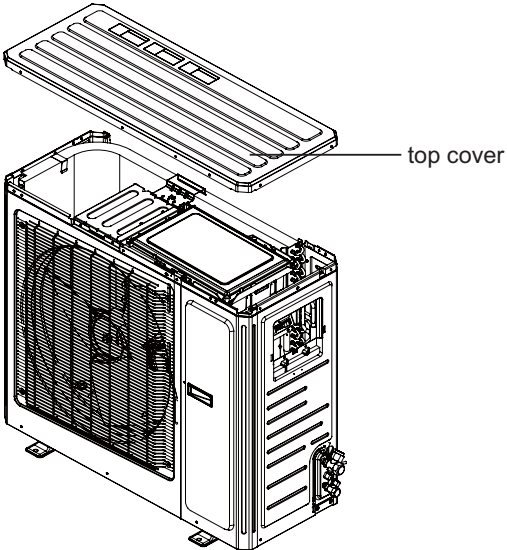
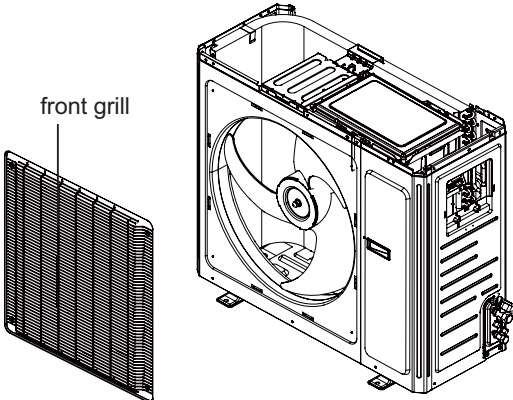
Steps	Procedure	
1.Remove handle and valve cover	Twist off the screws used for fixing the handle, pull the handle upward to remove it.Looseen the screws fixing the valve cover and then remove it.	
2.Remove top cover	Remove connection screws connecting the top cover plate with the front panel and the right side plate,and then remove the top cover.	
3.Remove front grill	Remove the screws connecting the front grill and the front panel. Remove the front grill.	

Steps	Procedure
4.Remove front side plate and front panel	<div data-bbox="938 286 1348 891"> </div> <div data-bbox="801 913 1481 1413"> </div>
5.Remove right side plate	<div data-bbox="874 1429 1449 2016"> </div>

Steps	Procedure
4.Remove front side plate and front panel	<div data-bbox="938 286 1348 891"> </div> <div data-bbox="801 913 1481 1413"> </div>
5.Remove right side plate	<div data-bbox="874 1429 1453 2016"> </div>

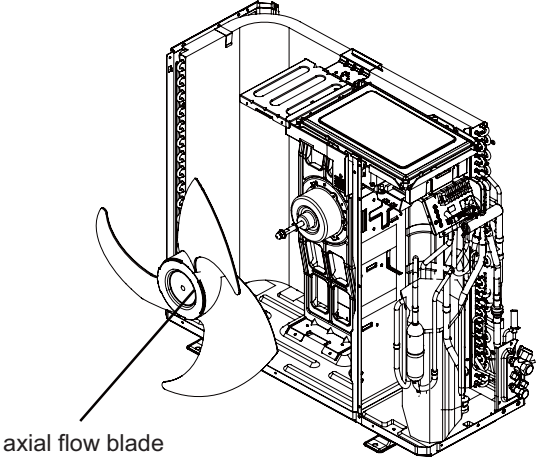
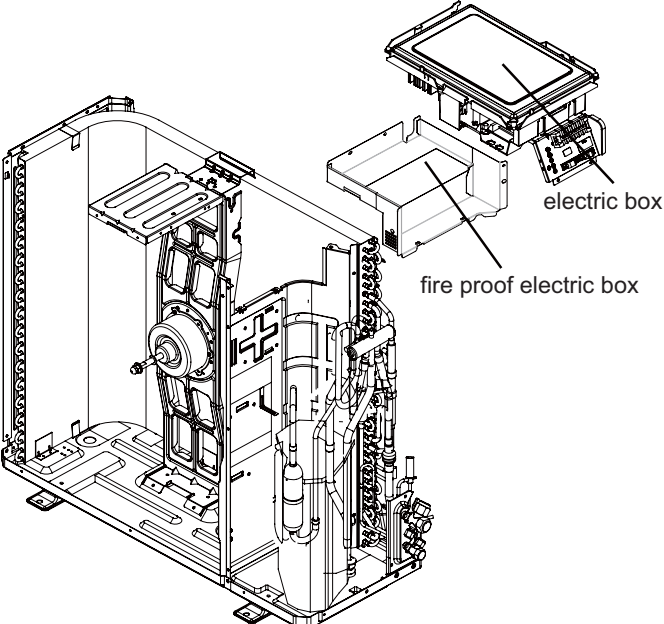
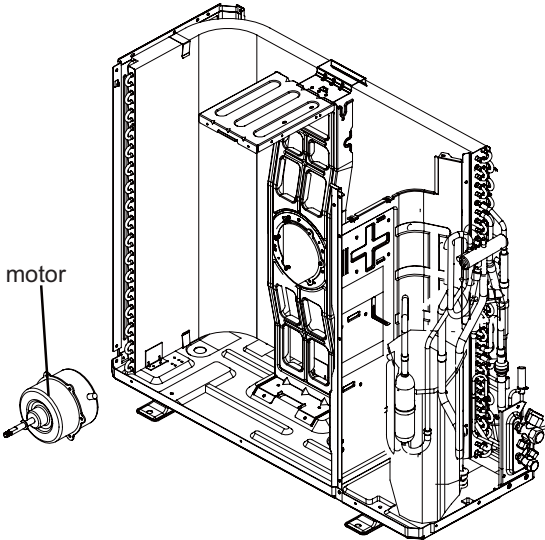
Steps	Procedure	
6.Remove axial flow blade	Remove nut on blade with wrench,and then remove the axial flow blade.	 <p>axial flow blade</p>
7.Remove electric box and fireproof electric box	Remove screws fixing electric box,cut off the tielen with scissors, pull out the wiring terminal and then lift up the electric box to remove it. Twist off the screws on fireproof electric box and then remove the fireproof electric box.	 <p>electric box</p> <p>fire proof electric box</p>
8.Remove motor and motor support	1 Twist off the tapping screws fixingthe motor, pull out the pin of leading wire for motor and then remove the motor.	 <p>motor</p>

Removal Procedure

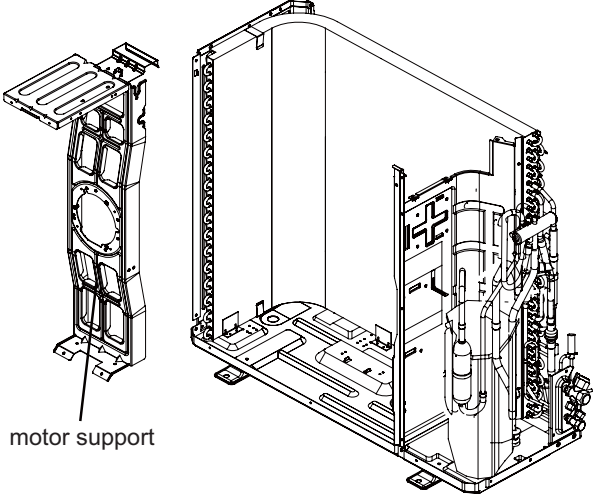
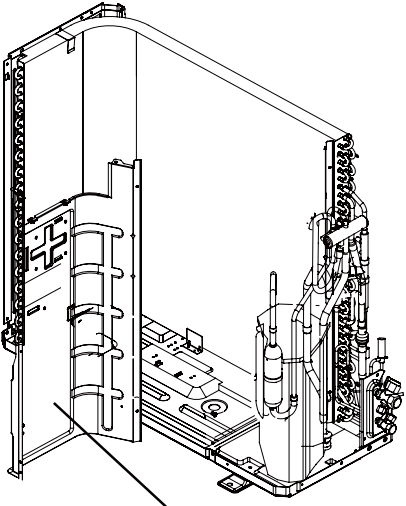
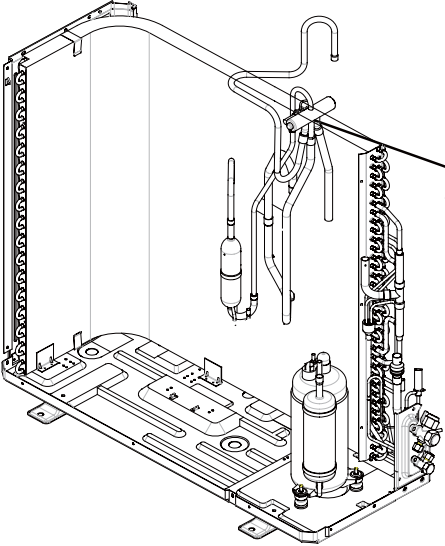
Steps	Procedure	
2	Twist off the tapping screws fixing the motor support, pull it upwards and then remove the motor support.	 <p>motor support</p>
9.Remove isolation sheet	Twist off the screws connecting isolation sheet and end plate of condenser and chassis, and then remove the isolation sheet.	 <p>isolation sheet</p>
10.Remove 4-way valve	Unsolder the pipe line between compressor, condenser, gas and liquid valve, and then remove the 4-way valve. (note: release all refrigerant before unsoldering).	 <p>4-way valve</p>

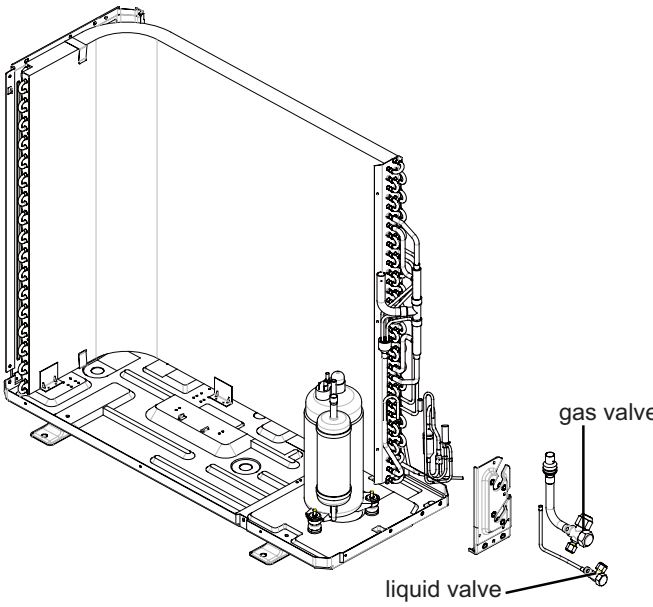
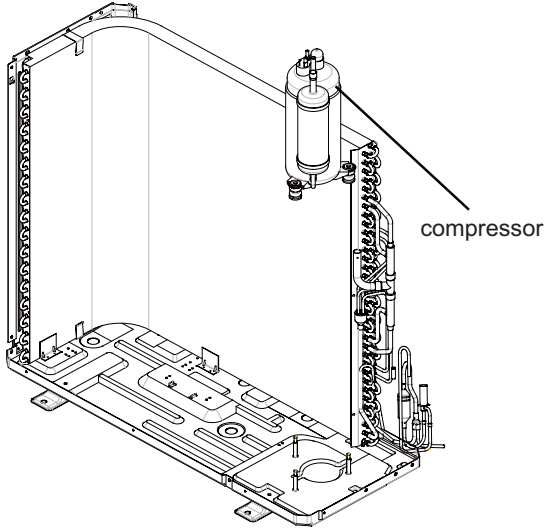
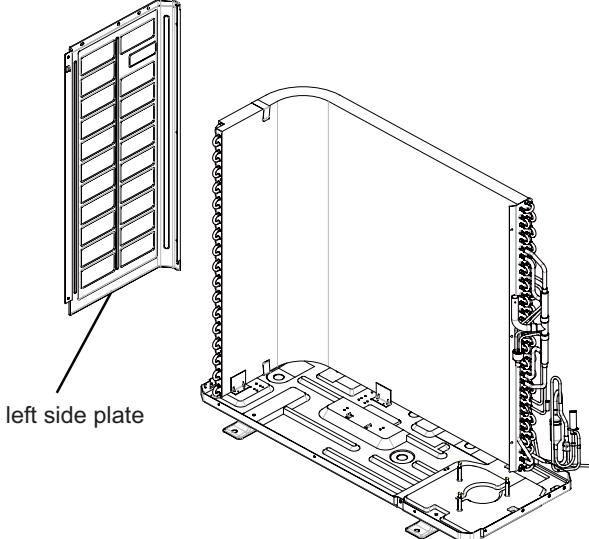
Steps	Procedure
<p>11.Remove gas valve and liquid valve</p>	<p>Twist off the 2 bolts fixing the valve sub-assy. Unsolder the soldering joint between gas valve and air-return pipe and then remove the gas valve. (note: when unsoldering the soldering joint, wrap the gas valve with wet cloth completely to avoid the damage to valve, and release all refrigerant completely at first). Unsolder the soldering joint between liquid valve and connection pipe of liquid valve, and then remove the liquid valve.</p>  <p>gas valve</p> <p>liquid valve</p>
<p>12.Remove compressor</p>	<p>Twist off the 3 foot nuts on compressor and then remove the compressor.</p>  <p>compressor</p>
<p>13.Remove left side plate</p>	<p>Twist off the screws connecting the left side plate and chassis with screwdriver, and then remove the left side plate.</p>  <p>left side plate</p>

JF00301520

GREE ELECTRIC APPLIANCES, INC. OF ZHUHAI

Add: West Jinji Rd, Qianshan, Zhuhai, Guangdong, China, 519070

Tel: (+86-756) 8522218 Fax: (+86-756) 8669426

E-mail: gree@gree.com.cn www.gree.com

For continuous improvement in the products, Gree reserves the right to modify the product specification and appearance in this manual without notice and without incurring any obligations.