



Turn to the experts

## Product Data

### Packaged Rooftop Electric Cooling Units

47.8 to 83.8 kW (14 to 25 Nominal Tons)



WeatherMaker 50TC17-30 Cooling Only/Electric Heat Packaged Rooftop, 50 Hz

**Your Carrier WeatherMaker 50TC-D17-30 rooftop unit (RTU) was designed by customers for customers. With a newly designed cabinet that integrates “no-strip screw” collars, handled access panels, and more, we’ve made your unit easy to install, easy to maintain and easy to use and reliable.**

- Two-stage cooling capacity with independent circuits and control.
- High performance copper tube/aluminum plate fin (RTPF) condenser and evaporator coils with optional coating.
- EERs up to 11.64.
- IPLVs up to 13.0.
- Dedicated vertical and horizontal air flow duct configuration models. No field kits required.
- Utility connections through the side or bottom. Bottom connections are also in an enclosed environment to help prevent water entry.
- Standardized components and control box layout. Standardized components and controls make stocking parts and service easier.
- Scroll compressors on all units. This makes service, stocking parts, replacement, and troubleshooting easier.
- Proven Acutrol refrigerant metering system.
- Easy-adjust, belt-drive motor available. Carrier provides a factory solution for most points in the fan performance table.

- Motor assembly also contains a fan belt break protection system on all models and reliable pillow block bearing system that allows lubrication thru front of the unit.
- Capable of thru-the-base or thru-the-curb electrical routing.
- Full range of electric heaters and single point electric kits – pre engineered and approved for field installation.
- Single-point electrical connection.
- Sloped, composite drain pan. Sloped, composite drain pan sheds water; and won't rust.
- Standardized controls and control box layout. Standardized components and controls make stocking parts and service easier. Clean, easy to use control box.
- Color-coded wiring.
- Large, laminated wiring and power wiring drawings which are affixed to unit make troubleshooting easy.
- Single, central terminal board for test and wiring connections.
- Fast-access, handled, panels for easy access on normally accessed service panels.
- “No-strip” screw system guides screws into the panel and captures them tightly without stripping the screw, the panel, or the unit.
- Mechanical cooling 52°C to 4°C (125°F to 40°F) on Direct Digital Controller (DDC) (PremierLink or RTU Open controller).
- Mechanical cooling 52°C to 4°C (125°F to 40°F) on Electro-Mechanical (E/M) models.
- 51mm (2-in.) disposable filters on all units, with 102mm (4-in.) filter track - field installed.

- Refrigerant filter-drier on each circuit.
- High and low pressure switches. Added reliability with high pressure switch and low pressure switch.
- Many factory-installed options ranging from air management economizers, 2 position dampers, manual outdoor air dampers, disconnect switch and smoke detectors.

### Easy to install:

These new WeatherMaker units are designed for dedicated factory supplied vertical or horizontal air flow duct configurations. No special field kits are required. Designed to fit on pre-installed curbs by other another manufacturer, these units also fit on past designed Carrier installed curbs with a new certified and authorized adapter curb. This new cabinet design also integrates a large control box that gives you room to work and room to mount Carrier accessory controls.

### Easy to maintain:

Easy access handles by Carrier provide quick and easy access to all major, normally serviced components. Our “no-strip” screw system has superior holding power and guides screws into position while preventing the screw from stripping the unit’s metal. Take accurate pressure readings by reading condenser pressure with panels in place as compressors are strategically located to eliminate any air bypass.

### Easy to use:

The newly designed, central terminal board by Carrier puts all your connections and troubleshooting points in one convenient place, standard. Most low voltage connections are made to the same board and make it easy to find what you’re looking for and easy to access it. Carrier rooftops have high and low pressure switches, a filter drier, and 51mm (2-in.) filters standard.

### Reliable:

Each unit comes with precision sized and tested scroll compressor that is internally protected from over temperature and pressures. In addition, each refrigerant circuit is further protected with a high pressure and low pressure switch as well as containing a liquid line filter drier. Each unit is factory tested prior to shipment to help ensure units operation once properly installed.

## Table of contents

	Page
Model number nomenclature . . . . .	3
Options and accessories . . . . .	4
Capacity ratings. . . . .	6
Physical data . . . . .	8
Dimensions . . . . .	17
Application data . . . . .	37
Performance data . . . . .	38
Fan data . . . . .	49
Electrical data . . . . .	63
Typical wiring diagrams . . . . .	65
Sequence of operation . . . . .	67
Guide specifications . . . . .	68

# Model number nomenclature



1 2 3 4 5 6 7 8 9 10 11 12 13 14 15 16 17 18  
 5 0 T C - D 2 4 A 1 G 9 - 0 A 0 A 0

Unit Heat Type  
 50 = Elect. Heat Pkg. Rooftop

Tier / Model  
 TC = WeatherMaker Series

Heat Size  
 - = None (Field-installed Accessory)

Refrig. System Options  
 D = 2-Std. Cooling

Nominal Capacity kW (Tons)  
 17 = 49.2 kW (14)  
 20 = 50.9 kW (15)      28 = 73.3 kW (20)  
 24 = 56.9 kW (17)      30 = 83.8 kW (25)

Sensor Options  
 A = None  
 B = RA Smoke Detector  
 C = SA Smoke Detector  
 D = RA + SA Smoke Detector  
 E = CO<sub>2</sub>  
 F = RA Smoke Detector & CO<sub>2</sub>  
 G = SA Smoke Detector & CO<sub>2</sub>  
 H = RA + SA Smoke Detector & CO<sub>2</sub>

Indoor Fan Options  
 1 = Standard Static / Vertical Supply, Return Air Flow  
 2 = Medium Static / Vertical Supply, Return Air Flow  
 3 = High Static / Vertical Supply, Return Air Flow  
 5 = Standard Static / Horizontal Supply, Return Air Flow  
 6 = Medium Static / Horizontal Supply, Return Air Flow  
 7 = High Static / Horizontal Supply, Return Air Flow  
 A = Std Static High Efficiency Motor / Vertical Supply, Return Air Flow  
 B = Med Static High Efficiency Motor / Vertical Supply, Return Air Flow  
 C = High Static High Efficiency Motor / Vertical Supply, Return Air Flow  
 E = Std Static High Efficiency Motor / Horiz Supply, Return Air Flow  
 F = Med Static High Efficiency Motor / Horiz Supply, Return Air Flow  
 G = High Static High Efficiency Motor / Horiz Supply, Return Air Flow

Packaging  
 0 = Standard

Electrical Options  
 A = None  
 C = Non-Fused Disconnect  
 D = Thru The Base  
 F = Non-Fused Disc Thru The Base

Future Use  
 0 = Standard

Intake / Exhaust Options  
 A = None  
 B = Temp Econo w/ Baro Relief  
 D = Temp Econo w/ PE (cent) – Vert. Air Only  
 F = Enthalpy Econo w/ Baro Relief  
 H = Enthalpy Econo w/PE (cent) – Vert. Air Only  
 K = 2 Position Damper  
 P = Manual Outdoor Air Damper

Base Unit Controls  
 0 = Electromechanical  
 1 = PremierLink Controller  
 2 = RTU Open Multi-Protocol Controller

Design Rev  
 - = Factory Assigned

Voltage  
 9 = 400/3/50

Coil Options  
 Round Tube Plate Fin Coils (Outdoor-Indoor-Hail Guard) All  
 A = Al/Cu – Al/Cu  
 B = Precoat Al/Cu – Al/Cu  
 C = E-coat Al/Cu – Al/Cu  
 D = E-coat Al/Ci – E-coat Al/Cu  
 E = Cu/Cu – Al/Cu  
 F = Cu/Cu – Cu/Cu  
 M = Al/Cu – Al/Cu – Louvered Hail Guards  
 N = Precoat Al/Cu – Al/Cu – Louvered Hail Guards  
 P = E-coat Al/Cu – Al/Cu – Louvered Hail Guards  
 Q = E-coat Al/Cu – E-coat Al/Cu – Louvered Hail Guards  
 R = Cu/Cu – Al/Cu – Louvered Hail Guards  
 S = Cu/Cu – Cu/Cu – Louvered Hail Guards

Novation Coils Only (Outdoor-Indoor-Hail Guard) 17 to 28 Sizes Only  
 G = Al/Al – Al/Cu  
 H = Al/Al – Cu/Cu  
 J = Al/Al – E-coat Al/Cu  
 K = Al/Al E-coat – Al/Cu  
 L = Al/Al E-coat – Al/Cu E-coat  
 T = Al/Al – Al/Cu, Louvered  
 U = Al/Al – Cu/Cu, Louvered  
 V = Al/Al – E-coat Al/Cu, Louvered  
 W = Al/Al E-coat – Al/Cu, Louvered  
 X = Al/al E-coat – Al/Cu E-coat, Louvered

## FACTORY-INSTALLED OPTIONS AND FIELD-INSTALLED ACCESSORIES

CATEGORY	ITEM	FACTORY-INSTALLED OPTION	FIELD-INSTALLED ACCESSORY
<b>Cabinet</b>	Dedicated Vertical Air Flow Duct Configuration	X	
	Dedicated Horizontal Air Flow Duct Configuration	X	
	Thru-the-base electrical connections	X	
<b>Coil Options</b>	Cu/Cu indoor & outdoor coils	X	
	E-coated indoor & outdoor coils	X	
	Pre-coated outdoor coils	X	
<b>Condenser Protection</b>	Condenser coil hail guard (louvered design)	X	X
	Thermostats, temperature sensors, and subbases		X
<b>Controls</b>	PremierLink DDC communicating controller <sup>1</sup>	X	X
	RTU Open Multi-Protocol controller <sup>2</sup>	X	
	Smoke detector (supply and/or return air)	X	X
	Time Guard II compressor delay control circuit		X
	Phase Monitor		X
<b>Economizers &amp; Outdoor Air Dampers</b>	EconoMi\$er IV (for electro-mechanical controlled RTUs)	X	X
	EconoMi\$er2 (for DDC controlled RTUs)	X	X
	Motorized 2 position outdoor-air damper	X	X
	Manual outdoor-air damper (25%)		X
	Barometric relief <sup>3</sup>	X	X
	Power exhaust	X	X
<b>Economizer Sensors &amp; IAQ Devices</b>	Single dry bulb temperature sensors <sup>4</sup>	X	X
	Differential dry bulb temperature sensors <sup>4</sup>		X
	Single enthalpy sensors <sup>4</sup>	X	X
	Differential enthalpy sensors <sup>4</sup>		X
	CO <sub>2</sub> sensor (wall, duct, or unit mounted) <sup>5</sup>	X	X
<b>Electric Heat</b>	Electric Resistance Heaters		X
	Single Point Kit		X
	Indoor Motor & Drive Multiple motor and drive packages	X	
<b>Low Ambient Control</b>	Winter start kit <sup>3</sup>		X
	Motormaster head pressure controller <sup>6</sup>		X
	Power Options Non-fused disconnect	X	
<b>Roof Curbs</b>	Roof curb 356mm (14-in.)		X
	Roof curb 610mm (24-in.)		X
	Adapter Curb (Adapts to Models – DP/DR/HJ/TM)		X

**NOTES:**

1. PremierLink available in English language only, supports metric or Imperial units of measure
2. RTU Open available in English language only. Only supports Imperial units of measure.

3. Included with economizer.
4. Sensors for optimizing economizer.
5. See application data for assistance.

## Factory-installed options and field-installed accessories

### Economizer (dry-bulb or enthalpy)

Economizers save money. They bring in fresh, outside air for ventilation; and provide cool, outside air to cool your building. This is the preferred method of low-ambient cooling. When coupled to CO<sub>2</sub> sensors, Economizers can provide even more savings by coupling the ventilation air to only that amount required.

Economizers are available, installed and tested by the factory, with either enthalpy or dry-bulb temperature inputs. There are also models for electromechanical as well as direct digital controllers. Additional sensors are available as accessories to optimize the economizers.

Economizers include gravity controlled, barometric relief equalizes building pressure and ambient air pressures. This can be a cast effective solution to prevent building pressurization. If further control of exhaust air is required, a dual centrifugal fan power exhaust system is also available.

### CO<sub>2</sub> Sensor

Improves productivity and saves money by working with the economizer to intake only the correct amount of outside air for ventilation. As occupants fill your building, the CO<sub>2</sub> sensor detects their presence through increasing CO<sub>2</sub> levels, and opens the economizer appropriately.

When the occupants leave, the CO<sub>2</sub> levels decrease, and the sensor appropriately closes the economizer. This intelligent control of the ventilation air, called Demand Control Ventilation (DCV) reduces the overall load on the rooftop, saving money.

### Smoke Detectors

Trust the experts. Smoke detectors make your application safer and your job easier. Carrier smoke detectors immediately shut down the rooftop unit when smoke is detected. They are available, installed by the factory, for supply air, return air, or both.

### Louvered Hail Guards

Sleek, louvered panels protect the condenser coil from hail damage, foreign objects, and incidental contact.

### Non-Fused Disconnect

This OSHA-compliant, factory-installed, safety switch allows a service technician to locally secure power to the rooftop.

### Power Exhaust with Barometric Relief

Superior internal building pressure control. This field-installed accessory or factory-installed option may eliminate the need for costly, external pressure control fans.

### PremierLink, DDC Controller

This CCN controller regulates your rooftop's performance to tighter tolerances and expanded limits, as well as facilitates zoning systems and digital accessories. It also unites your Carrier HVAC equipment together on one, coherent CCN network. The PremierLink can be factory-installed, or easily field-installed. Available in English language only. Supports Metric or Imperial units of measure.

### RTU Open Multi-Protocol Controller

Connect the rooftop to an existing BAS without needing complicated translators or adapter modules using the RTU Open controller. This new controller speaks the 4 most common building automation system languages (BACnet<sup>1</sup>, Modbus<sup>2</sup>, N2, and Lonworks<sup>3</sup>). Use this controller when you have an existing BAS.

Available in English language only. Supports Imperial units of measure only.

### Time Guard II Control Circuit

This accessory protects your compressor by preventing short-cycling in the event of some other failure, prevents the compressor from restarting for 30 seconds after stopping. Not required with PremierLink, RTU Open, or authorized commercial thermostats.

### Filter or Fan Status Switches

Use these differential pressure switches to detect a filter clog or indoor fan motor failure. When used in conjunction with a compatible unit controller/thermostat, the switches will activate an alarm to warn the appropriate personnel.

### Motorized 2-Position Damper

The new Carrier 2-position, motorized outdoor air damper admits up to 100% outside air. Using reliable, gear-driven technology, the 2-position damper opens to allow ventilation air and closes when the rooftop stops, stopping unwanted infiltration.

### Manual OA Damper

Manual outdoor air dampers are an economical way to bring in ventilation air. The dampers are available in 25% versions.

### Motormaster Head Pressure Controller

The Motormaster motor controller is a low ambient, head pressure controller kit that is designed to maintain the unit's condenser head pressure during periods of low ambient cooling operation. This device should be used as an alternative to economizer free cooling not when economizer usage is either not appropriate or desired. The Motormaster will either cycle the outdoor-fan motors or operate them at reduced speed to maintain the unit operation, depending on the model.

### Winter Start Kit

The winter start kit by Carrier extends the low ambient limit of your rooftop to -4°C (25°F). The kit bypasses the low pressure switch, preventing nuisance tripping of the low pressure switch. Other low ambient precautions may still be prudent.

### Alternate Motors and Drives

Some applications need larger horsepower motors, some need more airflow, and some need both. Regardless of the case, your Carrier expert has a factory installed combination to meet your application. A wide selection of motors and pulleys (drives) are available, factory installed, to handle nearly any application.

### Thru-the-Base Connections

Thru-the-base connections, available as a factory option, are necessary to ensure proper connection and seal when routing wire and piping through the rooftop's basepan and curb. These couplings eliminate roof penetration and should be considered for main power lines, as well as control power.

### Electric Heaters / Single Point Kit

Carrier offers a full-line of field-installed accessory heaters and single point kits when required. The heaters are very easy to use, install and are all pre-engineered and certified.

1. BACnet is a registered trademark of ASHRAE (American Society of Heating, Refrigerating and Air-Conditioning Engineers).
2. Modbus is a registered trademark of Schneider Electric.
3. LonWorks is a registered trademark of Echelon Corporation.

## COOLING RATING TABLE 2-STAGE COOLING

UNIT 50TC	NET CAPACITY		EER	IPLV	NOMINAL AIRFLOW	
	kW	Btuh			L/s	CFM
17	47.8	168,000	11.64	12.5	2500	5400
20	51.5	174,000	11.43	12.5	2900	6114
24	58.8	194,000	11.1	13.0	3200	6806
28	68.8	250,000	11.2	12.2	3800	8033
30	83.8	286,000	11.3	12.0	3800	8033

**LEGEND**

- ASHRAE** — American Society of Heating, Refrigerating and Air Conditioning  
**EER** — Energy Efficiency Ratio  
**IPLV** — Integrated Part Load Value

**NOTES:**

- Ratings are based on:  
 Cooling Standard: 27°C (80°F) db, 19°C (67°F) wb indoor air temp and 35°C (95°F) db outdoor air temp.  
 IPLV Standard: 27°C (80°F) db, 19°C (67°F) wb indoor air temp and 27°C (80°F) db outdoor air temp.
- All 50TC units comply with ASHRAE 90.1 Energy Standard for minimum EER and IPLV requirements.



### MINIMUM AIRFLOWS ELECTRIC HEAT

UNIT 50TC	NOMINAL kW	MINIMUM AIRFLOW	
		L/s	CFM
17	25	2124	4500
	50		
	75		
20	25	2454	5200
	50		
	75		
24	25	2832	6000
	50		
	75		
28	25	3303	7000
	50		
	75		
30	25	4011	8500
	50		
	75		

**SOUND PERFORMANCE TABLE**

50TC MODEL SIZE	OUTDOOR SOUND (dB)									
	A-Wtg.	AHRI 370 RATING	63	125	250	500	1000	2000	4000	8000
17	84.1	84	92.2	83.9	80.4	81.8	78.7	76.5	72.2	65.4
20	84.1	84	92.2	83.9	80.4	81.8	78.7	76.5	72.2	65.4
24	86.5	87	95.6	87.5	84.2	84.2	81.7	77.9	73.2	66.3
28	85.9	86	97.1	88.3	84.4	83.3	80.7	77.4	73.4	67.3
30	85.9	86	97.1	88.3	84.4	83.3	80.7	77.4	73.4	67.3

**LEGEND**

**dB** — Decibel

**NOTES:**

1. Outdoor sound data is measure in accordance with AHRI standard 270.
2. Measurements are expressed in terms of sound power. Do not compare these values to sound pressure values because sound pressure accounts for specific environmental factors which do not match individual applications. Sound power values are independent of the environment and therefore more accurate.

3. A-weighted sound ratings filter out very high and very low frequencies, to better approximate the response of an “average” human ear. A-weighted measurements for Carrier units are taken in accordance with 270.

## COOLING — RTPF (SI)

	50TC17	50TC20	50TC24	50TC28	50TC30
<b>Refrigeration System</b>	RTPF	RTPF	RTPF	RTPF	RTPF
# Circuits / # Comp. / Type	2 / 2 / Scroll	2 / 2 / Scroll	2 / 2 / Scroll	2 / 2 / Scroll	2 / 2 / Scroll
R-410A charge A/B (kg)	7.3 / 7.7	7.3 / 7.7	8.9 / 6.3	8.4 / 8.9	12.1 / 12.0
Metering device	Acutrol	Acutrol	Acutrol	Acutrol	Acutrol
High-press. Trip / Reset (kPa)	4344 / 3482	4344 / 3482	4344 / 3482	4344 / 3482	4344 / 3482
Low-press. Trip / Reset (kPa)	372 / 807	372 / 807	372 / 807	372 / 807	372 / 807
<b>Evaporator Coil</b>					
Material - Tube / Fin	Cu / Al	Cu / Al	Cu / Al	Cu / Al	Cu / Al
Tube Diameter (mm)	10	10	10	10	10
Rows / Fins perimeter	4 / 591	4 / 591	4 / 591	4 / 591	4 / 591
Total face area (m <sup>2</sup> )	2.04	2.04	2.04	2.15	2.41
Condensate drain connection (mm)	19	19	19	19	19
<b>Evaporator fan and motor</b>					
<b>VERTICAL</b>					
<b>Standard Static</b>					
Motor Qty / Drive type	1 / Belt	1 / Belt	1 / Belt	1 / Belt	1 / Belt
Max BHP	2.2	3.3	6.5	6.5	6.5
r/s range	8-10	8-11	9-13	11-13	10-13
Motor frame size	56	56	184T	184T	184T
Fan Qty / Type	2 / Centrifugal	2 / Centrifugal	2 / Centrifugal	2 / Centrifugal	2 / Centrifugal
Fan Diameter (mm)	381 x 381	381 x 381	381 x 381	381 x 381	381 x 381
<b>Medium Static</b>					
Motor Qty / Drive type	1 / Belt	1 / Belt	1 / Belt	1 / Belt	1 / Belt
Max BHP	3.3	6.5	6.5	6.5	10.9
r/s range	9-12	11-13	11-14	13-15	12-15
Motor frame size	56	184T	184T	184T	213T
Fan Qty / Type	2 / Centrifugal	2 / Centrifugal	2 / Centrifugal	2 / Centrifugal	2 / Centrifugal
Fan Diameter (mm)	381 x 381	381 x 381	381 x 381	381 x 381	381 x 381
<b>High Static</b>					
Motor Qty / Drive type	1 / Belt	1 / Belt	1 / Belt	1 / Belt	1 / Belt
Max BHP	6.5	6.5	10.9	10.9	11.9
r/s range	12-15	13-17	14-17	15-18	15-19
Motor frame size	184T	184T	213T	213T	215T
Fan Qty / Type	2 / Centrifugal	2 / Centrifugal	2 / Centrifugal	2 / Centrifugal	2 / Centrifugal
Fan Diameter (mm)	381 x 381	381 x 381	381 x 381	381 x 381	381 x 381
<b>HORIZONTAL</b>					
<b>Standard Static</b>					
Motor Qty / Drive type	1 / Belt	1 / Belt	1 / Belt	1 / Belt	1 / Belt
Max BHP	2.2	3.3	6.5	6.5	6.5
r/s range	8-10	8-11	9-13	11-13	11-14
Motor frame size	56	56	184T	184T	184T
Fan Qty / Type	2 / Centrifugal	2 / Centrifugal	2 / Centrifugal	2 / Centrifugal	2 / Centrifugal
Fan Diameter (mm)	457x381/381x279	457x381/381x279	457x381/381x279	457x381/381x279	457x381/381x279
<b>Medium Static</b>					
Motor Qty / Drive type	1 / Belt	1 / Belt	1 / Belt	1 / Belt	1 / Belt
Max BHP	3.3	6.5	6.5	6.5	10.9
r/s range	9-12	11-13	11-14	13-15	15-19
Motor frame size	56	184T	184T	184T	213T
Fan Qty / Type	2 / Centrifugal	2 / Centrifugal	2 / Centrifugal	2 / Centrifugal	2 / Centrifugal
Fan Diameter (mm)	457x381/381x279	457x381/381x279	457x381/381x279	457x381/381x279	457x381/381x279
<b>High Static</b>					
Motor Qty / Drive type	1 / Belt	1 / Belt	1 / Belt	2 / Belt	2 / Belt
Max BHP	6.5	6.5	10.9	10.9	11.9
r/s range	12-15	13-17	14-17	15-18	15-19
Motor frame size	184T	184T	213T	213T	215T
Fan Qty / Type	2 / Centrifugal	2 / Centrifugal	2 / Centrifugal	2 / Centrifugal	2 / Centrifugal
Fan Diameter (mm)	457x381/381x279	457x381/381x279	457x381/381x279	457x381/381x279	457x381/381x279



# Physical data (cont)



## COOLING — RTPF (SI) (cont)

	50TC17	50TC20	50TC24	50TC28	50TC30
<b>Condenser Coil (Circuit A)</b>					
Coil type	RTPF	RTPF	RTPF	RTPF	RTPF
Coil Length (mm)	1778	1778	2083	1905	2413
Coil Height (mm)	1118	1118	1118	1321	1321
Number of Passes   Rows / FPI	2 / 669	2 / 669	2 / 669	2 / 669	2 / 669
Total face area (m <sup>2</sup> )	2.0	2.0	1.6	2.5	3.2
<b>Condenser Coil (Circuit B)</b>					
Coil type	RTPF	RTPF	RTPF	RTPF	RTPF
Coil Length (mm)	1778	1778	1448	1905	2413
Coil Height (mm)	1118	1118	1118	1321	1321
Rows / Fins perimeter	2 / 669	2 / 669	2 / 669	2 / 669	2 / 669
Total face area (m <sup>2</sup> )	2.0	2.0	1.6	2.5	3.2
<b>Condenser fan / motor</b>					
Qty / Motor drive type	3 / direct	3 / direct	4 / direct	4 / direct	6 / direct
Motor kW / r/s	.186 / 18	.186 / 18	.186 / 18	.186 / 18	.186 / 18
Fan diameter (mm)	559	559	559	559	559
<b>Filters</b>					
RA Filter # / size (mm)	6 / 508x635x51	6 / 508x635x51	6 / 508x635x51	9 / 406x635x51	9 / 406x635x51
OA inlet screen # / size (mm)	4 / 406x635x25	4 / 406x635x25	4 / 406x635x25	4 / 406x635x25	4 / 406x635x25

## COOLING — NOVATION (SI)

	50TC17	50TC20	50TC24	50TC28
<b>Refrigeration System</b>	Novation	Novation	Novation	Novation
# Circuits / # Comp. / Type	2 / 2 / Scroll	2 / 2 / Scroll	2 / 2 / Scroll	2 / 2 / Scroll
R-410A charge A/B (kg)	4 / 5	4 / 5	5.3 / 4.1	5.5 / 5.6
Metering device	Acutrol	Acutrol	Acutrol	Acutrol
High-press. Trip / Reset (kPa)	4344 / 3482	4344 / 3482	4344 / 3482	4344 / 3482
Low-press. Trip / Reset (kPa)	372 / 807	372 / 807	372 / 807	372 / 807
<b>Evaporator Coil</b>				
Material - Tube / Fin	Cu / Al	Cu / Al	Cu / Al	Cu / Al
Tube Diameter (mm)	10	10	10	10
Rows / Fins perimeter	4 / 591	4 / 591	4 / 591	4 / 591
Total face area (m <sup>2</sup> )	1.8	1.8	2.04	2.15
Condensate drain connection (mm)	19	19	19	19
<b>Evaporator fan and motor</b>				
<b>VERTICAL</b>				
<b>Standard Static</b>				
Motor Qty / Drive type	1 / Belt	1 / Belt	1 / Belt	1 / Belt
Max BHP	2.2	3.3	6.5	6.5
r/s range	8-10	8-11	9-13	11-13
Motor frame size	56	56	184T	184T
Fan Qty / Type	2 / Centrifugal	2 / Centrifugal	2 / Centrifugal	2 / Centrifugal
Fan Diameter (mm)	381 x 381	381 x 381	381 x 381	381 x 381
<b>Medium Static</b>				
Motor Qty / Drive type	1 / Belt	1 / Belt	1 / Belt	1 / Belt
Max BHP	3.3	6.5	6.5	6.5
r/s range	9-12	11-13	11-14	13-15
Motor frame size	56	184T	184T	184T
Fan Qty / Type	2 / Centrifugal	2 / Centrifugal	2 / Centrifugal	2 / Centrifugal
Fan Diameter (mm)	381 x 381	381 x 381	381 x 381	381 x 381
<b>High Static</b>				
Motor Qty / Drive type	1 / Belt	1 / Belt	1 / Belt	1 / Belt
Max BHP	6.5	6.5	10.9	10.9
r/s range	12-15	13-17	14-17	15-18
Motor frame size	184T	184T	213T	213T
Fan Qty / Type	2 / Centrifugal	2 / Centrifugal	2 / Centrifugal	2 / Centrifugal
Fan Diameter (mm)	381 x 381	381 x 381	381 x 381	381 x 381
<b>HORIZONTAL</b>				
<b>Standard Static</b>				
Motor Qty / Drive type	1 / Belt	1 / Belt	1 / Belt	1 / Belt
Max BHP	2.2	3.3	6.5	6.5
r/s range	8-10	8-11	9-13	11-13
Motor frame size	56	56	184T	184T
Fan Qty / Type	2 / Centrifugal	2 / Centrifugal	2 / Centrifugal	2 / Centrifugal
Fan Diameter (mm)	457x381/381x279	457x381/381x279	457x381/381x279	457x381/381x279
<b>Medium Static</b>				
Motor Qty / Drive type	1 / Belt	1 / Belt	1 / Belt	1 / Belt
Max BHP	3.3	6.5	6.5	6.5
r/s range	9-12	11-13	11-14	13-15
Motor frame size	56	184T	184T	184T
Fan Qty / Type	2 / Centrifugal	2 / Centrifugal	2 / Centrifugal	2 / Centrifugal
Fan Diameter (mm)	457x381/381x279	457x381/381x279	457x381/381x279	457x381/381x279
<b>High Static</b>				
Motor Qty / Drive type	1 / Belt	1 / Belt	1 / Belt	2 / Belt
Max BHP	6.5	6.5	10.9	10.9
r/s range	12-15	13-17	14-17	15-18
Motor frame size	184T	184T	213T	213T
Fan Qty / Type	2 / Centrifugal	2 / Centrifugal	2 / Centrifugal	2 / Centrifugal
Fan Diameter (mm)	457x381/381x279	457x381/381x279	457x381/381x279	457x381/381x279

# Physical data (cont)



## COOLING — NOVATION (SI) (cont)

	50TC17	50TC20	50TC24	50TC28
<b>Condenser Coil (Circuit A)</b>				
Coil type	Novation	Novation	Novation	Novation
Coil Length (mm)	1778	1778	2083	1905
Coil Height (mm)	1118	1118	1118	1321
Number of Passes   Rows / FPI	2 / 669	2 / 669	2 / 669	2 / 669
Total face area (m <sup>2</sup> )	2.0	2.0	1.6	2.5
<b>Condenser Coil (Circuit B)</b>				
Coil type	Novation	Novation	Novation	Novation
Coil Length (mm)	1778	1778	1448	1905
Coil Height (mm)	1118	1118	1118	1321
Rows / Fins perimeter	2 / 669	2 / 669	2 / 669	2 / 669
Total face area (m <sup>2</sup> )	2.0	2.0	1.6	2.5
<b>Condenser fan / motor</b>				
Qty / Motor drive type	3 / direct	3 / direct	4 / direct	4 / direct
Motor kW / r/s	.186 / 18	.186 / 18	.186 / 18	.186 / 18
Fan diameter (mm)	559	559	559	559
<b>Filters</b>				
RA Filter # / size (mm)	6 / 508x635x51	6 / 508x635x51	6 / 508x635x51	9 / 406x635x51
OA inlet screen # / size (mm)	4 / 406x635x25	4 / 406x635x25	4 / 406x635x25	4 / 406x635x25

## COOLING — RTPF (English)

	50TC17	50TC20	50TC24	50TC28	50TC30
<b>Refrigeration System</b>	RTPF	RTPF	RTPF	RTPF	RTPF
# Circuits / # Comp. / Type	2 / 2 / Scroll	2 / 2 / Scroll	2 / 2 / Scroll	2 / 2 / Scroll	2 / 2 / Scroll
R-410A charge A/B (lbs)	16.0/17.0	16.0/17.0	19.3/13.9	18.5 / 19.6	26.6/ 26.5
Metering device	Acutrol	Acutrol	Acutrol	Acutrol	Acutrol
High-press. Trip / Reset (psig)	630 / 505	630 / 505	630 / 505	630 / 505	630 / 505
Low-press. Trip / Reset (psig)	54 / 117	54 / 117	54 / 117	54 / 117	54 / 117
<b>Evaporator Coil</b>					
Material - Tube / Fin	Cu / Al	Cu / Al	Cu / Al	Cu / Al	Cu / Al
Tube Diameter (in.)	3/8- in.	3/8- in.	3/8- in.	3/8- in	3/8- in.
Rows / Fins per inch	4 / 15	4 / 15	4 / 15	4 / 15	4 / 15
Total face area (ft <sup>2</sup> )	22.00	22.00	22.00	23.11	26.00
Condensate drain connection (in.)	3/4- in.	3/4- in.	3/4- in.	3/4- in.	3/4- in.
<b>Evaporator fan and motor</b>					
<b>VERTICAL</b>					
<b>Standard Static</b>					
Motor Qty / Drive type	1 / Belt	1 / Belt	1 / Belt	1 / Belt	1 / Belt
Max BHP	2.2	3.3	6.5	6.5	6.5
RPM range	463-588	507-644	566-692	656-809	617-784
Motor frame size	56	56	184T	184T	184T
Fan Qty / Type	2 / Centrifugal	2 / Centrifugal	2 / Centrifugal	2 / Centrifugal	2 / Centrifugal
Fan Diameter (in.)	15 x 15	15 x 15	15 x 15	15 x 15	15 x 15
<b>Medium Static</b>					
Motor Qty / Drive type	1 / Belt	1 / Belt	1 / Belt	1 / Belt	1 / Belt
Max BHP	3.3	6.5	6.5	6.5	10.9
RPM range	561-713	652-803	687-840	751-918	733-916
Motor frame size	56	184T	184T	184T	213T
Fan Qty / Type	2 / Centrifugal	2 / Centrifugal	2 / Centrifugal	2 / Centrifugal	2 / Centrifugal
Fan Diameter (in.)	15 x 15	15 x 15	15 x 15	15 x 15	15 x 15
<b>High Static</b>					
Motor Qty / Drive type	1 / Belt	1 / Belt	1 / Belt	1 / Belt	1 / Belt
Max BHP	6.5	6.5	10.9	10.9	11.9
RPM range	726-887	801-1001	824-1008	871-1064	918-1151
Motor frame size	184T	184T	213T	213T	215T
Fan Qty / Type	2 / Centrifugal	2 / Centrifugal	2 / Centrifugal	2 / Centrifugal	2 / Centrifugal
Fan Diameter (in.)	15 x 15	15 x 15	15 x 15	15 x 15	15 x 15
<b>HORIZONTAL</b>					
<b>Standard Static</b>					
Motor Qty / Drive type	1 / Belt	1 / Belt	1 / Belt	1 / Belt	1 / Belt
Max BHP	2.2	3.3	6.5	6.5	6.5
RPM range	463-588	507-644	566-692	656-809	687-840
Motor frame size	56	56	184T	184T	184T
Fan Qty / Type	2 / Centrifugal	2 / Centrifugal	2 / Centrifugal	2 / Centrifugal	2 / Centrifugal
Fan Diameter (in.)	18 x 15 / 15 x 11	18 x 15 / 15 x 11	18 x 15 / 15 x 11	18 x 15 / 15 X 11	18 x 15 / 15 x 11
<b>Medium Static</b>					
Motor Qty / Drive type	1 / Belt	1 / Belt	1 / Belt	1 / Belt	1 / Belt
Max BHP	3.3	6.5	6.5	6.5	10.9
RPM range	561-713	652-803	687-840	751-918	824-1008
Motor frame size	56	184T	184T	184T	213T
Fan Qty / Type	2 / Centrifugal	2 / Centrifugal	2 / Centrifugal	2 / Centrifugal	2 / Centrifugal
Fan Diameter (in.)	18 x 15 / 15 x 11	18 x 15 / 15 x 11	18 x 15 / 15 x 11	18 x 15 / 15 x 11	18 x 15 / 15 x 11
<b>High Static</b>					
Motor Qty / Drive type	1 / Belt	1 / Belt	1 / Belt	2 / Belt	2 / Belt
Max BHP	6.5	6.5	10.9	10.9	11.9
RPM range	726-887	801-1001	824-1008	871-1064	918-1151
Motor frame size	184T	184T	213T	213T	215T
Fan Qty / Type	2 / Centrifugal	2 / Centrifugal	2 / Centrifugal	2 / Centrifugal	2 / Centrifugal
Fan Diameter (in.)	18 x 15 / 15 x 11	18 x 15 / 15 x 11	18 x 15 / 15 x 11	18 x 15 / 15 x 11	18 x 15 / 15 x 11

# Physical data (cont)



## COOLING — RTPF (English) (cont)

	50TC17	50TC20	50TC24	50TC28	50TC30
<b>Condenser Coil (Circuit A)</b>					
Coil type	RTPF	RTPF	RTPF	RTPF	RTPF
Coil Length (in.)	70	70	82	75	95
Coil Height (in.)	44	44	44	52	52
Number of Passes   Rows / FPI	2 / 17	2 / 17	2 / 17	2 / 17	2 / 17
Total face area (ft <sup>2</sup> )	21.4	21.4	25.1	27.1	34.3
<b>Condenser Coil (Circuit B)</b>					
Coil type	RTPF	RTPF	RTPF	RTPF	RTPF
Coil Length (in.)	70	70	57	75	95
Coil Height (in.)	44	44	44	52	52
Rows / Fins per inch	2 / 17	2 / 17	2 / 17	2 / 17	2 / 17
Total face area (ft <sup>2</sup> )	21.4	21.4	17.4	27.1	34.3
<b>Condenser fan / motor</b>					
Qty / Motor drive type	3 / direct	3 / direct	4 / direct	4 / direct	6 / direct
Motor HP / RPM	1/4 / 1100	1/4 / 1100	1/4 / 1100	1/4 / 1100	1/4 / 1100
Fan diameter (in.)	22	22	22	22	22
<b>Filters</b>					
RA Filter # / size (in.)	6 / 20 x 25 x 2	6 / 20 x 25 x 2	6 / 20 x 25 x 2	9 / 16 x 25 x 2	9 / 16 x 25 x 2
OA inlet screen # / size (in.)	4 / 16 x 25 x 1	4 / 16 x 25 x 1	4 / 16 x 25 x 1	4 / 16 x 25 x 1	4 / 16 x 25 x 1

## COOLING — NOVATION (English)

	50TC17	50TC20	50TC24	50TC28
<b>Refrigeration System</b>	Novation	Novation	Novation	Novation
# Circuits / # Comp. / Type	2 / 2 / Scroll	2 / 2 / Scroll	2 / 2 / Scroll	2 / 2 / Scroll
R-410a charge A/B (lbs)	8.6/11.2	8.6/11.2	11.7/9.1	12.1/12.4
Metering device	Acutrol	Acutrol	Acutrol	Acutrol
High-press. Trip / Reset (psig)	630 / 505	630 / 505	630 / 505	630 / 505
Low-press. Trip / Reset (psig)	54 / 117	54 / 117	54 / 117	54 / 117
<b>Evaporator Coil</b>				
Material - Tube / Fin	Cu / Al	Cu / Al	Cu / Al	Cu / Al
Tube Diameter (in.)	3/8- in.	3/8- in.	3/8- in.	3/8- in.
Rows / Fins per inch	4 / 15	4 / 15	4 / 15	4 / 15
Total face area (ft <sup>2</sup> )	19.56	19.56	22.00	23.11
Condensate drain conn. (in.)	3/4- in.	3/4- in.	3/4- in.	3/4- in.
<b>Evaporator fan and motor</b>				
<b>VERTICAL</b>				
<b>Standard Static</b>				
Motor Qty / Drive type	1 / Belt	1 / Belt	1 / Belt	1 / Belt
Max BHP	2.2	3.3	6.5	6.5
RPM range	463-588	507-644	566-692	656-809
Motor frame size	56	56	184T	184T
Fan Qty / Type	2 / Centrifugal	2 / Centrifugal	2 / Centrifugal	2 / Centrifugal
Fan Diameter (in.)	15 x 15	15 x 15	15 x 15	15 x 15
<b>Medium Static</b>				
Motor Qty / Drive type	1 / Belt	1 / Belt	1 / Belt	1 / Belt
Max BHP	3.3	6.5	6.5	6.5
RPM range	561-713	652-803	687-840	751-918
Motor frame size	56	184T	184T	184T
Fan Qty / Type	2 / Centrifugal	2 / Centrifugal	2 / Centrifugal	2 / Centrifugal
Fan Diameter (in.)	15 x 15	15 x 15	15 x 15	15 x 15
<b>High Static</b>				
Motor Qty / Drive type	1 / Belt	1 / Belt	1 / Belt	1 / Belt
Max BHP	6.5	6.5	10.9	10.9
RPM range	726-887	801-1001	824-1008	871-1064
Motor frame size	184T	184T	213T	213T
Fan Qty / Type	2 / Centrifugal	2 / Centrifugal	2 / Centrifugal	2 / Centrifugal
Fan Diameter (in.)	15 x 15	15 x 15	15 x 15	15 x 15
<b>HORIZONTAL</b>				
<b>Standard Static</b>				
Motor Qty / Drive type	1 / Belt	1 / Belt	1 / Belt	1 / Belt
Max BHP	2.2	3.3	6.5	6.5
RPM range	463-588	507-644	566-692	656-809
Motor frame size	56	56	184T	184T
Fan Qty / Type	2 / Centrifugal	2 / Centrifugal	2 / Centrifugal	2 / Centrifugal
Fan Diameter (in.)	18 x 15 / 15 x 11	18 x 15 / 15 x 11	15 x 15 18 x 15 / 15 x 11	
<b>Medium Static</b>				
Motor Qty / Drive type	1 / Belt	1 / Belt	1 / Belt	1 / Belt
Max BHP	3.3	6.5	6.5	6.5
RPM range	561-713	652-803	687-840	751-918
Motor frame size	56	184T	184T	184T
Fan Qty / Type	2 / Centrifugal	2 / Centrifugal	2 / Centrifugal	2 / Centrifugal
Fan Diameter (in.)	18 x 15 / 15 x 11	18 x 15 / 15 x 11	15 x 15	18 x 15 / 15 x 11
<b>High Static</b>				
Motor Qty / Drive type	1 / Belt	1 / Belt	1 / Belt	2 / Belt
Max BHP	6.5	6.5	10.9	10.9
RPM range	726-887	801-1001	824-1008	871-1064
Motor frame size	184T	184T	213T	213T
Fan Qty / Type	2 / Centrifugal	2 / Centrifugal	2 / Centrifugal	2 / Centrifugal
Fan Diameter (in.)	18 x 15 / 15 x 11	18 x 15 / 15 x 11	15 x 15	18 x 15 / 15 x 11

# Physical data (cont)



## COOLING — NOVATION (English) (cont)

	50TC17	50TC20	50TC24	50TC28
<b>Condenser Coil (Circuit A)</b>				
Coil type	Novation	Novation	Novation	Novation
Coil Length (in.)	70	70	82	75
Coil Height (in.)	44	44	44	52
Number of Passes   Rows / FPI	2 / 17	2 / 17	2 / 17	2 / 17
Total face area (ft <sup>2</sup> )	21.4	21.4	25.1	27.1
<b>Condenser Coil (Circuit B)</b>				
Coil type	Novation	Novation	Novation	Novation
Coil Length (in.)	70	70	57	75
Coil Height (in.)	44	44	44	52
Rows / Fins per inch	2 / 17	2 / 17	2 / 17	2 / 17
Total face area (ft <sup>2</sup> )	21.4	21.4	17.4	27.1
<b>Condenser fan / motor</b>				
Qty / Motor drive type	3 / direct	3 / direct	4 / direct	4 / direct
Motor HP / RPM	1/4 / 1100	1/4 / 1100	1/4 / 1100	1/4 / 1100
Fan diameter (in.)	22	22	22	22
<b>Filters</b>				
RA Filter # / size (in.)	6 / 20 x 25 x 2	6 / 20 x 25 x 2	6 / 20 x 25 x 2	9 / 16 x 25 x 2
OA inlet screen # / size (in.)	4 / 16 x 25 x 1	4 / 16 x 25 x 1	4 / 16 x 25 x 1	4 / 16 x 25 x 1

## ELECTRIC HEAT — ELECTRICAL DATA

50TC	NOM. V-Ph-Hz	INDOOR AIRFLOW	ELECTRIC HEATER PART NUMBER	NOMINAL (kW)	APPLICATION (kW)	APPLICATION OUTPUT (MBH)
17	400-3-50	VERTICAL	CRHEATER282A00	17.4	17.4	59.4
			CRHEATER283A00	34.7	34.7	11.84
			CRHEATER284A00	52.1	52.1	177.8
		HORIZONTAL	CRHEATER273A00	17.4	17.4	59.4
			CRHEATER274A00	34.7	34.7	11.84
			CRHEATER275A00	52.1	52.1	177.8
20	400-3-50	VERTICAL	CRHEATER282A00	17.4	17.4	59.4
			CRHEATER283A00	34.7	34.7	11.84
			CRHEATER284A00	52.1	52.1	177.8
		HORIZONTAL	CRHEATER273A00	17.4	17.4	59.4
			CRHEATER274A00	34.7	34.7	11.84
			CRHEATER275A00	52.1	52.1	177.8
24	400-3-50	VERTICAL	CRHEATER282A00	17.4	17.4	59.4
			CRHEATER283A00	34.7	34.7	11.84
			CRHEATER284A00	52.1	52.1	177.8
		HORIZONTAL	CRHEATER273A00	17.4	17.4	59.4
			CRHEATER274A00	34.7	34.7	11.84
			CRHEATER275A00	52.1	52.1	177.8
28	400-3-50	VERTICAL	CRHEATER282A00	17.4	17.4	59.4
			CRHEATER283A00	34.7	34.7	11.84
			CRHEATER284A00	52.1	52.1	177.8
		HORIZONTAL	CRHEATER273A00	17.4	17.4	59.4
			CRHEATER274A00	34.7	34.7	11.84
			CRHEATER275A00	52.1	52.1	177.8
30	400-3-50	VERTICAL	CRHEATER282A00	17.4	17.4	59.4
			CRHEATER283A00	34.7	34.7	11.84
			CRHEATER284A00	52.1	52.1	177.8
		HORIZONTAL	CRHEATER273A00	17.4	17.4	59.4
			CRHEATER274A00	34.7	34.7	11.84
			CRHEATER275A00	52.1	52.1	177.8



## DIMENSIONS 50TC-D17 AND 20

THIS DOCUMENT IS THE PROPERTY OF UTC CLIMATE CONTROL. DISSEMINATION OF THESE DRAWINGS OR REVISIONS TO THESE DRAWINGS IS PROHIBITED WITHOUT THE EXPRESS WRITTEN PERMISSION OF UTC CLIMATE CONTROL. THESE DRAWINGS DO NOT CONSTITUTE PART PERFORMANCE OR WARRANTY OF ANY KIND. ALL DIMENSIONS ARE TO FACE UNLESS OTHERWISE SPECIFIED. DIMENSIONS MAY VARY WITHOUT WRITTEN CONSENT.

CONNECTION SIZES	
A	1 3/8" DIA [135] FIELD POWER SUPPLY KNOCKOUT
B	3" DIA [76] FIELD POWER SUPPLY KNOCKOUT
C	3 5/8" DIA [92] FIELD POWER SUPPLY KNOCKOUT
D	7/8" DIA [22] FIELD CONTROL WIRING HOLE
G	7/8" DIA [22] FIELD CONTROL WIRING KNOCKOUT

**NOTES:**

- DIMENSIONS ARE IN INCHES. DIMENSIONS IN [ ] ARE IN MILLIMETERS.
- CENTER OF GRAVITY
- DIRECTION OF AIR FLOW
- ALL VIEW DRAWN USING 3RD ANGLE

**TOP**

**FRONT**

**BACK**

**LEFT**

**LEFT**

**RIGHT**

TIC CLASSIFICATION  
U.S. ECCN: NSR

SHEET  
1 OF 5

DATE  
01/16/19

SUPERCEDES  
10/19/13

50TC 17-20 50HZ SINGLE ZONE ELECTRICAL COOLING WITH ELECTRIC HEAT

REV  
B

**DEDICATED VERTICAL AIRFLOW UNIT**

## DIMENSIONS 50TC-D17 AND 20 (cont)

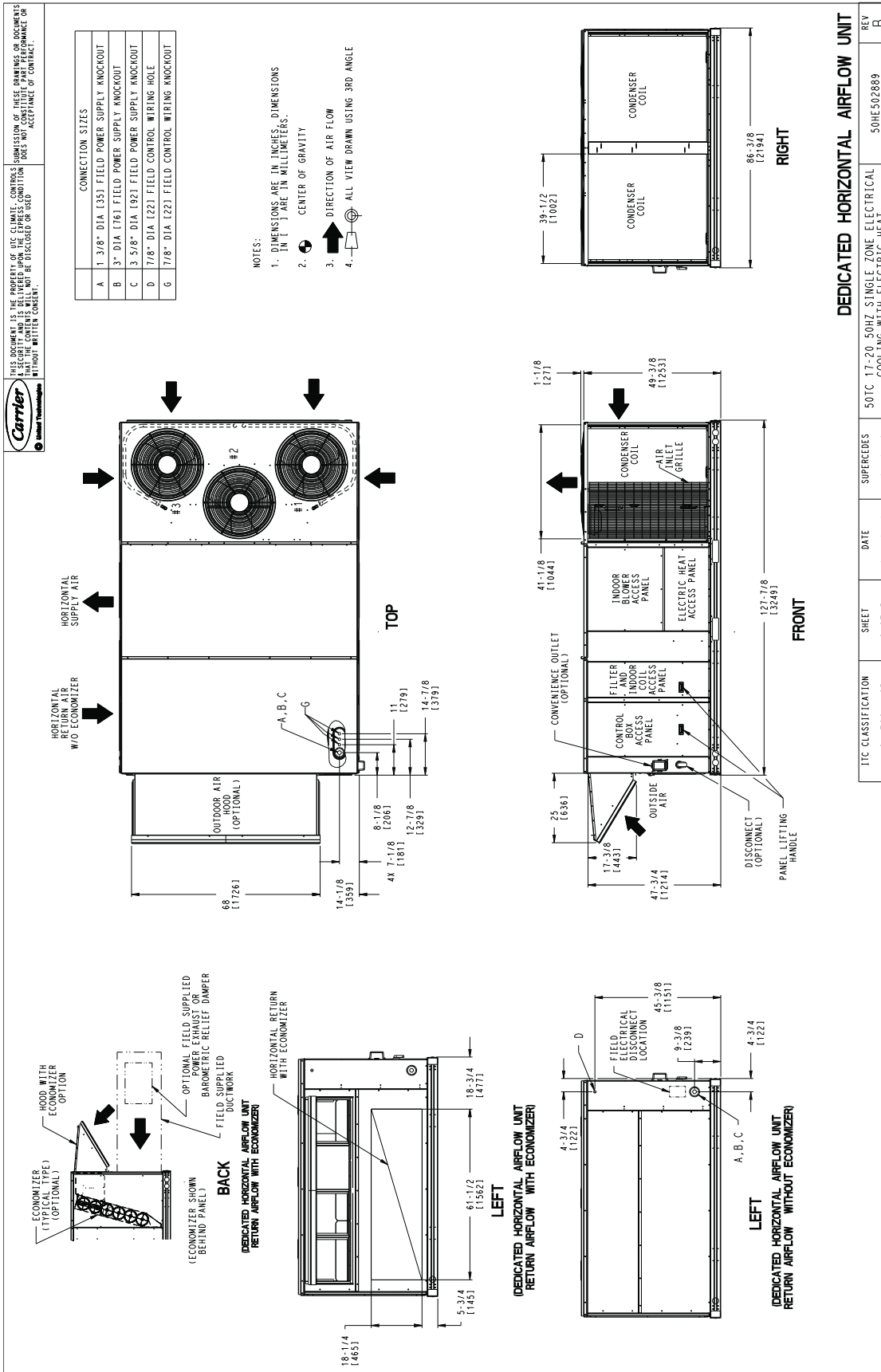

## DIMENSIONS 50TC-D17 AND 20 (cont)

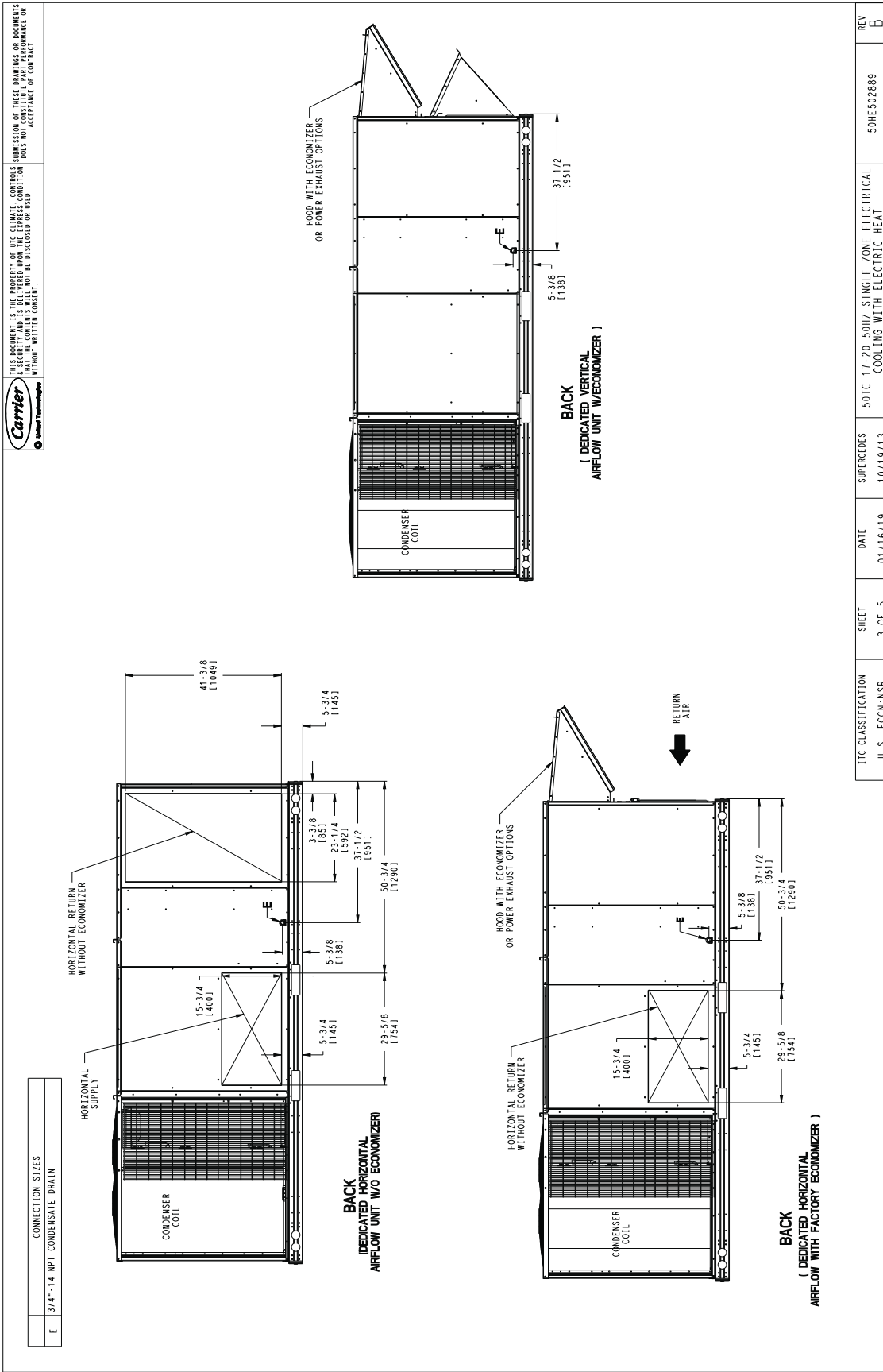

## DIMENSIONS 50TC-D17 AND 20 (cont)

**Carrier**  
Carrier Technologies

THIS DOCUMENT IS THE PROPERTY OF UIC CLIMATE CONTROLS. SUBMISSION OF THESE DRAWINGS OR DOCUMENTS TO ANY OTHER PARTY WITHOUT WRITTEN CONSENT OF UIC CLIMATE CONTROLS DOES NOT CONSTITUTE AN ACCEPTANCE OF CONTRACT.

UNIT	CORNER A		CORNER B		CORNER C		CORNER D		C.G.							
	WEIGHT * LBS.	WEIGHT (A) KG.	WEIGHT (B) LBS.	WEIGHT (C) KG.	WEIGHT (D) LBS.	WEIGHT (E) KG.	X	Y	Z	Z						
50TC17	1808	822	415	189	492	224	488	222	412	187	42	29/32 [1090]	69	7/4 [1759]	16	1/2 [419]
50TC20	1823	829	419	190	496	226	493	224	415	189	42	29/32 [1090]	69	7/4 [1759]	16	1/2 [419]

\* STANDARD UNIT WEIGHT IS WITHOUT ELECTRIC HEAT AND WITHOUT PACKAGING. FOR OTHER OPTIONS AND ACCESSORIES, REFER TO THE PRODUCT DATA CATALOG.

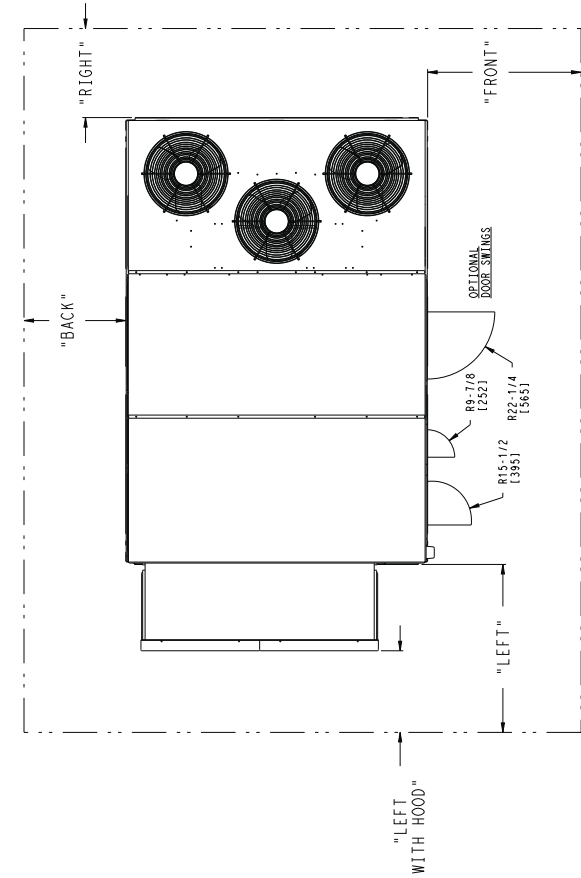

- NOTES:
- CLEARANCE ABOVE THE UNIT TO BE 72"
  - FOR ALL MINIMUM CLEARANCES LOCAL CODES OR JURISDICTIONS MAY PREVAIL.

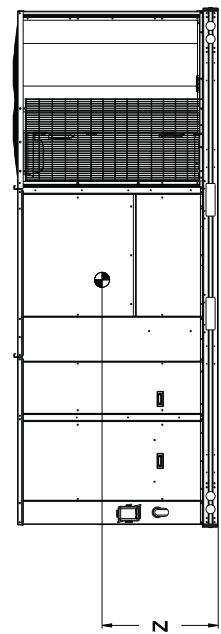

SURFACE	CLEARANCE		OPERATING CLEARANCE
	SERVICE WITH CONDUCTIVE BARRIER	SERVICE WITH NONCONDUCTIVE BARRIER	
FRONT	48 [1219mm]	36 [914mm]	18 [457mm]
LEFT	48 [1219mm]	42 [1067mm]	18 [457mm]
BACK	42 [1067mm]	36 [914mm]	18 [457mm]
LEFT WITH HOOD	36 [914mm]	36 [914mm]	18 [457mm]
RIGHT	36 [914mm]	36 [914mm]	18 [457mm]
TOP	72 [1829mm]	72 [1829mm]	72 [1829mm]

IUC CLASSIFICATION	SHEET	DATE	REV
U.S. ECCN: NSR	4 OF 5	01/16/19	B
SUPERCEDES		50TC	50HE502889
17-20 50HZ SINGLE ZONE ELECTRICAL COOLING WITH ELECTRIC HEAT			

## DIMENSIONS 50TC-D17 AND 20 (cont)

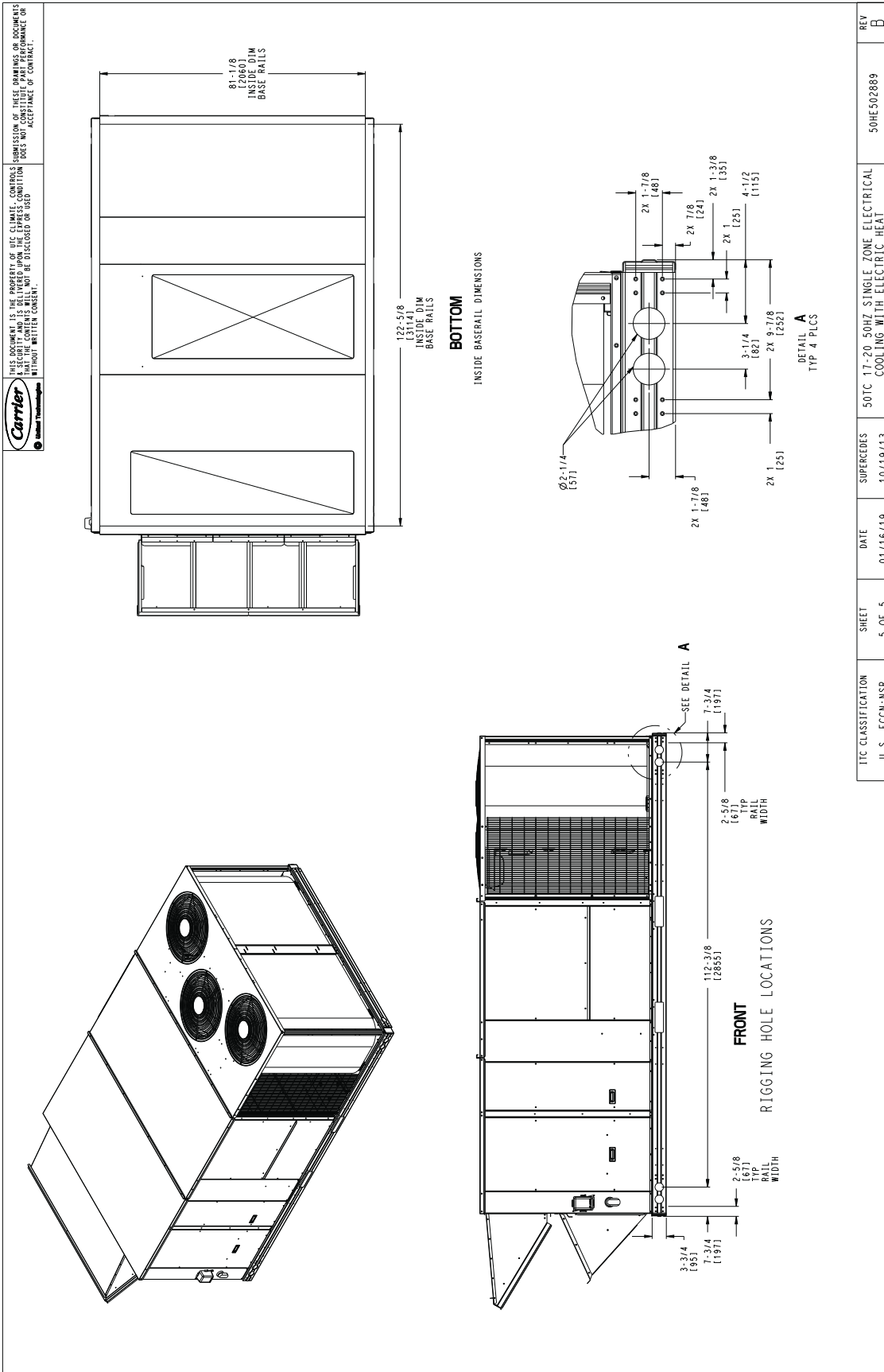

## DIMENSIONS 50TC-D24 AND 28

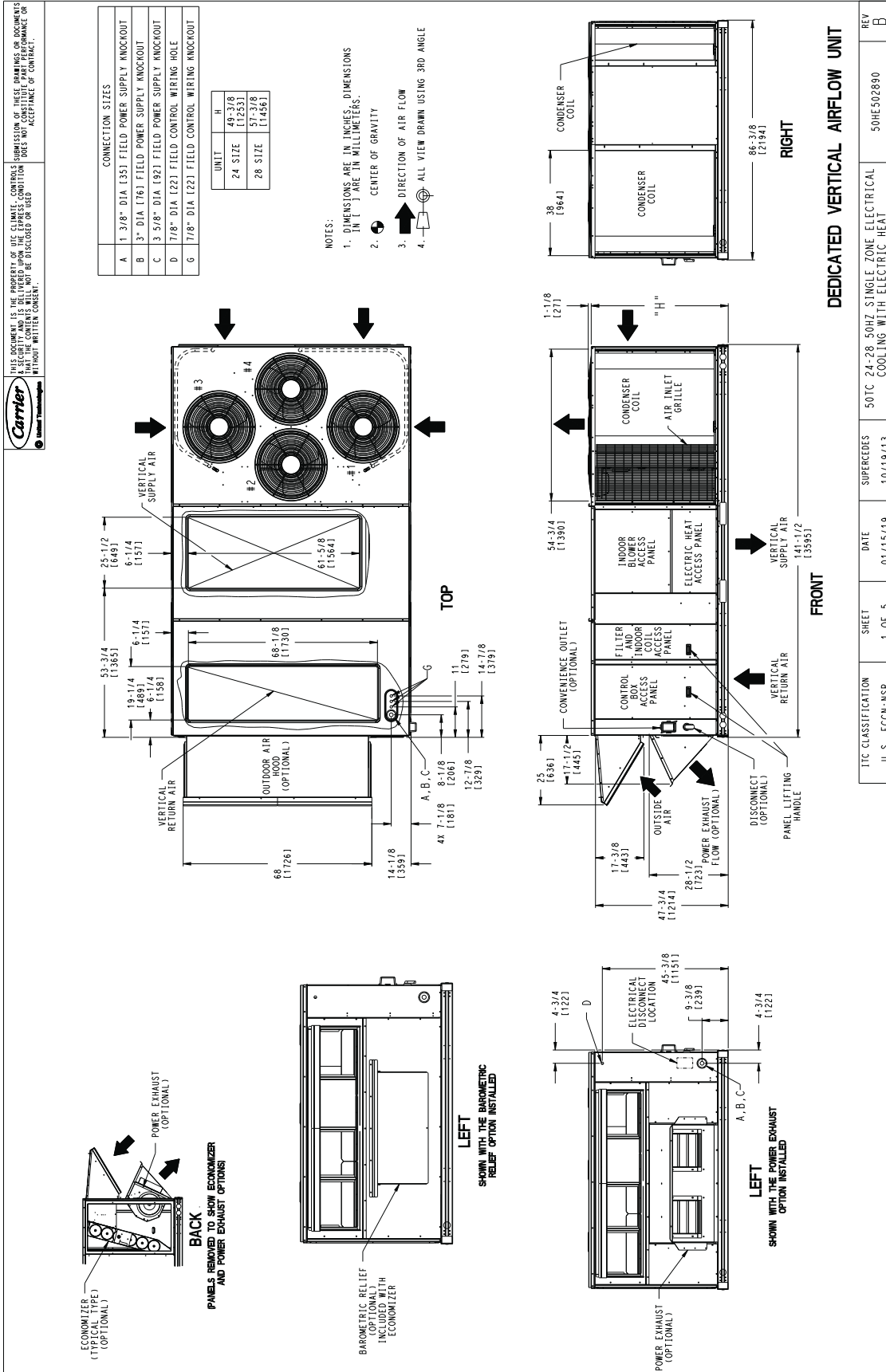

## DIMENSIONS 50TC-D24 AND 28 (cont)

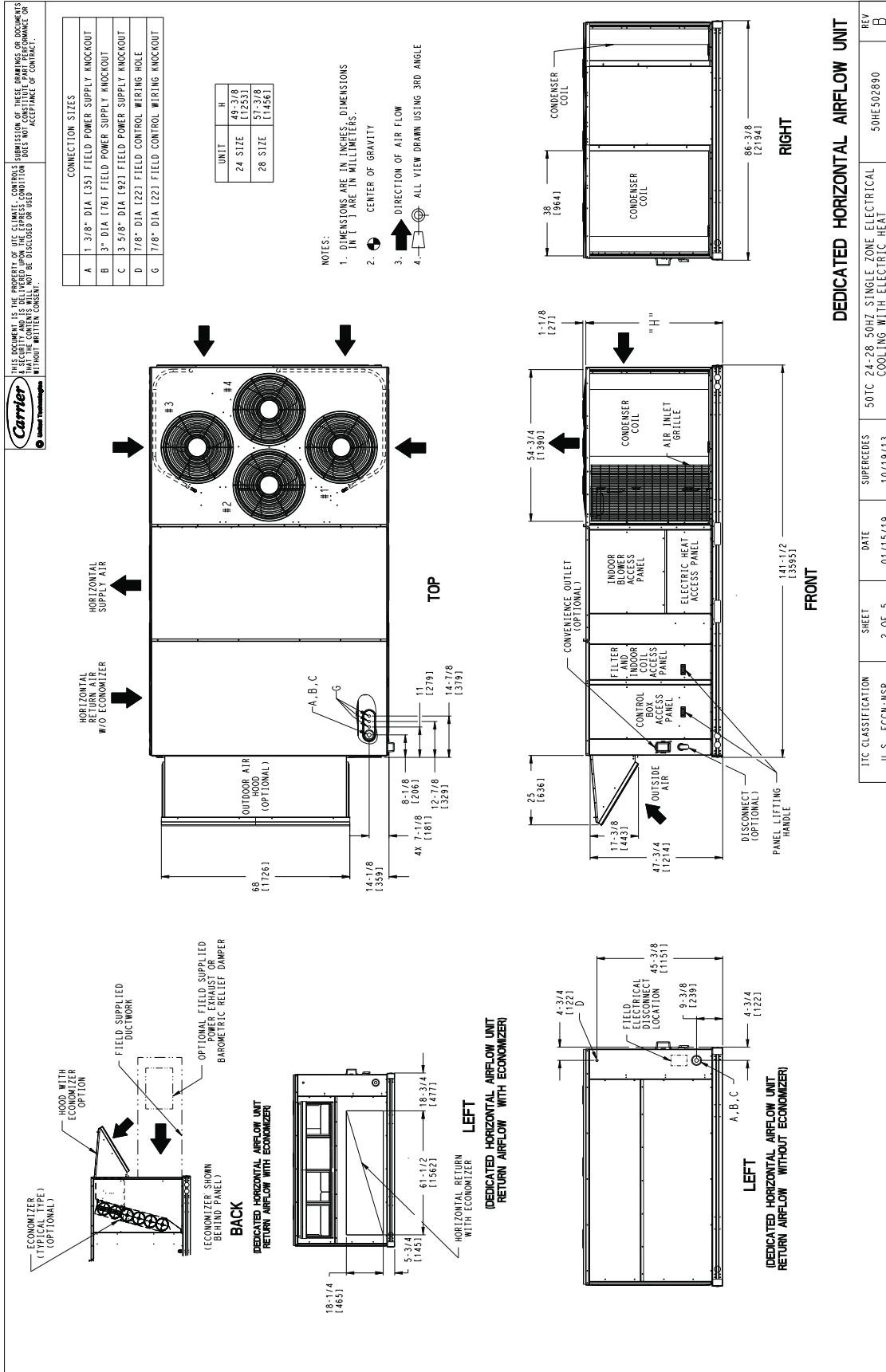

**DEDICATED HORIZONTAL AIRFLOW UNIT**

TIC CLASSIFICATION	SHEET	DATE	SUPERCEDES	REV
U.S. - ECCN: NSR	2 OF 5	01/15/19	10/19/13	B
50TC 24-28 50HZ SINGLE ZONE ELECTRICAL COOLING WITH ELECTRIC HEAT			50HE502890	

## DIMENSIONS 50TC-D24 AND 28 (cont)

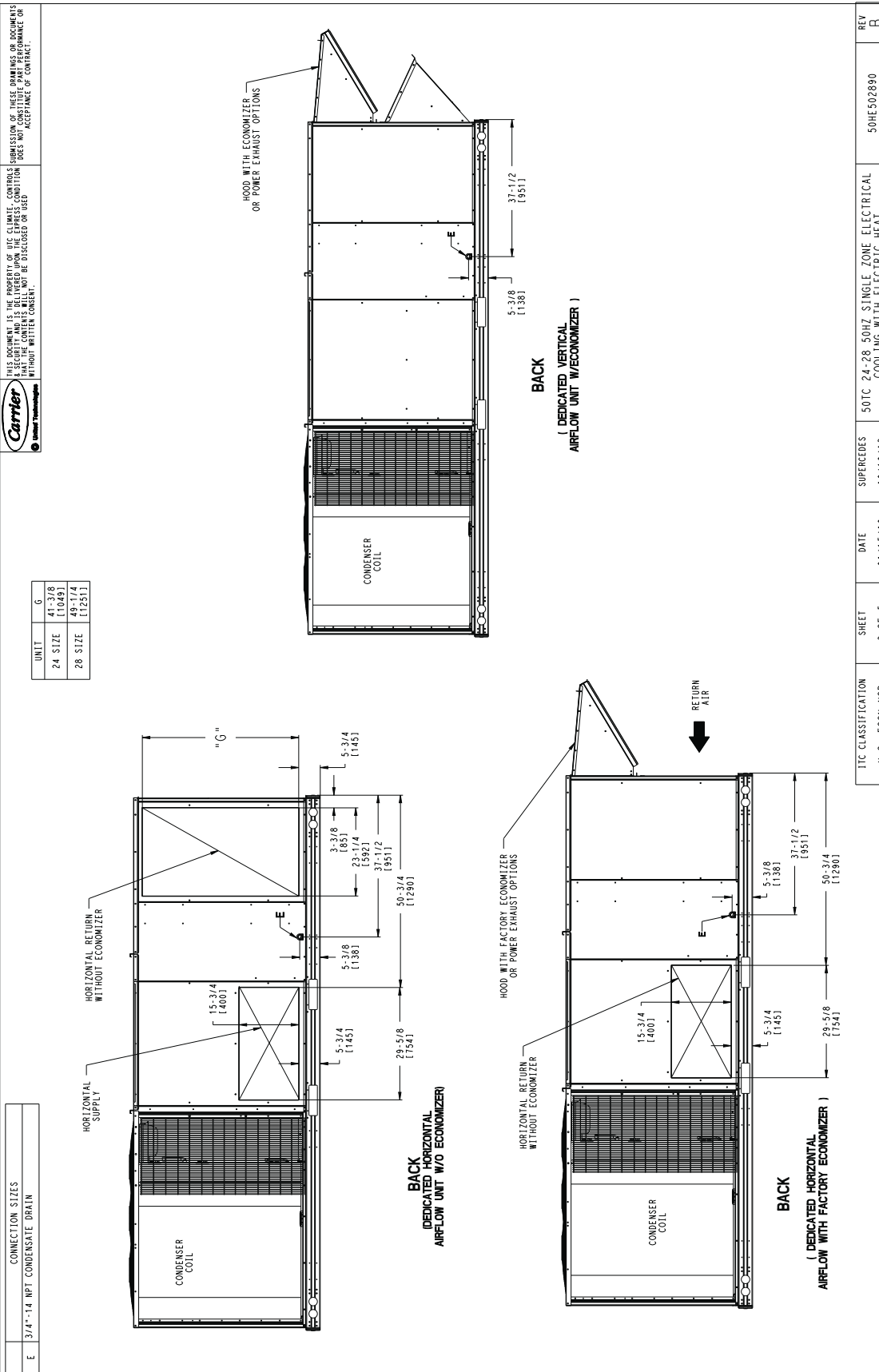

REV	B
50HE-502890	
50TC 24-28 50HZ SINGLE ZONE ELECTRICAL COOLING WITH ELECTRIC HEAT	
SUPERCEDES	10/19/13
DATE	01/15/19
SHEET	3 OF 5
ITC CLASSIFICATION	U.S. ECCN: NSR



## DIMENSIONS 50TC-D24 AND 28 (cont)

**Carrier**  
THIS DOCUMENT IS THE PROPERTY OF UTC CLIMATE CONTROLS. PERMISSION OF THESE DRAWINGS OR DOCUMENTS IS SECURITY AND IS DELIVERED UPON THE EXPRESS CONDITION DOES NOT CONSTITUTE PART PERFORMANCE OR WITHOUT WRITTEN CONSENT.

UNIT	CORNER WEIGHT (A)		CORNER WEIGHT (B)		CORNER WEIGHT (C)		CORNER WEIGHT (D)		C.G.						
	LBS.	KG.	LBS.	KG.	LBS.	KG.	LBS.	KG.	X	Y	Z				
50TC24	1973	897	532	242	522	237	456	207	464	211	40	5/32 [1020]	70 [1778]	16	1/2 [419]
50TC28	2098	954	545	248	539	245	504	229	510	232	41	21/32 [1058]	70 1/4 [1784]	19	[483]

\* STANDARD UNIT WEIGHT IS WITHOUT ELECTRIC HEAT AND WITHOUT PACKAGING.  
 FOR OTHER OPTIONS AND ACCESSORIES, REFER TO THE PRODUCT DATA CATALOG.

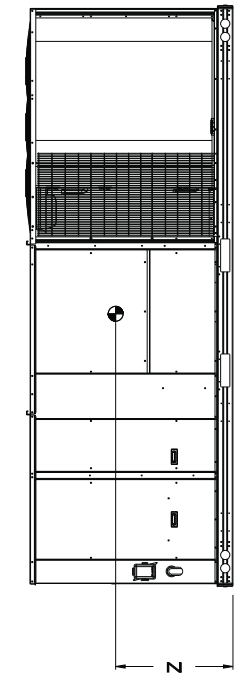
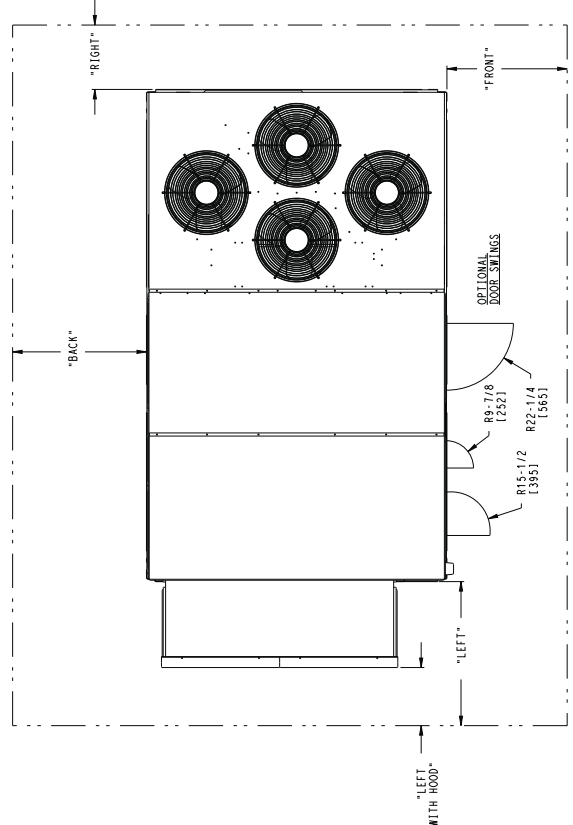

- NOTES:
1. CLEARANCE ABOVE THE UNIT TO BE 72"
  2. FOR ALL MINIMUM CLEARANCES LOCAL CODES OR JURISDICTIONS MAY PREVAIL.

SURFACE	CLEARANCE		OPERATING	
	WITH CONDUCTIVE BARRIER	WITH NONCONDUCTIVE BARRIER	WITH CONDUCTIVE BARRIER	WITH NONCONDUCTIVE BARRIER
FRONT	48 [1219mm]	36 [914mm]	18 [457mm]	18 [457mm]
LEFT	48 [1219mm]	42 [1067mm]	18 [457mm]	18 [457mm]
BACK	42 [1067mm]	36 [914mm]	18 [457mm]	18 [457mm]
RIGHT	36 [914mm]	36 [914mm]	18 [457mm]	18 [457mm]
TOP	72 [1829mm]	72 [1829mm]	72 [1829mm]	72 [1829mm]

ITC CLASSIFICATION	SHEET	DATE	REV
U.S. ECCN: NSR	4 OF 5	01/15/19	B
SUPERCEDES			50HE502890
50TC 24-28 50HZ SINGLE ZONE ELECTRICAL COOLING WITH ELECTRIC HEAT			

## DIMENSIONS 50TC-D24 AND 28 (cont)

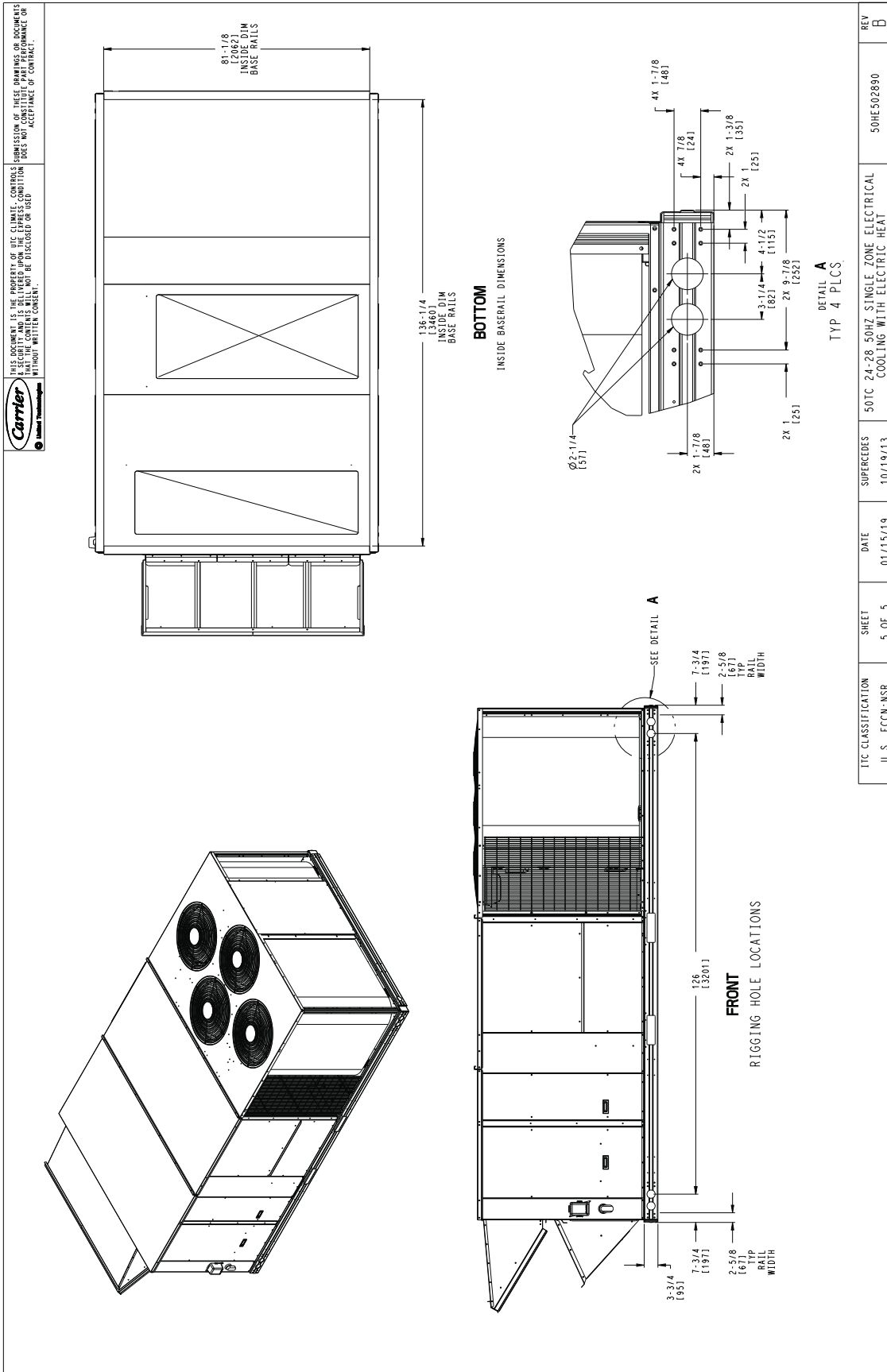

## DIMENSIONS 50TC-D30

**Carrier**  
THIS DOCUMENT IS THE PROPERTY OF UTC CLIMATE CONTROLS. IT IS TO BE USED FOR THE PROJECT AND IS TO BE RETURNED TO THE SUPPLIER UPON THE EXPRESS CONDITION THAT IT IS NOT TO BE REPRODUCED OR COPIED IN ANY MANNER WITHOUT WRITTEN CONSENT.

CONNECTION SIZES	
A	1-3/8" DIA [135] FIELD POWER SUPPLY KNOCKOUT
B	3" DIA [76] FIELD POWER SUPPLY KNOCKOUT
C	3-5/8" DIA [92] FIELD POWER SUPPLY KNOCKOUT
D	7/8" DIA [22] FIELD CONTROL WIRING HOLE
G	7/8" DIA [22] FIELD CONTROL WIRING KNOCKOUT

- NOTES:
1. DIMENSIONS ARE IN INCHES. DIMENSIONS IN  $\square$  ARE IN MILLIMETERS.
  2. CENTER OF GRAVITY
  3. DIRECTION OF AIR FLOW
  4. ALL VIEW DRAWN USING 3RD ANGLE

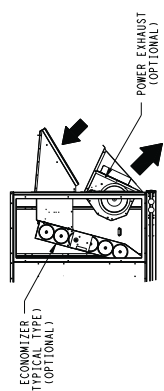
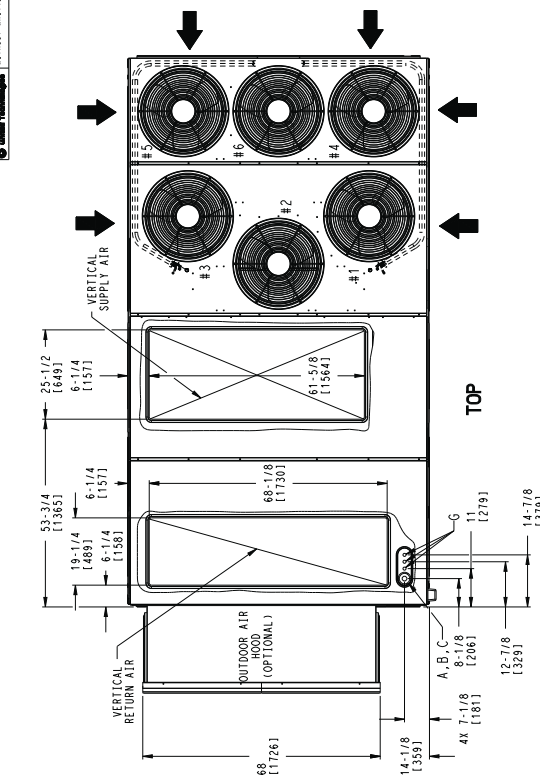

**BACK**  
 PANELS REMOVED TO SHOW ECONOMIZER AND POWER EXHAUST OPTIONS

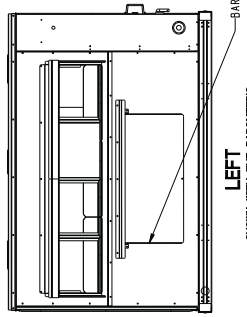

**LEFT**  
 SHOWN WITH THE BAROMETRIC RELIEF OPTION INSTALLED

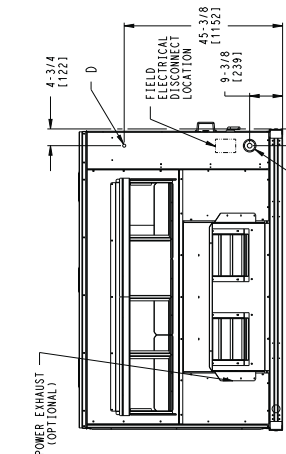

**LEFT**  
 SHOWN WITH THE POWER EXHAUST OPTION INSTALLED

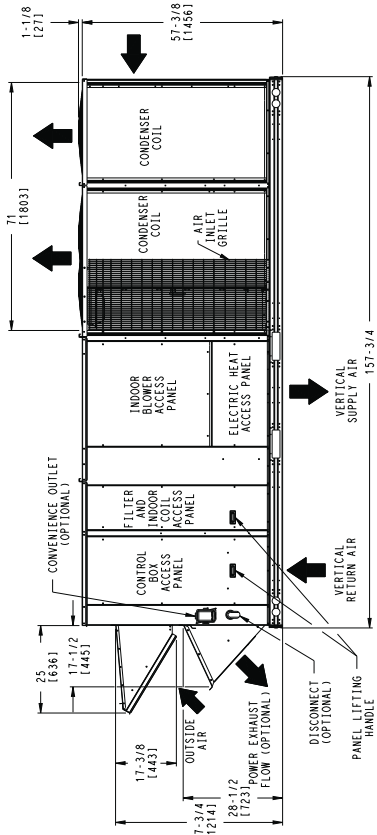

**FRONT**

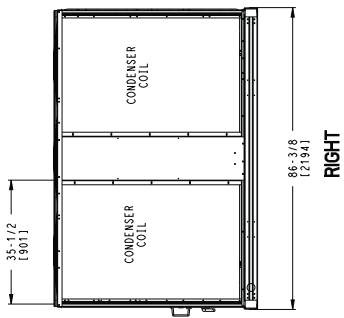

**RIGHT**

### DEDICATED VERTICAL AIRFLOW UNIT 30 SIZE

TIC CLASSIFICATION	SHEET	DATE	SUPERCEDES	REV
U.S. ECCN: NSR	1 OF 5	01/17/19	10/09/13	C
50TC 29.30 SINGLE ZONE ELECTRICAL COOLING WITH ELECTRIC HEAT				50HE502175

## DIMENSIONS 50TC-D30 (cont)

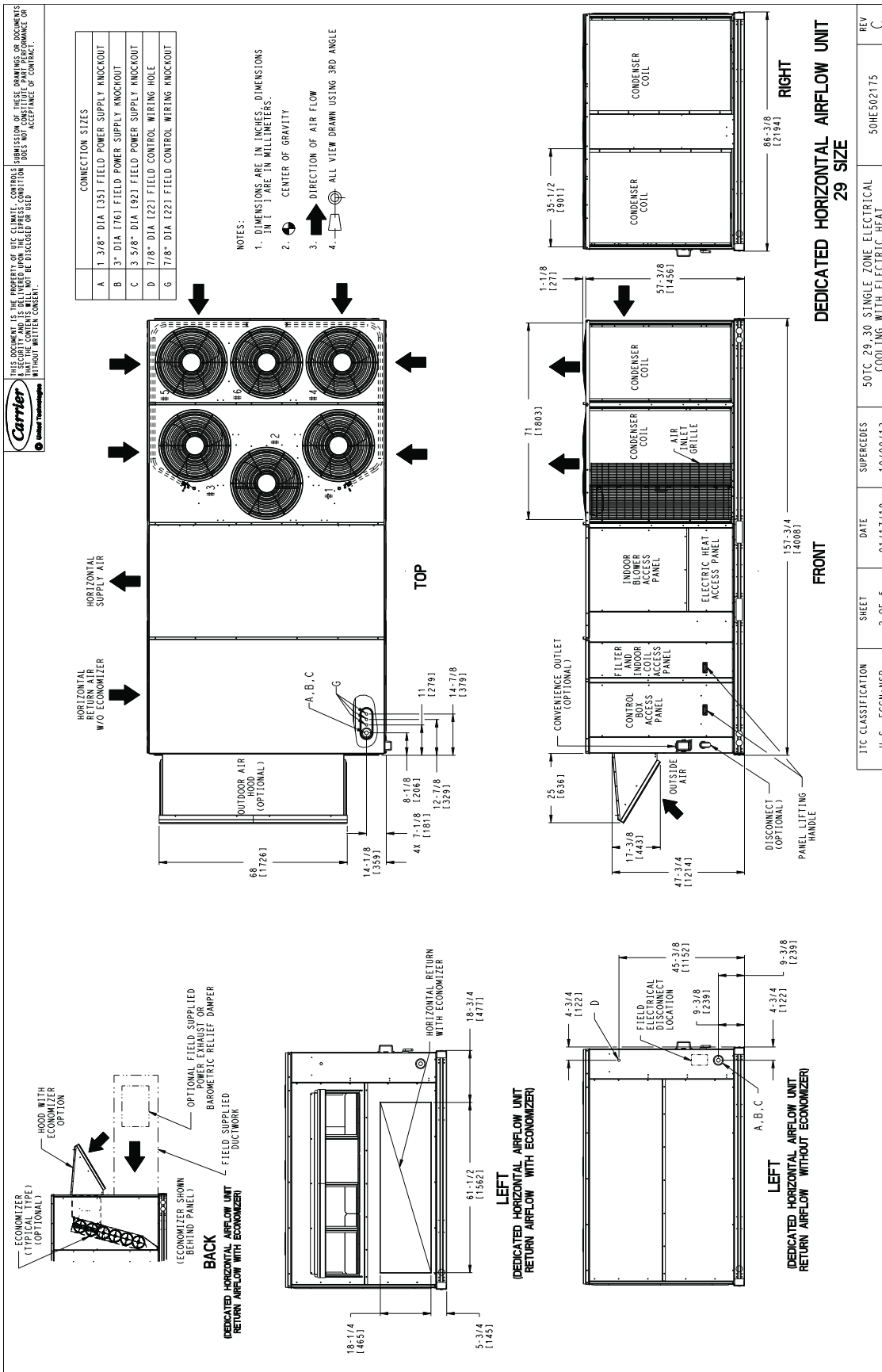

## DIMENSIONS 50TC-D30 (cont)

**Carrier**  
© Carrier Technologies

THIS DOCUMENT IS THE PROPERTY OF ITC CLIMATE CONTROLS. REPRODUCTION OF THESE DRAWINGS OR DOCUMENTS IS STRICTLY PROHIBITED. THIS DOCUMENT IS TO BE USED FOR INFORMATION ONLY AND DOES NOT CONSTITUTE PART PERFORMANCE OR WARRANTY. ANY INFORMATION NOT BEING DISCLOSED OR USED WITHOUT WRITTEN CONSENT.

**BACK**  
( DEDICATED VERTICAL AIRFLOW UNIT W/ ECONOMIZER )  
30 SIZE

**BACK**  
( DEDICATED HORIZONTAL AIRFLOW UNIT W/O ECONOMIZER )  
29 SIZE

**BACK**  
( DEDICATED HORIZONTAL AIRFLOW UNIT WITH FACTORY ECONOMIZER )  
29 SIZE

REV C

50HE502175

50TC 29, 30 SINGLE ZONE ELECTRICAL COOLING WITH ELECTRIC HEAT

SUPERCEDES 10/09/13

DATE 01/17/19

SHEET 3 OF 5

ITC CLASSIFICATION U.S. - ECCN: NSR

E	CONNECTION SIZES	
	3/4" - 1/4" NPT CONDENSATE DRAIN	

## DIMENSIONS 50TC-D30 (cont)

**Carrier**  
Carrier Technologies

THIS DOCUMENT IS THE PROPERTY OF CARRIER. CARRIER'S SUBMISSION OF THESE DRAWINGS OR DOCUMENTS IS A CONDITION AND IS BASED UPON THE EXPRESS CONDITION THAT THE CONTENTS WILL NOT BE DISCLOSED OR USED WITHOUT WRITTEN CONSENT.

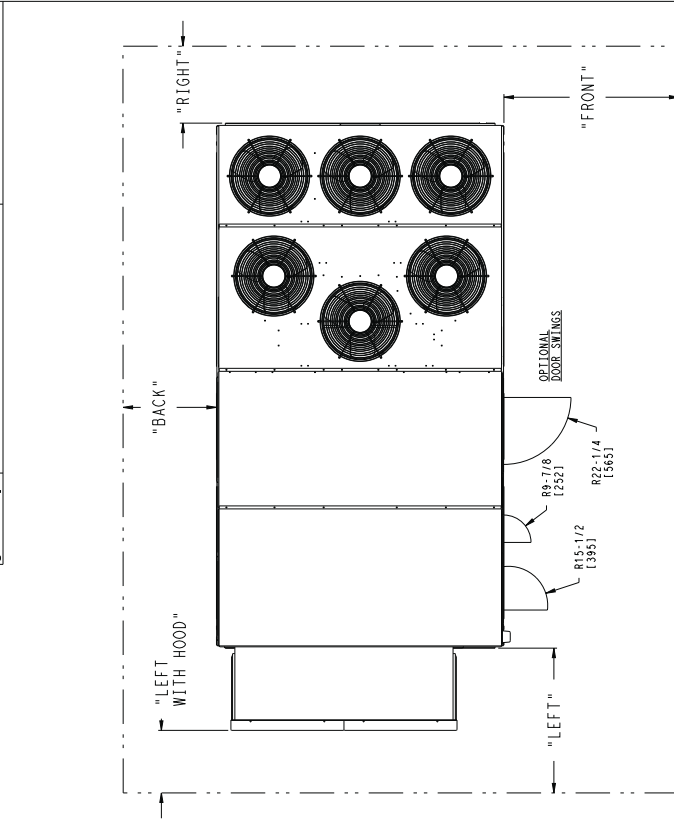

NOTES:  
 1. CLEARANCE ABOVE THE UNIT TO BE 72"  
 2. FOR ALL MINIMUM CLEARANCES LOCAL CODES OR JURISDICTIONS MAY PREVAIL.

SURFACE	CLEARANCE		OPERATING CLEARANCE
	SERVICE WITH CONDUCTIVE BARRIER	SERVICE WITH NONCONDUCTIVE BARRIER	
FRONT	48 [1219mm]	36 [914mm]	18 [457mm]
LEFT	48 [1219mm]	42 [1067mm]	18 [457mm]
BACK	42 [1067mm]	36 [914mm]	18 [457mm]
LEFT WITH HOOD	36 [914mm]	36 [914mm]	18 [457mm]
RIGHT	36 [914mm]	36 [914mm]	18 [457mm]
TOP	72 [1829mm]	72 [1829mm]	72 [1829mm]

UNIT	CORNER A		CORNER B		CORNER C		CORNER D		C.G.	
	WGT. LBS.	WGT. KG.	WGT. LBS.	WGT. KG.	WGT. LBS.	WGT. KG.	WGT. LBS.	WGT. KG.	X	Z
50TC29	2193	997	248	112	251	114	259	117	1172	19
50TC30	2513	1142	664	302	591	269	315	142	1172	19

\* STANDARD UNIT WEIGHT IS WITHOUT ELECTRIC HEAT AND WITHOUT PACKAGING. FOR OTHER OPTIONS AND ACCESSORIES, REFER TO THE PRODUCT DATA CATALOG.

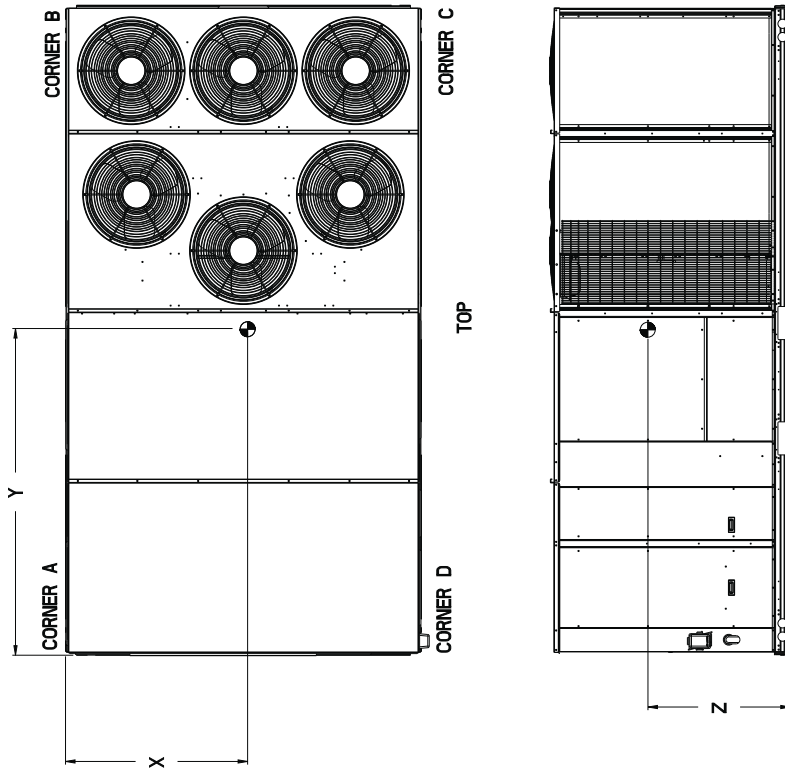

TIC CLASSIFICATION	SHEET	DATE	REV
U.S. - ECCN:NSR	4 OF 5	01/17/19	C

## DIMENSIONS 50TC-D30 (cont)

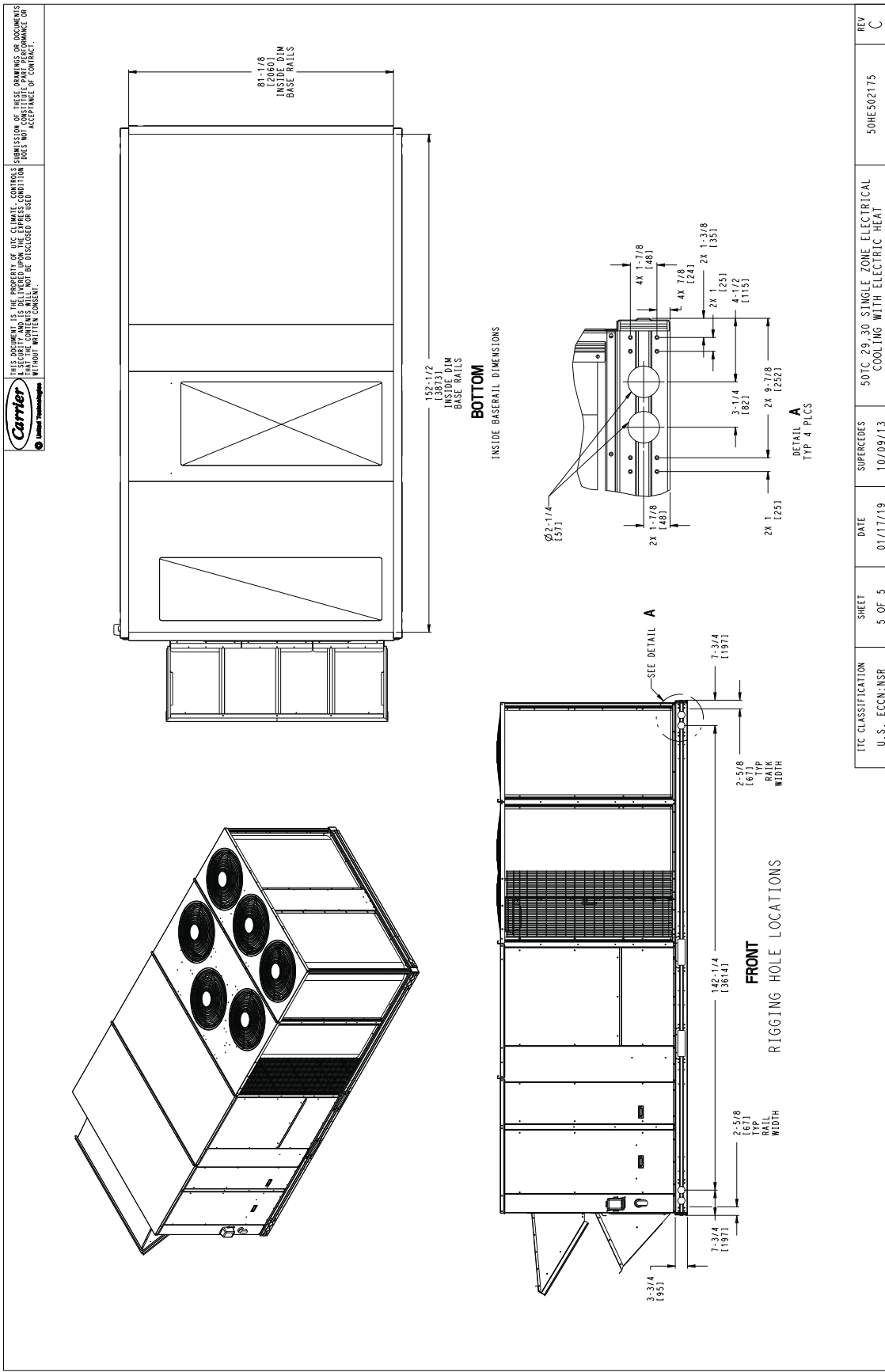

**Carrier**  
© Carrier Technologies

THIS DOCUMENT IS THE PROPERTY OF ITC CLIMATE CONTROLS. REPRODUCTION OF THESE DRAWINGS OR DOCUMENTS IS STRICTLY PROHIBITED. SECURITY AND IS DELIVERED UPON THE EXPRESS CONDITION THAT IT IS NOT TO BE DISCLOSED OR USED IN ANY MANNER WITHOUT WRITTEN CONSENT.

## ROOFCURB DETAILS 50TC-D17 AND 20

UNIT SIZE	"A"	ROOF CURB ACCESSORY
17,20	1'-2" [356.0] 2'-0" [610.0]	CRRFCURB045A00 CRRFCURB046A00

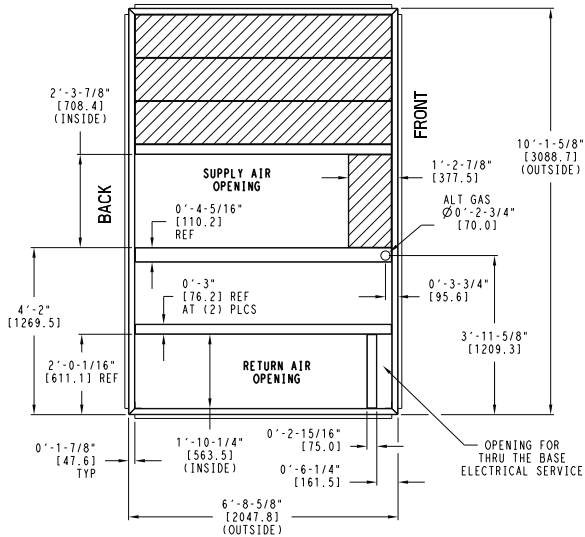

NOTES:

- 1 ROOF CURB ACCESSORY IS SHIPPED UNASSEMBLED.
- 2 DIMENSIONS IN [ ] ARE IN MILLIMETERS.
- 3 ROOF CURB GALVANIZED STEEL.
- 4 ATTACH DUCTWORK TO CURB (FLANGES ON DUCT REST ON CURB)
- 5 SERVICE CLEARANCE 4 FT ON EACH SIDE

➔ DIRECTION OF AIR FLOW

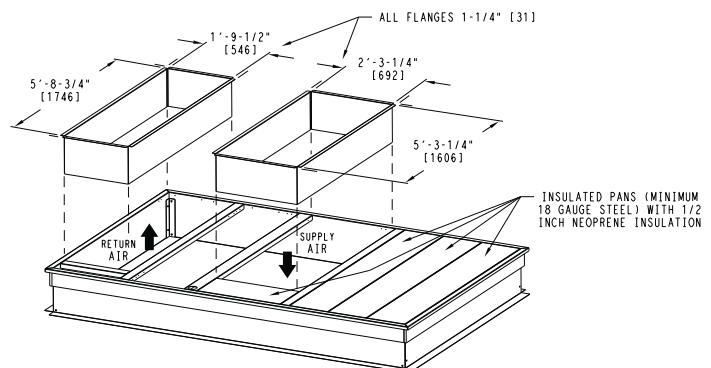
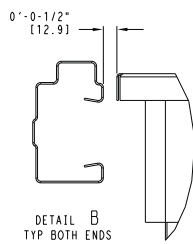
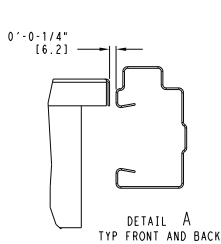
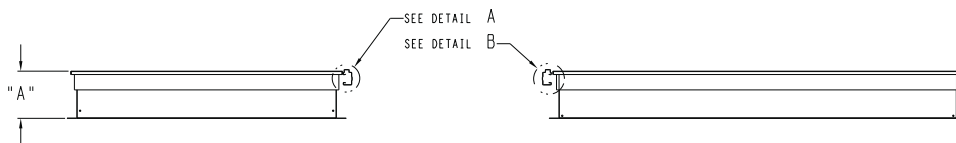
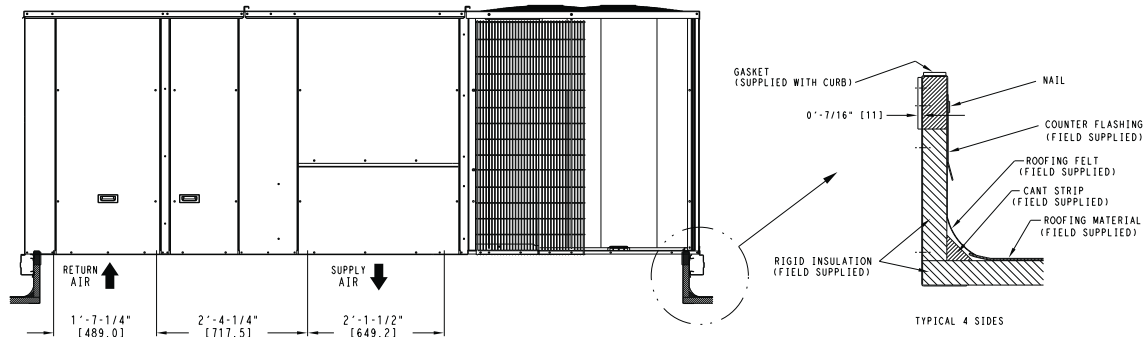
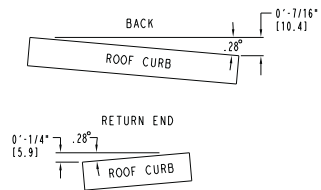



## ROOFCURB DETAILS 50TC-D24 AND 28

UNIT SIZE	"A"	ROOF CURB ACCESSORY
24, 28	1'-2" [356.0] 2'-0" [610.0]	CRRFCURB047A00 CRRFCURB048A00

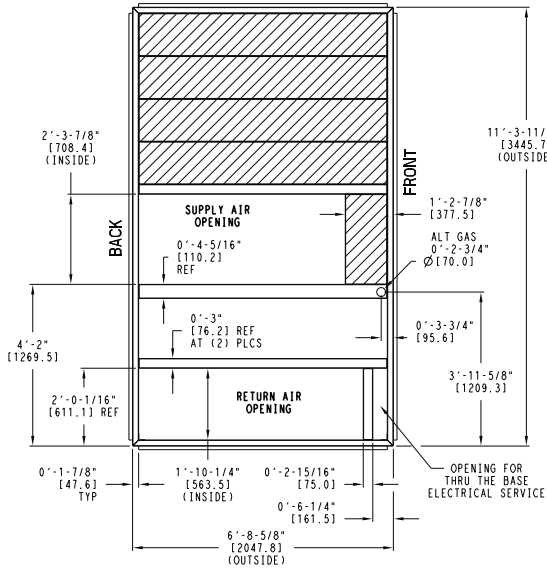

- NOTES:
- 1 ROOF CURB ACCESSORY IS SHIPPED UNASSEMBLED.
  - 2 DIMENSIONS IN [ ] ARE IN MILLIMETERS.
  - 3 ROOF CURB GALVANIZED STEEL.
  - 4 ATTACH DUCTWORK TO CURB (FLANGES ON DUCT REST ON CURB)
  - 5 SERVICE CLEARANCE 4 FT ON EACH SIDE

➔ DIRECTION OF AIR FLOW

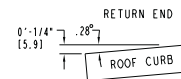
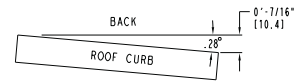

MAX CURB LEVELING TOLERANCES

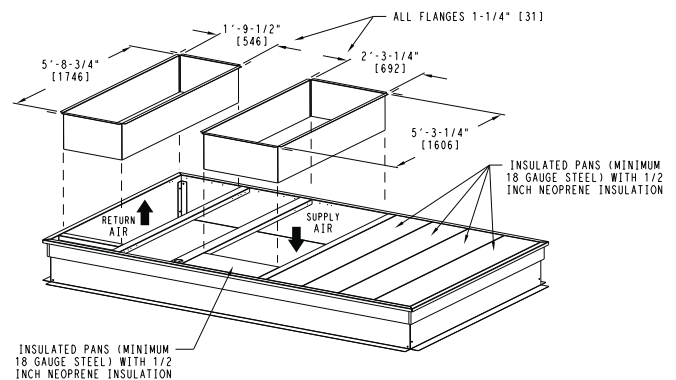
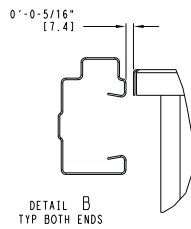
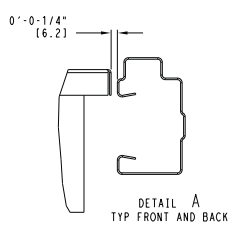
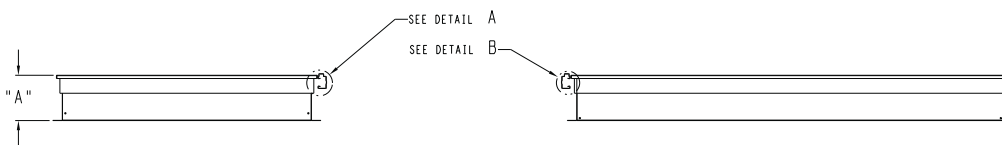
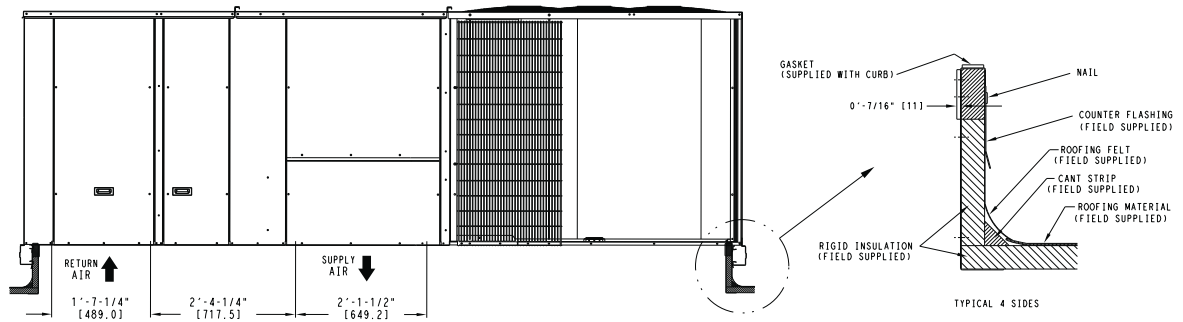

## ROOFCURB DETAILS 50TC-D30

UNIT SIZE	"A"	ROOF CURB ACCESSORY
30	1'-2" [356.0] 2'-0" [610.0]	CRRFCURB049A00 CRRFCURB050A00

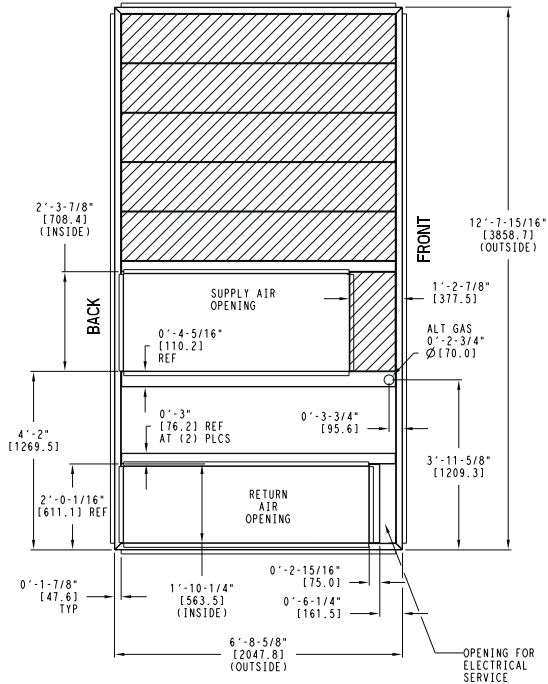

- NOTES:
- 1 ROOF CURB ACCESSORY IS SHIPPED UNASSEMBLED.
  - 2 BOLT HEADS TO BE ON INSIDE OF FLANGE. CLEARANCE IS (11) 0-0-7/16" TYP ALL CORNERS.
  - 3 DIMENSIONS IN [ ] ARE IN MILLIMETERS.
  - 4 ROOF CURB GALVANIZED STEEL.
  - 5 ATTACH DUCTWORK TO CURB (FLANGES ON DUCT REST ON CURB)
  - 6 SERVICE CLEARANCE 4 FT ON EACH SIDE
- ➔ DIRECTION OF AIR FLOW

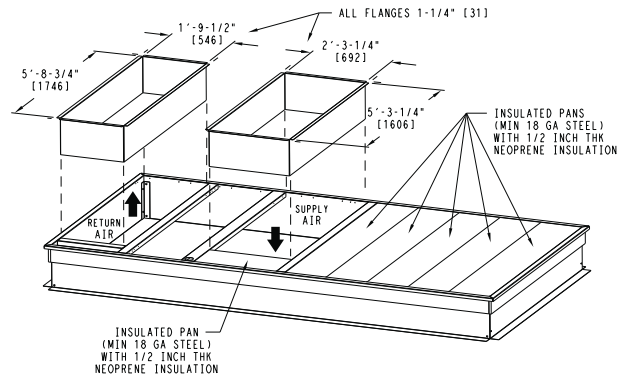
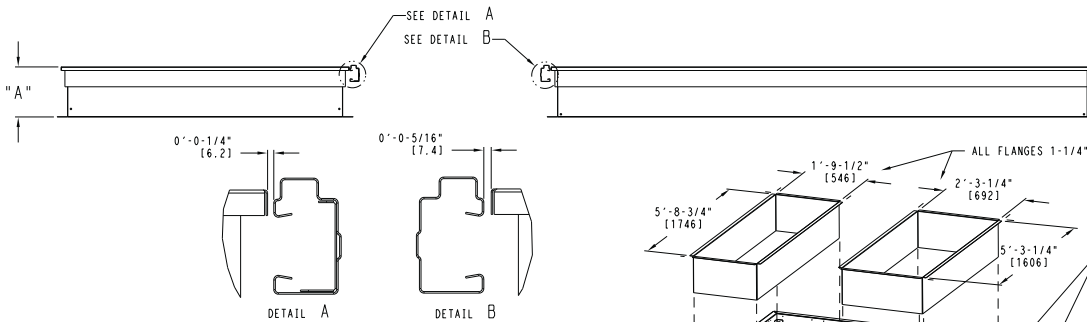
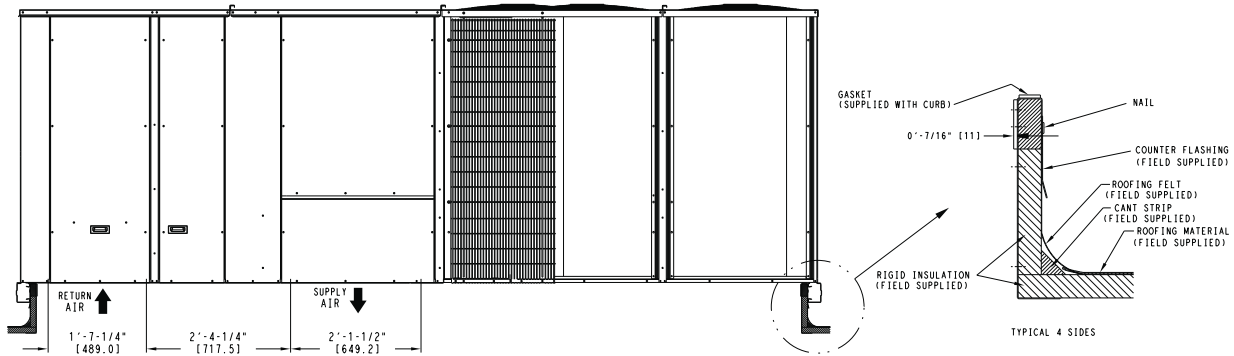
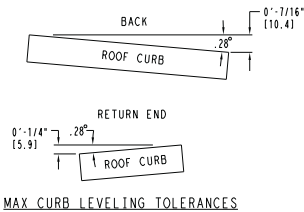

## OPTIONS AND ACCESSORIES WEIGHT ADDERS

BASE UNIT WITH OPTIONS AND ACCESSORIES (Weight Adders)	MAX WEIGHT ADD									
	50TC*17		50TC*20		50TC*24		50TC*28		50TC*30	
	kg	lb	kg	lb	kg	lb	kg	lb	kg	lb
Standard Unit Weight	822	1808	829	1823	897	1973	954	2098	1142	2513
Power Exhaust	57	125	57	125	57	125	57	125	57	125
Economizer	77	170	77	170	77	170	88	195	88	195
Copper Tube/Fin Evaporator Coil	50	110	50	110	61	135	73	161	78	173
Electric Heater	39	85	39	85	39	85	39	85	39	85
Single Point Kit	7	15	7	15	7	15	7	15	7	15
Roof Curb 14-in. (356mm)	95	210	95	210	112	246	112	246	122	270
Roof Curb 24-in. (610mm)	132	290	132	290	140	308	140	308	155	342
Louvered Hail Guard	27	60	27	60	54	120	61	135	68	150
CO <sub>2</sub> sensor	2	5	2	5	2	5	2	5	2	5
Return Smoke Detector	2	5	2	5	2	5	2	5	2	5
Supply Smoke Detector	2	5	2	5	2	5	2	5	2	5
Fan/Filter Status Switch	1	2	1	2	1	2	1	2	1	2
Non-Fused Disconnect	7	15	7	15	7	15	7	15	7	15
Enthalpy Sensor	1	2	1	2	1	2	1	2	1	2
Differential Enthalpy Sensor	1	3	1	3	1	3	1	3	1	3
Two Position Motorized Damper	23	50	23	50	23	50	29	65	29	65
Manual Damper	16	35	16	35	16	35	18	40	18	40
Field Filter Track 4-in. (102mm)	5	12	5	12	5	12	5	12	5	12
MotorMaster Controller	16	35	16	35	16	35	16	35	16	35
Standard Static Motor/Drive	2	5	2	5	2	5	2	5	2	5
Medium Static Motor/Drive	2	5	3	6	3	6	3	6	5	10
High Static Motor/Drive	5	11	5	12	7	16	7	16	9	20

## ROOFCURB ADAPTER INFORMATION

For more installation information, refer to Installation Instructions, catalog number IIK-CRADCU04-01.

WHEN REPLACING PAST CARRIER MODEL*	USE ADAPTER CURB	WHEN REPLACING WITH NEW CARRIER MODEL
48/50TJ016-028	CRADCURB004A00	48/50TC17-28
48/50TM016-024		
48/50HJ015-017		
48/50DP012-020		
48/50DR012-016		
50PQ012-016		
48/50DR012-016		

\* Using curb similar to: CRRFCURB010A00, CRRFCURB011A00.

WHEN REPLACING PAST CARRIER MODEL*	USE ADAPTER CURB	WHEN REPLACING WITH NEW CARRIER MODEL
48/50TM028	CRADCURB005A00	48/50TC28

\* Using curb similar to: CRRFCURB025A00.

### AIR SIDE PRESSURE DROP

AIRFLOW		PRESSURE DROP	
L/s	CFM	Pa	(in. wg)
127	4500	94.6	.38
142	5000	94.6	.38
156	5500	97.1	.39
170	6000	97.1	.39
184	6500	99.6	.40
198	7000	99.6	.40
212	7500	102.1	.41
227	8000	102.1	.41
241	8500	104.6	.42
255	9000	107.1	.43
269	9500	109.6	.44
283	10000	112.1	.45
297	10500	114.6	.46
311	11000	117.1	.47
326	11500	119.6	.48
340	12000	122.1	.49
354	12500	124.5	.50

	A	WEIGHT
CRADCURB004A00	3089 mm (121.625")	175 kg (385 lbs.)
CRADCURB005A00	3445 mm (135.625")	193 kg (425 lbs.)

### ROOF CURB ADAPTER DIMENSIONS AND WEIGHT

	A	Weight
CRADCURB004A00	3089 mm (121.625")	175 kg (385 lbs.)
CRADCURB005A00	3445 mm (135.625")	193 kg (425 lbs.)

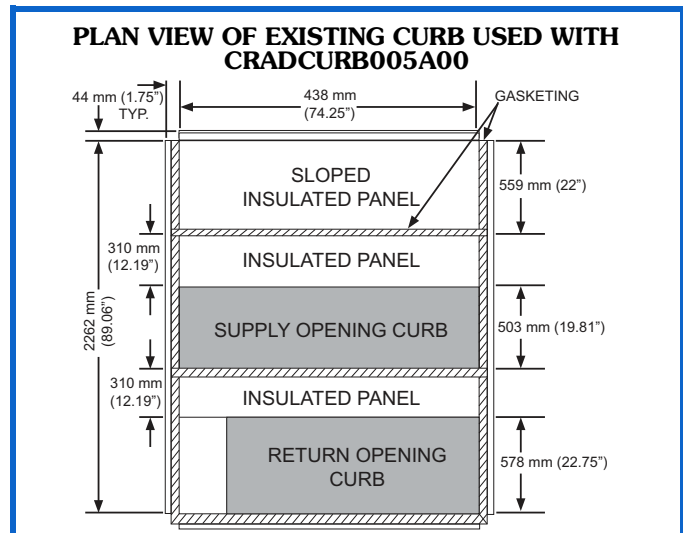
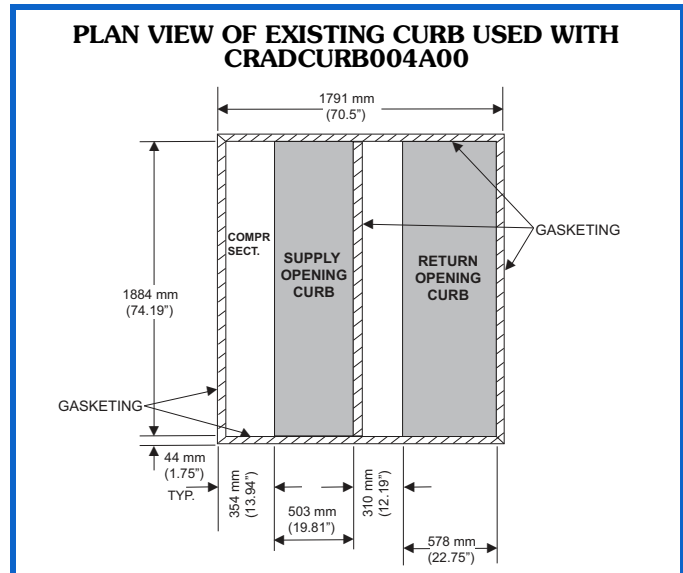
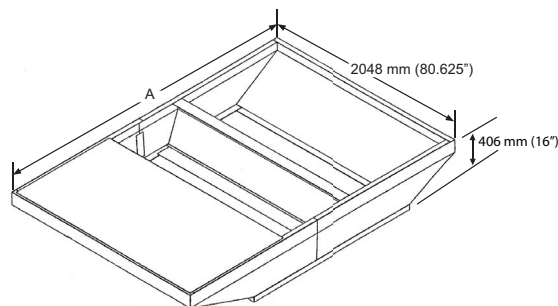

### OFFSET DIMENSIONS

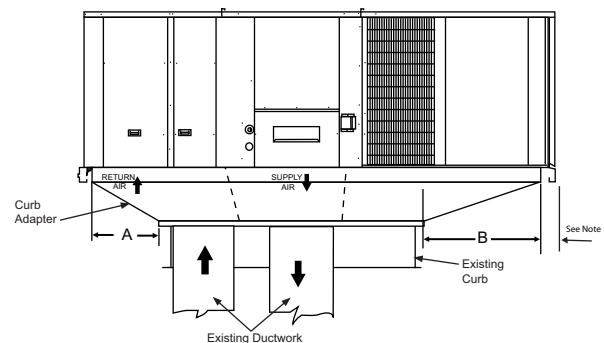

	A	B
CRADCURB004A00	527 mm (20.75")	772 mm (30.38")
CRADCURB005A00	425 mm (16.75")	679 mm (26.75")

NOTE: When the CRADCURB004A00 curb adapter is used with the 24/28 units, the unit will overhang the curb adapter by an additional 457 mm (18"). In the event the overhang is not acceptable, contact MicroMetl for additional curb adapter options.

## Min operating ambient temp (cooling)

In mechanical cooling mode, your Carrier rooftop can safely operate down to an outdoor ambient temperature of 4°C (40°F). It is possible to provide cooling at lower outdoor ambient temperatures by using less outside air, economizers, and/or accessory low ambient kits.

## Max operating ambient temp (cooling)

The maximum operating ambient temperature for cooling mode is 52°C (125°F). While cooling operation above 52°C (125°F) may be possible, it could cause either a reduction in performance, reliability, or a protective action by the unit's internal safety devices.

## Min and max airflow (cooling mode)

To maintain safe and reliable operation of your rooftop, operate within the cooling airflow limits. Operating above the max may cause blow-off, undesired airflow noise, or airflow related problems with the rooftop unit. Operating below the min may cause problems with coil freeze-up.

## Airflow

All units are draw-through in cooling mode.

## Outdoor air application strategies

Economizers reduce operating expenses and compressor run time by providing a free source of cooling and a means of ventilation to match application changing needs. In fact, they should be considered for most applications. Also, consider the various economizer control methods and their benefits, as well as sensors required to accomplish your application goals. Please contact your local Carrier representative for assistance.

## Motor limits, break horsepower (BHP)

Due to Carrier's internal unit design, air path, and specially designed motors, the full horsepower (maximum continuous BHP) band, as listed in Table 5, can be used with the utmost confidence. There is no need for extra safety factors, as Carrier's motors are designed and rigorously tested to use the entire, listed BHP range without either nuisance tripping or premature motor failure.

## Sizing a rooftop

Bigger isn't necessarily better. While an air conditioner needs to have enough capacity to meet the load, it doesn't need excess capacity. In fact, having excess capacity

typically results in very poor part load performance and humidity control.

Using higher design temperatures than ASHRAE recommends for your location, adding "safety factors" to the calculated load, and rounding up to the next largest unit, are all signs of oversizing air conditioners. Oversizing can cause short-cycling, and short cycling leads to poor humidity control, reduced efficiency, higher utility bills, drastic indoor temperature swings, excessive noise, and increased wear and tear on the air conditioner.

Rather than oversizing an air conditioner, wise contractors and engineers "right-size" or even slightly undersize air conditioners. Correctly sizing an air conditioner controls humidity better; promotes efficiency; reduces utility bills; extends equipment life, and maintains even, comfortable temperatures.

## Low ambient applications

When equipped with a Carrier economizer, your rooftop unit can cool your space by bringing in fresh, cool outside air. In fact, when so equipped, accessory low-ambient kit may not be necessary. In low ambient conditions, unless the outdoor air is excessively humid or contaminated, economizer-based "free cooling" is the preferred less costly and energy conscious method.

In low ambient applications where outside air might not be desired (such as contaminated or excessively humid outdoor environments), your Carrier rooftop can operate to ambient temperatures down to -29°C (-20°F) using the recommended accessory Motormaster low ambient controller.

## Winter start

Carrier's winter start kit extends the low ambient limit of your rooftop to -4°C (25°F). The kit bypasses the low pressure switch, preventing nuisance tripping of the low pressure switch. Other low ambient precautions may still be prudent.

## Application/Selection Option

Selection software by Carrier saves time by performing many of the steps above. Contact your Carrier sales representative for assistance.















## COOLING CAPACITIES 2-STAGE COOLING (SI)

50TC-D28				AMBIENT TEMPERATURE °C														
				29			35			41			46			52		
				EAT (db)			EAT (db)			EAT (db)			EAT (db)			EAT (db)		
2832 L/s	EAT (wb)	14	THC	64.4	64.4	72.7	60.6	60.6	68.4	56.6	56.6	63.9	52.4	52.4	59.1	47.9	47.9	54.1
			SHC	56.2	64.4	72.7	52.9	60.6	68.4	49.4	56.6	63.9	45.7	52.4	59.1	41.8	47.9	54.1
			kW	16.0			17.8			19.8			22.0			24.4		
3303 L/s	EAT (wb)	17	THC	68.6	68.6	69.5	63.5	63.5	67.0	58.2	58.2	64.4	52.7	52.7	61.3	48.0	48.0	56.2
			SHC	51.2	60.4	69.5	48.8	57.9	67.0	46.2	55.3	64.4	43.5	52.4	61.3	39.8	48.0	56.2
			kW	16.4			18.1			20.0			22.0			24.4		
3775 L/s	EAT (wb)	19	THC	76.6	76.6	76.6	71.5	71.5	71.5	65.9	65.9	65.9	60.1	60.1	60.1	53.8	53.8	53.8
			SHC	42.8	51.9	61.0	40.7	49.8	59.0	38.4	47.5	56.7	36.0	45.1	54.2	33.5	42.6	51.8
			kW	16.8			18.8			20.9			23.0			25.2		
4247 L/s	EAT (wb)	22	THC	83.3	83.3	83.3	79.3	79.3	79.3	74.2	74.2	74.2	68.4	68.4	68.4	62.1	62.1	62.1
			SHC	33.4	42.5	51.7	31.9	41.0	50.2	29.9	39.1	48.3	27.8	37.0	46.2	25.5	34.7	43.8
			kW	17.2			19.2			21.5			23.9			26.5		
4719 L/s	EAT (wb)	24	THC	—	88.3	88.3	—	84.3	84.3	—	79.9	79.9	—	74.6	74.6	—	68.7	68.7
			SHC	—	34.8	44.4	—	33.3	43.0	—	31.9	41.5	—	30.0	39.5	—	28.0	37.4
			kW	17.6			19.6			21.9			24.3			27.0		

<b>LEGEND</b>	— Do not operate	<b>kW</b> — Compressor kilowatts
<b>Cfm</b> — Cubic feet per minute (supply air)		<b>L/s</b> — Liters per second
<b>EAT(db)</b> — Entering air temperature (dry bulb)		<b>SHC</b> — Sensible heat capacity kW (Gross)
<b>EAT(wb)</b> — Entering air temperature (wet bulb)		<b>THC</b> — Total heat capacity kW (Gross)







## STATIC PRESSURE ADDERS (FACTORY OPTIONS AND/OR ACCESSORIES)

### ECONOMIZER — VERTICAL AND HORIZONTAL DUCT CONFIGURATION

SI																	
L/s	2124	2360	2596	2832	3067	3303	3539	3775	4011	4247	4483	4719	4955	5191	5427	5663	5899
Pa	12	13	14	15	17	18	19	20	22	23	24	26	27	28	30	31	33

### ELECTRIC HEATERS — VERTICAL AND HORIZONTAL DUCT CONFIGURATION

SI																	
L/s	2124	2360	2596	2832	3067	3303	3539	3775	4011	4247	4483	4719	4955	5191	5427	5663	5899
25 kW Heater	0.010	0.010	0.015	0.020	0.025	0.030	0.035	0.040	0.045	0.050	0.055	0.060	0.070	0.080	0.090	0.100	0.105
50 kW Heater	0.020	0.020	0.030	0.040	0.050	0.060	0.070	0.080	0.090	0.100	0.120	0.130	0.150	0.160	0.180	0.200	0.230
75 kW Heater	0.030	0.040	0.050	0.060	0.070	0.080	0.100	0.120	0.140	0.150	0.180	0.200	0.230	0.250	0.270	0.300	0.330

### ECONOMIZER — VERTICAL AND HORIZONTAL DUCT CONFIGURATION

ENGLISH																	
CFM	4500	5000	5500	6000	6500	7000	7500	8000	8500	9000	9500	10000	10500	11000	11500	12000	12500
in. wg	0.047	0.052	0.057	0.062	0.067	0.072	0.077	0.082	0.088	0.093	0.098	0.103	0.109	0.114	0.119	0.125	0.131

### ELECTRIC HEATERS — VERTICAL AND HORIZONTAL DUCT CONFIGURATION

ENGLISH								
L/s	4800	5000	6000	7000	8000	9000	10000	11500
25 kW Heater	0.011	0.012	0.019	0.028	0.038	0.050	0.064	0.089
50 kW Heater	0.022	0.024	0.038	0.056	0.077	0.102	0.130	0.179
75 kW Heater	0.032	0.036	0.057	0.084	0.116	0.153	0.195	0.268



## GENERAL FAN PERFORMANCE NOTES

1. Interpolation is permissible. Do not extrapolate.
2. External static pressure is the static pressure difference between the return duct and the supply duct plus the static pressure caused by any FIOPs or accessories.
3. Tabular data accounts for pressure loss due to clean filters, unit casing, and wet coils. Factory options and accessories may add static pressure losses. Selection software is available, through your salesperson, to help you select the best motor/drive combination for your application.
4. The Fan Performance tables offer motor/drive recommendations. In cases when two motor/drive combinations would work, Carrier recommended the lower horsepower option.
5. For information on the electrical properties of Carrier motors, please see the Electrical Information section of this book.
6. For more information on the performance limits of Carrier motors, see the Application Data section of this book.

## FAN PERFORMANCE 50TC-D17 VERTICAL SI

L/s	Available External Static Pressure (Pa)																			
	50		100		150		200		250		300		350		400		450		500	
	RPM	kW	RPM	kW	RPM	kW	RPM	kW	RPM	kW	RPM	kW	RPM	kW	RPM	kW	RPM	kW	RPM	kW
1675	398	0.27	504	0.42	590	0.58	666	0.75	733	0.93	795	1.12	853	1.31	907	1.51	958	1.72	1006	1.94
1793	410	0.31	513	0.47	598	0.64	673	0.82	740	1.00	801	1.20	858	1.40	912	1.61	962	1.82	1011	2.04
1911	422	0.35	522	0.52	606	0.70	680	0.88	747	1.08	808	1.28	864	1.49	917	1.70	968	1.92	1015	2.15
2029	434	0.40	532	0.58	615	0.76	688	0.96	754	1.16	814	1.37	870	1.58	923	1.80	973	2.03	1021	2.27
2147	447	0.45	543	0.64	624	0.83	696	1.04	761	1.24	821	1.46	877	1.68	929	1.91	979	2.15	1026	2.39
2265	460	0.51	553	0.71	633	0.91	704	1.12	769	1.34	828	1.56	884	1.79	936	2.02	985	2.27	1032	2.52
2383	473	0.57	565	0.78	643	0.99	713	1.21	777	1.43	836	1.66	891	1.90	942	2.14	991	2.39	1038	2.65
2501	487	0.64	576	0.86	653	1.08	722	1.30	785	1.54	843	1.77	898	2.02	949	2.27	998	2.53	1044	2.79
2619	500	0.71	588	0.94	664	1.17	732	1.40	794	1.64	851	1.89	906	2.14	956	2.40	1005	2.67	1051	2.94
2737	515	0.79	600	1.03	674	1.27	741	1.51	803	1.76	860	2.02	913	2.28	964	2.54	1012	2.81	1058	3.09
2855	529	0.88	612	1.12	685	1.37	751	1.62	812	1.88	869	2.15	922	2.41	972	2.69	1019	2.97	1065	3.25
2973	543	0.97	625	1.23	697	1.48	762	1.75	822	2.01	878	2.28	930	2.56	980	2.84	1027	3.13	1072	3.42
3091	558	1.07	638	1.33	708	1.60	772	1.87	831	2.15	887	2.43	939	2.71	988	3.00	1035	3.30	1080	3.60
3185	570	1.15	648	1.43	718	1.70	781	1.98	840	2.26	894	2.55	946	2.84	995	3.14	1041	3.44	1086	3.75

## FAN PERFORMANCE 50TC-D17 HORIZONTAL SI

L/s	Available External Static Pressure (Pa)																			
	50		100		150		200		250		300		350		400		450		500	
	RPM	kW	RPM	kW	RPM	kW	RPM	kW	RPM	kW	RPM	kW	RPM	kW	RPM	kW	RPM	kW	RPM	kW
1675	406	0.47	493	0.77	566	1.11	629	1.47	685	1.86	737	2.27	784	2.70	829	3.14	871	3.61	911	4.09
1793	421	0.54	506	0.85	577	1.20	640	1.57	696	1.97	747	2.40	794	2.84	839	3.30	881	3.77	920	4.27
1911	437	0.61	519	0.93	589	1.29	651	1.68	707	2.10	757	2.53	805	2.99	849	3.46	890	3.95	930	4.45
2029	453	0.69	532	1.02	601	1.40	662	1.80	717	2.23	768	2.68	815	3.14	859	3.63	900	4.13	940	4.65
2147	470	0.77	546	1.12	614	1.51	674	1.93	729	2.37	779	2.83	826	3.31	869	3.81	911	4.32	950	4.85
2265	487	0.87	561	1.23	627	1.63	686	2.06	740	2.51	790	2.99	836	3.48	880	3.99	921	4.52	—	—
2383	504	0.97	576	1.35	640	1.76	698	2.20	752	2.67	801	3.16	847	3.66	890	4.19	931	4.73	—	—
2501	522	1.09	591	1.47	654	1.90	711	2.35	764	2.83	813	3.33	858	3.85	901	4.39	—	—	—	—
2619	539	1.21	606	1.61	668	2.05	724	2.52	776	3.01	824	3.52	870	4.06	912	4.61	—	—	—	—
2737	558	1.35	622	1.76	682	2.21	737	2.69	789	3.19	836	3.72	881	4.27	—	—	—	—	—	—
2855	576	1.50	639	1.92	697	2.38	751	2.87	802	3.39	849	3.93	893	4.49	—	—	—	—	—	—
2973	594	1.65	655	2.09	712	2.56	765	3.07	815	3.60	861	4.15	905	4.72	—	—	—	—	—	—
3091	613	1.82	672	2.27	727	2.76	779	3.27	828	3.82	874	4.38	—	—	—	—	—	—	—	—
3185	628	1.97	685	2.42	740	2.92	791	3.45	839	4.00	884	4.58	—	—	—	—	—	—	—	—

**BOLD** Field Supplied Drive

— Not Applicable

Standard Static Drive

Medium Static Drive

High Static Drive

## FAN PERFORMANCE 50TC-D20 VERTICAL SI

L/s	Available External Static Pressure (Pa)																			
	50		100		150		200		250		300		350		400		450		500	
	RPM	kW	RPM	kW	RPM	kW	RPM	kW	RPM	kW	RPM	kW	RPM	kW	RPM	kW	RPM	kW	RPM	kW
1840	414	0.33	516	0.49	601	0.66	676	0.84	742	1.03	804	1.23	861	1.43	914	1.64	965	1.86	1012	2.09
1982	429	0.38	528	0.56	611	0.74	685	0.93	751	1.12	811	1.33	868	1.54	921	1.76	971	1.99	1019	2.22
2124	444	0.44	541	0.63	622	0.82	694	1.02	759	1.23	820	1.44	875	1.66	928	1.89	978	2.12	1025	2.36
2265	460	0.51	553	0.71	633	0.91	704	1.12	769	1.34	828	1.56	884	1.79	936	2.02	985	2.27	1032	2.52
2407	476	0.59	567	0.79	645	1.01	715	1.23	778	1.45	837	1.68	892	1.92	944	2.17	993	2.42	1039	2.68
2548	492	0.67	581	0.89	657	1.11	726	1.34	789	1.58	847	1.82	901	2.07	952	2.32	1001	2.58	1047	2.85
2690	509	0.76	595	0.99	670	1.23	737	1.47	799	1.71	857	1.96	910	2.22	961	2.49	1009	2.75	1055	3.03
2832	526	0.86	610	1.10	683	1.35	749	1.60	810	1.86	867	2.12	920	2.39	970	2.66	1018	2.94	1063	3.22
2973	543	0.97	625	1.23	697	1.48	762	1.75	822	2.01	878	2.28	930	2.56	980	2.84	1027	3.13	1072	3.42
3115	561	1.09	640	1.36	711	1.63	774	1.90	833	2.18	889	2.46	940	2.75	990	3.04	1036	3.33	1081	3.64
3256	579	1.22	656	1.50	725	1.78	788	2.06	846	2.35	900	2.64	951	2.94	1000	3.24	1046	3.55	1091	3.86
3398	597	1.36	672	1.65	739	1.94	801	2.24	858	2.54	912	2.84	962	3.15	1011	3.46	1056	3.78	1100	4.10
3539	615	1.51	688	1.81	754	2.12	815	2.42	871	2.73	924	3.05	974	3.37	1022	3.69	1067	4.02	1111	4.35

## FAN PERFORMANCE 50TC-D20 HORIZONTAL SI

L/s	Available External Static Pressure (Pa)																			
	50		100		150		200		250		300		350		400		450		500	
	RPM	kW	RPM	kW	RPM	kW	RPM	kW	RPM	kW	RPM	kW	RPM	kW	RPM	kW	RPM	kW	RPM	kW
1840	427	0.56	511	0.88	582	1.24	644	1.62	700	2.02	751	2.45	799	2.90	843	3.36	885	3.84	924	4.34
1982	446	0.65	527	0.99	596	1.36	658	1.75	713	2.18	764	2.62	811	3.08	855	3.56	896	4.06	936	4.57
2124	466	0.75	544	1.10	611	1.49	672	1.90	726	2.34	777	2.80	823	3.27	867	3.77	909	4.28	948	4.81
2265	487	0.87	561	1.23	627	1.63	686	2.06	740	2.51	790	2.99	836	3.48	880	3.99	921	4.52	—	—
2407	507	1.00	579	1.37	643	1.79	701	2.23	754	2.70	803	3.19	849	3.70	893	4.23	934	4.77	—	—
2548	529	1.14	597	1.53	659	1.96	716	2.42	769	2.90	817	3.41	863	3.93	906	4.48	—	—	—	—
2690	550	1.29	616	1.70	676	2.14	732	2.62	784	3.12	832	3.64	877	4.18	919	4.74	—	—	—	—
2832	572	1.46	635	1.89	694	2.34	748	2.83	799	3.35	846	3.89	891	4.44	—	—	—	—	—	—
2973	594	1.65	655	2.09	712	2.56	765	3.07	815	3.60	861	4.15	905	4.72	—	—	—	—	—	—
3115	617	1.86	675	2.31	730	2.80	782	3.32	831	3.86	877	4.43	—	—	—	—	—	—	—	—
3256	640	2.08	696	2.55	749	3.05	800	3.58	847	4.14	892	4.73	—	—	—	—	—	—	—	—
3398	662	2.33	717	2.80	768	3.32	818	3.87	864	4.44	—	—	—	—	—	—	—	—	—	—
3539	686	2.59	738	3.08	788	3.61	836	4.17	881	4.76	—	—	—	—	—	—	—	—	—	—

**BOLD** Field Supplied Drive

— Not Applicable

Standard Static Drive

Medium Static Drive

High Static Drive

## FAN PERFORMANCE 50TC-D24 VERTICAL SI

L/s	Available External Static Pressure (Pa)																			
	50		100		150		200		250		300		350		400		450		500	
	RPM	kW	RPM	kW	RPM	kW	RPM	kW	RPM	kW	RPM	kW	RPM	kW	RPM	kW	RPM	kW	RPM	kW
2147	447	0.45	543	0.64	624	0.83	696	1.04	761	1.24	821	1.46	877	1.68	929	1.91	979	2.15	1026	2.39
2312	465	0.53	558	0.74	637	0.94	708	1.15	772	1.37	831	1.60	886	1.83	938	2.07	987	2.32	1034	2.57
2478	484	0.63	574	0.84	651	1.06	720	1.28	783	1.51	842	1.75	896	1.99	948	2.24	997	2.50	1043	2.76
2643	503	0.73	590	0.96	666	1.19	734	1.42	796	1.67	853	1.92	907	2.17	958	2.43	1006	2.70	1052	2.97
2808	523	0.84	607	1.08	681	1.33	747	1.58	808	1.83	865	2.09	918	2.36	969	2.63	1016	2.91	1062	3.19
2973	543	0.97	625	1.23	697	1.48	762	1.75	822	2.01	878	2.28	930	2.56	980	2.84	1027	3.13	1072	3.42
3138	564	1.11	643	1.38	713	1.65	777	1.93	835	2.20	890	2.49	942	2.78	991	3.07	1038	3.37	1083	3.67
3303	585	1.26	661	1.55	730	1.83	792	2.12	850	2.41	904	2.71	955	3.01	1003	3.31	1050	3.62	1094	3.94
3469	606	1.43	680	1.73	747	2.03	808	2.33	865	2.63	918	2.94	968	3.26	1016	3.57	1062	3.89	1105	4.22
3634	628	1.62	699	1.93	764	2.24	824	2.56	880	2.87	932	3.19	982	3.52	1029	3.85	1074	4.18	1117	4.52
3799	650	1.82	719	2.14	782	2.47	841	2.80	896	3.13	947	3.46	996	3.80	1042	4.14	1087	4.49	1130	4.84
3964	671	2.04	739	2.38	801	2.72	858	3.06	912	3.40	962	3.75	1010	4.10	1056	4.45	1100	4.81	1143	5.17
4129	694	2.27	759	2.62	819	2.98	875	3.33	928	3.69	978	4.05	1025	4.41	1071	4.78	1114	5.15	1156	5.52

## FAN PERFORMANCE 50TC-D24 HORIZONTAL SI

L/s	Available External Static Pressure (Pa)																			
	50		100		150		200		250		300		350		400		450		500	
	RPM	kW	RPM	kW	RPM	kW	RPM	kW	RPM	kW	RPM	kW	RPM	kW	RPM	kW	RPM	kW	RPM	kW
2147	470	0.77	546	1.12	614	1.51	674	1.93	729	2.37	779	2.83	826	3.31	869	3.81	911	4.32	950	4.85
2312	493	0.91	567	1.28	632	1.68	691	2.12	745	2.57	794	3.05	841	3.55	884	4.07	925	4.60	964	5.15
2478	518	1.06	588	1.45	651	1.87	709	2.32	761	2.80	810	3.30	856	3.82	899	4.35	940	4.90	979	5.47
2643	543	1.24	610	1.64	671	2.08	727	2.55	779	3.04	827	3.56	872	4.10	915	4.65	955	5.22	994	5.80
2808	568	1.43	632	1.85	691	2.31	746	2.80	796	3.31	844	3.84	888	4.40	931	4.97	971	5.56	1009	6.16
2973	594	1.65	655	2.09	712	2.56	765	3.07	815	3.60	861	4.15	905	4.72	947	5.31	986	5.92	1024	6.54
3138	621	1.90	679	2.35	734	2.84	785	3.36	833	3.91	879	4.48	922	5.07	964	5.68	1003	6.30	1040	6.94
3303	647	2.16	703	2.63	756	3.14	806	3.68	853	4.24	898	4.83	940	5.44	981	6.06	1019	6.71	1057	7.37
3469	674	2.45	727	2.94	778	3.46	827	4.02	873	4.60	917	5.21	958	5.83	998	6.48	1036	7.14	1073	7.82
3634	701	2.78	752	3.28	801	3.82	848	4.39	893	4.99	936	5.61	977	6.26	1016	6.92	1054	7.60	1090	8.30
3799	728	3.13	777	3.65	825	4.20	870	4.79	914	5.41	956	6.05	996	6.71	1035	7.39	1072	8.09	1108	8.80
3964	756	3.51	803	4.04	849	4.62	893	5.22	935	5.85	976	6.51	1016	7.19	1054	7.89	1090	8.60	—	—
4129	783	3.92	829	4.47	873	5.06	916	5.68	957	6.33	997	7.01	1036	7.70	1073	8.42	—	—	—	—

**BOLD** Field Supplied Drive

— Not Applicable

Standard Static Drive

Medium Static Drive

High Static Drive

## FAN PERFORMANCE 50TC-D28 VERTICAL SI

L/s	Available External Static Pressure (Pa)																			
	50		100		150		200		250		300		350		400		450		500	
	RPM	kW	RPM	kW	RPM	kW	RPM	kW	RPM	kW	RPM	kW	RPM	kW	RPM	kW	RPM	kW	RPM	kW
2832	506	0.65	603	0.90	684	1.14	755	1.40	819	1.66	878	1.93	932	2.20	983	2.48	1032	2.76	1078	3.05
3020	526	0.75	620	1.01	700	1.28	770	1.55	833	1.82	891	2.10	945	2.39	996	2.68	1044	2.98	1090	3.28
3209	545	0.86	638	1.14	716	1.43	785	1.71	848	2.00	905	2.29	959	2.59	1009	2.89	1057	3.20	1102	3.52
3398	566	0.99	656	1.29	733	1.58	801	1.88	863	2.18	920	2.49	973	2.80	1023	3.12	1070	3.44	1115	3.77
3587	586	1.13	674	1.44	750	1.76	817	2.07	878	2.39	934	2.71	987	3.03	1037	3.37	1084	3.70	1128	4.04
3775	607	1.28	693	1.61	767	1.94	833	2.27	893	2.60	949	2.94	1001	3.28	1051	3.62	1097	3.97	1142	4.33
3964	628	1.44	712	1.79	784	2.14	850	2.49	909	2.83	964	3.18	1016	3.54	1065	3.90	1111	4.26	1155	4.63
4153	650	1.62	731	1.99	802	2.35	866	2.72	925	3.08	980	3.45	1031	3.81	1080	4.19	1126	4.56	1169	4.94
4342	671	1.82	751	2.20	821	2.58	884	2.96	942	3.34	996	3.72	1047	4.11	1095	4.49	1140	4.89	1184	5.28
4530	693	2.03	771	2.43	839	2.83	901	3.23	959	3.62	1012	4.02	1062	4.42	1110	4.82	1155	5.22	1198	5.63
4719	715	2.26	791	2.68	858	3.09	919	3.51	976	3.92	1028	4.33	1078	4.74	1125	5.16	1170	5.58	1213	6.00

## FAN PERFORMANCE 50TC-D28 HORIZONTAL SI

L/s	Available External Static Pressure (Pa)																			
	50		100		150		200		250		300		350		400		450		500	
	RPM	kW	RPM	kW	RPM	kW	RPM	kW	RPM	kW	RPM	kW	RPM	kW	RPM	kW	RPM	kW	RPM	kW
2832	572	1.46	635	1.89	694	2.34	748	2.83	799	3.35	846	3.89	891	4.44	933	5.02	973	5.61	1011	6.21
3020	602	1.72	662	2.16	718	2.64	771	3.15	820	3.68	866	4.24	910	4.82	952	5.41	991	6.02	1029	6.65
3209	632	2.01	689	2.47	743	2.96	794	3.49	842	4.05	887	4.62	930	5.22	971	5.84	1010	6.47	1047	7.12
3398	662	2.33	717	2.80	768	3.32	818	3.87	864	4.44	908	5.04	951	5.66	991	6.30	1029	6.95	1066	7.62
3587	693	2.68	745	3.18	795	3.71	842	4.28	887	4.88	930	5.49	972	6.13	1011	6.79	1049	7.47	1085	8.16
3775	724	3.07	774	3.59	821	4.15	867	4.73	911	5.35	953	5.98	993	6.64	1032	7.32	1069	8.02	—	—
3964	756	3.51	803	4.04	849	4.62	893	5.22	935	5.85	976	6.51	1016	7.19	1054	7.89	—	—	—	—
4153	787	3.98	832	4.53	876	5.13	919	5.75	960	6.40	1000	7.08	1039	7.78	—	—	—	—	—	—
4342	819	4.49	862	5.07	905	5.68	946	6.33	986	7.00	1025	7.69	—	—	—	—	—	—	—	—
4530	851	5.05	892	5.65	933	6.28	973	6.94	1012	7.64	—	—	—	—	—	—	—	—	—	—
4719	883	5.66	923	6.28	962	6.93	1001	7.61	—	—	—	—	—	—	—	—	—	—	—	—

**BOLD** Field Supplied Drive

— Not Applicable

Standard Static Drive

Medium Static Drive

High Static Drive

## FAN PERFORMANCE 50TC-D30 VERTICAL SI

L/s	Available External Static Pressure (Pa)																			
	50		100		150		200		250		300		350		400		450		500	
	RPM	kW	RPM	kW	RPM	kW	RPM	kW	RPM	kW	RPM	kW	RPM	kW	RPM	kW	RPM	kW	RPM	kW
<b>3539</b>	581	1.09	669	1.40	745	1.71	813	2.02	874	2.34	931	2.65	983	2.98	1033	3.30	1080	3.64	1125	3.97
<b>3775</b>	607	1.28	693	1.61	767	1.94	833	2.27	893	2.60	949	2.94	1001	3.28	1051	3.62	1097	3.97	1142	4.33
<b>4011</b>	634	1.49	717	1.84	789	2.19	854	2.54	913	2.89	968	3.25	1020	3.61	1069	3.97	1115	4.33	<b>1159</b>	<b>4.70</b>
<b>4247</b>	660	1.72	741	2.10	811	2.47	875	2.84	933	3.21	988	3.58	1039	3.96	1087	4.34	1133	4.72	<b>1177</b>	<b>5.11</b>
<b>4483</b>	688	1.98	766	2.38	834	2.77	897	3.16	954	3.55	1008	3.94	1058	4.34	1106	4.74	1151	5.14	<b>1195</b>	<b>5.54</b>
<b>4719</b>	715	2.26	791	2.68	858	3.09	919	3.51	976	3.92	1028	4.33	1078	4.74	1125	5.16	<b>1170</b>	<b>5.58</b>	—	—
<b>4955</b>	743	2.57	816	3.01	882	3.45	942	3.88	997	4.31	1049	4.75	1098	5.18	1145	5.62	—	—	—	—
<b>5191</b>	771	2.91	842	3.37	906	3.83	965	4.29	1020	4.74	1071	5.19	1119	5.65	<b>1165</b>	<b>6.10</b>	—	—	—	—
<b>5427</b>	799	3.28	868	3.77	931	4.25	988	4.72	1042	5.20	1093	5.67	1140	6.14	—	—	—	—	—	—
<b>5663</b>	828	3.68	895	4.19	956	4.69	1012	5.19	1065	5.68	1115	6.18	—	—	—	—	—	—	—	—
<b>5899</b>	856	4.11	922	4.64	981	5.17	1037	5.69	1088	6.21	1137	6.72	—	—	—	—	—	—	—	—

## FAN PERFORMANCE 50TC-D30 HORIZONTAL SI

L/s	Available External Static Pressure (Pa)																			
	50		100		150		200		250		300		350		400		450		500	
	RPM	kW	RPM	kW	RPM	kW	RPM	kW	RPM	kW	RPM	kW	RPM	kW	RPM	kW	RPM	kW	RPM	kW
<b>3539</b>	655	1.90	711	2.36	765	2.87	817	3.42	866	4.01	913	4.64	958	5.29	1001	5.96	1042	6.66	1081	7.38
<b>3775</b>	691	2.24	744	2.72	795	3.25	845	3.82	893	4.43	938	5.07	982	5.74	1024	6.44	1064	7.16	1102	7.90
<b>4011</b>	728	2.63	777	3.13	826	3.67	874	4.26	920	4.89	964	5.55	1006	6.24	1047	6.96	1086	7.70	1124	8.46
<b>4247</b>	765	3.06	812	3.58	858	4.15	904	4.75	948	5.40	990	6.08	1032	6.79	1071	7.53	1110	8.29	—	—
<b>4483</b>	802	3.54	847	4.08	891	4.67	934	5.29	977	5.96	1018	6.66	1058	7.38	1097	8.14	—	—	—	—
<b>4719</b>	840	4.08	882	4.63	924	5.24	966	5.88	1007	6.57	1046	7.28	1085	#	—	—	—	—	—	—
<b>4955</b>	878	4.66	918	5.24	958	5.86	998	6.53	1037	7.23	1075	7.96	—	—	—	—	—	—	—	—
<b>5191</b>	916	5.30	954	5.90	992	6.54	1031	7.23	1068	7.95	—	—	—	—	—	—	—	—	—	—
<b>5427</b>	954	6.00	991	6.63	1027	7.29	1064	7.99	1100	8.73	—	—	—	—	—	—	—	—	—	—
<b>5663</b>	992	6.77	1027	7.41	1063	8.09	—	—	—	—	—	—	—	—	—	—	—	—	—	—
<b>5899</b>	1031	7.59	1064	8.26	—	—	—	—	—	—	—	—	—	—	—	—	—	—	—	—

**BOLD** Field Supplied Drive

— Not Applicable

Standard Static Drive

Medium Static Drive

High Static Drive

## FAN PERFORMANCE 50TC-D17 VERTICAL ENGLISH

CFM	Available External Static Pressure (in. wg)																			
	0.2		0.4		0.6		0.8		1.0		1.2		1.4		1.6		1.8		2.0	
	RPM	BHP	RPM	BHP	RPM	BHP	RPM	BHP	RPM	BHP	RPM	BHP	RPM	BHP	RPM	BHP	RPM	BHP	RPM	BHP
3550	398	0.37	504	0.57	590	0.78	666	1.01	733	1.25	795	1.50	853	1.76	907	2.03	958	2.31	1006	2.60
3800	410	0.42	513	0.63	598	0.86	673	1.09	740	1.34	801	1.60	858	1.87	912	2.15	962	2.44	1011	2.74
4050	422	0.47	522	0.70	606	0.94	680	1.18	747	1.44	808	1.71	864	1.99	917	2.28	968	2.58	1015	2.89
4300	434	0.54	532	0.78	615	1.02	688	1.28	754	1.55	814	1.83	870	2.12	923	2.42	973	2.72	1021	3.04
4550	447	0.61	543	0.86	624	1.12	696	1.39	761	1.67	821	1.96	877	2.25	929	2.56	979	2.88	1026	3.20
4800	460	0.68	553	0.95	633	1.22	704	1.50	769	1.79	828	2.09	884	2.40	936	2.71	985	3.04	1032	3.37
5050	473	0.77	565	1.04	643	1.33	713	1.62	777	1.92	836	2.23	891	2.55	942	2.87	991	3.21	1038	3.55
5300	487	0.86	576	1.15	653	1.44	722	1.75	785	2.06	843	2.38	898	2.71	949	3.04	998	3.39	1044	3.74
5550	500	0.96	588	1.26	664	1.57	732	1.88	794	2.20	851	2.53	906	2.87	956	3.22	1005	3.57	1051	3.94
5800	515	1.06	600	1.38	674	1.70	741	2.03	803	2.36	860	2.70	913	3.05	964	3.41	1012	3.77	1058	4.14
6050	529	1.18	612	1.51	685	1.84	751	2.18	812	2.52	869	2.88	922	3.24	972	3.60	1019	3.98	1065	4.36
6300	543	1.30	625	1.64	697	1.99	762	2.34	822	2.70	878	3.06	930	3.43	980	3.81	1027	4.20	1072	4.59
6550	558	1.43	638	1.79	708	2.15	772	2.51	831	2.88	887	3.26	939	3.64	988	4.03	1035	4.42	1080	4.83
6750	570	1.55	648	1.91	718	2.28	781	2.65	840	3.03	894	3.42	946	3.81	995	4.21	1041	4.61	1086	5.02

## FAN PERFORMANCE 50TC-D17 HORIZONTAL ENGLISH

CFM	Available External Static Pressure (in. wg)																			
	0.2		0.4		0.6		0.8		1.0		1.2		1.4		1.6		1.8		2.0	
	RPM	BHP	RPM	BHP	RPM	BHP	RPM	BHP	RPM	BHP	RPM	BHP	RPM	BHP	RPM	BHP	RPM	BHP	RPM	BHP
3550	406	0.63	493	1.04	566	1.49	629	1.97	685	2.49	737	3.04	784	3.61	829	4.21	871	4.83	911	5.48
3800	421	0.72	506	1.14	577	1.61	640	2.11	696	2.65	747	3.21	794	3.80	839	4.42	881	5.06	920	5.72
4050	437	0.81	519	1.25	589	1.74	651	2.26	707	2.81	757	3.39	805	4.00	849	4.64	890	5.29	930	5.97
4300	453	0.92	532	1.37	601	1.87	662	2.41	717	2.99	768	3.59	815	4.21	859	4.86	900	5.54	940	6.23
4550	470	1.04	546	1.50	614	2.02	674	2.58	729	3.17	779	3.79	826	4.43	869	5.10	911	5.79	950	6.50
4800	487	1.16	561	1.65	627	2.19	686	2.76	740	3.37	790	4.00	836	4.67	880	5.35	921	6.06	—	—
5050	504	1.30	576	1.81	640	2.36	698	2.95	752	3.58	801	4.23	847	4.91	890	5.61	931	6.34	—	—
5300	522	1.46	591	1.98	654	2.55	711	3.16	764	3.80	813	4.47	858	5.17	901	5.89	—	—	—	—
5550	539	1.63	606	2.16	668	2.75	724	3.37	776	4.03	824	4.72	870	5.44	912	6.17	—	—	—	—
5800	558	1.81	622	2.36	682	2.96	737	3.60	789	4.28	836	4.99	881	5.72	—	—	—	—	—	—
6050	576	2.00	639	2.57	697	3.19	751	3.85	802	4.54	849	5.27	893	6.02	—	—	—	—	—	—
6300	594	2.22	655	2.80	712	3.43	765	4.11	815	4.82	861	5.56	905	6.33	—	—	—	—	—	—
6550	613	2.44	672	3.04	727	3.69	779	4.39	828	5.11	874	5.87	—	—	—	—	—	—	—	—
6750	628	2.64	685	3.25	740	3.91	791	4.62	839	5.36	884	6.13	—	—	—	—	—	—	—	—

**BOLD** Field Supplied Drive

— Not Applicable

Standard Static Drive

Medium Static Drive

High Static Drive

## FAN PERFORMANCE 50TC-D20 VERTICAL ENGLISH

CFM	Available External Static Pressure (in. wg)																			
	0.2		0.4		0.6		0.8		1.0		1.2		1.4		1.6		1.8		2.0	
	RPM	BHP	RPM	BHP	RPM	BHP	RPM	BHP	RPM	BHP	RPM	BHP	RPM	BHP	RPM	BHP	RPM	BHP	RPM	BHP
3900	414	0.44	516	0.66	601	0.89	676	1.13	742	1.38	804	1.65	861	1.92	914	2.20	965	2.50	1012	2.80
4200	429	0.51	528	0.75	611	0.99	685	1.24	751	1.51	811	1.78	868	2.07	921	2.36	971	2.66	1019	2.98
4500	444	0.59	541	0.84	622	1.10	694	1.37	759	1.64	820	1.93	875	2.23	928	2.53	978	2.85	1025	3.17
4800	460	0.68	553	0.95	633	1.22	704	1.50	769	1.79	828	2.09	884	2.40	936	2.71	985	3.04	1032	3.37
5100	476	0.79	567	1.06	645	1.35	715	1.64	778	1.95	837	2.26	892	2.58	944	2.91	993	3.24	1039	3.59
5400	492	0.90	581	1.19	657	1.49	726	1.80	789	2.12	847	2.44	901	2.77	952	3.11	1001	3.46	1047	3.82
5700	509	1.02	595	1.33	670	1.65	737	1.97	799	2.30	857	2.63	910	2.98	961	3.33	1009	3.69	1055	4.06
6000	526	1.15	610	1.48	683	1.81	749	2.15	810	2.49	867	2.84	920	3.20	970	3.56	1018	3.94	1063	4.32
6300	543	1.30	625	1.64	697	1.99	762	2.34	822	2.70	878	3.06	930	3.43	980	3.81	1027	4.20	1072	4.59
6600	561	1.46	640	1.82	711	2.18	774	2.55	833	2.92	889	3.29	940	3.68	990	4.07	1036	4.47	1081	4.87
6900	579	1.63	656	2.01	725	2.38	788	2.77	846	3.15	900	3.54	951	3.94	1000	4.35	1046	4.76	1091	5.18
7200	597	1.82	672	2.21	739	2.60	801	3.00	858	3.40	912	3.81	962	4.22	1011	4.64	1056	5.06	1100	5.49
7500	615	2.02	688	2.43	754	2.84	815	3.25	871	3.67	924	4.09	974	4.51	1022	4.94	1067	5.38	1111	5.83

## FAN PERFORMANCE 50TC-D20 HORIZONTAL ENGLISH

CFM	Available External Static Pressure (in. wg)																			
	0.2		0.4		0.6		0.8		1.0		1.2		1.4		1.6		1.8		2.0	
	RPM	BHP	RPM	BHP	RPM	BHP	RPM	BHP	RPM	BHP	RPM	BHP	RPM	BHP	RPM	BHP	RPM	BHP	RPM	BHP
3900	427	0.75	511	1.18	582	1.66	644	2.17	700	2.71	751	3.28	799	3.88	843	4.50	885	5.15	924	5.82
4200	446	0.87	527	1.32	596	1.82	658	2.35	713	2.92	764	3.51	811	4.13	855	4.77	896	5.44	936	6.12
4500	466	1.01	544	1.48	611	1.99	672	2.55	726	3.13	777	3.75	823	4.39	867	5.05	909	5.74	948	6.45
4800	487	1.16	561	1.65	627	2.19	686	2.76	740	3.37	790	4.00	836	4.66	880	5.35	921	6.06	—	—
5100	507	1.33	579	1.84	643	2.40	701	2.99	754	3.62	803	4.28	849	4.96	893	5.67	934	6.40	—	—
5400	529	1.52	597	2.05	659	2.63	716	3.24	769	3.89	817	4.57	863	5.27	906	6.00	—	—	—	—
5700	550	1.73	616	2.28	676	2.87	732	3.51	784	4.18	832	4.88	877	5.60	919	6.35	—	—	—	—
6000	572	1.96	635	2.53	694	3.14	748	3.80	799	4.49	846	5.21	891	5.96	—	—	—	—	—	—
6300	594	2.22	655	2.80	712	3.43	765	4.11	815	4.82	861	5.56	905	6.33	—	—	—	—	—	—
6600	617	2.49	675	3.09	730	3.75	782	4.44	831	5.17	877	5.94	—	—	—	—	—	—	—	—
6900	640	2.79	696	3.41	749	4.09	800	4.80	847	5.55	892	6.34	—	—	—	—	—	—	—	—
7200	662	3.12	717	3.76	768	4.45	818	5.19	864	5.96	—	—	—	—	—	—	—	—	—	—
7500	686	3.47	738	4.13	788	4.84	836	5.60	881	6.39	—	—	—	—	—	—	—	—	—	—

**BOLD** Field Supplied Drive

— Not Applicable

Standard Static Drive

Medium Static Drive

High Static Drive



## FAN PERFORMANCE 50TC-D24 VERTICAL ENGLISH

CFM	Available External Static Pressure (in. wg)																			
	0.2		0.4		0.6		0.8		1.0		1.2		1.4		1.6		1.8		2.0	
	RPM	BHP	RPM	BHP	RPM	BHP	RPM	BHP	RPM	BHP	RPM	BHP	RPM	BHP	RPM	BHP	RPM	BHP	RPM	BHP
4550	447	0.61	543	0.86	624	1.12	696	1.39	761	1.67	821	1.96	877	2.25	929	2.56	979	2.88	1026	3.20
4900	465	0.72	558	0.99	637	1.26	708	1.55	772	1.84	831	2.14	886	2.46	938	2.78	987	3.11	1034	3.44
5250	484	0.84	574	1.13	651	1.42	720	1.72	783	2.03	842	2.35	896	2.67	948	3.01	997	3.35	1043	3.70
5600	503	0.98	590	1.28	666	1.59	734	1.91	796	2.23	853	2.57	907	2.91	958	3.26	1006	3.61	1052	3.98
5950	523	1.13	607	1.45	681	1.78	747	2.12	808	2.46	865	2.81	918	3.16	969	3.52	1016	3.90	1062	4.27
6300	543	1.30	625	1.64	697	1.99	762	2.34	822	2.70	878	3.06	930	3.43	980	3.81	1027	4.20	1072	4.59
6650	564	1.49	643	1.85	713	2.21	777	2.58	835	2.95	890	3.34	942	3.72	991	4.12	1038	4.52	1083	4.92
7000	585	1.69	661	2.07	730	2.46	792	2.84	850	3.23	904	3.63	955	4.03	1003	4.44	1050	4.86	1094	5.28
7350	606	1.92	680	2.32	747	2.72	808	3.12	865	3.53	918	3.95	968	4.36	1016	4.79	1062	5.22	1105	5.66
7700	628	2.17	699	2.59	764	3.00	824	3.43	880	3.85	932	4.28	982	4.72	1029	5.16	1074	5.61	1117	6.06
8050	650	2.44	719	2.87	782	3.31	841	3.75	896	4.19	947	4.64	996	5.09	1042	5.55	1087	6.01	1130	6.48
8400	671	2.73	739	3.18	801	3.64	858	4.10	912	4.56	962	5.02	1010	5.49	1056	5.97	1100	6.45	1143	6.93
8750	694	3.04	759	3.52	819	3.99	875	4.47	928	4.95	978	5.43	1025	5.92	1071	6.41	1114	6.90	1156	7.40

## FAN PERFORMANCE 50TC-D24 HORIZONTAL ENGLISH

CFM	Available External Static Pressure (in. wg)																			
	0.2		0.4		0.6		0.8		1.0		1.2		1.4		1.6		1.8		2.0	
	RPM	BHP	RPM	BHP	RPM	BHP	RPM	BHP	RPM	BHP	RPM	BHP	RPM	BHP	RPM	BHP	RPM	BHP	RPM	BHP
4550	470	1.04	546	1.50	614	2.02	674	2.58	729	3.17	779	3.79	826	4.43	869	5.10	911	5.79	950	6.50
4900	493	1.22	567	1.71	632	2.25	691	2.84	745	3.45	794	4.09	841	4.76	884	5.45	925	6.17	964	6.91
5250	518	1.43	588	1.94	651	2.51	709	3.11	761	3.75	810	4.42	856	5.11	899	5.83	940	6.57	979	7.33
5600	543	1.66	610	2.20	671	2.79	727	3.42	779	4.08	827	4.77	872	5.49	915	6.23	955	7.00	994	7.78
5950	568	1.92	632	2.48	691	3.10	746	3.75	796	4.44	844	5.15	888	5.89	931	6.66	971	7.45	1009	8.26
6300	594	2.22	655	2.80	712	3.43	765	4.11	815	4.82	861	5.56	905	6.33	947	7.12	986	7.93	1024	8.77
6650	621	2.54	679	3.15	734	3.80	785	4.50	833	5.24	879	6.00	922	6.79	964	7.61	1003	8.45	1040	9.31
7000	647	2.90	703	3.53	756	4.21	806	4.93	853	5.68	898	6.47	940	7.29	981	8.13	1019	8.99	1057	9.88
7350	674	3.29	727	3.94	778	4.64	827	5.39	873	6.17	917	6.98	958	7.82	998	8.68	1036	9.57	1073	10.48
7700	701	3.72	752	4.39	801	5.12	848	5.89	893	6.69	936	7.52	977	8.39	1016	9.27	1054	10.19	1090	11.12
8050	728	4.19	777	4.89	825	5.63	870	6.42	914	7.25	956	8.11	996	8.99	1035	9.91	1072	10.84	1108	11.80
8400	756	4.70	803	5.42	849	6.19	893	7.00	935	7.85	976	8.73	1016	9.64	1054	10.57	1090	11.53	—	—
8750	783	5.25	829	5.99	873	6.78	916	7.62	957	8.49	997	9.39	1036	10.33	1073	11.29	—	—	—	—

**BOLD** Field Supplied Drive

— Not Applicable

Standard Static Drive

Medium Static Drive

High Static Drive

## FAN PERFORMANCE 50TC-D28 VERTICAL ENGLISH

CFM	Available External Static Pressure (in. wg)																			
	0.2		0.4		0.6		0.8		1.0		1.2		1.4		1.6		1.8		2.0	
	RPM	BHP	RPM	BHP	RPM	BHP	RPM	BHP	RPM	BHP	RPM	BHP	RPM	BHP	RPM	BHP	RPM	BHP	RPM	BHP
6000	506	0.87	603	1.20	684	1.53	755	1.88	819	2.22	878	2.58	932	2.95	983	3.32	1032	3.70	1078	4.09
6400	526	1.01	620	1.36	700	1.71	770	2.08	833	2.44	891	2.82	945	3.20	996	3.59	1044	3.99	1090	4.40
6800	545	1.16	638	1.53	716	1.91	785	2.29	848	2.68	905	3.07	959	3.47	1009	3.88	1057	4.29	1102	4.72
7200	566	1.33	656	1.73	733	2.12	801	2.52	863	2.93	920	3.34	973	3.76	1023	4.18	1070	4.62	1115	5.06
7600	586	1.51	674	1.93	750	2.35	817	2.77	878	3.20	934	3.63	987	4.07	1037	4.51	1084	4.96	1128	5.42
8000	607	1.71	693	2.16	767	2.60	833	3.04	893	3.49	949	3.94	1001	4.40	1051	4.86	1097	5.32	1142	5.80
8400	628	1.94	712	2.40	784	2.87	850	3.33	909	3.80	964	4.27	1016	4.74	1065	5.22	1111	5.71	1155	6.20
8800	650	2.18	731	2.67	802	3.16	866	3.64	925	4.13	980	4.62	1031	5.11	1080	5.61	1126	6.12	1169	6.63
9200	671	2.44	751	2.96	821	3.46	884	3.97	942	4.48	996	4.99	1047	5.51	1095	6.03	1140	6.55	1184	7.08
9600	693	2.72	771	3.26	839	3.80	901	4.32	959	4.85	1012	5.39	1062	5.92	1110	6.46	1155	7.00	1198	7.55
10000	715	3.03	791	3.59	858	4.15	919	4.70	976	5.25	1028	5.80	1078	6.36	1125	6.92	1170	7.48	1213	8.05

## FAN PERFORMANCE 50TC-D28 HORIZONTAL ENGLISH

CFM	Available External Static Pressure (in. wg)																			
	0.2		0.4		0.6		0.8		1.0		1.2		1.4		1.6		1.8		2.0	
	RPM	BHP	RPM	BHP	RPM	BHP	RPM	BHP	RPM	BHP	RPM	BHP	RPM	BHP	RPM	BHP	RPM	BHP	RPM	BHP
6000	572	1.96	635	2.53	694	3.14	748	3.80	799	4.49	846	5.21	891	5.96	933	6.73	973	7.52	1011	8.33
6400	602	2.31	662	2.89	718	3.54	771	4.22	820	4.94	866	5.68	910	6.46	952	7.26	991	8.08	1029	8.92
6800	632	2.69	689	3.30	743	3.97	794	4.68	842	5.42	887	6.20	930	7.00	971	7.83	1010	8.68	1047	9.55
7200	662	3.12	717	3.76	768	4.45	818	5.19	864	5.96	908	6.76	951	7.59	991	8.44	1029	9.32	1066	10.22
7600	693	3.59	745	4.26	795	4.98	842	5.74	887	6.54	930	7.37	972	8.22	1011	9.10	1049	10.01	1085	10.93
8000	724	4.12	774	4.81	821	5.56	867	6.34	911	7.17	953	8.02	993	8.91	1032	9.81	1069	10.74	—	—
8400	756	4.70	803	5.42	849	6.19	893	7.00	935	7.85	976	8.73	1016	9.64	1054	10.57	—	—	—	—
8800	787	5.33	832	6.08	876	6.87	919	7.71	960	8.58	1000	9.49	1039	10.43	—	—	—	—	—	—
9200	819	6.02	862	6.79	905	7.62	946	8.48	986	9.38	1025	10.31	—	—	—	—	—	—	—	—
9600	851	6.77	892	7.57	933	8.42	973	9.31	1012	10.23	—	—	—	—	—	—	—	—	—	—
10000	883	7.59	923	8.41	962	9.29	1001	10.20	—	—	—	—	—	—	—	—	—	—	—	—

**BOLD** Field Supplied Drive

— Not Applicable

Standard Static Drive

Medium Static Drive

High Static Drive

## FAN PERFORMANCE 50TC-D30 VERTICAL ENGLISH

CFM	Available External Static Pressure (in. wg)																			
	0.2		0.4		0.6		0.8		1.0		1.2		1.4		1.6		1.8		2.0	
	RPM	BHP	RPM	BHP	RPM	BHP	RPM	BHP	RPM	BHP	RPM	BHP	RPM	BHP	RPM	BHP	RPM	BHP	RPM	BHP
7500	581	1.46	669	1.88	745	2.29	813	2.71	874	3.13	931	3.56	983	3.99	1033	4.43	1080	4.87	1125	5.33
8000	607	1.71	693	2.16	767	2.60	833	3.04	893	3.49	949	3.94	1001	4.40	1051	4.86	1097	5.32	1142	5.80
8500	634	1.99	717	2.47	789	2.94	854	3.41	913	3.88	968	4.35	1020	4.83	1069	5.32	1115	5.81	1159	6.31
9000	660	2.31	741	2.81	811	3.31	875	3.80	933	4.30	988	4.80	1039	5.31	1087	5.82	1133	6.33	1177	6.85
9500	688	2.65	766	3.18	834	3.71	897	4.23	954	4.76	1008	5.29	1058	5.81	1106	6.35	1151	6.89	1195	7.43
10000	715	3.03	791	3.59	858	4.15	919	4.70	976	5.25	1028	5.80	1078	6.36	1125	6.92	1170	7.48	—	—
10500	743	3.44	816	4.04	882	4.62	942	5.20	997	5.78	1049	6.36	1098	6.94	1145	7.53	—	—	—	—
11000	771	3.90	842	4.52	906	5.14	965	5.75	1020	6.35	1071	6.96	1119	7.57	1165	8.18	—	—	—	—
11500	799	4.39	868	5.05	931	5.69	988	6.33	1042	6.96	1093	7.60	1140	8.23	—	—	—	—	—	—
12000	828	4.93	895	5.62	956	6.29	1012	6.96	1065	7.62	1115	8.28	—	—	—	—	—	—	—	—
12500	856	5.51	922	6.23	981	6.93	1037	7.63	1088	8.32	1137	9.01	—	—	—	—	—	—	—	—

## FAN PERFORMANCE 50TC-D30 HORIZONTAL ENGLISH

CFM	Available External Static Pressure (in. wg)																			
	0.2		0.4		0.6		0.8		1.0		1.2		1.4		1.6		1.8		2.0	
	RPM	BHP	RPM	BHP	RPM	BHP	RPM	BHP	RPM	BHP	RPM	BHP	RPM	BHP	RPM	BHP	RPM	BHP	RPM	BHP
7500	655	2.55	711	3.16	765	3.85	817	4.59	866	5.38	913	6.21	958	7.08	1001	7.99	1042	8.92	1081	9.89
8000	691	3.01	744	3.65	795	4.36	845	5.12	893	5.94	938	6.80	982	7.70	1024	8.63	1064	9.60	1102	10.59
8500	728	3.53	777	4.19	826	4.93	874	5.72	920	6.56	964	7.45	1006	8.37	1047	9.33	1086	10.32	1124	11.34
9000	765	4.11	812	4.80	858	5.56	904	6.37	948	7.24	990	8.15	1032	9.10	1071	10.09	1110	11.11	—	—
9500	802	4.75	847	5.47	891	6.26	934	7.09	977	7.99	1018	8.92	1058	9.90	1097	10.91	—	—	—	—
10000	840	5.47	882	6.21	924	7.02	966	7.88	1007	8.80	1046	9.76	1085	10.76	—	—	—	—	—	—
10500	878	6.25	918	7.02	958	7.86	998	8.75	1037	9.69	1075	10.67	—	—	—	—	—	—	—	—
11000	916	7.11	954	7.91	992	8.77	1031	9.69	1068	10.65	—	—	—	—	—	—	—	—	—	—
11500	954	8.05	991	8.88	1027	9.77	1064	10.71	1100	11.70	—	—	—	—	—	—	—	—	—	—
12000	992	9.07	1027	9.93	1063	10.85	—	—	—	—	—	—	—	—	—	—	—	—	—	—
12500	1031	10.18	1064	11.07	—	—	—	—	—	—	—	—	—	—	—	—	—	—	—	—

**BOLD** Field Supplied Drive

— Not Applicable

Standard Static Drive

Medium Static Drive

High Static Drive

## PULLEY ADJUSTMENT — VERTICAL

UNIT	MOTOR/DRIVE COMBO	MOTORPULLEYTURNSOPEN											
		0.0	0.5	1.0	1.5	2.0	2.5	3.0	3.5	4.0	4.5	5.0	
17	3 phase	Standard Static	588	576	563	551	538	526	513	501	488	476	463
		Medium Static	713	698	683	667	652	637	622	607	591	576	561
		High Static	887	871	855	839	823	807	790	774	758	742	726
20	3 phase	Standard Static	644	630	617	603	589	576	562	548	534	521	507
		Medium Static	803	788	773	758	743	728	712	697	682	667	652
		High Static	1001	981	961	941	921	901	881	861	841	821	801
24	3 phase	Standard Static	692	679	667	654	642	629	616	604	591	579	566
		Medium Static	840	825	809	794	779	764	748	733	718	702	687
		High Static	1008	990	971	953	934	916	898	879	861	842	824
28	3 phase	Standard Static	809	794	778	763	748	733	717	702	687	671	656
		Medium Static	918	901	885	868	851	835	818	801	784	768	751
		High Static	1064	1045	1025	1006	987	968	948	929	910	890	871
30	3 phase	Standard Static	784	767	751	734	717	701	684	667	650	634	617
		Medium Static	916	898	879	861	843	825	806	788	770	751	733
		High Static	1151	1128	1104	1081	1058	1035	1011	988	965	941	918

NOTE: Do not adjust pulley further than 5 turns open.

Factory settings

## PULLEY ADJUSTMENT — HORIZONTAL

UNIT	MOTOR/DRIVE COMBO	MOTORPULLEYTURNSOPEN											
		0.0	0.5	1.0	1.5	2.0	2.5	3.0	3.5	4.0	4.5	5.0	
17	3 phase	Standard Static	588	576	563	551	538	526	513	501	488	476	463
		Medium Static	713	698	683	667	652	637	622	607	591	576	561
		High Static	887	871	855	839	823	807	790	774	758	742	726
20	3 phase	Standard Static	644	630	617	603	589	576	562	548	534	521	507
		Medium Static	803	788	773	758	743	728	712	697	682	667	652
		High Static	1001	981	961	941	921	901	881	861	841	821	801
24	3 phase	Standard Static	692	679	667	654	642	629	616	604	591	579	566
		Medium Static	840	825	809	794	779	764	748	733	718	702	687
		High Static	1008	990	971	953	934	916	898	879	861	842	824
28	3 phase	Standard Static	809	794	778	763	748	733	717	702	687	671	656
		Medium Static	918	901	885	868	851	835	818	801	784	768	751
		High Static	1064	1045	1025	1006	987	968	948	929	910	890	871
30	3 phase	Standard Static	840	825	809	794	779	764	748	733	718	702	687
		Medium Static	1008	990	971	953	934	916	898	879	861	842	824
		High Static	1151	1128	1104	1081	1058	1035	1011	988	965	941	918

NOTE: Do not adjust pulley further than 5 turns open.

Factory settings

## DAMPER, BAROMETRIC RELIEF AND PE PERFORMANCE

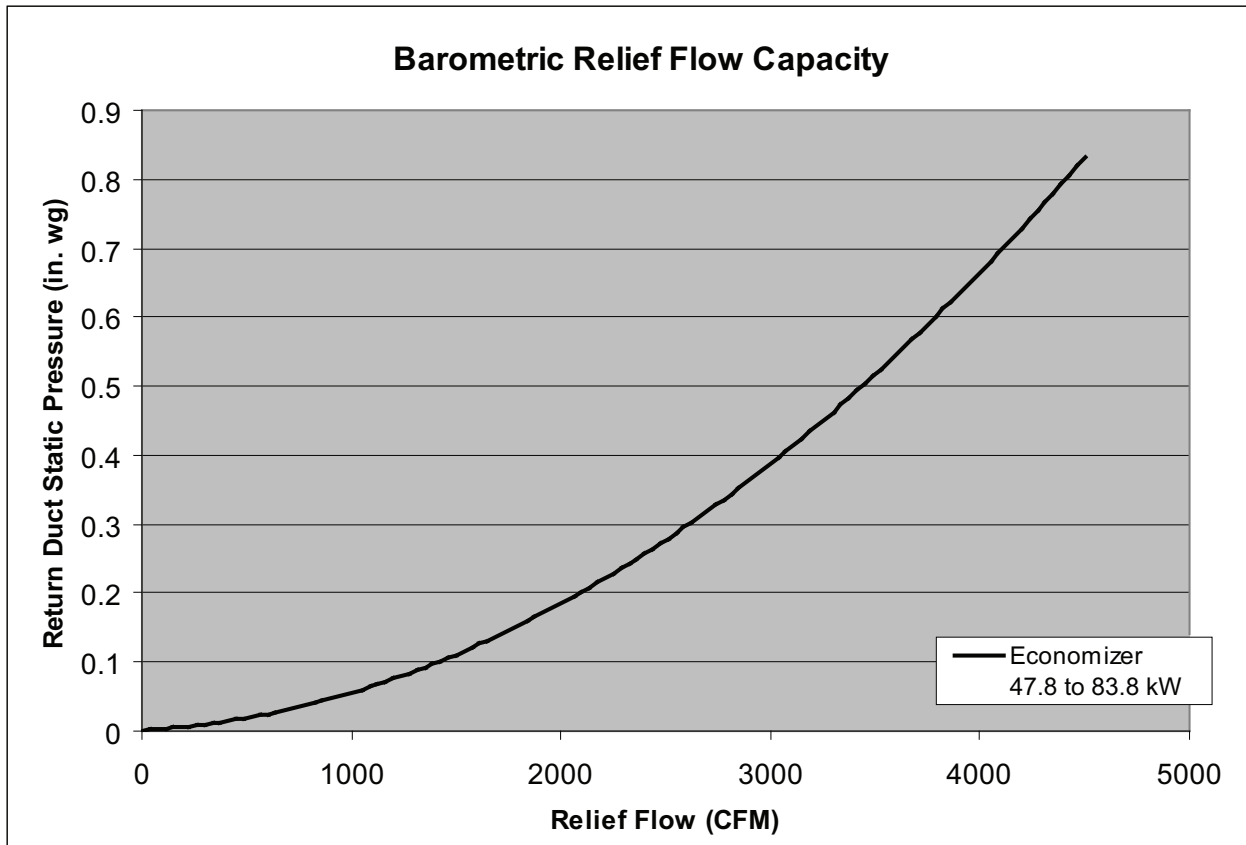
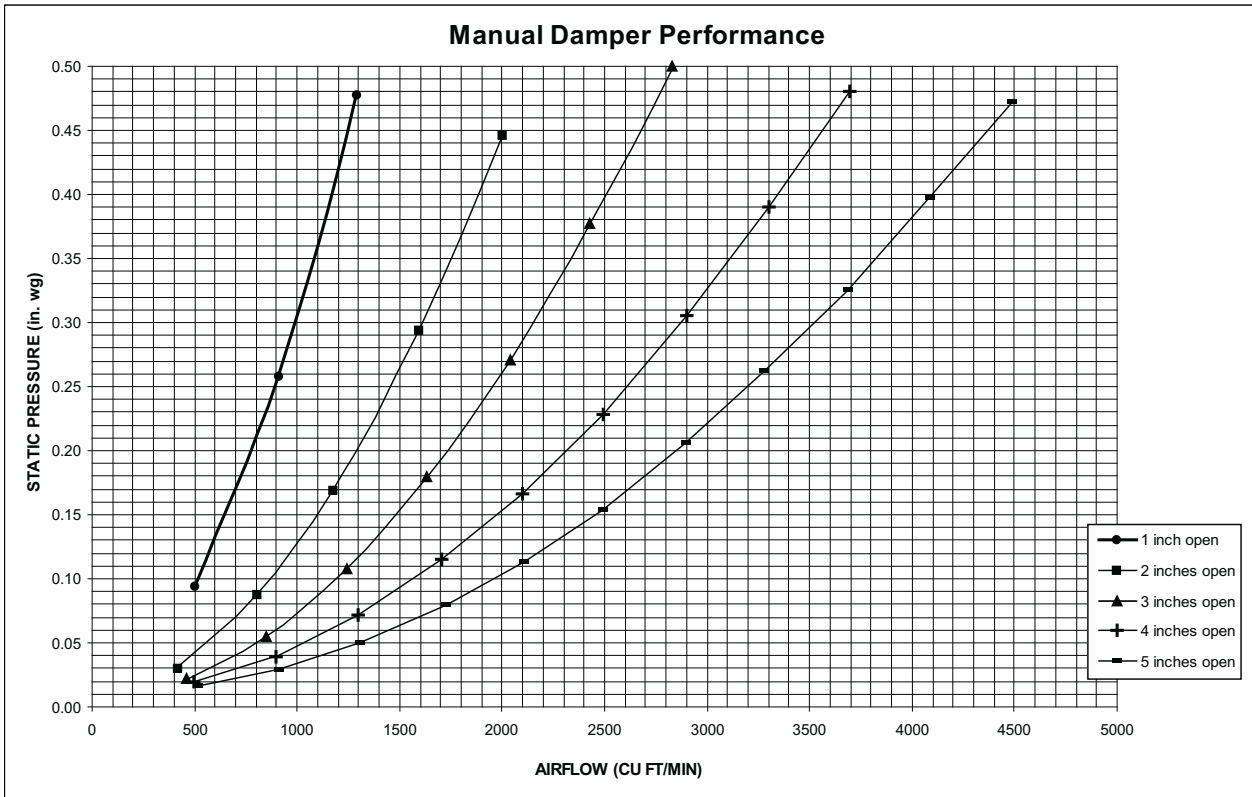

## DAMPER, BAROMETRIC RELIEF AND PE PERFORMANCE (cont)

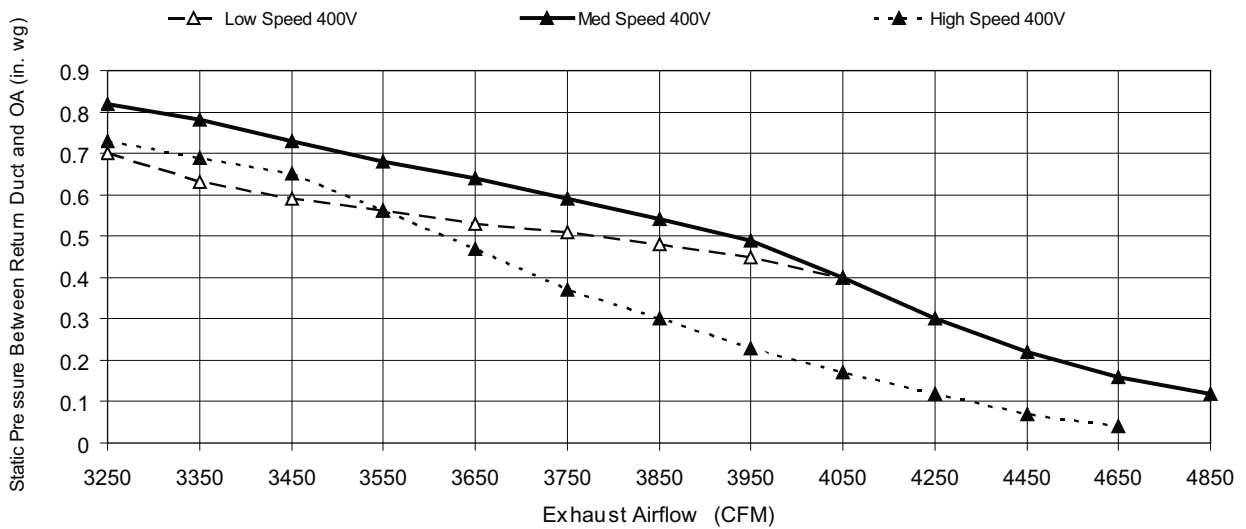
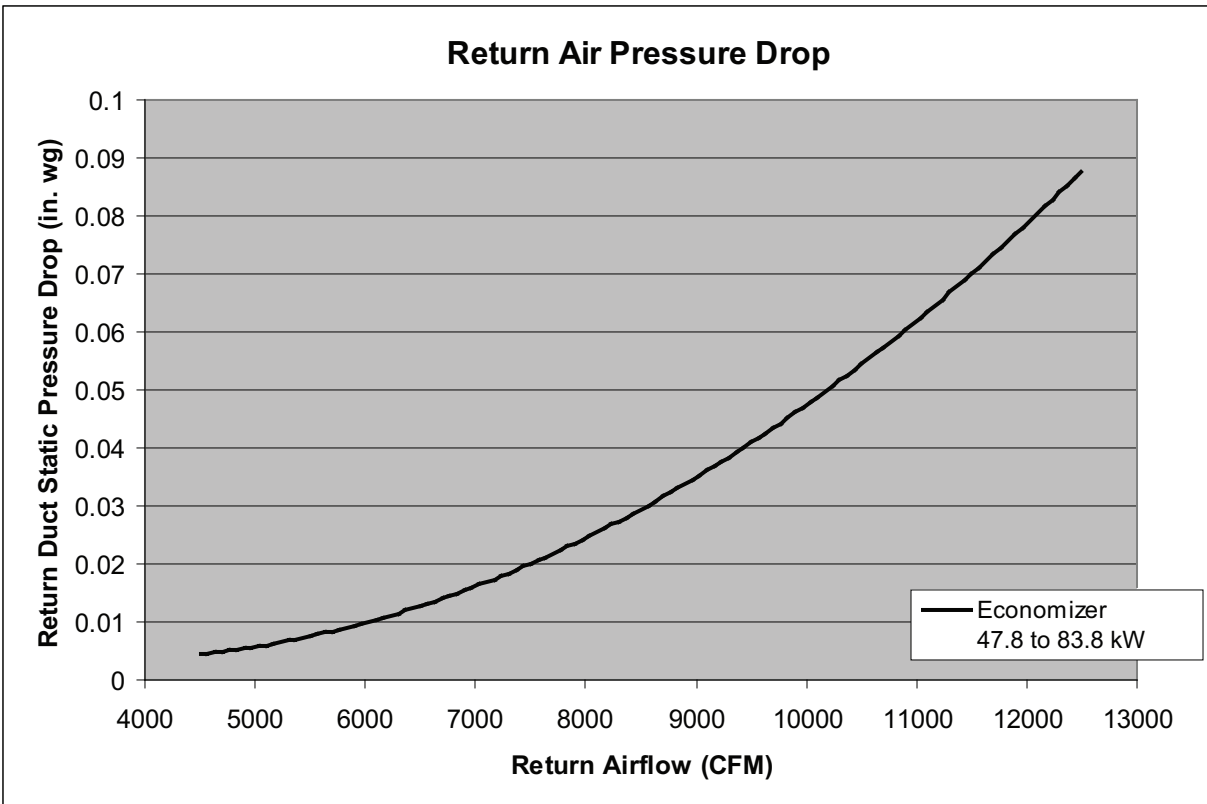

## 2-STAGE COOLING

50TC UNIT	V-Ph-Hz	VOLTAGE RANGE		COMP 1		COMP 2		OFM (ea)		IFM				
		MIN	MAX	RLA	LRA	RLA	LRA	WATTS	FLA	TYPE	Max WATTS	Max AMP Draw	EFF at Full Load	FLA
17	400-3-50	360	440	14.7	95	16.7	111	347	0.8	STD	2278	3.57	81.3%	3.4
										MED	2694	4.62	83.8%	4.4
										HIGH	5644	4.62	89.5%	4.4
20	400-3-50	360	440	14.7	95	16.7	111	347	0.8	STD	2694	7.98	83.8%	7.6
										MED	5644	7.98	89.5%	7.6
										HIGH	5644	7.98	89.5%	7.6
24	400-3-50	360	440	18.6	118	14.7	95	347	0.8	STD	5644	7.98	89.5%	7.6
										MED	5644	7.98	89.5%	7.6
										HIGH	10601	11.97	91.7%	11.4
28	400-3-50	360	440	18.6	118	18.6	118	347	0.8	STD	5644	11.97	89.5%	11.4
										MED	5644	11.97	89.5%	11.4
										HIGH	10601	10.71	91.7%	10.2
30	400-3-50	360	440	21.8	140	21.8	140	347	0.8	STD	5644	10.71	89.5%	10.2
										MED	10601	17.01	91.7%	16.2
										HIGH	11384	18.165	91.7%	17.3

## ELECTRICAL DATA — MCA/MOCP

UNIT	NOM. V-Ph-Hz	IFM TYPE	ELEC. HTR		POWER EXHAUST FLA	NO C.O. or UNPWR C.O.							
			Nom (kW)	FLA		NO P.E.				w/ P.E. (pwrd fr/unit)			
						MCA	MOCP	DISC. SIZE		MCA	MOCP	DISC. SIZE	
								FLA	LRA			FLA	LRA
17	400-3-50	STD	—	—	3.1	41.4	50	43	240	47.6	60	50	252
			17.4	25.1		41.4	50	43	240	47.6	60	50	252
			34.7	50.1		66.9	70	62	240	74.6	80	69	252
			52.1	75.2		79.5	90	90	240	87.2	90	98	252
		MED	—	—	3.1	42.4	50	44	249	48.6	60	51	261
			17.4	25.1		42.4	50	44	249	48.6	60	51	261
			34.7	50.1		68.1	70	63	249	75.9	80	70	261
			52.1	75.2		80.7	90	92	249	88.5	100	99	261
		HIGH	—	—	3.1	45.6	60	48	253	51.8	60	55	265
			17.4	25.1		45.6	60	48	253	51.8	60	55	265
			34.7	50.1		72.1	80	66	253	79.9	80	73	265
			52.1	75.2		84.7	100	95	253	92.5	100	102	265
20	400-3-50	STD	—	—	3.1	42.4	50	44	249	48.6	60	51	261
			17.4	25.1		42.4	50	44	249	48.6	60	51	261
			34.7	50.1		68.1	70	63	249	75.9	80	70	261
			52.1	75.2		80.7	90	92	249	88.5	100	99	261
	MED	—	—	3.1	45.6	60	48	253	51.8	60	55	265	
		17.4	25.1		45.6	60	48	253	51.8	60	55	265	
		34.7	50.1		72.1	80	66	253	79.9	80	73	265	
		52.1	75.2		84.7	100	95	253	92.5	100	102	265	
	HIGH	—	—	3.1	48.2	60	51	253	54.4	60	58	265	
		17.4	25.1		48.2	60	51	253	54.4	60	58	265	
		34.7	50.1		75.4	80	69	253	83.1	90	76	265	
		52.1	75.2		88.0	100	98	253	95.7	100	105	265	
24	400-3-50	STD	—	—	3.1	48.8	60	51	262	55.0	60	58	274
			17.4	25.1		48.8	60	51	262	55	60	58	274
			34.7	50.1		72.1	80	66	262	79.9	80	73	274
			52.1	75.2		84.7	100	95	262	92.5	100	102	274
		MED	—	—	3.1	51.4	60	54	262	57.6	70	61	274
			17.4	25.1		51.4	60	54	262	57.6	70	61	274
			34.7	50.1		75.4	80	69	262	83.1	90	76	274
			52.1	75.2		88.0	100	98	262	95.7	100	105	274
		HIGH	—	—	3.1	58.0	70	61	303	64.2	80	68	315
			17.4	25.1		58.0	70	61	303	64.2	80	68	315
			34.7	50.1		83.6	90	77	303	91.4	100	84	315
			52.1	75.2		96.2	110	106	303	104	110	113	315
28	400-3-50	STD	—	—	3.1	52.7	60	55	285	58.9	70	62	297
			17.4	25.1		52.7	60	55	285	58.9	70	62	297
			34.7	50.1		72.1	80	66	285	79.9	80	73	297
			52.1	75.2		84.7	100	95	285	92.5	100	102	297
		MED	—	—	3.1	55.3	60	58	285	61.5	80	65	297
			17.4	25.1		55.3	60	58	285	61.5	80	65	297
			34.7	50.1		75.4	80	69	285	83.1	90	76	297
			52.1	75.2		88.0	100	98	285	95.7	100	105	297
		HIGH	—	—	3.1	61.9	80	66	326	68.1	80	73	338
			17.4	25.1		61.9	80	66	326	68.1	80	73	338
			34.7	50.1		83.6	90	77	326	91.4	100	84	338
			52.1	75.2		96.2	110	106	326	104	110	113	338
30	400-3-50	STD	—	—	3.1	64.1	80	67	333	70.3	90	75	345
			17.4	25.1		64.1	80	67	333	70.3	90	75	345
			34.7	50.1		75.4	80	69	333	83.1	90	76	345
			52.1	75.2		88.0	100	98	333	95.7	100	105	345
		MED	—	—	3.1	70.7	90	75	374	76.9	90	82	386
			17.4	25.1		70.7	90	75	374	76.9	90	82	386
			34.7	50.1		83.6	90	77	374	91.4	100	84	386
			52.1	75.2		96.2	110	106	374	104	110	113	386
		HIGH	—	—	3.1	71.1	90	75	392	77.3	90	83	404
			17.4	25.1		71.1	90	75	392	77.3	90	83	404
			34.7	50.1		84.1	90	77	392	91.9	100	85	404
			52.1	75.2		96.7	110	106	392	104.5	110	113	404



## TYPICAL POWER DIAGRAM

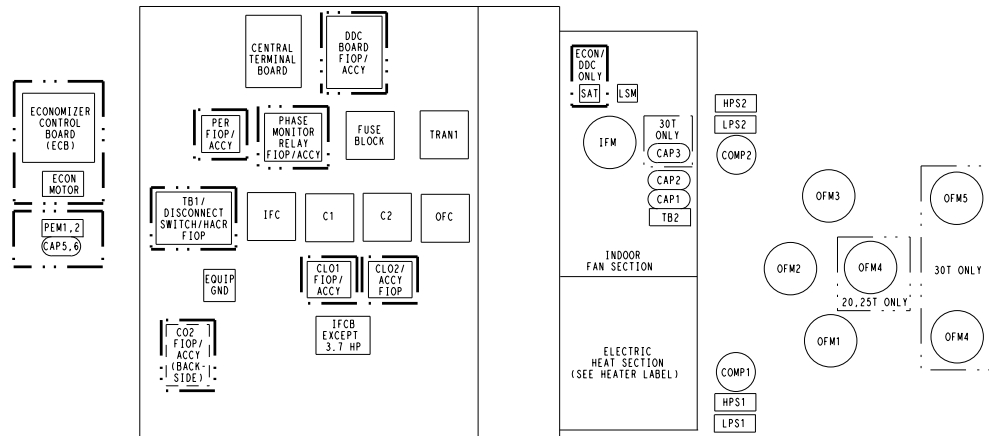
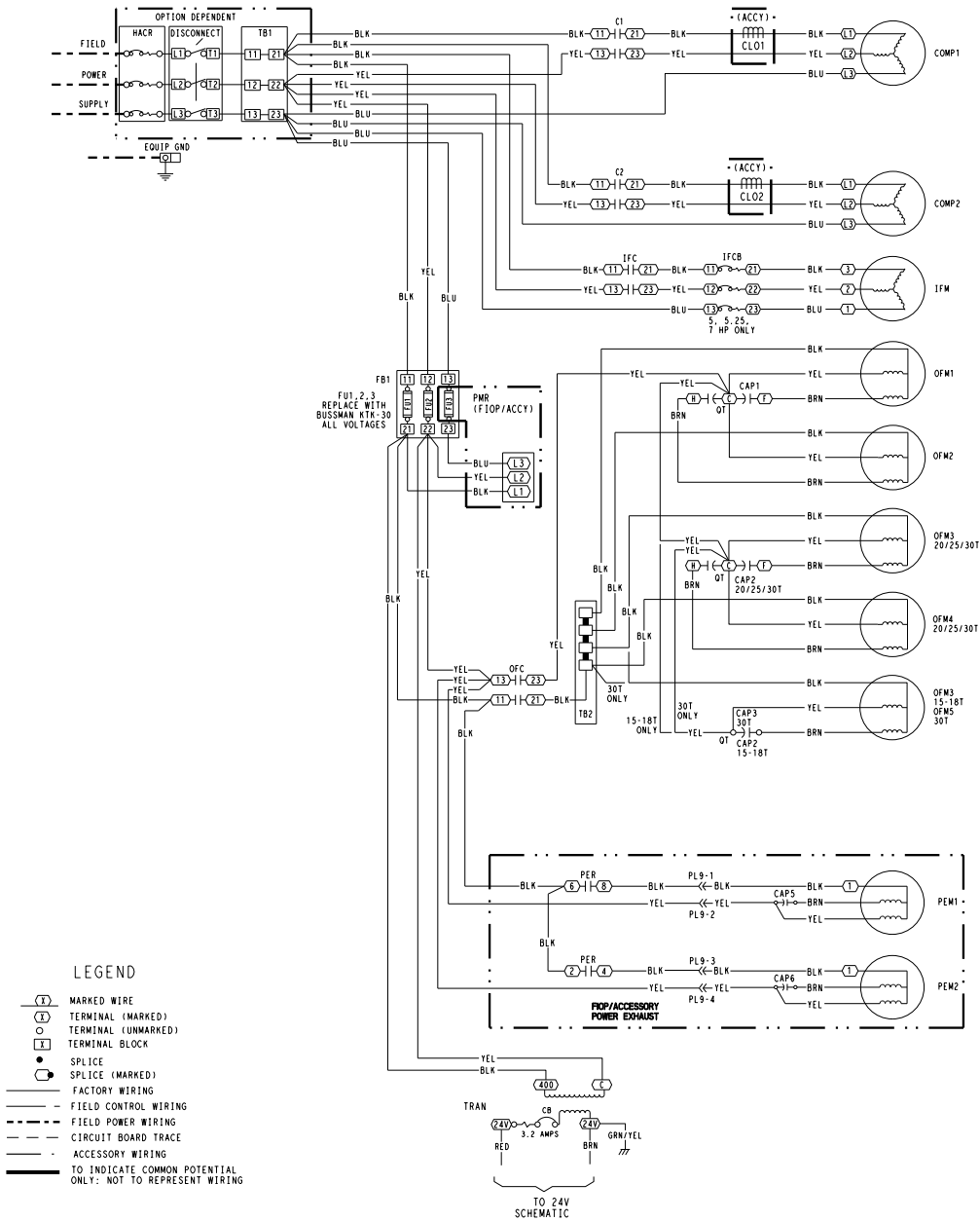

## TYPICAL CONTROL DIAGRAM

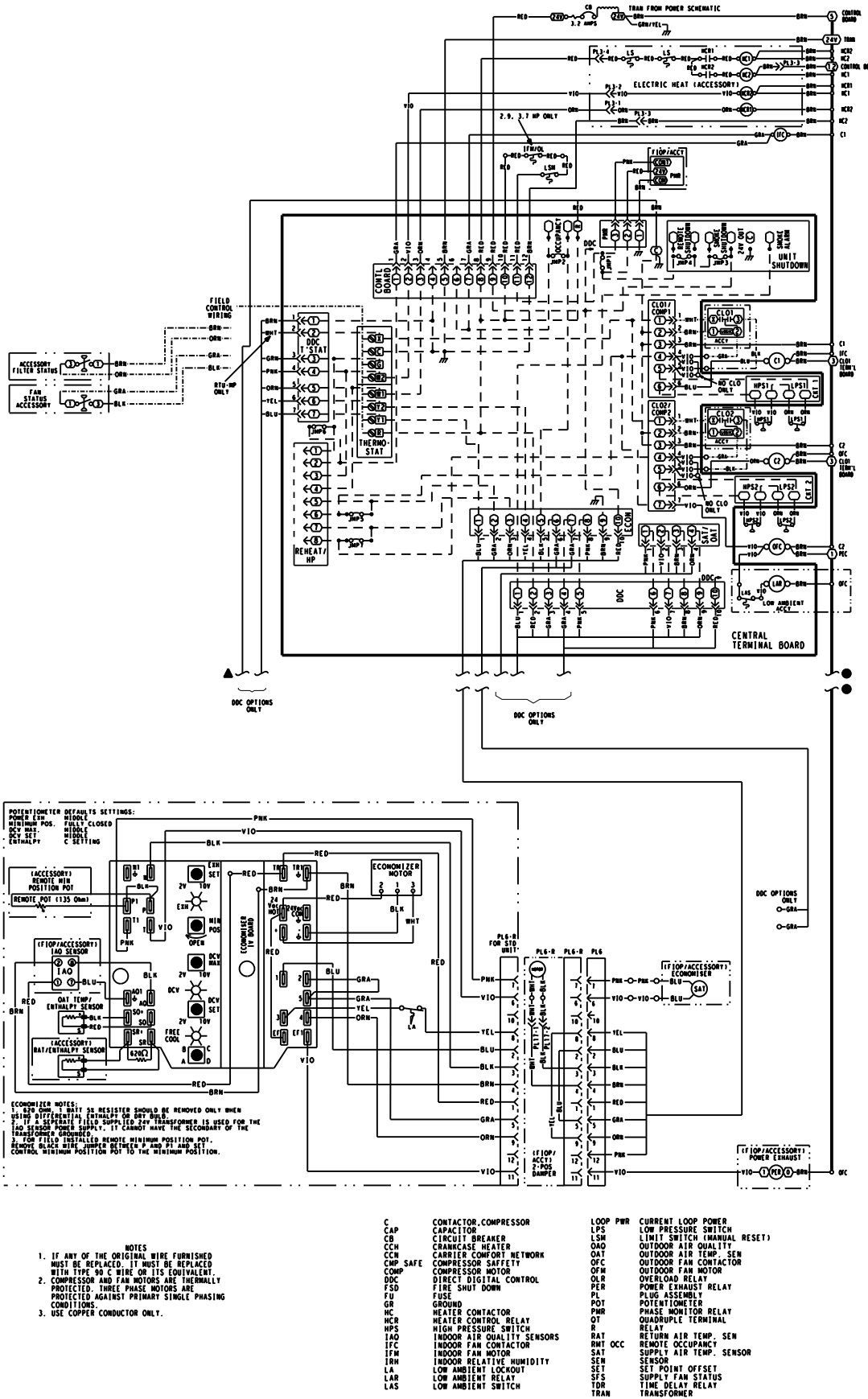

# Sequence of operation

## General

The sequence below describes the sequence of operation for an electro-mechanical unit with and without a factory installed EconoMi\$er IV (called “economizer” in this sequence). For information regarding a direct digital controller, see the start-up, operations, and troubleshooting manual for the applicable controller.

## Electro-mechanical units with no economizer

### Cooling

When the thermostat calls for cooling, terminals G and Y1 are energized. As a result, the indoor-fan contactor (IFC) and the compressor contactor (C1) are energized, causing the indoor-an motor (IFM), compressor #1, and outdoor fan to start. If the unit has 2 stages of cooling, the thermostat will additionally energize Y2. The Y2 signal will energize compressor contactor #2 (C2), causing compressor #2 to start. Regardless of the number of stages, the outdoor-fan motor runs continuously while unit is cooling.

### Heating

NOTE: The 50TC is sold as cooling only. If electric heaters are required, use only factory-approved electric heaters. They will operate as described below.

Units have either 1 or 2 stages of electric heat. When the thermostat calls for heating, power is applied to the W1 terminal at the unit. The unit control will energize the indoor fan contactor and the first stage of electric heat. On units with two-stage heating, when additional heating is required, the second stage of electric heat (if equipped) will be energized when power is applied at the W2 terminal on the unit.

## Electro-mechanical units with an economizer

### Cooling

When free cooling is not available, the compressors will be controlled by the zone thermostat. When free cooling is available, the outdoor-air damper is modulated by the EconoMi\$er IV control to provide a 10°C (50°F) to 13°C (55°F) mixed-air temperature into the zone. As the mixed air temperature fluctuates above 13°C (55°F) or below 10°C (50°F) dampers will be modulated (open or close) to bring the mixed-air temperature back within control. If mechanical cooling is utilized with free cooling, the outdoor-air damper will maintain its current position at the time the compressor is started. If the increase in cooling capacity causes the mixed-air temperature to drop below 9°C (45°F), then the outdoor-air damper position will be decreased to the minimum position. If the mixed-air temperature continues to fall, the outdoor-air damper will close. Control returns to normal once the mixed-air

temperature rises above 9°C (48°F). The power exhaust fans will be energized and de-energized, if installed, as the outdoor-air damper opens and closes.

If field-installed accessory CO<sub>2</sub> sensors are connected to the EconoMi\$er IV control, a demand controlled ventilation strategy will begin to operate. As the CO<sub>2</sub> level in the zone increases above the CO<sub>2</sub> setpoint, the minimum position of the damper will be increased proportionally. As the CO<sub>2</sub> level decreases because of the increase in fresh air, the outdoor-air damper will be proportionally closed. For EconoMi\$er IV operation, there must be a thermostat call for the fan (G). If the unit is occupied and the fan is on, the damper will operate at minimum position. Otherwise, the damper will be closed.

When the EconoMi\$er IV control is in the occupied mode and a call for cooling exists (Y1 on the thermostat), the control will first check for indoor fan operation. If the fan is not on, then cooling will not be activated. If the fan is on, then the control will open the EconoMi\$er IV damper to the minimum position.

On the initial power to the EconoMi\$er IV control, it will take the damper up to 2-1/2 minutes before it begins to position itself. After the initial power-up, further changes in damper position can take up to 30 seconds to initiate. Damper movement from full closed to full open (or vice versa) will take between 1-1/2 and 2-1/2 minutes. If free cooling can be used as determined from the appropriate changeover command (switch, dry bulb, enthalpy curve, differential dry bulb, or differential enthalpy), then the control will modulate the dampers open to maintain the mixed-air temperature setpoint at 10°C (50°F) to 13°C (55°F). If there is a further demand for cooling (cooling second stage - Y2 is energized), then the control will bring on compressor stage 1 to maintain the mixed-air temperature setpoint. The EconoMi\$er IV damper will be open at maximum position. EconoMi\$er IV operation is limited to a single compressor.

### Heating

The sequence of operation for the heating is the same as an electromechanical unit with no economizer. The only difference is how the economizer acts. The economizer will stay at the Economizer Minimum Position while the evaporator fan is operating. The outdoor-air damper is closed when the indoor fan is not operating.

Refer to Service and Maintenance Manual for further details.

Note about this specification:

These specifications are written in “Masterformat” as published by the Construction Specification Institute. Please feel free to copy this specification directly into your building spec.



## Cooling Only/Electric Heat Packaged Rooftop HVAC Guide Specifications

Size Range: **47.8 to 83.8 kW (14 to 25 nominal tons)**

Carrier Model Number: **50TC17-30**

### Part 1 — 23 06 80 Schedules for Decentralized HVAC Equipment

1.01 23 06 80.13 Decentralized Unitary HVAC Equipment Schedule

A. 23 06 80.13.A. Rooftop unit schedule

1. Schedule is per the project specification requirements.

### Part 2 — 23 07 16 HVAC Equipment Insulation

2.01 23 07 16.13 Decentralized, Rooftop Units:

A. 23 07 16.13.A. Evaporator fan compartment:

1. Interior cabinet surfaces shall be insulated with a minimum 13mm (1/2-in.) thick, minimum .7 kg (1-1/2 lb) density, flexible fiberglass insulation bonded with a phenolic binder, neoprene coated on the air side.
2. Insulation and adhesive shall meet NFPA 90A requirements for flame spread and smoke generation.

B. 23 07 16.13.B. Electric heat compartment:

1. Aluminum foil-faced fiberglass insulation shall be used.
2. Insulation and adhesive shall meet NFPA 90A requirements for flame spread and smoke generation.

### Part 3 — 23 09 13 Instrumentation and Control Devices for HVAC

3.01 23 09 13.23 Sensors and Transmitters

A. 23 09 13.23.A. Thermostats

1. Thermostat must:
  - a. energize both “W” and “G” when calling for heat.
  - b. have capability to energize 2 different stages of cooling, and 2 different stages of heating.
  - c. include capability for occupancy scheduling.

### Part 4 — 23 09 23 Direct-digital Control system for HVAC

4.01 23 09 23.13 Decentralized, Rooftop Units:

A. 23 09 23.13.A. PremierLink™ controller

1. Shall be ASHRAE 62-2001 compliant.
2. Shall accept 18-32VAC input power.

3. Shall have an operating temperature range from -40°C (-40°F) to 70°C (158°F), 10% - 95% RH (non-condensing).
  4. Shall include an integrated economizer controller to support an economizer with 4 to 20 mA actuator input and no microprocessor controller.
  5. Controller shall accept the following inputs: space temperature, setpoint adjustment, outdoor air temperature, indoor air quality, outdoor air quality, indoor relative humidity, compressor lock-out, fire shutdown, enthalpy, fan status, remote time clock/door switch.
  6. Shall accept a CO<sub>2</sub> sensor in the conditioned space, and be Demand Control Ventilation (DCV) ready.
  7. Shall provide the following outputs: Economizer, fan, cooling stage 1, cooling stage 2, heat stage 1, heat stage 2, heat stage 3/ exhaust/ reversing valve/ dehumidify/ occupied.
  8. Unit shall provide surge protection for the controller through a circuit breaker.
  9. Shall be Internet capable, and communicate at a Baud rate of 38.4K or faster
  10. Shall have an LED display independently showing the status of activity on the communication bus, and processor operation.
  11. Shall include an EIA-485 protocol communication port, an access port for connection of either a computer or a Carrier technician tool, an EIA-485 port for network communication to intelligent space sensors and displays, and a port to connect an optional LonWorks plug-in communications card.
  12. Shall have built-in Carrier Comfort Network® (CCN) protocol, and be compatible with other CCN devices, including ComfortVIEW controllers.
  13. Shall have built-in support for Carrier technician tool.
  14. Software upgrades will be accomplished by local download. Software upgrades through chip replacements are not allowed.
  15. Shall be shock resistant in all planes to 5G peak, 11ms during operation, and 100G peak, 11ms during storage.
  16. Shall be vibration resistant in all planes to 1.5G at 20-300 Hz.
  17. Shall support a bus length of 1219m (4000-ft) max, 60 devices per 305m (1000-ft) section, and 1 RS-485 repeater per 1000ft sections.
  18. Shall support English language only. Supports Metric or Imperial units of measure.
- B. 23 09 23.13.B. RTU Open Multi-Protocol, direct digital controller:
1. Shall be ASHRAE 62-2001 compliant.

2. Shall accept 18-30VAC, 50Hz, and consumer 15VA or less power.
3. Shall have an operating temperature range from -40°C (-40°F) to 54°C (130°F), 10% - 90% RH (non-condensing).
4. Shall include built-in protocol for BACnet<sup>1</sup> (MS/TP and PTP modes), Modbus<sup>2</sup> (RTU and ASCII), Johnson N2 and LonWorks<sup>3</sup>. LonWorks Echelon processor required for all Lon applications shall be contained in separate communication board.
5. Shall allow access of up to 62 network variables (SNVT). Shall be compatible with all open controllers
6. Baud rate Controller shall be selectable using a dipswitch.
7. Shall have an LED display independently showing the status of serial communication, running, errors, power, all digital outputs, and all analog inputs.
8. Shall accept the following inputs: space temperature, setpoint adjustment, outdoor air temperature, indoor air quality, outdoor air quality, compressor lock-out, fire shutdown, enthalpy switch, and fan status/filter status/ humidity/ remote occupancy.
9. Shall provide the following outputs: economizer, fan, cooling stage 1, cooling stage 2, heat stage 1, heat stage 2, heat stage 3/ exhaust/ reversing valve.
10. Shall have built-in surge protection circuitry through solid state polyswitches. Polyswitches shall be used on incoming power and network connections. Polyswitches will return to normal when the “trip” condition clears.
11. Shall have a battery back-up capable of a minimum of 10,000 hours of data and time clock retention during power outages.
12. Shall have built-in support for Carrier technician tool.
13. Shall include an EIA-485 protocol communication port, an access port for connection of either a computer or a Carrier technician tool, an EIA-485 port for network communication to intelligent space sensors and displays, and a port to connect an optional LonWorks communications card.
14. Software upgrades will be accomplished by either local or remote download. No software upgrades through chip replacements are allowed.
15. Shall support English language only. Only supports Imperial units of measure.

## Part 5 — 23 09 33 Electric and Electronic Control System for HVAC

### 5.01 23 09 33.13 Decentralized, Rooftop Units:

#### A. 23 09 33.13.A. General:

1. Shall be complete with self-contained low-voltage control circuit protected by a resettable circuit breaker on the 24-v transformer side. Transformer shall have 75VA capability.
2. Shall utilize color-coded wiring.
3. Shall include a central control terminal board to conveniently and safely provide connection points for vital control functions such as: smoke detectors, phase monitor, economizer, thermostat, DDC control options, and low and high pressure switches.
4. Unit shall include a minimum of one 8-pin screw terminal connection board for connection of control wiring.

#### B. 23 09 33.23.B. Safeties:

1. Compressor over-temperature, over current.
2. Low-pressure switch.
  - a. Units shall have different sized connectors for the circuit 1 and circuit 2 low and high pressure switches. They shall physically prevent the cross-wiring of the safety switches between circuits 1 and 2.
  - b. Low pressure switch shall use different color wire than the high pressure switch. The purpose is to assist the installer and service technician to correctly wire and or trouble-shoot the rooftop unit.
3. High-pressure switch.
  - a. Units compressors shall have different sized connectors for the circuit 1 and circuit 2 low and high pressure switches. They shall physically prevent the cross-wiring of the safety switches between circuits 1 and 2.
  - b. High pressure switch shall use different color wire than the low pressure switch. The purpose is to assist the installer and service technician to correctly wire and or trouble-shoot the rooftop unit.
4. Automatic reset, motor thermal overload protector.

## Part 6 — 23 09 93 Sequence of Operations for HVAC Controls

### 6.01 23 09 93.13 Decentralized, Rooftop Units:

#### A. 23 09 93.13 INSERT SEQUENCE OF OPERATION

## Part 7 — 23 40 13 Panel Air Filters

### 7.01 23 40 13.13 Decentralized, Rooftop Units:

#### A. 23 40 13.13.A. Standard filter section

1. Shall consist of factory-installed, low velocity, throwaway 51mm (2-in.) thick fiberglass filters of commercially available sizes.

1. BACview is a registered trademark of Automated Logic Corporation.

2. Modbus is a registered trademark of Schneider Electric.

3. LonWorks is a registered trademark of Echelon Corporation.

2. Unit shall use only one filter size. Multiple sizes are not acceptable.
3. Filters shall be accessible through a dedicated, weather tight panel.
4. 4-in filter capabilities shall be capable with pre engineered and approved Carrier filter track field installed accessory. This kit requires field furnished filters.

## Part 8 — 23 81 19 Self-Contained Air Conditioners

### 8.01 23 81 19.13 Medium-Capacity Self-Contained Air Conditioners (50TC-D17 to 30)

#### A. 23 81 19.13.A. General

1. Outdoor, rooftop mounted, electrically controlled, heating and cooling unit utilizing a(n) hermetic scroll compressor(s) for cooling duty and gas combustion for heating duty.
2. Factory assembled, single-piece heating and cooling rooftop unit. Contained within the unit enclosure shall be all factory wiring, piping, controls, and special features required prior to field start-up.
3. Unit shall use environmentally safe, Puron refrigerant.
4. Unit shall be installed in accordance with the manufacturer's instructions.
5. Unit must be selected and installed in compliance with local, state, and federal codes.

#### B. 23 81 19.13.B. Quality Assurance

1. Unit meets ASHRAE 90.1 minimum efficiency requirements.
2. Unit shall be rated in accordance with AHRI Standard 340/360.
3. Unit shall be designed to conform to ASHRAE 15.
4. Unit shall be UL-tested and certified in accordance with ANSI Z21.47 Standards and UL-listed and certified under Canadian standards as a total package for safety requirements.
5. Insulation and adhesive shall meet NFPA 90A requirements for flame spread and smoke generation.
6. Unit casing shall be capable of withstanding 500-hour salt spray exposure per ASTM B117 (scribed specimen).
7. Unit casing shall be capable of withstanding Federal Test Method Standard No. 141 (Method 6061) 5000-hour salt spray.
8. Unit shall be designed in accordance with ISO 9001, and shall be manufactured in a facility registered by ISO 9001.
9. Roof curb shall be designed to conform to NRCA Standards.
10. Unit shall be subjected to a completely automated run test on the assembly line. The data for each unit will be stored at the factory, and must be available upon request.

11. Unit shall be designed in accordance with UL Standard 1995, including tested to withstand rain.
12. Unit shall be constructed to prevent intrusion of snow and tested to prevent snow intrusion into the control box up to 40 mph.
13. Unit shake tested to assurance level 1, ASTM D4169 to ensure shipping reliability.

#### C. 23 81 19.13.C. Delivery, Storage, and Handling

1. Unit shall be stored and handled per manufacturer's recommendations.
2. Lifted by crane requires either shipping top panel or spreader bars.
3. Unit shall only be stored or positioned in the upright position.

#### D. 23 81 19.13.D. Project Conditions

1. As specified in the contract.

#### E. 23 81 19.13.E. Project Conditions

1. As specified in the contract.

#### F. 23 81 19.13.F. Operating Characteristics

1. Unit shall be capable of starting and running at 52°C (125°F) ambient outdoor temperature, meeting maximum load criteria of AHRI Standard 340/360 at ± 10% voltage.
2. Compressor with standard controls shall be capable of operation from 4°C (40°F), ambient outdoor temperatures. Accessory kits are necessary if mechanically cooling at ambient temperatures below 4°C (40°F).
3. Unit shall discharge supply air vertically or horizontally as shown on contract drawings.
4. Unit shall be factory configured and ordered for vertical supply and return configurations.
5. Unit shall be factory furnished for either vertical or horizontal configuration without the use of special conversion kits. No field kits conversion is possible.
6. Unit shall be capable of mixed operation: vertical supply with horizontal return or horizontal supply with vertical return.

#### G. 23 81 19.13.G. Electrical Requirements

1. Main power supply voltage, phase, and frequency must match those required by the manufacturer.

#### H. 23 81 19.13.H. Unit Cabinet

1. Unit cabinet shall be constructed of galvanized steel, and shall be bonderized and coated with a pre-painted baked enamel finish on all externally exposed surfaces.
2. Unit cabinet exterior paint shall be: film thickness, (dry) 0.076mm/0.003 inches minimum, gloss (per ASTM D523, 16°C/60°F): 60, Hardness: H-2H Pencil hardness.
3. Evaporator fan compartment interior cabinet insulation shall conform to AHRI Standards

- 340/360 minimum exterior sweat criteria. Interior surfaces shall be insulated with a minimum 13mm (1/2-in.) thick, .45 kg (1-lb) density, flexible fiberglass insulation, neoprene coated on the air side. Aluminum foil-faced fiberglass insulation shall be used in the heat compartment.
4. Base of unit shall have a minimum of four locations for factory thru-the-base electrical connections. Connections shall be internal to the cabinet to protect from environmental issues.
  5. Base Rail:
    - a. Unit shall have base rails on a minimum of 2 sides.
    - b. Holes shall be provided in the base rails for rigging shackles to facilitate maneuvering and overhead rigging.
    - c. Holes shall be provided in the base rail for moving the rooftop by fork truck.
    - d. Base rail shall be a minimum of 16 gauge thickness.
  6. Condensate pan and connections:
    - a. Shall be a sloped condensate drain pan made of a non-corrosive material.
    - b. Shall comply with ASHRAE Standard 62.
    - c. Shall use a 19mm (3/4-in.) -14 NPT drain connection at the end of the drain pan. Connection shall be made per manufacturer's recommendations.
  7. Top panel:
    - a. Shall be a multi-piece top panel linked with water tight flanges and interlocking systems.
  8. Electrical Connections
    - a. All unit power wiring shall enter unit cabinet at a single, factory-prepared, knockout location.
    - b. Thru-the-base capability
      - 1) Standard unit shall have a thru-the-base electrical location(s) using a raised, embossed portion of the unit basepan.
      - 2) Optional, factory-approved, water-tight connection method must be used for thru-the-base electrical connections.
      - 3) No basepan penetration, other than those authorized by the manufacturer, is permitted.
  9. Component access panels (standard)
    - a. Cabinet panels shall be easily removable for servicing.
      - b. Unit shall have one factory installed, tool-less, removable, filter access panel.
      - c. Panels covering control box and filters shall have molded composite handles while the blower access door shall have an integrated flange for easy removal.
      - d. Handles shall be UV modified, composite, permanently attached, and recessed into the panel.
      - e. Screws on the vertical portion of all removable access panel shall engage into heat resistant, molded composite collars.
      - f. Collars shall be removable and easily replaceable using manufacturer recommended parts.
- I. 23 81 19.13.I. N/A
  - J. 23 81 19.13.J. Coils
    1. Standard Aluminum fin - Copper Tube Coils:
      - a. Standard evaporator and condenser coils shall have aluminum lanced plate fins mechanically bonded to seamless internally grooved copper tubes with all joints brazed.
      - b. Evaporator coils shall be leak tested to 150 psig, pressure tested to 450 psig, and qualified to UL 1995 burst test at 1775 psig.
      - c. Condenser coils shall be leak tested to 150 psig, pressure tested to 650 psig, and qualified to UL 1995 burst test at 1980 psig.
    2. Optional Pre-coated aluminum-fin condenser coils:
      - a. Shall have a durable epoxy-phenolic coating to provide protection in mildly corrosive coastal environments.
      - b. Coating shall be applied to the aluminum fin stock prior to the fin stamping process to create an inert barrier between the aluminum fin and copper tube.
      - c. Epoxy-phenolic barrier shall minimize galvanic action between dissimilar metals.
    3. Optional Copper-fin evaporator and condenser coils:
      - a. Shall be constructed of copper fins mechanically bonded to copper tubes and copper tube sheets.
      - b. Galvanized steel tube sheets shall not be acceptable.
      - c. A polymer strip shall prevent coil assembly from contacting the sheet metal coil pan to minimize potential for galvanic corrosion between coil and pan.

4. Optional E-coated aluminum-fin evaporator and condenser coils:
  - a. Shall have a flexible epoxy polymer coating uniformly applied to all coil surface areas without material bridging between fins.
  - b. Coating process shall ensure complete coil encapsulation of tubes, fins and headers.
  - c. Color shall be high gloss black with gloss per ASTM D523-89.
  - d. Uniform dry film thickness from 0.8 to 1.2 mil on all surface areas including fin edges.
  - e. Superior hardness characteristics of 2H per ASTM D3363-92A and cross-hatch adhesion of 4B-5B per ASTM D3359-93.
  - f. Impact resistance shall be up to 160 in.-lb (ASTM D2794-93).
  - g. Humidity and water immersion resistance shall be up to minimum 1000 and 250 hours respectively (ASTM D2247-92 and ASTM D870-92).
  - h. Corrosion durability shall be confirmed through testing to be no less than 1000 hours salt spray per ASTM B117-90.
5. Standard All Aluminum Novation Coils:
  - a. Standard condenser coils shall have all aluminum Novation Heat Exchanger Technology design consisting of aluminum multi port flat tube design and aluminum fin. Coils shall be a furnace brazed design and contain epoxy lined shrink wrap on all aluminum to copper connections.
  - b. Condenser coils shall be leak tested to 150 psig, pressure tested to 650 psig, and qualified to UL 1995 burst test at 1980 psig.
6. Optional E-coated aluminum-fin, aluminum tube condenser coils:
  - a. Shall have a flexible epoxy polymer coating uniformly applied to all coil external surface areas without material bridging between fins or louvers.
  - b. Coating process shall ensure complete coil encapsulation, including all exposed fin edges.
  - c. E-coat thickness of 0.8 to 1.2 mil with top coat having a uniform dry film thickness from 1.0 to 2.0 mil on all external coil surface areas, including fin edges, shall be provided.
  - d. Shall have superior hardness characteristics of 2H per ASTM D3363-00 and cross-hatch adhesion of 4B-5B per ASTM D3359-02.
  - e. Shall have superior impact resistance with no cracking, chipping or peeling per NSF/ANSI 51-2002 Method 10.2.
- K. 23 81 19.13.K. Refrigerant Components
  1. Refrigerant circuit shall include the following control, safety, and maintenance features:
    - a. Fixed orifice metering system shall prevent mal-distribution of two-phase refrigerant by including multiple fixed orifice devices in each refrigeration circuit. Each orifice is to be optimized to the coil circuit it serves.
    - b. Refrigerant filter drier.
    - c. Service gauge connections on suction and discharge lines.
    - d. Pressure gauge access through a specially designed screen on the side of the unit.
  2. Compressors:
    - a. Unit shall use one fully hermetic, scroll compressor for each independent refrigeration circuit.
    - b. Compressor motors shall be cooled by refrigerant gas passing through motor windings.
    - c. Compressors shall be internally protected from high discharge temperature conditions.
    - d. Compressors shall be protected from an over-temperature and over-ampereage conditions by an internal, motor overload device.
    - e. Compressor shall be factory mounted on rubber grommets.
    - f. Compressor motors shall have internal line break thermal, current overload and high pressure differential protection.
    - g. Crankcase heaters shall not be required for normal operating range, unless provided by the factory.
- L. 23 81 19.13.L. Filter Section
  1. Filters access is specified in the unit cabinet section of this specification.
  2. Filters shall be held in place by a preformed slide out filter tray, facilitating easy removal and installation.
  3. Shall consist of factory-installed, low velocity, throw-away 51mm (2-in.) thick fiberglass filters.
  4. Filters shall be standard, commercially available sizes.
  5. Only one size filter per unit is allowed.
  6. 102mm (4-in.) filter capability is possible with a field installed pre engineered slide out filter track accessory. 102mm (4-in.) filters are field furnished.
- M. 23 81 19.13.M. Evaporator Fan and Motor
  1. Evaporator fan motor:
    - a. Shall have inherent automatic-reset thermal overload protection or circuit breaker.
    - b. Shall have a maximum continuous bhp rating for continuous duty operation; no safety factors above that rating shall be required.



2. Belt-driven Evaporator Fan:
  - a. Belt drive shall include an adjustable-pitch motor pulley and belt break protection system.
  - b. Shall use rigid pillow block bearing system with lubricate fittings at are accessible or lubrication line.
  - c. Blower fan shall be double-inlet type with forward-curved blades.
  - d. Shall be constructed from steel with a corrosion resistant finish and dynamically balanced.
- N. 23 81 19.13.N. Condenser Fans and Motors
  1. Condenser fan motors:
    - a. Shall be a totally enclosed motor.
    - b. Shall use permanently lubricated bearings.
    - c. Shall have inherent thermal overload protection with an automatic reset feature.
    - d. Shall use a shaft-down design.
  2. Condenser Fans:
    - a. Shall be a direct-driven propeller type fan.
    - b. Shall have aluminum blades riveted to corrosion-resistant steel spiders and shall be dynamically balanced.
- O. 23 81 19.13.O. Special Features, Options and Accessories
  1. Integrated Economizers:
    - a. Integrated, gear-driven parallel modulating blade design type capable of simultaneous economizer and compressor operation.
    - b. Independent modules for vertical or horizontal return configurations shall be available. Vertical and horizontal return modules shall be available as a factory installed option.
    - c. Damper blades shall be galvanized steel with composite gears. Plastic or composite blades on intake or return shall not be acceptable.
    - d. Shall include all hardware and controls to provide free cooling with outdoor air when temperature and/or humidity are below setpoints.
    - e. Shall be equipped with gear driven dampers for both the outdoor ventilation air and the return air for positive air stream control.
    - f. Shall be equipped with low-leakage dampers, not to exceed 2% leakage at 1 in. wg pressure differential.
    - g. Shall be capable of introducing up to 100% outdoor air.
    - h. Shall be equipped with a barometric relief damper capable of relieving up to 100% return air.
    - i. Shall be designed to close damper(s) during loss-of-power situations with spring return built into motor.
  2. Two-Position Motorized Damper
    - a. Damper shall be a Two-Position Damper. Damper travel shall be from the full closed position to the field adjustable %-open setpoint.
    - b. Damper shall include adjustable damper travel from 25% to 100% (full open).
    - c. Damper shall include single or dual blade, gear driven dampers and actuator motor.
    - d. Actuator shall be direct coupled to damper gear. No linkage arms or control rods shall be acceptable.
    - e. Damper will admit up to 100% outdoor air for applicable rooftop units.
    - f. Damper shall close upon indoor (evaporator) fan shutoff and/or loss of power.
    - g. The damper actuator shall plug into the rooftop unit's wiring harness plug. No hard wiring shall be required.
    - h. Outside air hood shall include aluminum water entrainment filter
  3. Manual damper
    - a. Manual damper package shall consist of damper, air inlet screen, and rain hood which can be preset to admit up to 25% outdoor air for year round ventilation.
  - j. Dry bulb outdoor-air temperature sensor shall be provided as standard. Outdoor air sensor setpoint shall be adjustable and shall range from 4 to 38°C (40 to 100°F). Additional sensor options shall be available as accessories.
  - k. The economizer controller shall also provide control of an accessory power exhaust unit. function. Factory set at 100%, with a range of 0% to 100%.
  - l. The economizer shall maintain minimum airflow into the building during occupied period and provide design ventilation rate for full occupancy. A remote potentiometer may be used to override the damper setpoint.
  - m. Dampers shall be completely closed when the unit is in the unoccupied mode.
  - n. Economizer controller shall accept a 2-10Vdc CO<sub>2</sub> sensor input for IAQ/DCV control. In this mode, dampers shall modulate the outdoor-air damper to provide ventilation based on the sensor input.
  - o. Compressor lockout sensor shall open at 2°C (35°F) and close closes at 10°C (50°F).
  - p. Actuator shall be direct coupled to economizer gear. No linkage arms or control rods shall be acceptable.
  - q. Economizer controller shall provide indications when in free cooling mode, in the DCV mode, or the exhaust fan contact is closed.

4. Head Pressure Control Package
  - a. Controller shall control coil head pressure by condenser-fan speed modulation or condenser-fan cycling and wind baffles.
  - b. Shall consist of solid-state control and condenser-coil temperature sensor to maintain condensing temperature between 32°C (90°F) and 43°C (110°F) at outdoor ambient temperatures down to -29°C (-20°F).
5. Condenser Coil Hail Guard Assembly
  - a. Shall protect against damage from hail.
  - b. Shall be louvered style design.
6. Unit-Mounted, Non-Fused Disconnect Switch:
  - a. Switch shall be factory-installed, internally mounted.
  - b. National Electric Code (NEC) and UL approved non-fused switch shall provide unit power shutoff.
  - c. Shall be accessible from outside the unit
  - d. Shall provide local shutdown and lockout capability.
7. Thru-the-Base Connectors:
  - a. Kits shall provide connectors to permit electrical connections to be brought to the unit through the unit basepan.
  - b. Minimum of four connection locations per unit.
8. Fan/Filter Status Switch:
  - a. Switch shall provide status of indoor evaporator fan (ON/OFF) or filter (CLEAN/DIRTY).
  - b. Status shall be displayed either over communication bus (when used with direct digital controls) or with an indicator light at the thermostat.
9. Centrifugal Power Exhaust:
  - a. Power exhaust shall be used in conjunction with an integrated economizer.
  - b. Independent modules for vertical or horizontal return configurations shall be available.
  - c. Horizontal power exhaust is shall be mounted in return ductwork.
  - d. Power exhaust shall be controlled by economizer controller operation. Exhaust fans shall be energized when dampers open past the 0-100% adjustable setpoint on the economizer control.
10. Roof Curbs (Vertical):
  - a. Full perimeter roof curb with exhaust capability providing separate air streams for energy recovery from the exhaust air without supply air contamination.
  - b. Formed galvanized steel with wood nailer strip and shall be capable of supporting entire unit weight.
  - c. Permits installation and securing of ductwork to curb prior to mounting unit on the curb.
11. Adapter Curb (Vertical):
  - a. Full perimeter, fully assembled and welded roof curb with exhaust capability providing separate air streams for energy recovery from the exhaust air without supply air contamination.
  - b. Formed galvanized steel with wood nailer strip and shall be capable of supporting entire unit weight.
  - c. Permits installation of new 50TC17-28 models to past Carrier design curb models: DP,DR,HJ,TM, and TJ. Check with Carrier sales expert of further details and information.
12. High-Static Indoor Fan Motor(s) and Drive(s):
  - a. High-static motor(s) and drive(s) shall be factory-installed to provide additional performance range.
13. Thru-the-Bottom Utility Connectors:
  - a. Kit shall provide connectors to permit gas and electrical connections to be brought to the unit through the basepan.
14. Outdoor Air Enthalpy Sensor:
  - a. The outdoor air enthalpy sensor shall be used to provide single enthalpy control. When used in conjunction with a return air enthalpy sensor, the unit will provide differential enthalpy control. The sensor allows the unit to determine if outside air is suitable for free cooling.
15. Return Air Enthalpy Sensor:
  - a. The return air enthalpy sensor shall be used in conjunction with an outdoor air enthalpy sensor to provide differential enthalpy control.
16. Indoor Air Quality (CO<sub>2</sub>) Sensor:
  - a. Shall be able to provide demand ventilation indoor air quality (IAQ) control.
  - b. The IAQ sensor shall be available in duct mount, wall mount, or wall mount with LED display. The setpoint shall have adjustment capability.
17. Smoke detectors:
  - a. Shall be a Four-Wire Controller and Detector.
  - b. Shall be environmental compensated with differential sensing for reliable, stable, and drift-free sensitivity.
  - c. Shall use magnet-activated test/reset sensor switches.
  - d. Shall have tool-less connection terminal access.
  - e. Shall have a recessed momentary switch for testing and resetting the detector.

- f. Controller shall include:
  - 1) One set of normally open alarm initiation contacts for connection to an initiating device circuit on a fire alarm control panel.
  - 2) Two Form-C auxiliary alarm relays for interface with rooftop unit or other equipment.
  - 3) One Form-C supervision (trouble) relay to control the operation of the Trouble LED on a remote test/reset station.
  - 4) Capable of direct connection to two individual detector modules.
  - 5) Can be wired to up to 14 other duct smoke detectors for multiple fan shut-down applications.
- 18. Winter start kit:
  - a. Shall contain a bypass device around the low pressure switch.
  - b. Shall be required when mechanical cooling is required down to  $-4^{\circ}\text{C}$  ( $25^{\circ}\text{F}$ ).
  - c. Shall not be required to operate on an economizer when below an outdoor ambient of  $4^{\circ}\text{C}$  ( $40^{\circ}\text{F}$ ).
- 19. Time Guard:
  - a. Shall prevent compressor short cycling by providing a 5 minute delay ( $\pm 2$  minutes) before restarting a compressor after shut-down for any reason.
  - b. One device shall be required per compressor.
- 20. Electric Heat:
  - a. Heating Section
    - 1) Heater element open coil resistance wire, nickel-chrome alloy, 7.4mm (0.29-in.) inside diameter, strung through ceramic insulators mounted on metal frame. Coil ends are staked and welded to terminal screw slots.
    - 2) Heater assemblies are provided with integral fusing for protection of internal heater circuits not exceeding 48 amps each. Auto reset thermo limit controls, magnetic heater contactors (24 v coil) and terminal block all mounted in electric heater control box (minimum 18 ga galvanized steel) attached to end of heater assembly.

