

## Performance

- 3.7 g/hour flow
- 23 ft head
- 16.5 ft suction lift
- quiet 21dB
- integral fail safe alarm



MaxiBlue™ uses the same advanced unique technology as the Blue Diamond range. Designed for high humidity environments it benefits from being a small powerful pump that is controlled by our patented sensing technology - only senses when water is present offering an energy efficient drainage solution.

With a higher performance the MaxiBlue™ is ideally suited for mid range air conditioning systems. Its exceptional reliability is backed by a multi year warranty and class leading performance/suction lift has led it to be installed in environments that are both demanding and expensive to access for maintenance.

Model	110v	208v - 230v	Max Current Draw 115v    230v	Hz
Reservoir	X87 - 711	X87 - 721	0.7A    0.035A	60

### Blue Diamond Pumps Inc

4850 Golden Parkway, Suite B, 409, Buford, GA30518, USA  
 Tel: +1 770 831 1122 Fax: +1 770 831 9888  
 Email: info@bluediamondpumps.com  
 www.bluediamondpumps.com

Manufactured by:  
**Charles Austen  
 Pumps Ltd**



**3** year  
 Warranty

### MaxiBlue™ options



Reservoir sensing  
with alarm contacts

Dimensions  
 L x W x H  
 3.5" x 1.42" x 1.59"

### Optional Accessories



16ft Extension Cable



Mounting Feet



MultiTank

## Performance/Technical

Plot of Flow Rate Against Head

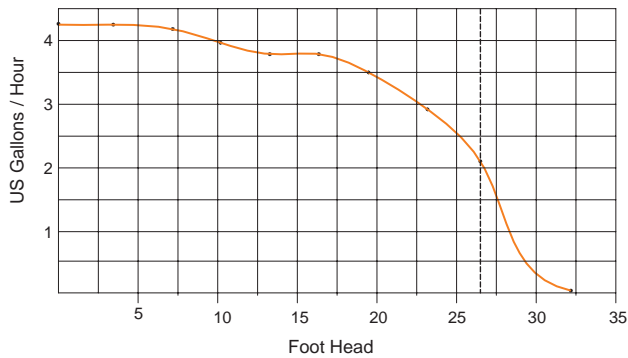

# MaxiBlue™

Fit smart, fit fast, made to last

- Proven rotary diaphragm technology
- Flow rate up to 3.7 g/hr
- Dry suction lift up to 16.5 ft
- Self priming
- Energy efficient
- Exceptionally quiet (21dB) and no vibrations
- Powered by unique water sensors
- Thermally protected
- Integral overflow safety switch

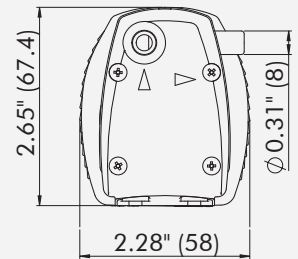

## Specifying MaxiBlue™

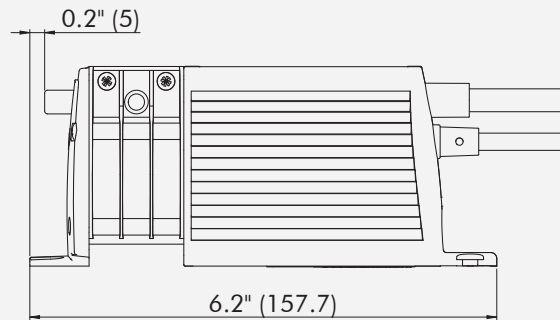
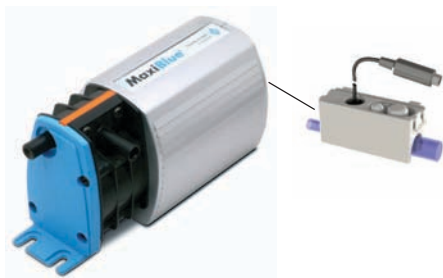

dimensions  
in inches  
weight 1.5lb

## Siting - Installation Possibilities

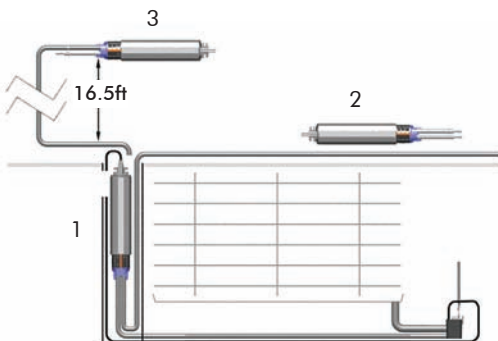

**Reservoir Sensor (energy efficient)** - Connect drip tray to reservoir in which the presence of condensate trips the hi-low solid state level sensors to switch pump on/off. Runs pump only when condensate produced.

Alarm shuts off A/C in fault mode, restarts when clear. Volt free, high level alarm is suitable to connect into City Multi with either CN4F or CN31 drain safety connector, Mr Slim P&M series.

- ① inside line hide
- ② above ceiling
- ③ remote

MaxiBlue™ pump is slim enough to fit into line hide or ducting, powerful enough for distant location and quiet enough for ceiling mounting. It's your choice. Commissioning is so easy, link pump to sensing option with single wire DIN plug and connect in/out tubing provided - plug and play, fit and forget!

## Revolutionary pumping principle



Patented rotary diaphragm pump

Making all these advantages possible is our advanced rotary diaphragm technology. The condensate is drawn into the pump by vacuum then mechanically driven within a re-inforced elastomer diaphragm to the outlet under pressure. This system even tolerates suspended solids and light slurries and also happily runs dry.

**MaxiBlue - Fit smart, fit fast, made to last**

### Blue Diamond Pumps Inc

4850 Golden Parkway, Suite B, 409, Buford, GA30518, USA

Tel: +1 770 831 1122 Fax: +1 770 831 9888

Email: [info@bluediamondpumps.com](mailto:info@bluediamondpumps.com)

[www.bluediamondpumps.com](http://www.bluediamondpumps.com)

Manufactured by:

**Charles Austen  
Pumps Ltd**

