

DW80F800UWS

Stainless Dishwasher

Features

- Quiet Operation – 46 dBA*
- ENERGY STAR® rated: 265 kWh/year
- StormWash™ Heavy Duty Wash System
- Hidden Heating Element
- Double Filtration System
- Electronic Touch Sensor
- Hard Food Disposer
- 3 Spray Wash Arms (Upper, Middle, Lower)
- 6 Wash Cycles and 4 Wash Options
- Twin Fan Condensing Drying System
- 2-piece Silverware Basket
- One Touch Adjustable Racking System
- Stainless Steel Interior

Convenience

- Child Lock
- Rinse Refill Indicator
- Cycle Progress Indicator
- Last Cycle Memory
- Audible End-of-Cycle Signal
- Self-Cleaning Filtration System
- True Hold Door
- Seven sensors (Digital Water Leakage, Low Level Water, Overflow, Sanitize, Turbidity Water Fill)

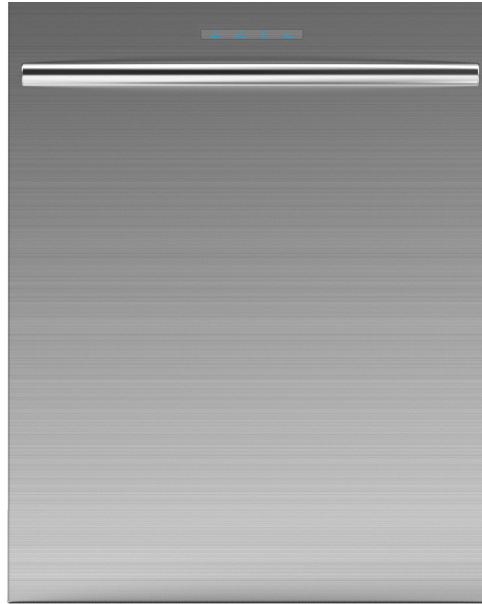

StormWash™



Quiet Operation

Available Color



Stainless Steel

Signature Features



StormWash™

POWERFUL WASHING FOR YOUR TOUGHEST DISHES

- Heavy-duty wash system makes pre-rinsing unnecessary.
- Powerful rotating spray jets positioned to clean dishes at every angle.
- Simply place hard-to-clean items above the StormWash™ wheel on the bottom rack and it scrubs them for you.



Performance (46dBA/water usage)

QUIET. POWERFUL.

- First-rated 46 dBA makes it among the quietest in its class.¹
- A six-layer door and special insulation system significantly minimizes noise during operation.²
- Only 4 gallons of water used per cycle saves on water usage.

¹Class = MSRP point.

²Internal testing = 46 dBA to 48 dBA. Normal conversation = approx. 60 dBA.



ENERGY STAR®

ENERGY EFFICIENT

- This dishwasher is ENERGY STAR® 2013 Tier 1 compliant so that you can save money on your energy and water bills.
- Uses less than 265 kWh of power per year,³ exceeding Department of Energy standards.

³Based on DOE standards.

SAMSUNG

DW80F800UWS

Stainless Dishwasher

Installing Your Dishwasher

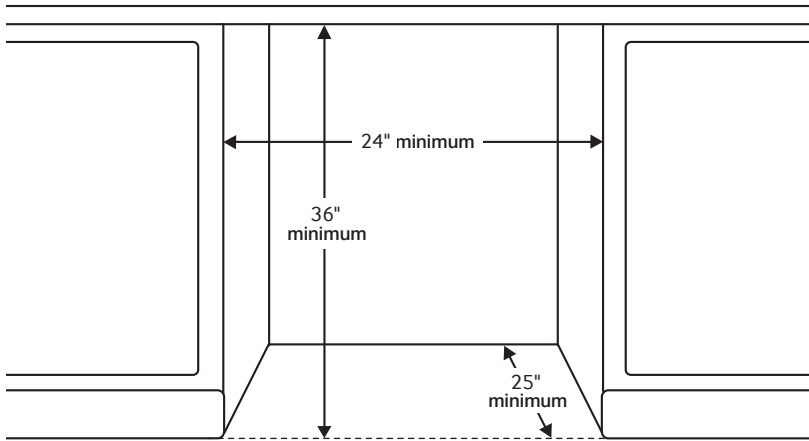

Dimensions

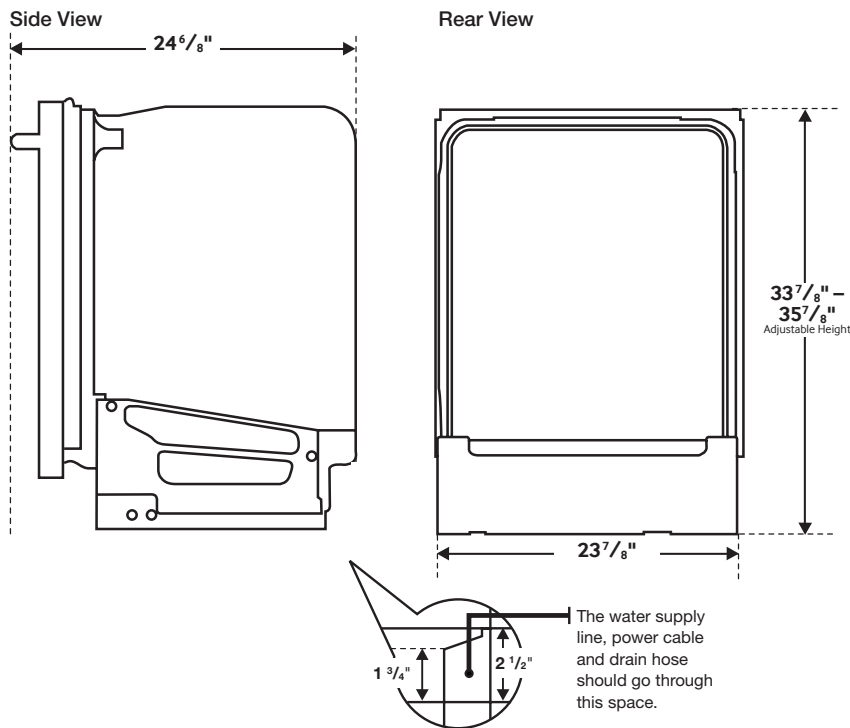

Performance

- 6 Wash Cycles
 - Pots & Pans
 - Smart Auto Wash
 - Quick Plus
 - Heavy
 - Normal
 - Delicate-China/Gentle
- 4 Wash Options
 - Half Load Wash
 - NSF-certified for Sanitize-
 - Delay Start – 24 Hours
 - Power Washing
- 3 Spray Wash Arms (Upper, Middle, Lower)
- Hidden Heating Element
- Double Filtration System
- Electronic Touch Sensor
- Hard Food Disposer
- Twin Fan Condensing Drying System
- Self-Cleaning Filtration System
- Stainless Steel Interior

Convenience

- Child Lock
- Rinse Refill Indicator
- Cycle Progress Indicator
- Last Cycle Memory
- Audible End-of-Cycle Signal
- True Hold Door
- Seven Sensors (Digital Water Leakage, Low Level Water, Overflow, Sanitize, Turbidity, Water Fill)
- 2 Silverware Baskets
- One Touch Adjustable Racking System

Warranty

One (1) Year All Parts and Labor
Five (5) Year Limited on Printed Circuit Board and Interior Nylon Racks
Lifetime Limited Warranty on Stainless Steel Door Liner and Tub for Leakage

Product Dimensions & Weight (WxHxD)

Dimensions (adjustable):
23 7/8" x 33 7/8" – 35 7/8" x 24 6/8"

Weight: 108 lbs.

Shipping Dimensions & Weight (WxHxD)

Dimensions:
27 1/4" x 37 3/4" x 28 7/8"

Weight: 124.5 lbs.

Color	Model #	UPC Code
Stainless Steel	DW80F800UWS	887276986272

SAMSUNG