

NZ30K6330RS

30" Electric Cooktop

Features

- Wi-Fi Connectivity
- Flexible Cooktop:
 - Two Dual Elements (9"/6" Rapid Boil™ and 8"/5")
 - Two Single Elements (7")
 - Single Melt Element (6")
- 9.5 kW Total Power

Convenience

- Hot Surface Indicator Light
- Easy-To-Clean Glass, Ceramic Cooktop
- Dishwasher-Safe Knobs

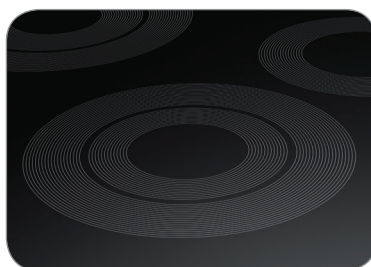

Rapid Boil™



LED Illuminated Backlit Knobs

Available Colors



Stainless Steel (shown)



Black Stainless Steel

Signature Features

RAPID BOIL™

- Up to 3.3 kW power element offers intense heat and precise control to quickly boil water or maintain a low even simmer.

FLEXIBLE COOKTOP

- Whether you're boiling water, melting chocolate or simmering sauce, there's an element for your needs.

LED ILLUMINATED BACKLIT KNOBS

- Visually lets you know your cooktop is on, even at a distance.

NZ30K6330RS

30" Electric Cooktop

Installing Your Cooktop

Can be installed over a single oven.

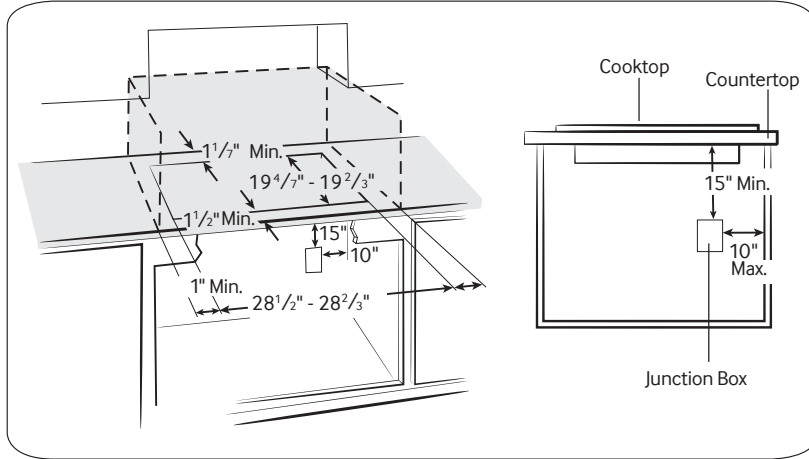

Total Power

9.5 kW

Power Source

240V / 60 Hz / 40A

Electric Cooktop

- Left Front: 7", 1.5 kW
- Left Rear: 7", 1.5 kW
- Right Front: 8"/5", 2 kW
- Right Rear: 6", 1.2 kW (Melt)
- Center: 9"/6", 3.3 kW (Rapid Boil™)

Warranty

One (1) Year All Parts and Labor

Product Dimensions & Weight (WxHxD)

Outside (Max) Cooktop Dimensions:

$30'' \times 5\frac{1}{10}'' \times 21\frac{1}{4}''$

Cooktop Cut-Out Dimensions:

$28\frac{1}{2}'' \times 5\frac{1}{10}'' \times 19\frac{4}{7}''$

Weight: 35.7 lbs.

Shipping Dimensions & Weight (WxHxD)

Dimensions:

$34\frac{3}{16}'' \times 8\frac{1}{2}'' \times 25\frac{1}{16}''$

Weight: 48.5 lbs.

Color

Stainless Steel

Model

NZ30K6330RS

UPC Code

887276183329

Black Stainless Steel

NZ30K6330RG

887276183312

Dimensions

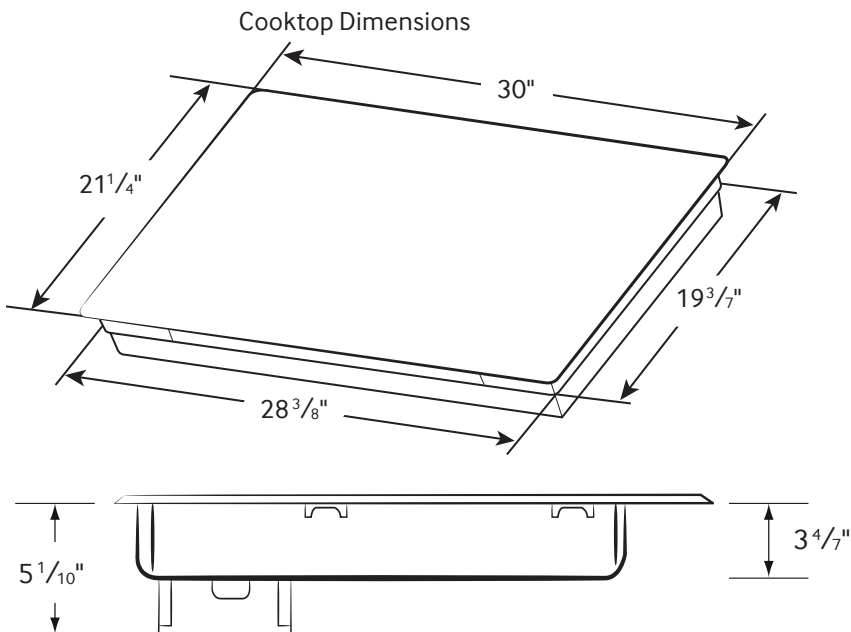

Cut-Out Dimensions of Countertop

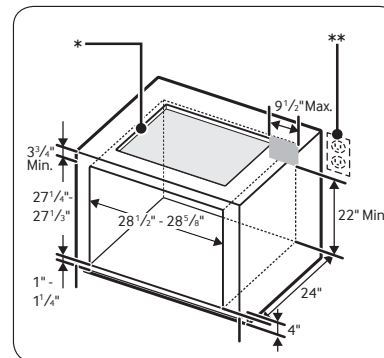

* See built-in oven installation for complete installation instructions. See label on top of approved built-in oven models.

** Refer to installation manual of oven.

SAMSUNG

Actual color may vary. Design, specifications, and color availability are subject to change without notice. Non-metric weights and measurements are approximate.

©2017 Samsung Electronics America, Inc. 85 Challenger Road, Ridgefield Park, NJ 07660. Tel: 800-SAMSUNG. samsung.com. Samsung is a registered trademark of Samsung Electronics Co., Ltd.