

17 cu. ft. Upright Convertible Refrigerator / Freezer



Signature Features

Convertible Refrigerator / Freezer

- A convertible freezer, that can switch between fridge or freezer, is perfect for any home, no matter what their needs.



Digital Display Thermostat Controller

- Digital control panel with temperature display allows you know more about the interior temperature.
4 mode design can meet your actual need for special use/storage.

Big Capacity for Organization

- Full-width, adjustable glass shelf and door bins provide you large capacity. Design it to what you need to store.

Available Color

-  White
-  Grey
-  Stainless Look



Convertible Refrigerator/Freezer



Digital Display Thermostat Controller

Design

- Frost-free Design
- Convertible Zone
- Digital Display Buttons
- 17 cu.ft. Capacity
- High-Efficiency LED Lighting
- Adjustable Leveling Legs

Convenience

- Temperature Display On Door
- 4 Spill-Proof Shelves
- 1 Wire Basket
- 4 Door Bins
- Child Lock
- Door Alarm
- 4 Temperature Mode for Option:
FRIDGE Mode - between 32°F and 46°F
SUBZERO Mode- between 25°F and 18°F
FREEZE Mode - between 7°F and -11°F
FRIDGE Mode - between 32°F and 46°F
FAST FREEZE Mode - under -18°F

Performance

- All-Around Cooling
- Surround Air-Flow, No Frost
- Large Freezing Capacity
- Cool Tight Door

Rating

DOE Rated: 484 kWh/yr
cCSA_{US} Certified
CFC Free

17 cu. ft. Upright Convertible Refrigerator / Freezer

Installation Requirements

- Solid, level surface without carpeting or flooring that may obstruct ventilation
- Away from direct sunlight
- Adequate room for opening and closing the door
- Away from a heat source
- Room for maintenance and servicing
- Temperature range: between 38°F (3°C) and 110°F (43°C)

Dimensions

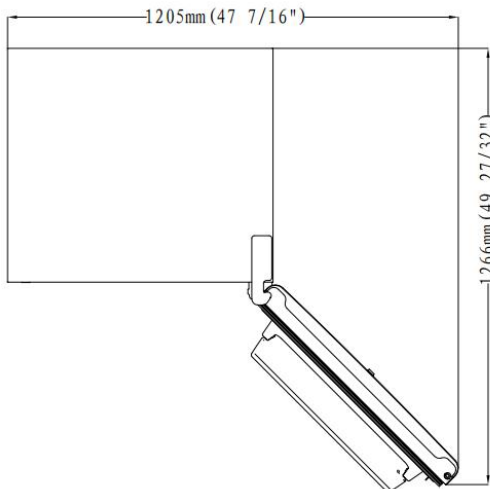
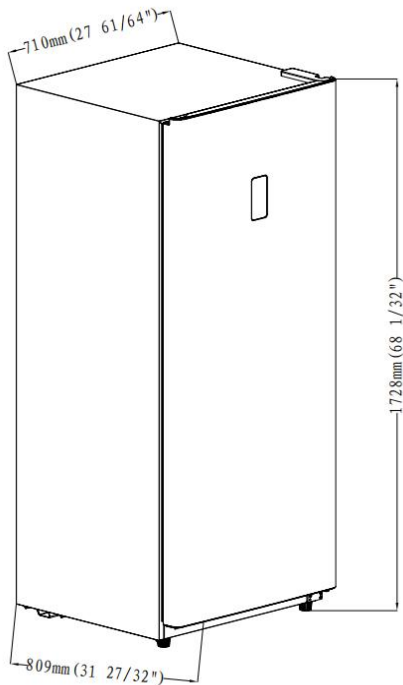

Total Capacity: 14 cu. ft.

- 4 Spill-Proof Shelves
- 1 Wire Basket
- 4 Door Bins
- High-Efficiency LED Lighting
- Adjustable Freeze Mode: Temperatures between 7°F and -11°F (-2.2°F default temperature)
- Adjustable Fridge Mode: Temperatures between 32°F and 46°F (39.2°F default temperature)
 - Mode Select - Switch between Fridge, Subzero, Freeze and Fast Freeze Modes

Warranty

One (1) Year Parts and Labor

To make a warranty claim, please email support2@curtiscs.com or call 1-800-968-9853.

Product Dimensions & Weight

Dimensions (WxHxD with door closed):

27 ⁶¹/₆₄" x 68 ¹/₃₂" x 31 ²⁷/₃₂"

Dimensions (WxHxD with max opening angel):

47 ⁷/₁₆" x 68 ¹/₃₂" x 49 ²⁷/₃₂"

Weight: 165 lbs

Shipping Dimensions & Weight (WxHxD)

Dimensions: 30 ⁵/₆₄" x 70 ²⁵/₃₂" x 33 ¹⁷/₆₄"

Weight: 180 lbs

Color

White

Model

HBFRF1798-WHITE

UPC Code

058465827045

Shipping Dimensions & Weight (WxHxD)

Dimensions: 30 ⁵/₁₆" x 72 ¹/₄" x 33 ¹⁷/₆₄"

Weight: 187 lbs

Color

White

Model

HBFRF1798-WHITE-3COM

UPC Code

058465827045

※ Actual color may vary. Design, specifications, and color availability are subject to change without notice. Non-metric weights and measurements are approximate.

Hamilton Beach® is a registered trademark of Hamilton Beach Brands, Inc. used under license by Curtis International Ltd.

For service assistance and product information, please call: 1-800-968-9853. Curtis International Ltd. 7045 BECKETT DRIVE, UNIT 15, MISSISSAUGA, ON, L5S 2A3 www.curtisint.co