

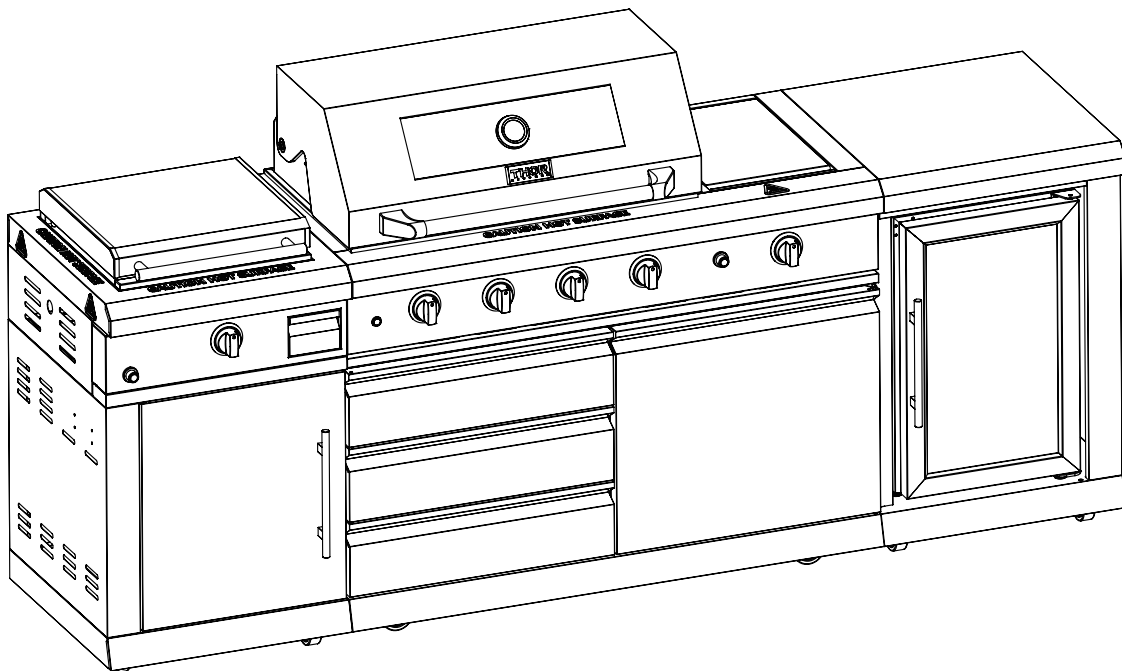

3-Piece Modular Outdoor kitchen with Griddle Burner and Beverage Installation Manual

MODEL# GL034B



Warning: Excessive weight hazard!

Use two or more people to move, assemble or install cabinets and shelves to avoid back injury. Do not leave children unattended near cabinets.

Save for electrical inspector's use.

Installer: Leave installation instructions with the homeowner.

Homeowner: Retain the instructions for future reference.



IMPORTANT SAFETY WARNINGS



**THIS MANUAL MUST REMAIN WITH
THIS PRODUCT AT ALL TIMES**



CAUTION

Read and follow all safety statements, assembly instructions, use and care directions before attempting to assemble and cook.

INSTALLER OR ASSEMBLER/CONSUMER

This manual should be kept with the grill at all times.

WARNING

Failure to follow all of the Manufacturer's instructions could result in hazardous fires, explosions, property damage, or serious personal injury or even death.

Follow all leak check procedures carefully prior to operation of grill, even if grill was dealer assembled. Do not try to light this grill without reading the Lighting Instructions section of this manual.

DANGER

1. If you smell gas:
 - a. Shut off gas to the appliance.
 - b. Extinguish any open flame.
 - c. Open lid.
 - d. If odor continues, keep away from the appliance and immediately call your gas supplier or your fire department.
2. Do not store or use gasoline or other flammable liquids or vapors in the vicinity of this or any other appliance.
3. LP gas cylinder not connected for use shall not be stored in the vicinity of this or any other appliance.

CAUTION

IN DIRECT SUN, AND IN OPERATION, YOUR GRILL'S STAINLESS STEEL AND PAINTED STEEL PARTS CAN BECOME VERY HOT.



THIS GRILL IS FOR OUTDOOR USE ONLY



If stored indoors, detach and leave cylinder outdoors.
If the instruction are not followed exactly, a fire causing death or serious injury may occur.

CAUTION

Some parts may contain sharp edges, especially as noted in the manual. Wear protective gloves during assembly and usage of this appliance.

For residential use ONLY. Do not use for commercial cooking.



WARNING

Do not attempt to repair or alter the hose and regulator or valve assembly for any assumed defect or for any type of retro fit or conversion. Any modifications to this assembly will void your warranty and create the risk of a gas leak and fire. Use only authorized replacement parts supplied by the manufacturer, for your model.



Minimum ambient operating temperature: -4°F (-20 °C)

TABLE OF CONTENT

INSTALLATION / ADDITIONAL WARNINGS	4
LP GAS CYLINDER HOOK-UPS AND WARNINGS	5
SAFETY HOSE AND REGULATOR:	
Installing LP gas cylinder	6
Regulator reset procedure	8
Leak test procedure	9~10
LIGHTING INSTRUCTIONS	11~12
START GRILLING	13~14
PREVENTION	15
MAINTENANCE	16~17
STORING YOUR GRILL	18
TROUBLESHOOTING	19
ASSEMBLY INSTRUCTIONS	22~29
WARRANTY AND SERVICE	30

-  **DANGER:** Indicates an imminently hazardous situation which, if not avoided, will result in death or serious injury.
-  **WARNING:** Be alert to the possibility of serious bodily injury if the instructions are not followed. Be sure to read and carefully follow all of the messages.
-  **CAUTION:** Indicates a potentially hazardous situation which, if not avoided, may result in minor or moderate injury.

CALIFORNIA PROPOSITION 65 WARNING

-  **WARNING:** This product can expose you to chemicals including lead and lead compounds, which are known to the State of California to cause cancer and birth defects or other reproductive harm. For more information go to www.P65Warnings.ca.gov
-  **WARNING: CONTAINS LEAD. MAY BE HARMFUL IF EATEN OR CHEWED. COMPLIES WITH FEDERAL STANDARDS. KEEP OUT OF REACH OF CHILDREN.**

INSTALLATION

Installation must conform with local codes or, in the absence of local codes, with either the National Fuel Gas Code, ANSI Z223.1/NFPA 54, Natural Gas and Propane Installation Code, CSA B149.1, or Propane Storage and Handling for Recreational Vehicles, ANSI A 119.2/NFPA 1192, and CSA Z240 RV Series, Recreational Vehicle Code, as applicable.

ADDITIONAL WARNINGS

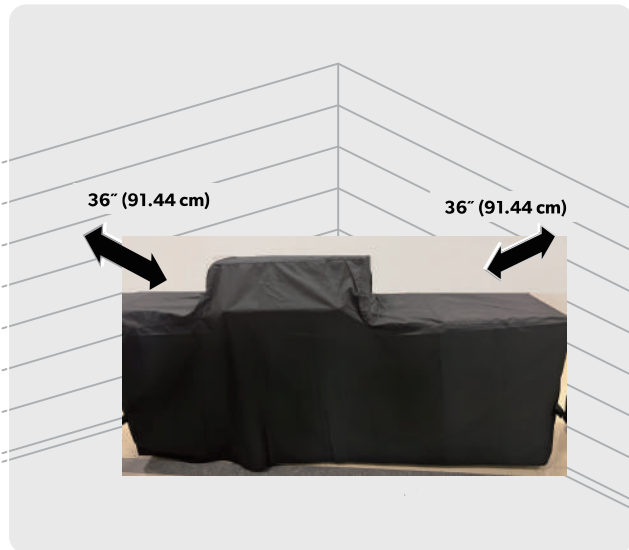

MINIMUM CLEARANCE TO ADJACENT COMBUSTIBLE MATERIALS:

MINIMUM OF **36" (91.44 CM)** FROM FURTHEST PROTRUDING EDGE ON ALL SIDES OF THE GRILL.



DO ENSURE GRILL IS POSITIONED ON LEVEL SURFACE.

MINIMUM CLEARANCE OF 36" ON BOTH SIDES AND REAR OF THE GRILL.

- **DO NOT** operate this grill under or near any overhanging or unprotected construction, aluminum siding, windows, or fencing.
- **DO NOT** use in enclosed spaces such as carport, garage, porch or covered patio.
- **DO NOT** obstruct the flow of combustion and ventilation air to the grill.
- **DO NOT** place grill against a wall or other solid structure.
- **DO** always keep the area around this grill clean and clear of any and all combustible materials such as gasoline or other inflammable liquids, paper or oily rags.
- **DO** remember this grill is for **OUTDOOR USE ONLY** and is **NOT** for use on any boat or recreational vehicle.
- **DO** use this grill outdoors in a well-ventilated area, at least **36" (91.44 cm)** from any dwelling or building.
- **DO** always close LP cylinder valve and remove coupling nut before moving LP cylinder from specified operating position.
- **DO** check burner flames regularly.
- **DO NOT** attempt to light burner with lid closed. A buildup of non-ignited gas inside a closed grill is hazardous.
- **DO NOT** leave your grill unattended while in operation.
- **DO NOT** use while under the influence of drugs or alcohol.
- **DO NOT** store any spare LP gas cylinder, full or empty, under or near your grill.
- **DO NOT** allow children or pets to play anywhere near the grill.
- **DO NOT** block ventilation holes in the sides or back of grill.
- **DO NOT** use charcoal or ceramic briquettes in this gas grill.
- **DO NOT USE GRILL UNTIL A LEAK-TEST AND A SAFETY CHECK IS COMPLETED.**

LP GAS CYLINDER REQUIREMENTS

DO NOT connect to a LP gas cylinder exceeding 9 kg (20 lb) capacity or use a cylinder with any other type of cylinder valve connection device.

LP gas supply cylinder must be constructed and marked in accordance with the specifications for LP gas cylinders of the U.S. Department of Transportation (DOT) or the National Standard of Canada, CAN/CSA-B339, Cylinders Spheres and Tubes for the Transportation of Dangerous Goods.

GAS HOOK-UP'S AND WARNINGS

WHAT IS LIQUID PETROLEUM (LP) GAS?

- Liquefied petroleum gas, also called LP gas, liquid propane or propane is non-toxic, odorless and colorless when produced. For your safety, LP gas has been given an odor (similar to rotten cabbage) so that it can be detected.
- LP gas is highly flammable and may ignite unexpectedly when mixed with air.

LP GAS CYLINDER VALVE MUST HAVE:

- Shut-off valve with a correct cylinder valve output as specified in current standards. CSA/ANSI Z21.58-22 Outdoor Cooking Gas Appliances.
- Type 1 outlet compatible with regulator or grill. The type 1 valve is easily recognized by the large external thread on the outside of the valve.
- Safety relief valve with direct connection to the vapor space of the cylinder.
- UL listed Overfill Protection Device (OPD). This OPD safety feature is identified by a unique triangular hand wheel.
- Use only LP cylinders equipped with this type of valve.
- A device for vapor withdrawal.
- A collar to protect the LP gas cylinder shut-off valve.
- A ring on the bottom of the LP gas cylinder to secure it to the support assembly.
- Place dust cap on cylinder valve outlet whenever the cylinder is not in use. Only install the type of dust cap on the cylinder valve outlet that is provided with the cylinder valve. Other types of caps or plugs may result in leakage of propane.

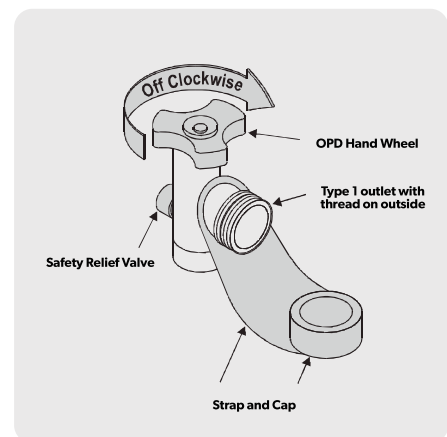

! ATTENTION

Any attempt to connect a regulator to any connectors other than the mating TYPE-1 connector could result in fires, explosions, injuries, or property damage. Use only LP gas cylinders equipped with this type of valve. DO NOT connect to a LP gas cylinder exceeding 9 kg capacity or use a cylinder with any other type of cylinder valve connection device. Before opening LP cylinder valve, check the coupling nut for tightness.

LP GAS CYLINDER RUBBER SEAL INSPECTION

LP GAS WARNINGS:

- Inspect LP gas cylinder valve rubber seal for cracks, wear or deterioration prior to use. A damaged rubber seal can cause a gas leak, possibly resulting in an explosion, fire or severe bodily harm.
- Inspection should be done each time LP gas cylinder is connected to grill, has been refilled, exchanged or has not been used for more than 60 days.
- Do not use a LP gas cylinder with a damaged rubber seal. Exchange LP gas cylinder or have rubber seal replaced at a qualified propane filling station.

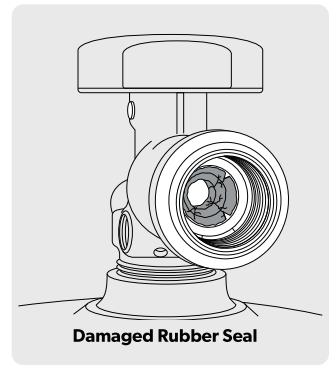
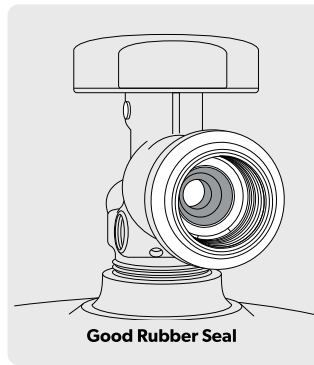

INSTALLING THE LP GAS CYLINDER

1. Check that the cylinder shut-off valve is closed, by turning knob clockwise.
2. Loosen the tank tray locking screw/cylinder into LP gas cylinder tray in bottom of cabinet.
3. Orient LP gas cylinder so valve opening faces forward.
4. Tighten the locking screw clockwise against the bottom collar of the propane tank to secure the tank

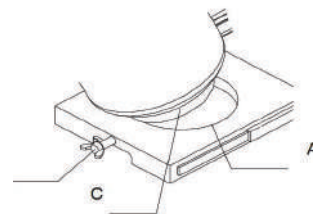
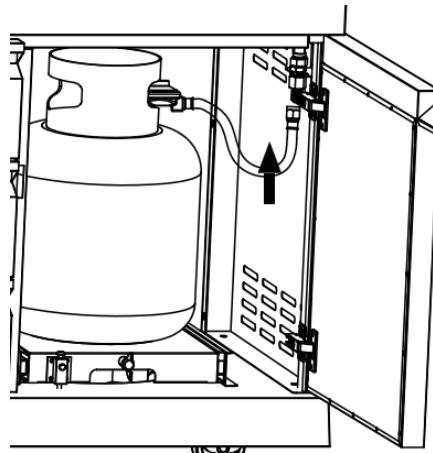

A. Locking screw
B. Tank tray
C. 20lb LP gas fuel tank tray

! DANGER

- NEVER store a spare LP gas cylinder, empty or full, under or near the appliance.
- Never fill a cylinder beyond 80% full.
- An over filled or improperly stored cylinder is a hazard due to possible gas release from the safety relief valve. This could cause an intense fire or explosion with risk of property damage, serious injury or death.
- Do not store objects or materials inside the grill cabinet enclosure that would block the flow of combustion air to the underside of either the control panel or the firebox.
- If you see, smell or hear gas escaping, immediately get away from the LP gas cylinder/ grill and call your fire department.



LP GAS WARNINGS:

- Always turn LP gas cylinder valve off when the grill is not in use.
- Always handle the LP gas cylinder valve with the utmost care.
- Never connect an unregulated LP gas cylinder to the grill.
- Always keep the LP gas cylinder in use, securely fastened in an upright position.
- Never expose the LP gas cylinder to direct sunlight or excessive heat.
- Never insert any kind of object into the valve outlet as this may cause damage to the Backcheck. A damaged Backcheck can leak resulting in fires, explosions, property damage, severe injuries or death.
- Do not store an LP gas cylinder in enclosed spaces such as a carport, garage, porch, covered patio or other building. Make sure the storage area has a lot of ventilation.
- Do not store an LP gas cylinder in an area where children play.

INSTALLING THE LP GAS CYLINDER

HOSE AND REGULATOR

Your grill is equipped with a Type 1 connection device with the following features:

1. The system will not allow gas flow from cylinder until a positive connection to valve has been made.
NOTE: The cylinder valve and all control knobs must be turned "OFF" before any connection is made or removed.
2. A regulator flow limiting device, when activated, restricts the flow of gas to 10 cubic feet per hour. If the flow limiting device is activated, perform Regulator Reset Procedure.
3. A thermal element built into the regulator supply hose will shut the flow of gas between 240—300°F (115.5—148.8°C).

NOTE: If you are experiencing performance issues such a low heat, low flame, or difficulty lighting, you have likely tripped your regulators flow limiting feature. Follow steps for regulator reset, on page 8.

CAUTION: The gas pressure regulator provided with this appliance must be used.

CONNECTING HOSE AND REGULATOR

⚠ ATTENTION

Visually inspect hose prior to each use for damage, excess wear, or deterioration. If found, replace hose before using your grill. Only the manufacturer's supplied replacement should be used.

1. Inspect LP gas cylinder valve rubber seal for cracks, wear or deterioration prior to use. A damaged rubber seal can cause a gas leak, possibly resulting in an explosion, fire or severe bodily harm. Do not use a LP gas cylinder with a damaged rubber seal.
2. Check that the grill's burner control knobs are "OFF".
3. Check that the cylinder valve is closed by turning knob clockwise.
4. Position the LP gas cylinder into the grill cabinet and secure with the tank screw.
5. Remove the protective plastic cap from cylinder valve.
6. Check that the hose does not contain kinks, and ensure that the supply hose does not come in contact with any sharp edges.

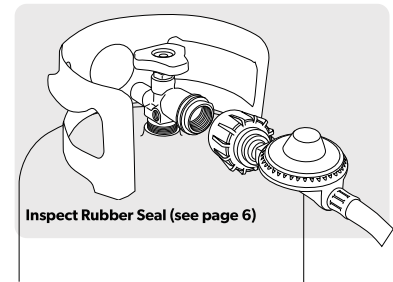

⚠ WARNING

Ensure that the supply hose does not come in contact with the heat shield above.

7. Connect the Type 1 regulator coupling to the LP gas cylinder valve, turning clockwise. Hold the regulator in a straight line with the LP cylinder when connecting. Take care not to cross thread. Hand-tighten only.
8. Leak check all fittings before lighting your grill. See section on "Leak Testing" in this manual.

NOTE: To remove regulator from LP gas cylinder, turn off the valve and rotate large coupling nut counter-clockwise.

REGULATOR RESET PROCEDURE

If you are experiencing any of the following performance issues, you may have activated the flow limiting feature in your regulator:

- Burners not getting hot enough.
- Low or incomplete burner flames.
- Low gas pressure.
- Difficulty lighting all burners or burners not staying lit.

BEFORE DISCONNECTING THE LP GAS CYLINDER:

1. With all control knobs in the "OFF" position and the LP gas cylinder shut-off valve in the "OFF" position, open the grill lid.
2. Disconnect the regulator from the LP gas cylinder.
3. Turn all control knobs to the "HI" position, and let stand for 1-3 minutes, allowing all excess gas in the gas manifold to dissipate.
4. Turn all control knobs back to the "OFF" position.
5. With the grill lid still OPEN, reconnect the regulator to the LP gas cylinder. Do not cross thread the connection. Hand-tighten only.
6. Check all connections to ensure that a positive seal has been made.
7. Slowly open the LP gas cylinder shut-off valve.
8. Wait approximately 30 seconds for the regulator pressure to stabilize.

NOTE: If the LP gas cylinder is opened too quickly, the flow limiting device in the regulator will activate, limiting the flow of gas from the LP gas cylinder.

9. Turn the first control knob to the "HI" position.
10. Press the electronic ignition button, or use a match and the match holder, or a grill lighter to ignite the burner.

NOTE: Avoid activating the flow limiting feature in the regulator by following the proper lighting and shutdown procedures and performing a complete leak test and safety check to ensure that there are no leaks in the system.

WARNING

Never use your grill without leak testing all gas connections, hoses and LP gas cylinder.

DANGER

To prevent fire or explosion hazard:

- DO NOT smoke or permit ignition sources in the area while conducting a leak test.
- Perform test OUTDOORS in a well ventilated area that is protected from the wind.
- Never perform a leak test with a match or open flame.
- Never perform a leak test while the grill is in use or while grill is still hot.

LEAK TEST PROCEDURE

WHEN TO PERFORM A LEAK TEST:

- After assembling your grill and before lighting for the first time, even if purchased fully assembled.
- Every time LP gas cylinder is refilled, exchanged or if any of the gas components are disconnected or replaced.
- Any time your grill has been moved.
- At least once per year or if your grill has not been used for more than 60 days.

CHECKING FOR LEAKS:

1. Create a mixture of 50% water and 50% liquid dishwashing soap.
2. Open lid.

NOTE: The leak test must be performed in an area that has adequate lighting in order to see if bubbles are developing and not in a windy or noisy area so larger leaks can be detected by smell or sound.

3. Ensure all control knobs are set to "OFF".
4. Brush or spray soapy water solution onto all connections shown.
5. Slowly open LP gas cylinder shut-off valve by turning the hand wheel counter clockwise.
6. Check each location listed (A–J) for growing bubbles, which indicates a leak. Large leaks may not be detected by bubbles but should produce a rushing sound or gas smell.
7. Turn off gas supply at LP gas cylinder valve.

⚠ WARNING

If you hear a rushing sound or smell gas, turn gas off. Tighten any leaking connections. If leak is detected at connection nut and tightening does not stop leak, reinspect LP gas cylinder rubber seal.

8. Tighten any leaking connections. If a leak is detected at connection nut and tightening does not stop leak, reinspect LP gas cylinder rubber seal (see page 6).
9. Repeat soapy water test until no leaks are detected.
10. Turn off gas supply at LP gas cylinder valve until you are ready to use your grill.
11. Wash off soapy residue with cold water and towel dry.
12. Wait 5 minutes to allow all gas to evacuate area before lighting grill.

⚠ WARNING

DO NOT use grill if leaks cannot be stopped. Contact customer hotline at 1-877-288-8099.

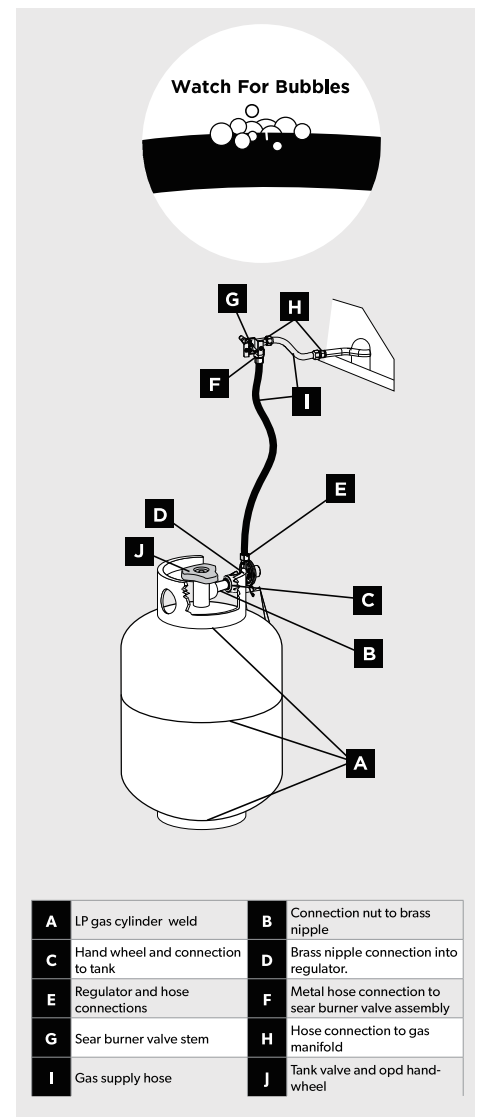

LP CYLINDER REMOVAL, TRANSPORT AND STORAGE

BEFORE DISCONNECTING THE LP CYLINDER:

1. Turn "OFF" all control knobs and the LP gas cylinder valve.
 2. Turn coupling nut counter-clockwise by hand only - do not use tools to disconnect. Remove LP gas cylinder from inside cabinet.
 3. Install safety cap onto LP gas cylinder valve. Always use cap supplied with LP cylinder valve.
- **Failure to use safety cap as directed may result in serious personal injury and/or property damage.**

⚠ WARNING

When transporting and storing the cylinder, make sure it is in an upright position and not on its side. Do not smoke around cylinder, especially when transporting in a vehicle.

LP GAS CYLINDER FILLING

- Use only licensed and experienced dealers.
- **Ensure that the dealer checks and tests the LP gas cylinder for leaks after filling.**
- LP gas cylinder dealer must purge new cylinder before filling.
- Dealer should **NEVER** fill LP gas cylinder more than 80% of LP gas cylinder volume. Volume of propane in LP gas cylinder will vary by temperature.
- Do not release liquid propane LP gas cylinder into the atmosphere. This is a hazardous practice.
- To remove gas from LP cylinder, contact an LP gas cylinder dealer or call a local fire department for assistance.

⚠ WARNING

If the above instructions are not completely adhered to, it could cause a fire/explosion, resulting in death or serious injury, or property damage.

⚠ CAUTION

A frosty regulator indicates gas overfill. Immediately close LP gas cylinder valve and call local LP gas cylinder dealer for assistance.

⚠ DANGER

Property damage, bodily harm, severe burns, and death could result from failure to follow these safety steps. These steps should be performed after the grill has been assembled and prior to each use. **DO NOT** operate this grill until you have read and understand **ALL** of the warnings and instructions in this manual.

ELECTRICAL SAFETY

Electrical equipment provided with the outdoor cooking gas appliance shall have the following in the instructions:

- a) To protect against electric shock, do not immerse cord or plugs in water or other liquid;
- b) Unplug from the outlet when not in use and before cleaning. Allow to cool before putting on or taking off parts
- c) Do not operate any outdoor cooking gas appliance with a damaged cord, plug, or after the appliance malfunctions or has been damaged in any manner. Contact the manufacturer for repair;
- d) Do not let the cord hang over the edge of a table or touch hot surfaces)
- e) Do not use an outdoor cooking gas appliance for purposes other than intended
- f) When connecting, first connect plug to the outdoor cooking gas appliance then plug appliance into the outlet
- g) Use only a Ground Fault Interrupter (GFI) protected circuit with this outdoor cooking gas appliance

⚠ WARNING

Keep any electrical supply cord and the fuel supply hose away from any heated surfaces.

⚠ WARNING

Electrical Grounding Instructions This outdoor cooking gas appliance is equipped with a three-prong (grounding) plug for your protection against shock hazard and should be plugged directly into a properly grounded three-prong receptacle. Do not cut or remove the grounding prong from this plug.

LIGHTING INSTRUCTIONS

GAS GRILL & Griddle Burner CONTROL PANEL

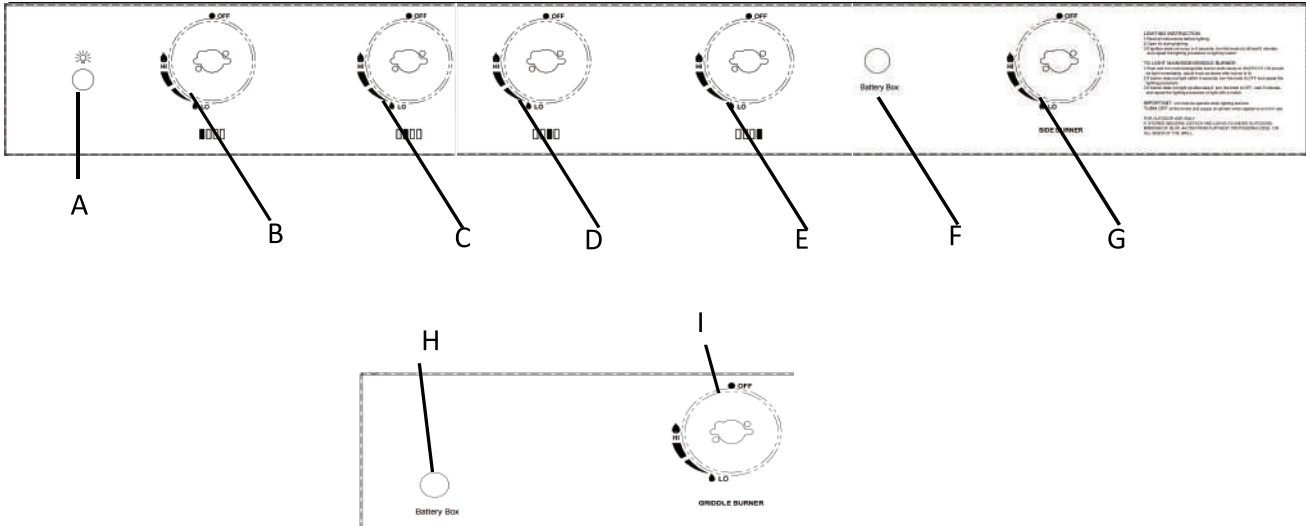

A-- Gas Grill Knob Light Switch

B~E-- Gas Grill Main Burner Knobs

F-- Battery (for Ignition) Box

G-- Gas Grill Side Burner Knob

H-- Griddle Burner Knob Light Switch

I-- Griddle Burner Knob

LIGHTING THE MAIN BURNERS/ Griddle Burner

1. Open the lid before attempting to light the burners.
2. Make sure all control knobs and the LP gas cylinder shut-off valve are "OFF."
3. SLOWLY turn the LP gas cylinder shut-off valve counter-clockwise to open. Wait 30 seconds for the pressure to stabilize.
4. Push in and turn control knobs #1, #3 and #5 counter-clockwise to "HI" . Press the igniter for 3 to 5 seconds. You will hear a clicking sound.
5. If ignition does NOT occur within 5 seconds, turn control knobs to "OFF," wait 5 minutes to allow gas to dissipate, and repeat the lighting procedure.
6. If the burner does not ignite, see the "Match Lighting the Main Burners" section.

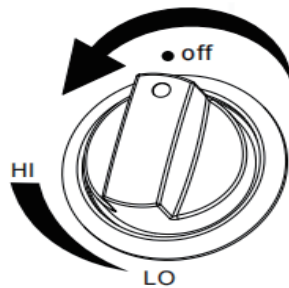

⚠ ATTENTION

To change the preset setting, you will need to push in and turn the thermostatic control knob each time to set the desired temperature. When the knob is released, the temperature is locked.

⚠ IMPORTANT

When using the preset temperature, burner #2 and burner #4 will not function. Burners must remain in the "OFF" position.

LIGHTING INSTRUCTIONS

WHEN SWITCHING FROM THERMOSTATIC CONTROL TO BBQ MODE

⚠ ATTENTION

Burner #2 and burner #4 include a thermocouple and safety shut-off valve that will restrict the use of both burners when the thermostatic control knob has been turned on.

1. Push in and turn the thermostatic control knob, clockwise to BBQ mode.
2. To light burner #2 and #4, push in and turn both knobs, counter-clockwise to "HI" and hold for 5-10 seconds, allowing the thermocouple to heat up, before releasing the knobs.

MATCH LIGHTING THE MAIN BURNER:

1. Open the lid before lighting the burner.
2. Make sure all control knobs and the LP gas cylinder shut-off valve are "OFF".
3. SLOWLY, turn the LP gas cylinder shut-off valve counter-clockwise to open. Wait 30 seconds for pressure to stabilize.
4. Place a paper match in the end of the match lighting tool. Strike match and place through the cooking grate and opening on the heat tent approximately 1/2" (1 to 2 cm) from the burner to be lit.
5. Push in and turn burner control knob #1 to "HI". The burner should light within 5 seconds.
6. If burner does not light, turn control knob to "OFF" and wait 5 minutes for gas to dissipate. Repeat the lighting procedure.
7. Once lit, light remaining burners by following steps 4-6.
8. If burner does not light within first few attempts of match lighting, there may be a problem with the gas supply.
9. Turn off gas at the burner and LP gas cylinder. DO NOT attempt to operate grill until the problem is found and corrected.

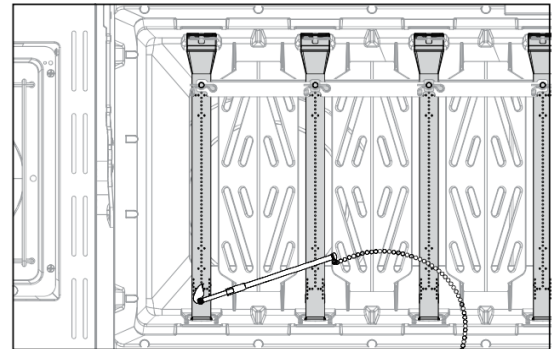

NOTE: If the burner does not light or flame goes out, retry these steps. For any issues related to low flames, see the "Troubleshooting" section of this manual on pages 24-25.

SHUT DOWN PROCEDURE

1. Push in and turn each control knob clockwise to the "OFF" position.
2. Turn LP gas cylinder shut-off valve clockwise to close.

⚠ CAUTION

The cylinder valve should always be in the "OFF" or closed position when grill is not in use.

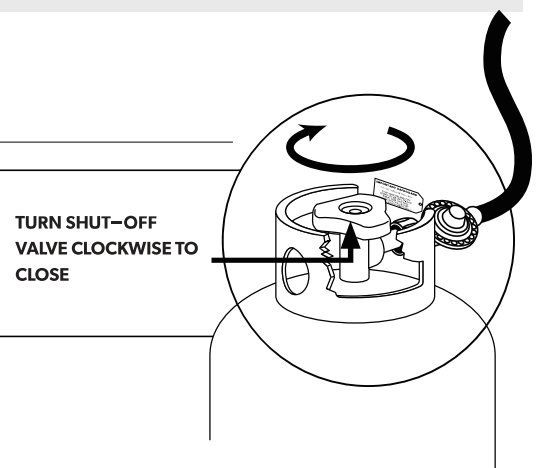

START GRILLING

⚠ WARNING:

Read and follow all warnings and instructions contained in the preceding sections of this manual.

- DO NOT cover cooking grates or other components with aluminum foil, as this blocks ventilation and damage to grill or result in personal injury.
- DO NOT leave your grill unattended while it is "ON" or in use.
- DO NOT move grill when it is hot, or in use.
- DO NOT use water on a grease fire. If safe to do so, close the grill lid to extinguish the fire or smother with dirt, sand or baking soda. If closing the lid to extinguish the fire is not possible, use a fire extinguisher or smother the fire with dirt, sand, or baking soda.
- Never cook on the grill without the grease cup/tray in place.

BREAKING IN YOUR GRILL:

- In the process of manufacturing and preserving the components of your grill, oil residue may be present on burners and cooking surfaces.
- Before cooking for the first time you should preheat for 15 minutes on "HI" to burn off these residual oils.

PREHEATING WHEN USING THE THERMOSTATIC CONTROL SYSTEM

Much like your grill and indoor oven, preheating is required to ready the grill for cooking.

- Do not preheat on high temperatures. Preheating on higher temperatures will require an extended period of time for the cooking grates to cool down and reach the target temperature.
- Always preheat at the target temperature for 10-15 minutes before positioning food on the cooking grates.
- In cold and windy conditions, longer preheat times may be required. Ensure your grill is positioned away from direct wind and other elements.

ROTISSERIE COOKING:

⚠ WARNING:

- To avoid damage to the warming rack, remove from grill when using the rotisserie burner.
- Remove the rotisserie burner when using the side burner
- Do not use the main burners when the rotisserie burner is in use.
- Do not lean over the grill.

USING RUBS AND SAUCES

Always apply dry rubs to meat in advance of cooking and let it sit, covered at room temperature for a minimum of 20 minutes. Dry rubs contribute to the delicious, bold flavors and crunchy "bark" or crust that builds up during low and slow cooking.

- Always apply sauces towards the end of the cook to create a caramelized crust. Applying sauce too early can cause the sauce to burn or dry out leaving a bitter burnt char on the surface.

START GRILLING

GRILL COOKING TIPS:



WARNING

TO ENSURE THAT IT IS SAFE TO EAT, FOOD MUST BE COOKED TO THE MINIMUM INTERNAL TEMPERATURES LISTED IN THE TABLE BELOW.



USDA SAFE MINIMUM INTERNAL TEMPERATURES

Fish	145° F (63° C)
Pork	160° F (71° C)
Egg Dishes	160° F (71° C)
Steaks and Roasts of Beef, Veal or Lamb	145° F (63° C)
Ground Beef, Veal or Lamb	160° F (71° C)
Whole Poultry (Turkey, Chicken, Duck, etc.)	165° F (74° C)
Ground or Pieces Poultry (Chicken Breast, etc.)	165° F (74° C)

USDA Food Safety and Inspection Service



WARNING: TO ENSURE THAT IT IS SAFE TO EAT, FOOD MUST BE COOKED TO THE MINIMUM INTERNAL TEMPERATURES LISTED IN THE TABLE ABOVE. USDA SAFE MINIMUM INTERNAL TEMPERATURES FISH 145° F (63° C), PORK 160° F (71° C), EGG DISHES 160° F (71° C), STEAKS AND ROASTS OF BEEF, VEAL OR LAMB 145° F (63° C), GROUND BEEF, VEAL OR LAMB 160° F (71° C), WHOLE POULTRY (TURKEY, CHICKEN, DUCK, ETC.) 165° F (74° C), GROUND OR PIECES POULTRY (CHICKEN BREAST, ETC.) 165° F (74° C).

PREVENTION

CONTROLLING FLARE-UPS/GREASE FIRES:

- Flare-ups are a common occurrence when cooking meats on a gas grill. Use caution when opening lid, as sudden flare-ups may occur. Excessive flare-ups can overcook your food and create a dangerous situation for you and your grill. Excessive flare-ups result from the build-up of grease in your grill. If this should occur, **DO NOT** pour water onto the flames. This can cause grease to splatter and may result in serious burns or bodily harm.
- If safe to do so, remove food from grill surface, close the lid, shut off all grill control knobs, close LP gas cylinder valve and allow the fire to burn-out.
- If grease fire does not quickly burn out, or if the fire is growing/spreading: Use fire extinguisher or smother the fire with baking soda.

TO MINIMIZE FLARE-UPS:

- Trim excess fat from meats prior to cooking.
- Cook meats with high fat contents (chicken or pork) on "LOW" settings or indirectly.
- Ensure that your grill is on level ground and grease is allowed to evacuate grill the drain hole in the bottom and into the grease cup/tray.
- Clean the grill frequently to minimize grease build-up.

PROPER BURNER FLAME PATTERN

The burner flame pattern is the key indicator of proper or improper function within the cook system. When the burners are performing correctly, you will see a specific flame pattern. All burner ports should be 2.5 cm/ 1" flame on "HI" with orange tips, light blue center, with a darker blue flame at the base of the burner port. Refer to the Troubleshooting section on pages 19-20 if you experience any of the following issues:

- Large, unruly, or irregular orange burner flames.
- The smell of gas in conjunction with irregular flames.
- Low temperatures or uneven heat.

⚠ ATTENTION:

After lighting, ensure the burner is lit correctly and the flame pattern is as expected. If the flame pattern is not normal, check the troubleshooting guide for solutions.

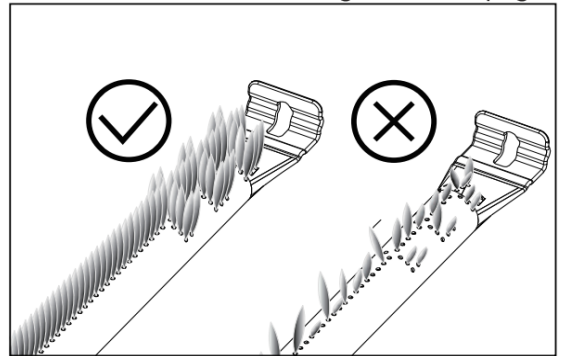

BLOCKED BURNER VENTURI

Blockages in the burner venturi caused by spiders, insects or nests can cause a FLASHBACK FIRE. A flashback fire occurs when a blockage in the venturi tubes caused by spiders, insects and nests blocks the flow of gas, forcing it back towards the control panel and control knob. The ignited gas, if not detected, can cause a fire to burn in this area.

IF YOU EXPERIENCE ANY OF THE CHARACTERISTICS OF A FLASHBACK FIRE. CLOSE THE LP GAS CYLINDER SHUT-OFF IMMEDIATELY. FOLLOW THE BURNER CLEANING PROCEDURE OUTLINED IN THE MAINTENANCE SECTION OF THIS MANUAL.

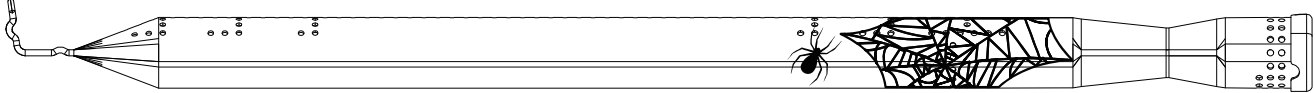

CHARACTERISTICS OF A FLASHBACK FIRE

- A fire burning outside of the firebox, usually visible behind or under the control panel.
- Hot or melting control knobs.
- Large yellow, unruly flames accompanied by the smell of gas.
- Burners not lighting correctly, or partially lighting.

⚠ WARNING

At first sight of yellow, unruly flames, poorly lit burners accompanied by the smell of gas, shut down your grill, and perform burner cleaning maintenance, outlined in the maintenance section of this manual, page 22.

MAINTENANCE

PROPER CARE & MAINTENANCE

⚠ ATTENTION:

If you are experiencing any of the following performance or safety issues: 1) grill not reaching temperature potential, 2) yellow burner flames, 3) the smell gas, 4) popping noises, 5) delayed burner ignition, 6) uneven heat, 7) flash fires, or 8) grease fires, **TURN OFF YOUR GRILL** immediately and perform the following maintenance regime. Perform these steps when your grill is off and cool. A thorough cleaning is recommended at least twice a year, or more if your grill is used consistently.

⚠ CLEANING THE FIREBOX ⚠

EXCESSIVE BUILD-UP inside the firebox can **LEAD TO GREASE FIRES AND OVERHEATING.**

1. Use a plastic scraper to scrape debris off the interior surfaces of the firebox, and into the grease tray liner. **IF A MORE THOROUGH CLEANING IS REQUIRED:**
2. For stubborn build-up, use a grill degreaser to loosen up debris and then repeat step 1.

⚠ ATTENTION: CLEANING THE GREASE COLLECTION TRAY AND GREASE CUP

The grease management system consists of an angled pull-out grease collection tray and a grease cup. These components were designed to be easily removed, cleaned and replaced. Remove the pull-out grease collection tray by pulling the tray out of the cabinet. Remove excess grease with a plastic scraper or if a deeper clean is required, clean with a garden hose, soap and water. Remove the grease cup and liner and scrape grease into the garbage. If a deeper clean is required, wash with soap and water or replace the disposable grease cup liner.

CLEANING PORCELAIN CAST IRON COOKING GRATES (IF APPLICABLE)

During preheat, brush cooking grates with a grill brush to remove debris.

IF A MORE THOROUGH CLEANING IS REQUIRED:

1. Wash cooking grates with soap and water only.
2. Rinse and dry thoroughly with a towel. If cleaning on a very hot day, allow grates to dry in the sun.

⚠ CAUTION:

Always handle Porcelain-Coated Cast Iron grates with care to avoid damaging the porcelain enamel finish.

CLEANING THE HEAT PLATES

1. Remove heat plates.
2. Holding your heat plate over a large garbage receptacle, use a plastic paint scraper or a grill brush to remove debris **IF A MORE THOROUGH CLEANING IS REQUIRED:**
3. Clean away all remaining debris with mild soap and warm water.
4. Dry thoroughly.
5. Re-install.

MAINTENANCE

CLEANING THE BURNERS

Keeping burners free of blockages including spiders, insects, nests and other debris that can block the burner ports is essential for safe operation.

1. Use a clean grill brush to clean the outside of the burner.
2. Remove the hitch pins used to secure the burners to the firebox. Use pliers if necessary.
3. Lift burners out slightly, exposing the burner venturi. Be careful not to damage or disconnect the electrode connector.
4. Use a pipe cleaner or flexible Venturi Brush to clean the interior of all burners. Shake any loose debris out of the burner.
5. Use a wire or paper clip to clean burner port holes. Do not use anything that can damage or enlarge port holes.
6. Use a clean soft bristle brush to clean spider/ insect screens.
7. Reinstall, ensuring that the burner orifice is placed over the gas jet correctly.

CLEANING STAINLESS STEEL COOKING GRATES (IF APPLICABLE)

The stainless-steel cooking grates are very low maintenance. Regular cleaning should include a burn-off of excess grease and brushing away debris with a grill brush.

If a more thorough cleaning is required, grates can be removed and cleaned with warm soapy water and a fine scouring pad, to avoid scratching or damage the surface. Once clean, rinse and dry thoroughly. It is possible to coat the grates with vegetable or canola oil for added protection, but this is best done when the grates are not in the firebox and using a paper towel.

CLEANING THE INSIDE OF THE LID

Over time you may notice "paint-like" peeling on the inside of the grill lid. During use, grease and smoke vapors turn into carbon deposits, which eventually begin to peel. These deposits are non-toxic but should be cleaned off to avoid flakes falling onto food.

Use a grill brush to brush off the carbon build-up from inside the lid to prevent this accumulation.

CLEANING THE EXTERIOR STAINLESS-STEEL SURFACES (IF APPLICABLE)

- Always use a non-abrasive, non-toxic stainless-steel cleaner designed for outdoor products and grills.
- Always use a micro-fiber cloth to clean in the direction of the stainless-steel grain.
- Do not use paper towels as they can scratch the stainless-steel finish.
- If you notice a film or leftover residue from your cleaner, rinse thoroughly with water and dry with a micro-fiber cloth.
- Do not allow any spills from sauces to remain on stainless steel parts.
- Always wipe surfaces immediately following cooking.

CLEANING THE WINDOW

The window can become dirty with build-up of grease and smoke as well as darken over time.

- To remove baked on grease and smoke, combine 1/2 cup of baking soda in a bowl with enough water to form a paste.
- Before applying the paste to the window, wipe off any loose grease and debris with a soft microfiber cloth. Spread the paste on the inside of the grill window and let stand for 15-20 minutes.
- Wet a clean microfiber cloth and wipe the paste away. Repeat steps as needed.
- Use a dry microfiber cloth to buff out any streaks on the glass.

DO NOT USE ANY ABRASIVE CLEANSER OR METAL SCOURING PAD AS THESE WILL SCRATCH THE WINDOW SURFACE

MAINTENANCE

CLEANING THE EXTERIOR PAINTED, PORCELAIN ENAMEL SURFACES (IF APPLICABLE)

1. Clean painted and porcelain-coated surfaces with warm soapy water.
2. After wiping down all surfaces, rinse thoroughly with water.
3. Dry with a soft microfiber cloth.

DO NOT USE ANY CHEMICAL CLEANERS ON PAINTED SURFACES AS THEY COULD STRIP THE PAINT AND PERMANENTLY DAMAGE THE SURFACE, LEAVING IT UNPROTECTED.

Cleaning the Outside of Grills that are in Unique Environments if your grill is subject to a particularly harsh environment, you will want to clean the outside more often. Acid rain, pool chemicals, and salt water can cause surface rusting to appear. Wipe down the outside of your grill with warm soapy water. Follow up with a rinse and thorough drying. Additionally, you may want to apply a stainless-steel cleaner weekly to prevent surface rust.

STORING YOUR GRILL

Before storing your grill ensure that cylinder valve is fully closed.

- Clean all surfaces. Lightly coat burners with cooking oil to prevent excess rusting.
- If storing grill indoors, disconnect LP gas cylinder and leave LP gas cylinder OUTDOORS.
- Place dust cap on cylinder valve outlet whenever the cylinder is not in use.
- Check and clean burner prior to use after storing, at the beginning of grilling season or after a period of not being used. Spiders and insects like to build nests in burner tubes (especially during colder months). Blocked burner tubes can prevent gas flow to burners and could result in a burner tube fire or fire beneath grill.
- If storing grill outdoors, cover grill with a grill cover for protection from the weather.
- Remove and clean all components. Season cooking grates with vegetable shortening and wrap in a towel before storing.
- If storing for a prolonged period, remove the igniter battery to avoid corrosion.

⚠ WARNING:

- Make sure that LP gas cylinder valve is closed and burner knobs are in the "OFF" position.
- DO NOT store a spare LP gas cylinder (filled or empty) under or near the grill.
- Never store flammable liquids or spray canisters under or near the grill.
- If the outdoor cooking gas appliance is not in use, the gas must be turned off at the LP gas supply cylinder.
- LP gas cylinders must not be stored in a building or enclosure, including garages and sheds.
- LP gas cylinders must be kept out of reach of children.

⚠ Battery care, use and disposal ⚠

DO start by positioning a brand new battery in your electronic ignition module.
DO remove the battery from the electronic ignition module during storage periods.
DO recycle or dispose of batteries properly, as per the requirements of your local municipality.

DO NOT submerge the electronic ignition module in water.
DO NOT leave the batteries where a child or pet could play with or swallow them.

⚠ WARNING:

HEED THE WARNINGS IN THIS MANUAL. ALWAYS PERFORM A LEAK TEST, EVERY TIME YOU REFILL OR CHANGE YOUR LP GAS CYLINDER.
NEVER LEAVE YOUR LP GAS CYLINDER OPEN WHILE NOT IN USE. NEVER LEAVE THE CONTROL KNOBS OPEN WHILE NOT IN USE. ALWAYS OPEN YOUR GRILL LID BEFORE ATTEMPTING TO LIGHT YOUR GRILL .

TROUBLE SHOOTING

PROBLEM	IDENTIFYING THE CAUSE:
Burners will not light (with igniter or match)	Positive connection has not been made between the LP gas cylinder and the regulator.
	Low or out of propane.
	Gas supply valve is turned off.
	Burners are not properly seated over valve orifices.
	Flow limiting device in regulator has been activated. Follow reset instructions on page 8.
Burners will not light with the igniter, but can match-light (no spark)	Ignition module battery needs to be replaced. Replace the battery. Ensure positive side out towards battery cap.
	Loose ignition button lead wires - check lead wires on the back of the ignition button. Push in until you feel a click
	Loose wires at electronic ignition module (see inside cabinet). Push in until you feel a click.
Fire at control knob /control panel flashback fire	Faulty electronic ignition module. Contact customer support to order a replacement.
	Burner and/or burner tubes have a blockage, forcing flames back towards the user. Burners must be removed and cleaned to resolve this issue. Follow the steps on page 15 .
Yellow smokey flames/ gas odor can be smelled	Burner is improperly seated over gas jet. The gas valve must sit inside of the burner venturi. Disassemble the burner and fix the assembly.
	Burner and/or burner venturi is obstructed and needs to be cleaned. Burners must be removed and cleaned, to resolve this issue. Follow the steps on page 15 .
Flame blows out on LOW	Possible spider web or other debris.
	Flow limiting device in regulator has been activated, either due to a leak or improper lighting. You must conduct a leak test (page 9) and reset the regulator (page 8).
	Low or out of propane.
	High wind condition. Adjust your grill to shield from wind.
Preset temperatures are unable to reach higher temperature levels	Burner is improperly seated on gas jet. The gas valve must sit inside of the burner venturi. Disassemble the burner and fix the assembly.
	Ensure that the lighting burner control knobs are set to "HI" when using the thermostatic control system.
Low heat	Flow limiting device in regulator has been tripped, restricting the flow of gas to the burners. You must perform a regulator reset (page 8) and follow proper lighting procedure (pages 11-12) to avoid this in the future.
	Make certain the problem is isolated to only one burner. If it appears so, the burner and/or burner tubes are blocked. Burners must be removed and cleaned to resolve this issue. Follow the steps on page 15 .
	Check for a bent or kinked fuel hose.
	In colder temperatures, preheat for longer periods.
Low or incomplete flame (assuming burners and venturi tubes are free and clear of blockages)	Flow limiting device in regulator has been activated due to a leak or improper lighting. Perform a leak test (page 9) and perform a regulator reset (page 8).
Too much heat/ Excessive flare-ups	Excessive grease and build-up on heat tents, in grease cup and within firebox. Follow cleaning steps on pages 16 .
	Cooking on the HI position: Only use HI for preheating and searing. Always adjust the temperature to avoid too much heat.
	Covering more than 70% of the cooking surface may cause overheating.
	Excessive fat on meat. Always cut fat where possible to limit excess grease drippings.
Flame is noisy, low or erratic	- Is the gas supply fully turned on?: Check if the propane tank valve is fully open.
	-Is the gas supply in the propane tank low?: Check the gas level.
	-Does only one burner appear low?: Check and clean the burner if it's clogged or dirty.
	-Is the gas supply hose bent or kinked?: Straighten the gas supply hose.
	Is the flame noisy or lifting away from the burner?

Replacing light bulb







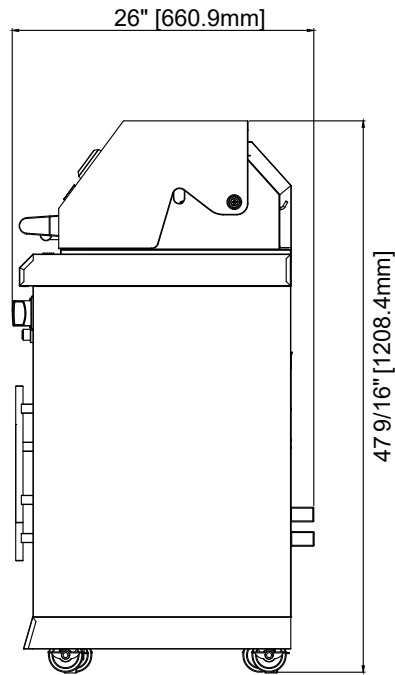
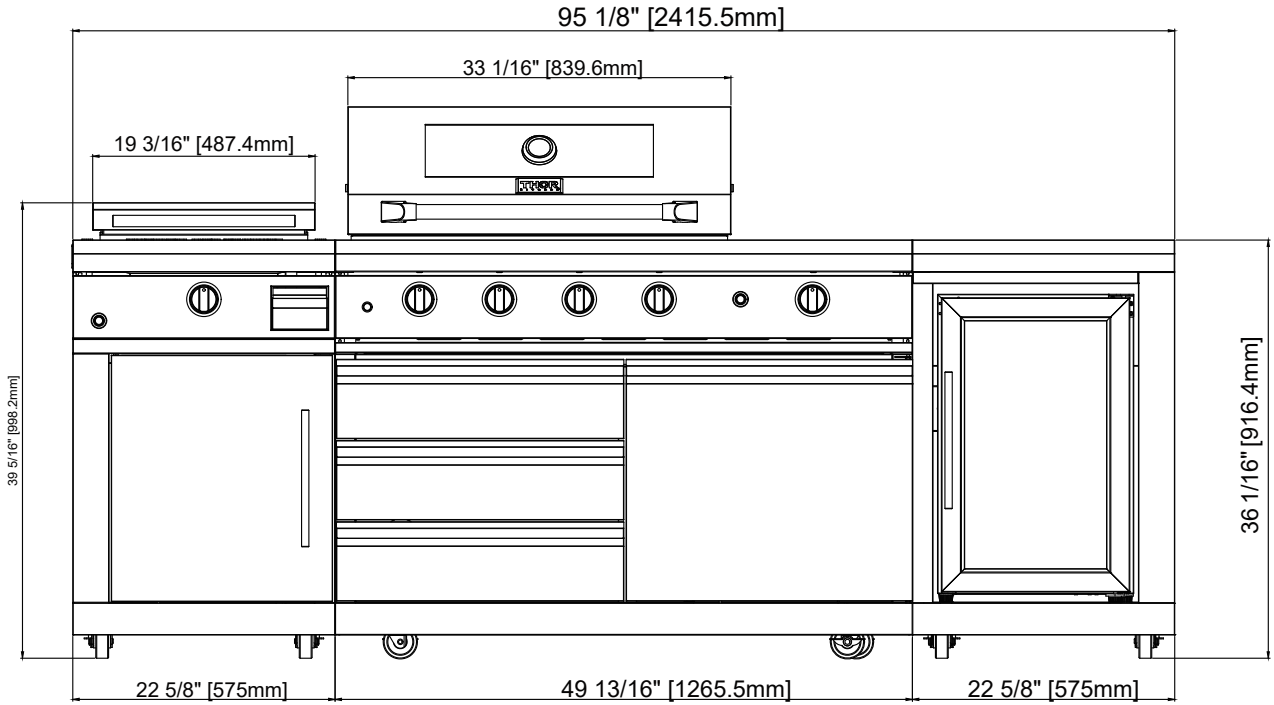

Take out the grease tray and find the connector of grill light bulb. Take out the 5 screws on the lamp cover to get access to the bulb.

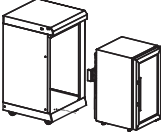
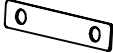

Product Dimensions



ASSEMBLY PART LIST

Key	Description	Picture	Qty
1	Gas Grill Assembly		1
2	Griddle Burner		1
3	Beverage&Cabinet		1
4	Front connecting Plate		2
5	Rear connecting Plate		2
6	Cord Holder		2
7	1/4" Screws		18 (Including 2 spare parts)
8	5/32" Screws		4
9	Rain Cover		1

ASSEMBLY INSTRUCTIONS

Step 1

The connecting cable for the knob light above Key#1 passes through the circular hole in the right side panel of Key#2

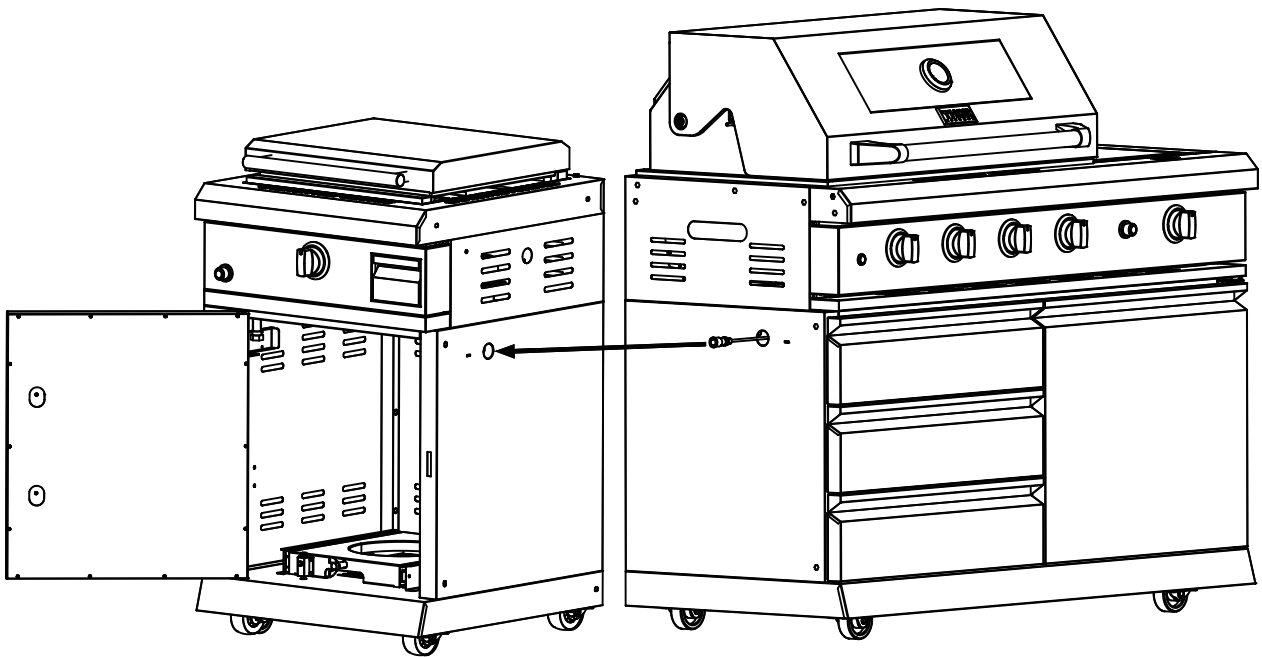

ASSEMBLY INSTRUCTIONS

Step 2

Connect light cable to the plug connector and tighten the external screws

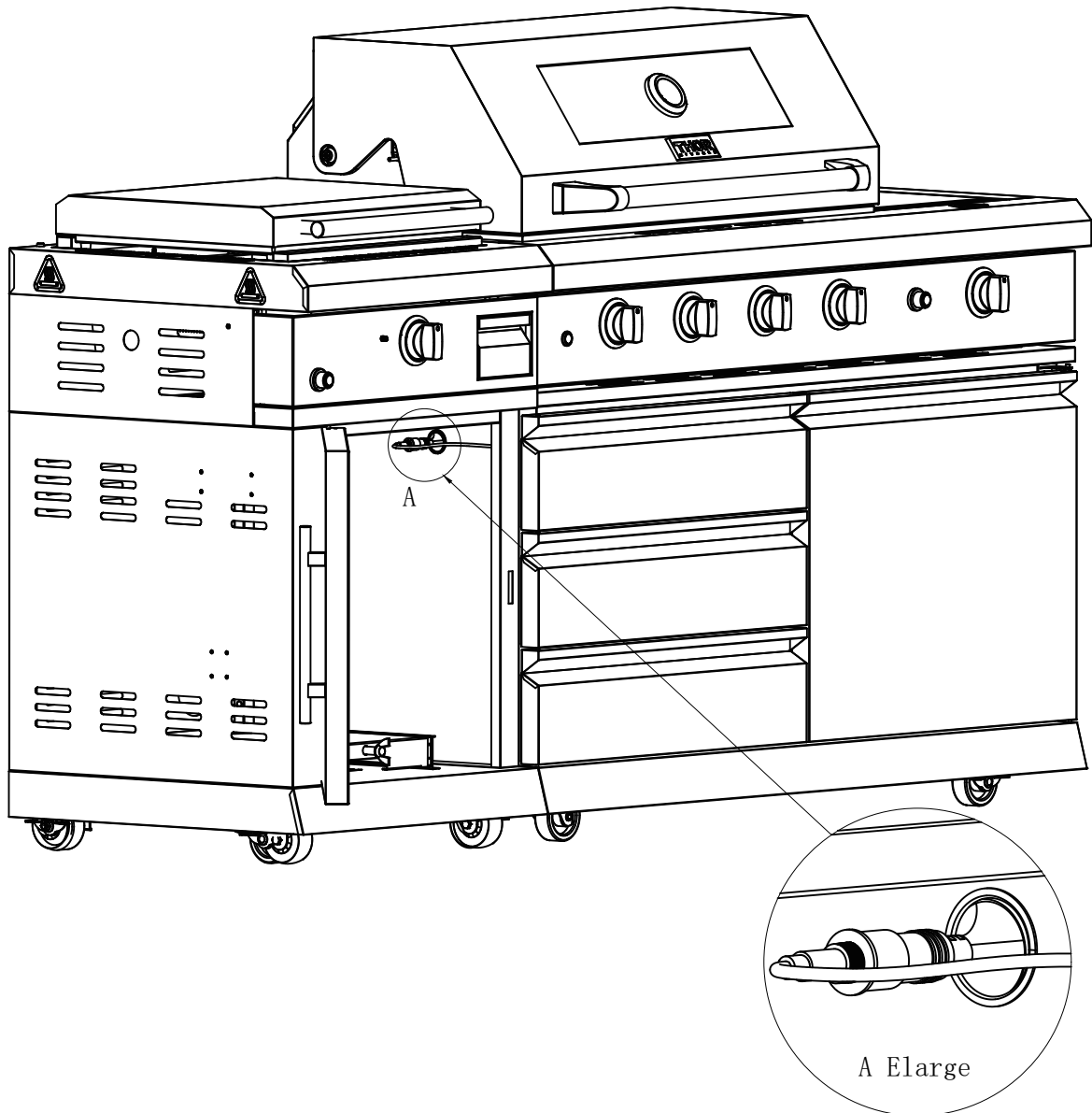

ASSEMBLY INSTRUCTIONS

Step 3

 Key#7: 2PCS

Open the door of Key#2, use 2pcs of screw fix the right side panel of Key#2 and left panel of Key#1

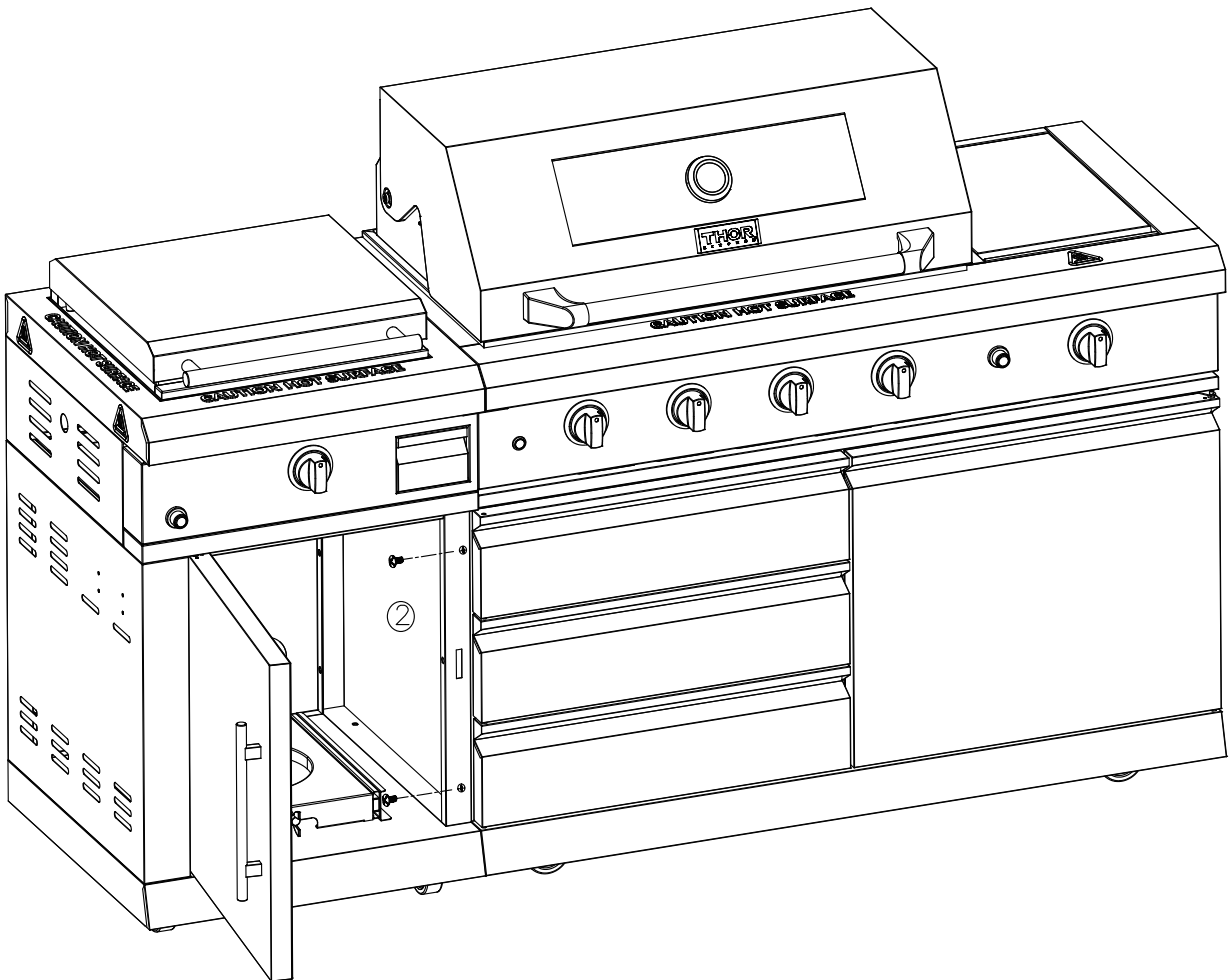

ASSEMBLY INSTRUCTIONS

Step 4

1. Unscrew the four screws on the back Key#3 with a screwdriver
2. Then remove the Beverage from the front
3. Take out the Styrofoam

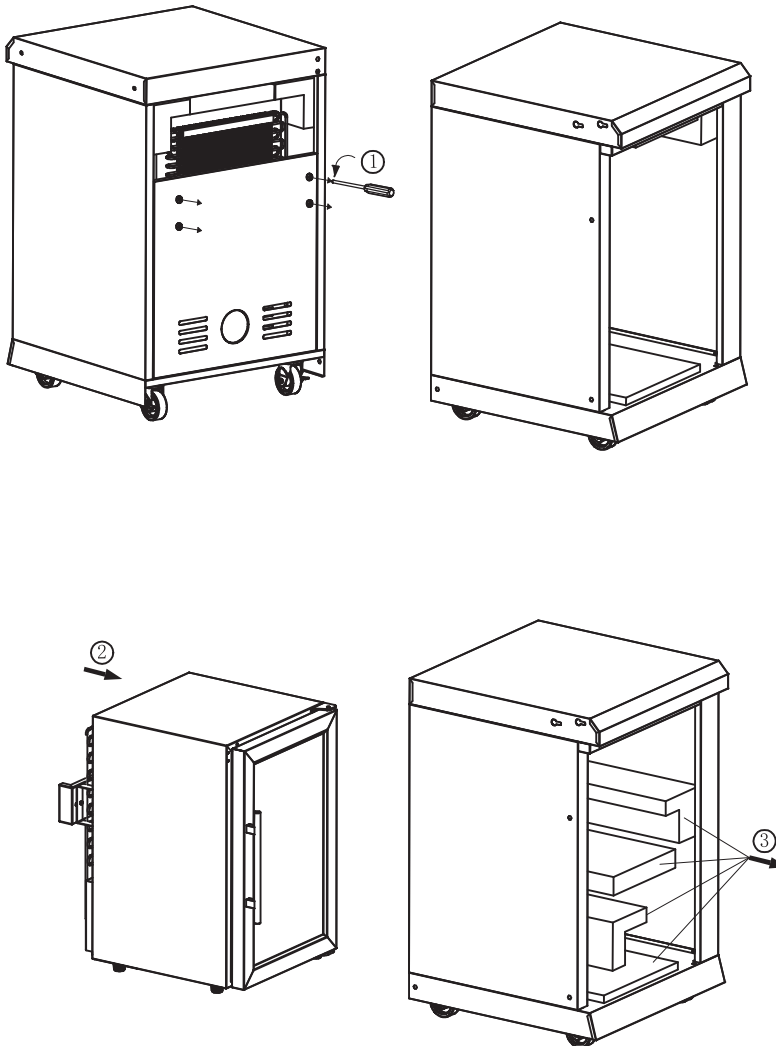

ASSEMBLY INSTRUCTIONS

Step 5

🔑 Key#7:2PCS

Open the door of Key#2, use 2pcs of screw fix the right side panel of BBQ and left panel of BBQ

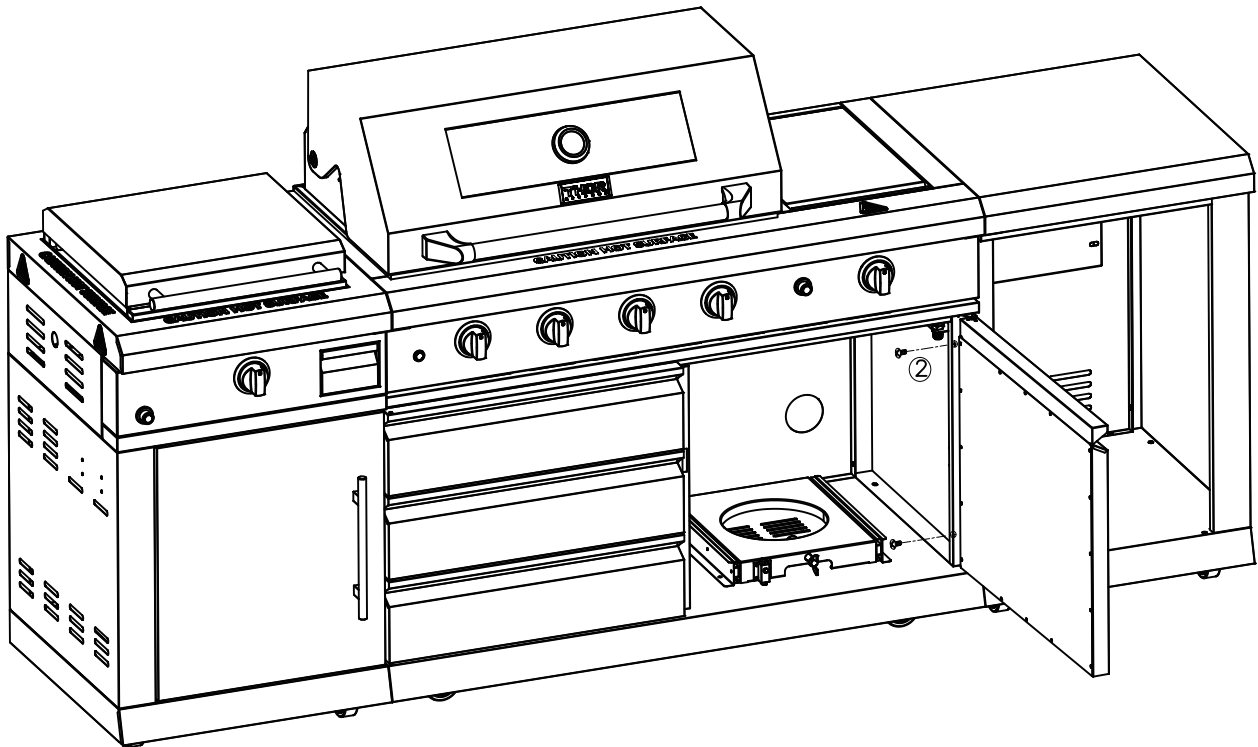

ASSEMBLY INSTRUCTIONS

Step 7

1. Open the refrigerator door and take out the foot pads
2. Install foot pads on the refrigerator
3. Put the refrigerated cabinet back into the electrical cabinet box

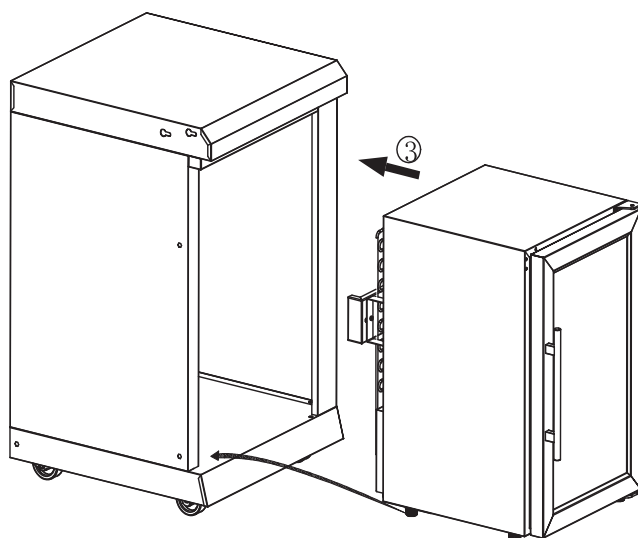
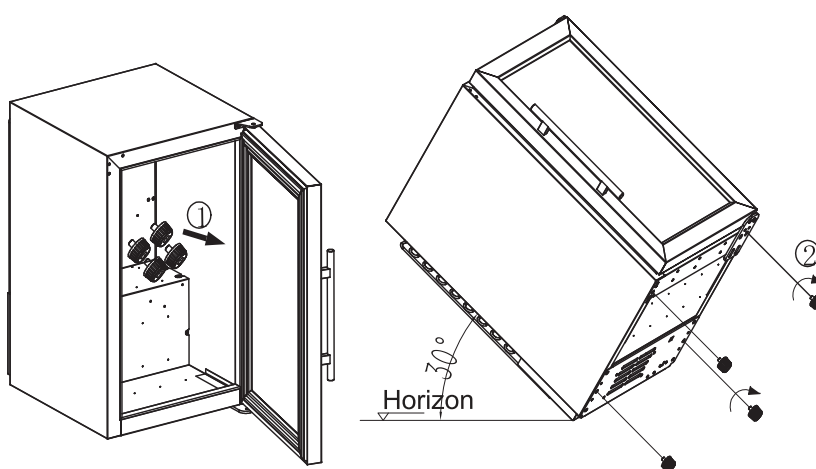

ASSEMBLY INSTRUCTIONS

Step 8



Key#7: 4PCS



Key#4: 2 PCS

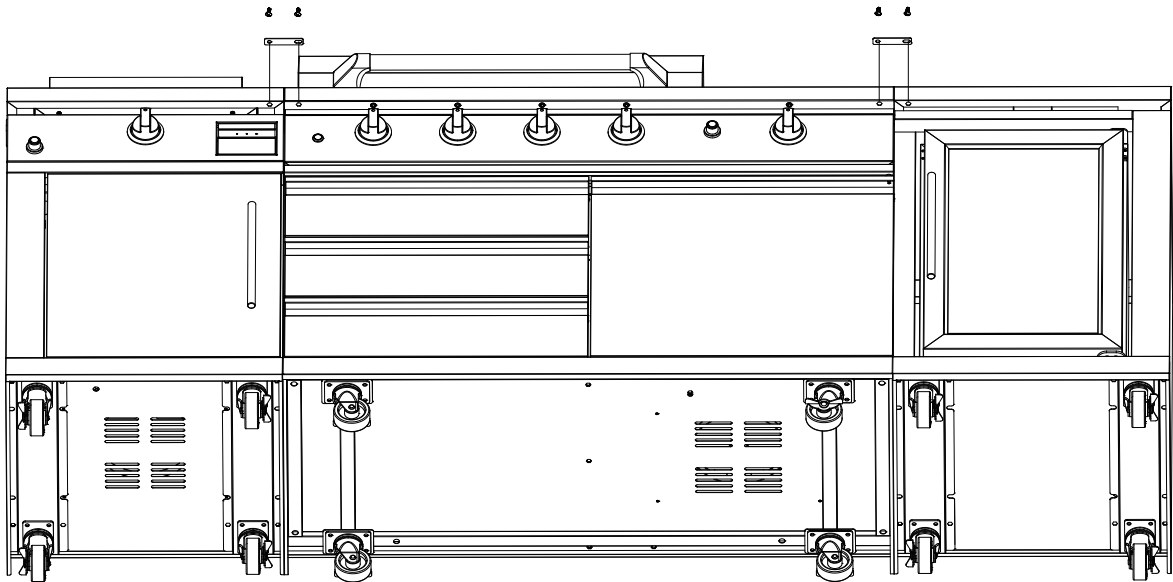

Use a screwdriver to tighten Key#7 to secure Key#4



ASSEMBLY INSTRUCTIONS

Step 9

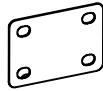
 Key#7:8PCS  Key#8:4PCS

 Key#5:2PCS  Key#6:2PCS

Use a screwdriver to tighten the screws to secure

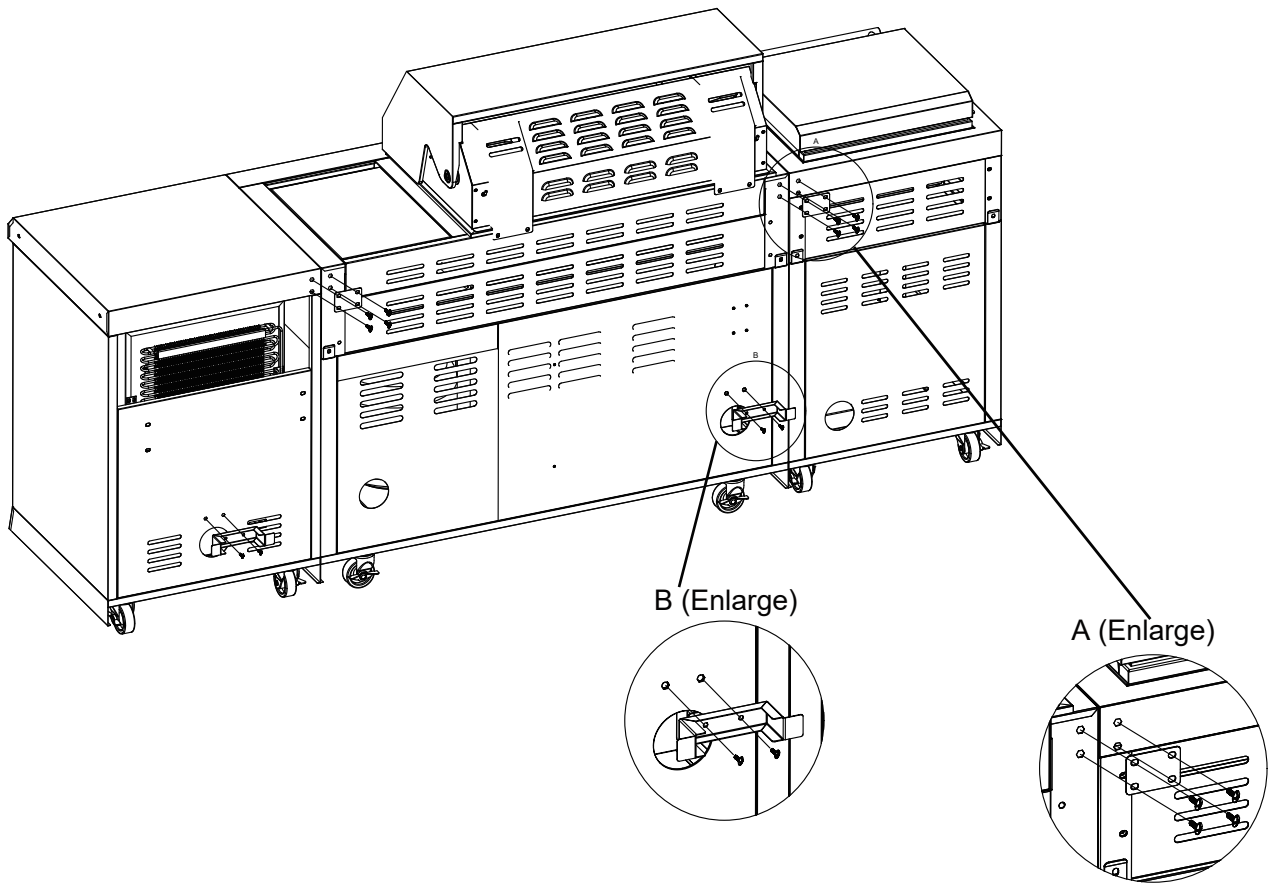

WARRANTY AND SERVICE

This product is covered by the THOR INTERNATIONAL CUSTOMER SERVICE TEAM.

Please visit: www.thorkitchen.com/service

BEFORE YOU CALL FOR SERVICE, have the following information available:

1. **Serial Number:** The serial number is located on the front of this manual and on the rating label located inside your grill cart.
2. **Model Number:** The model number is located on the front cover of this manual and on the rating label located inside your grill cart.
3. **Proof Of Purchase:** By the original owner.

Call Customer Care Hotline: 1-877-288-8099

Email Address: service@thorinternational.com

LIMITED WARRANTY:

1 Year Parts Only

For all products in the Outdoor Kitchen Suite category: In the event of a sealed system failure, the unit would be replaced with a new or refurbished model equal to or with similar features as the original product purchased by you at Thor's discretion.

CAUTION:

Some parts may contain sharp edges – Especially as noted in the manual! Wear protective gloves if necessary.
FOR RESIDENTIAL USE ONLY. DO NOT USE FOR COMMERCIAL COOKING.

WARNING:

Do not attempt to repair or alter the hose/valve/regulator for any assumed defect or for any type of retro fit or conversion. Any modifications to this assembly will void your warranty and create the risk of a gas leak and fire. Use only authorized replacement parts supplied by the manufacturer, for your model.

Company information: Guangdong Hyxion Smart Kitchen Co.,Ltd
Factory: No.1 and No.2 Haixin Road, Hongmei Town, Dongguan,Guangdong, China