

**Rubbermaid**®

# FASTTRACK®

## 7W96 – Lower Locker Assembly Steps



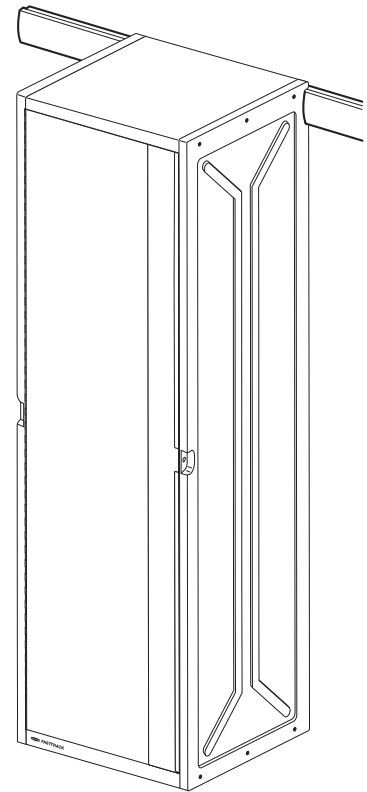
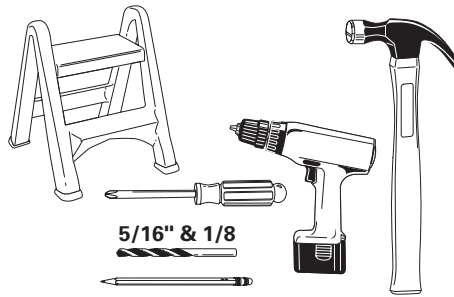

2001932

Rubbermaid Incorporated,  
Huntersville, NC U.S.A. 28078-1801  
U.S.A. 1-888-895-2110  
Canada 1-866-595-0525  
[www.rubbermaid.com](http://www.rubbermaid.com)

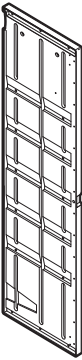
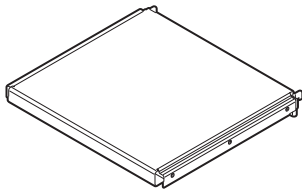
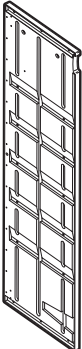
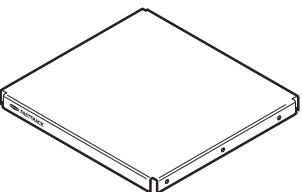
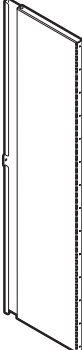
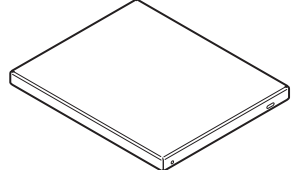
**newell**  
BRANDS

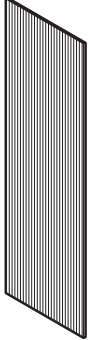

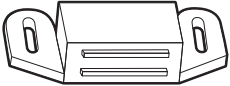
Pieces	Qty	Pieces	Qty
<b>A</b> Right Side Panel 	1	<b>D</b> Top 	1
<b>B</b> Left Side Panel 	1	<b>E</b> Bottom 	1
<b>C</b> Door 	1	<b>F</b> Shelf 	1

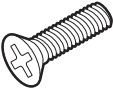
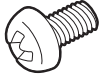
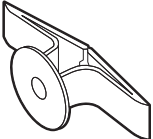
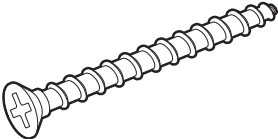
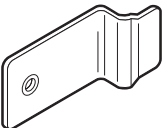
Pieces	Qty
<b>G</b> Back Panel 	1
<b>H</b> Hinge & Keeper Bracket Screws M2.9 x 19mm 	16
<b>I</b> Magnet 	2
<b>J</b> Magnet Screws #6 x 3/4" 	4
<b>K</b> Side Panel Screws #10-32 x 3/4" 	12
<b>L</b> Shelf Screws M5 x 8mm 	4
<b>M</b> Wall Anchor 	2
<b>N</b> Wall Anchor Screw #10 x 2" 	2
<b>O</b> Keeper Brackets 	2

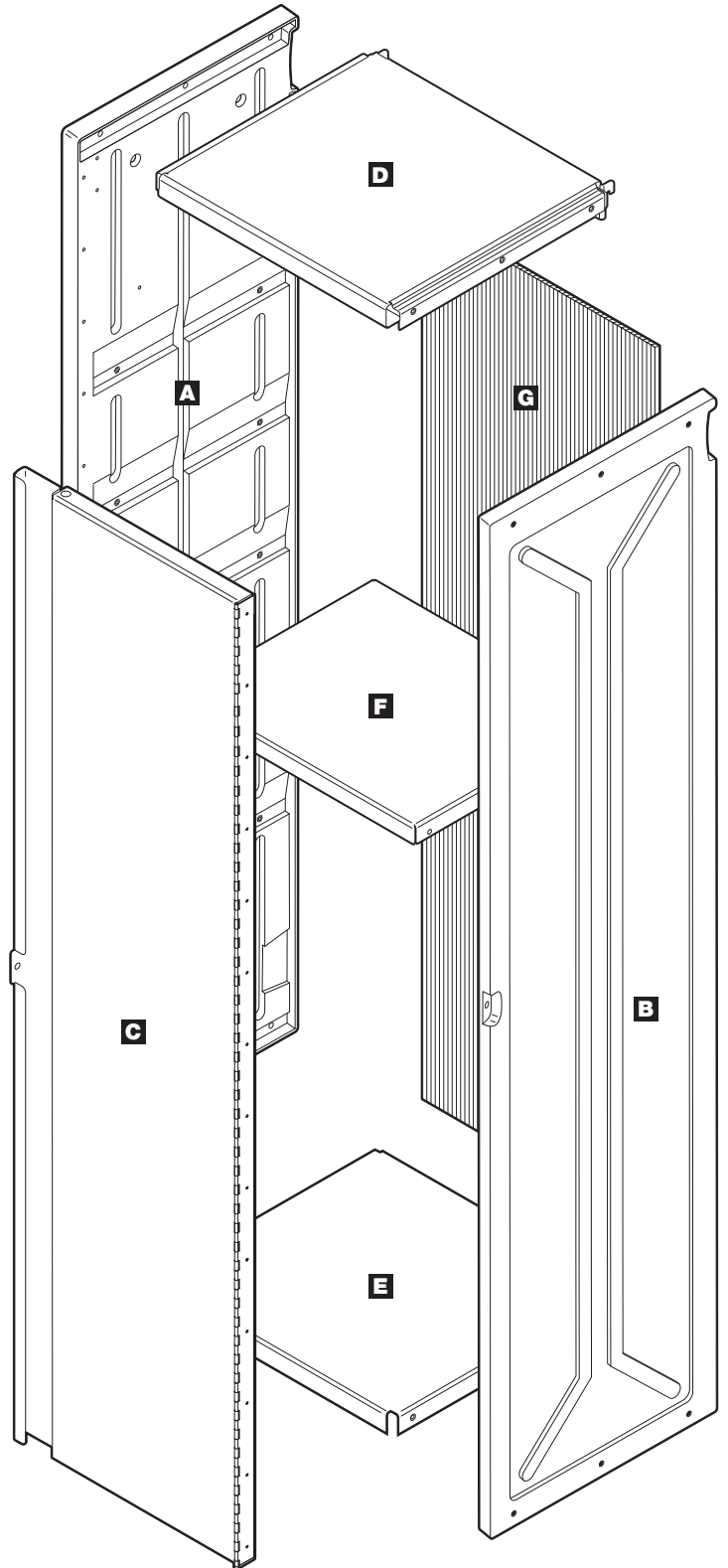

## STEP 1

### INSTALL DOOR PANEL TO SIDE PANEL

Choose door opening orientation: left-hand or right-hand. Hinge screw locations indicate front edge of side panels (A & B).

NOTE: Instructions indicate the door mounted to the left side panel (B).

HINT: Use the other side panel (A) to hold the door up to the level for ease of alignment.

Place door (C) into position, align TOP hinge hole with side panel (B) screw boss. You will need fourteen hinge screws (H) for assembly.

1. Install top screw (1).
2. Align bottom hole and install screw (2).
3. Install remaining screws in sequence (3-14).

CAUTION: Do not over-tighten screws.

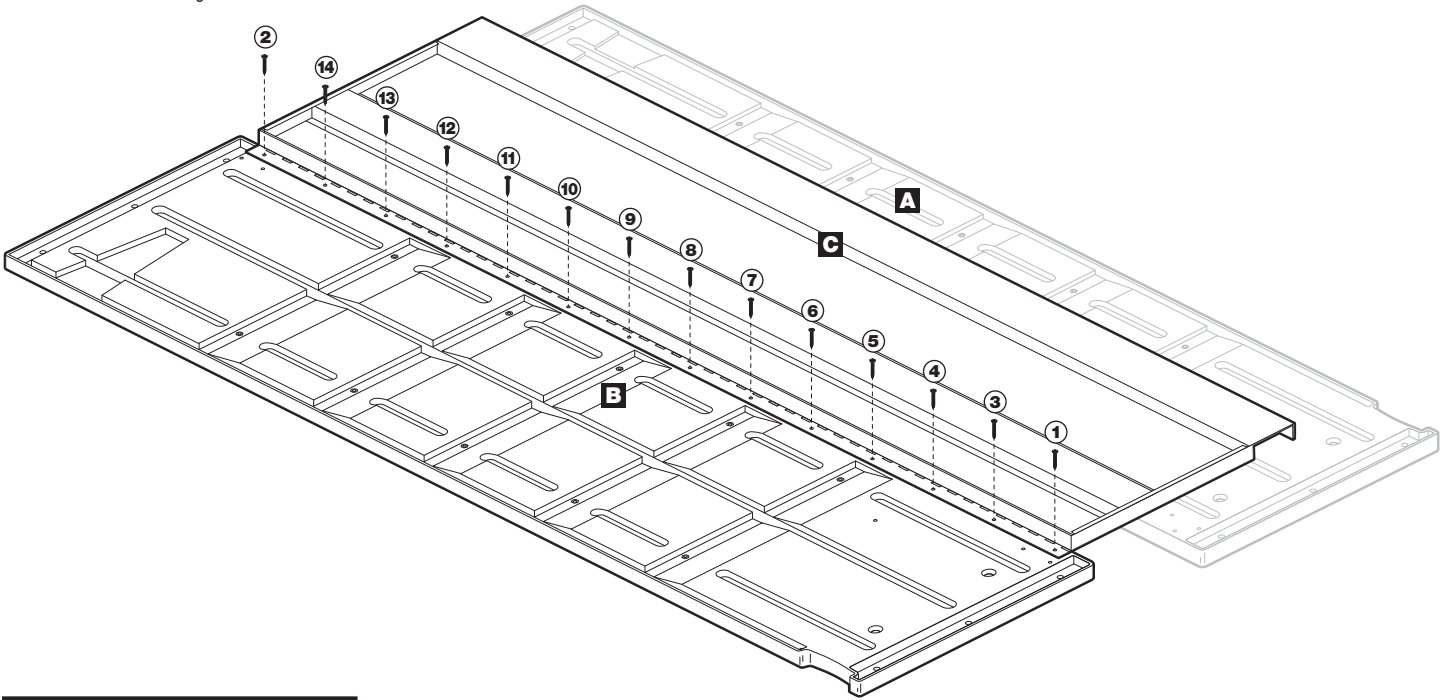

## STEP 2

### INSTALL DOOR MAGNETS TO SIDE PANEL

Choose remaining side panel (A or B). Position magnet (I) to align with mounting holes in side panel (A).

Install using two magnet screws (J).

NOTE: The magnet position may need adjustment after complete assembly to ensure proper door alignment.

Repeat for opposite end, ensuring a magnet is mounted at top and bottom of side panel.

CAUTION: Do not over-tighten screws.

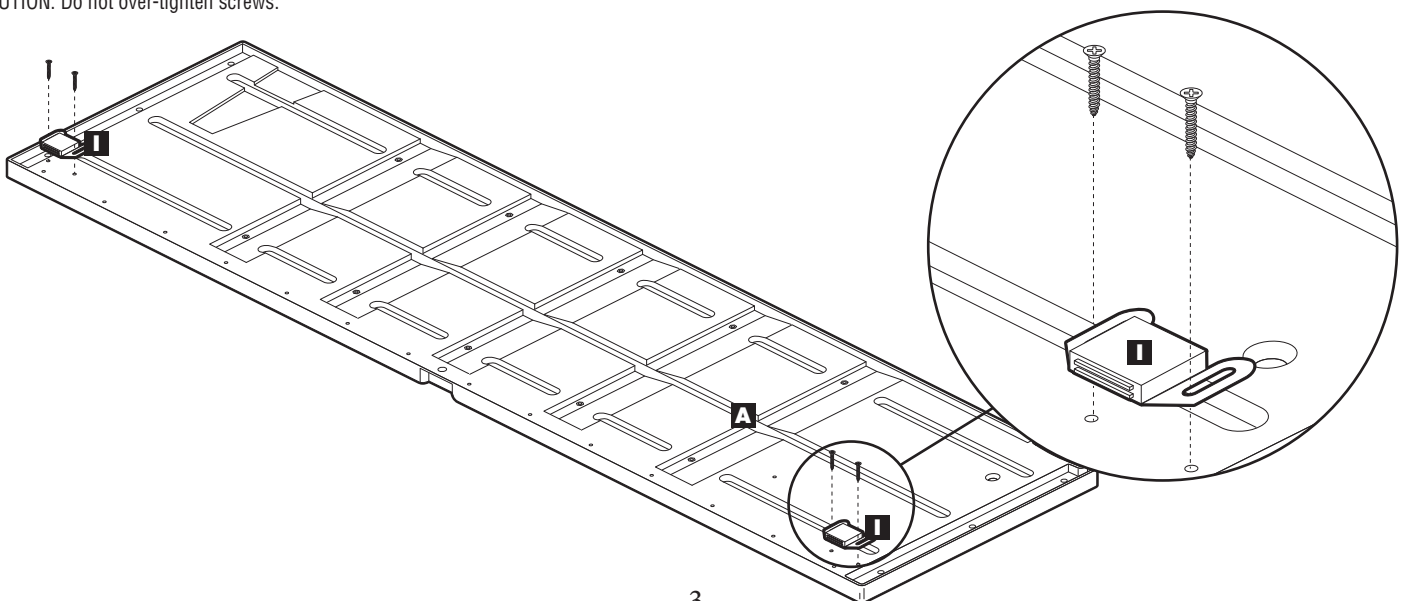

### STEP 3

#### INSTALL TOP PANEL TO SIDE PANEL

With door panel laying flat, move side panel (B) into a vertical position. Position top panel (D) into side panel groove and align.

Using three side panel screws (K) install in the order shown.

CAUTION: Do not over-tighten screws.

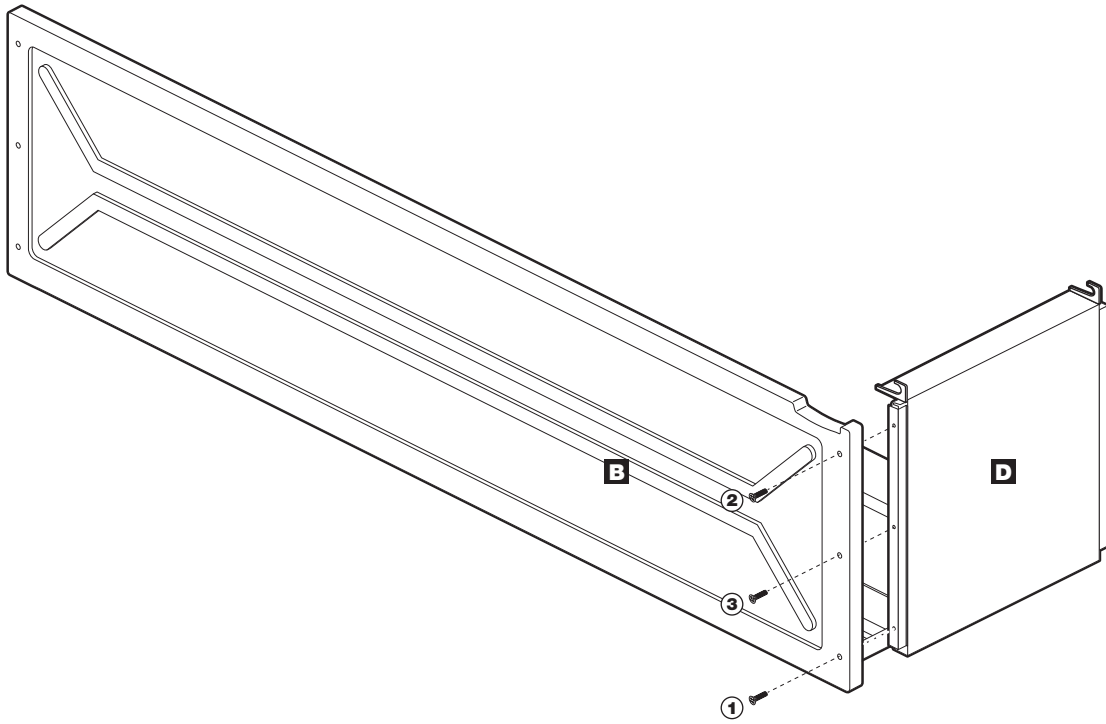

### STEP 4

#### INSTALL BOTTOM PANEL TO SIDE PANEL

Position bottom panel (E) into side panel groove and align.

Using three side panel screws (K) install in the order shown.

CAUTION: Do not over-tighten screws.

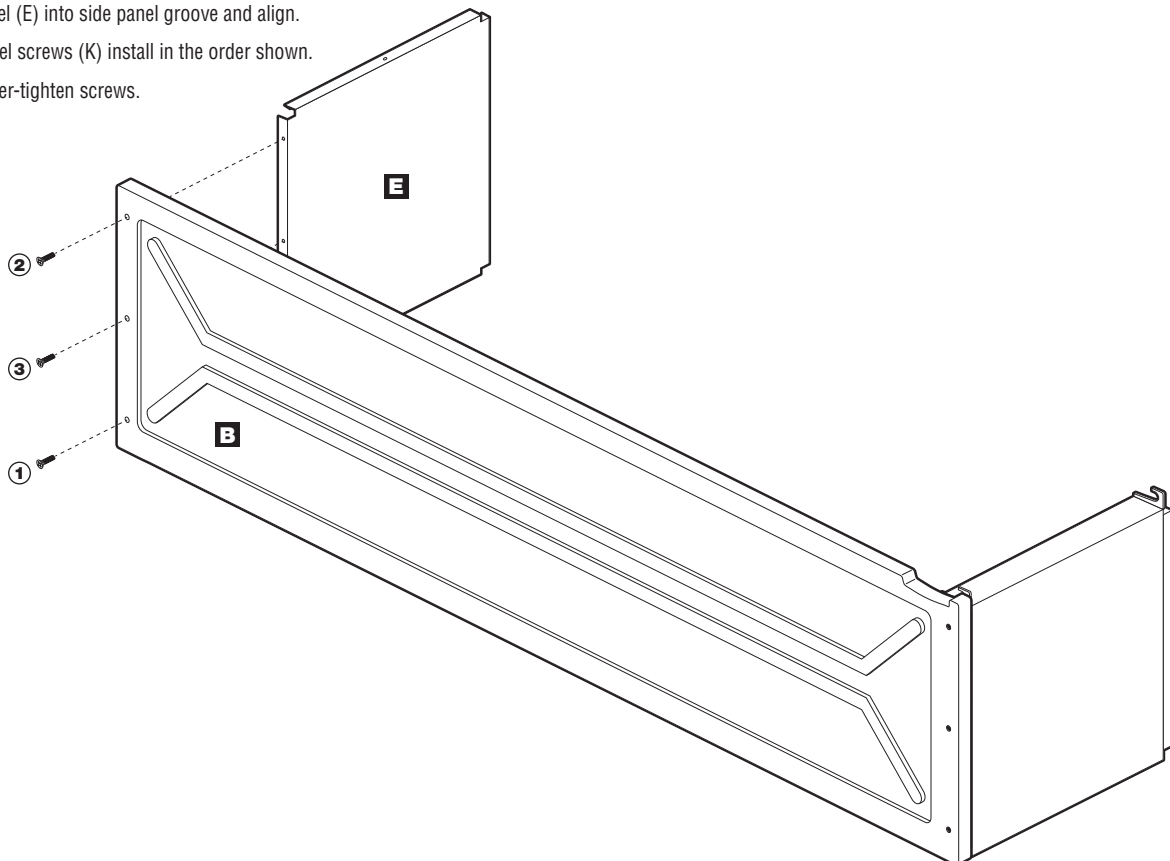

## STEP 5

### INSTALL REMAINING SIDE PANEL TO BOTTOM PANEL AND TOP PANEL

Position top panel (D) and bottom panel (E) into side panel (A) grooves and align.

Using six side panel screws (K) install in the order shown.

**CAUTION:**  
Do not over-tighten screws.

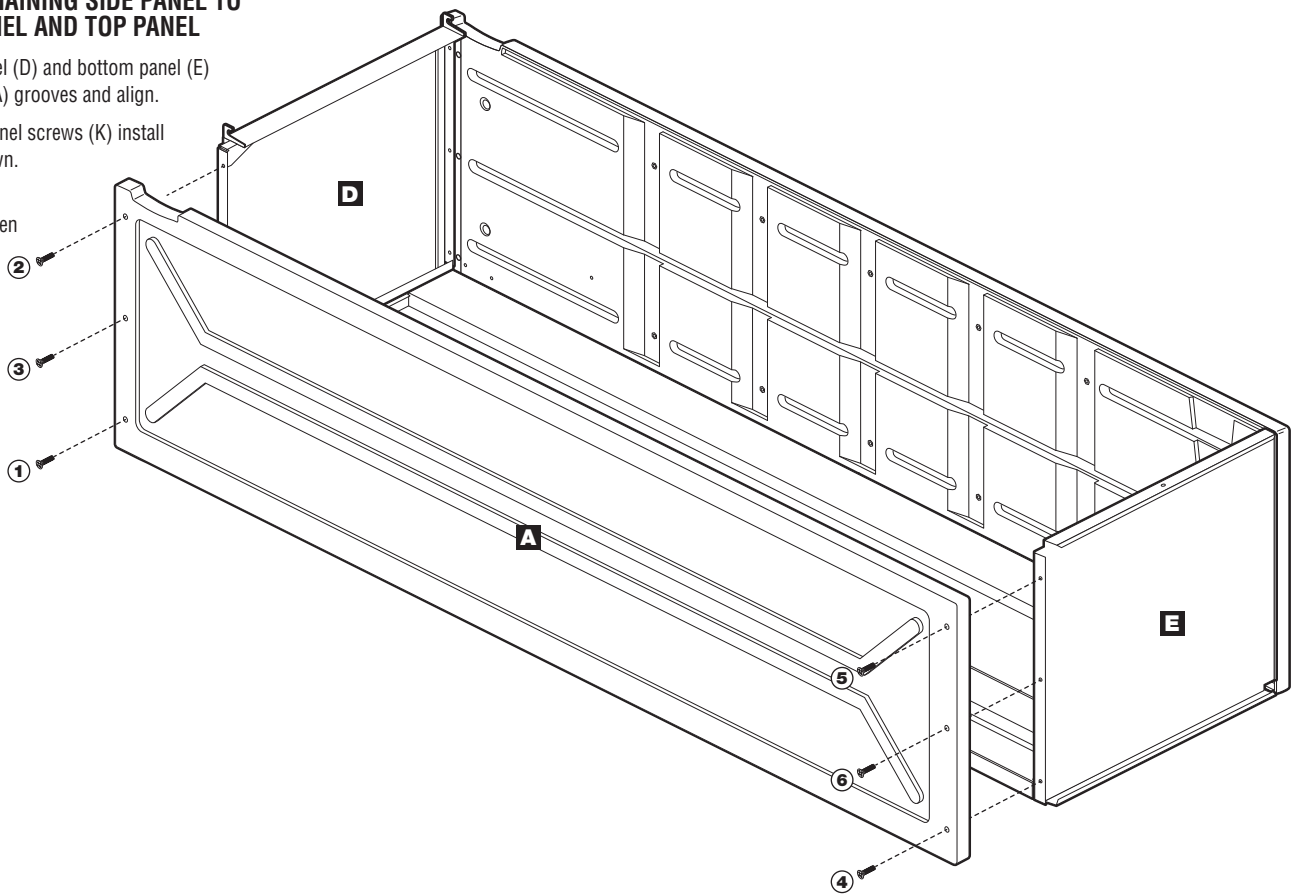

## STEP 6

### INSTALL BACK PANEL

Stand unit upright.

1. Position back panel (G) into rear groove of left side panel and hold into place.
2. Push right side of back panel into the rear groove of the right panel.

**NOTE:** Back panel will flex until it snaps into the rear groove.

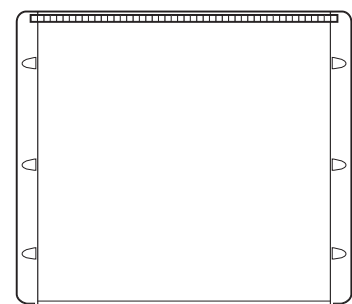
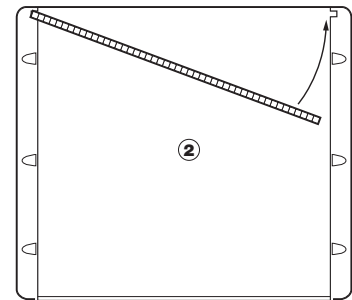
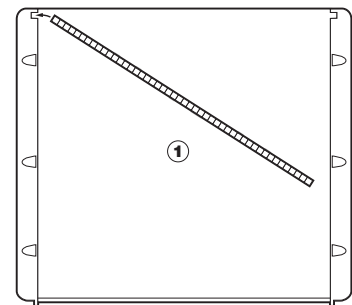
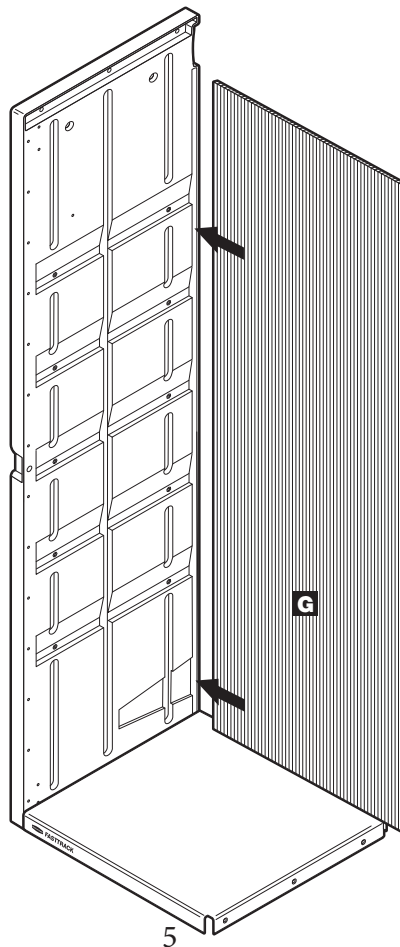

## STEP 7

### INSTALL SHELF

TIP: Use a magnetized tip screwdriver.

Lay the locker onto its side, hinge-side down, and open the door.

Position shelf (F) in any of the provided mounting positions.

NOTE: Slotted hole should be oriented towards the rear of the unit with the round hole oriented towards the front of the unit.

Attach shelf (F) by inserting four shelf screws (L) into the molded-in nut on the side panels.

1. Align and install front screws.
2. Align and install back screws.

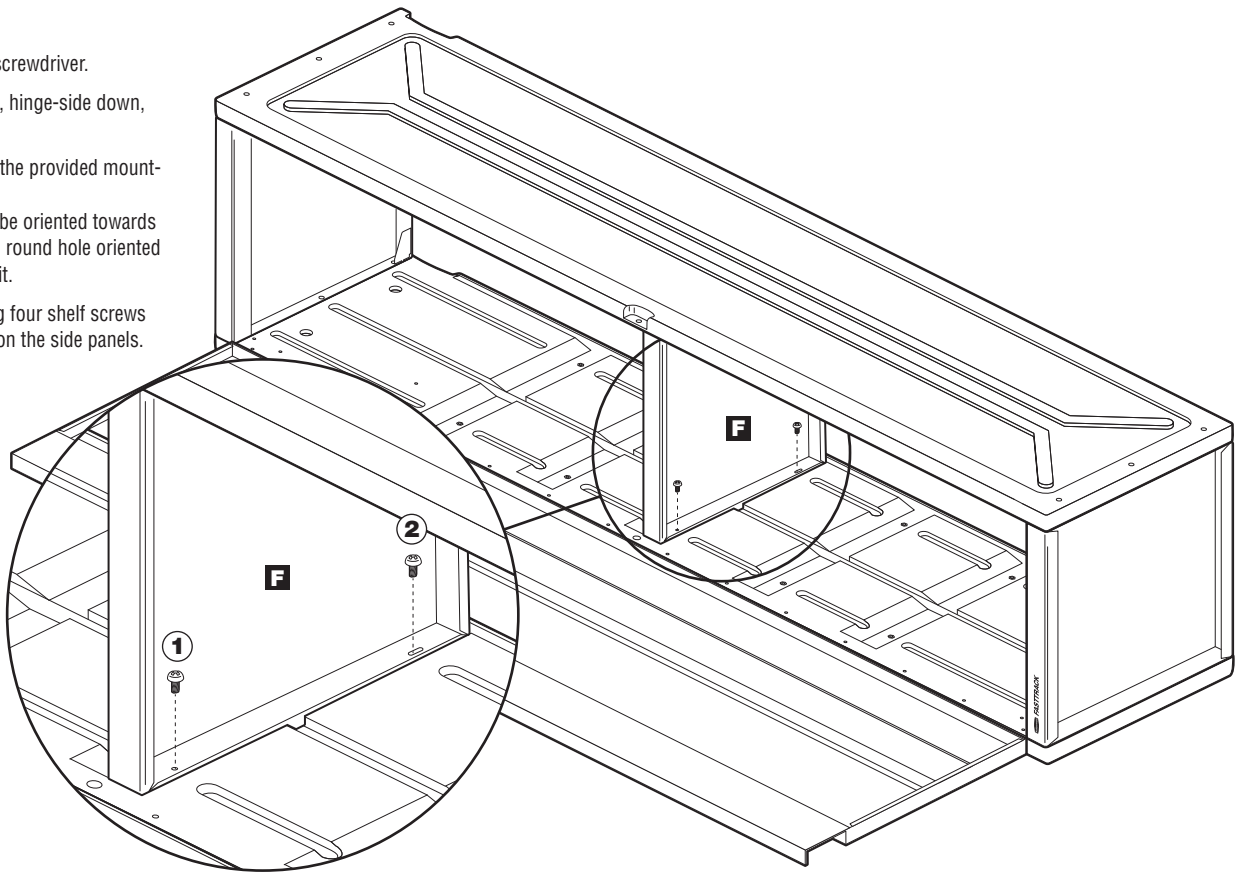

## STEP 8

### INSTALLING THE LOCKER TO THE RAIL

NOTE: FastTrack rail is sold separately.

Place unit onto the rail in the location desired.

Tabs on the back of the top panel "hook" onto the rail.

NOTE: Be sure the FastTrack rail is installed per its instructions, and level.

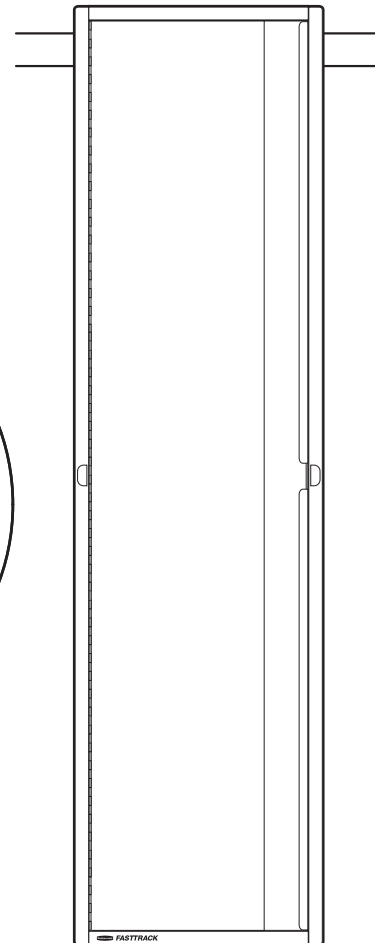
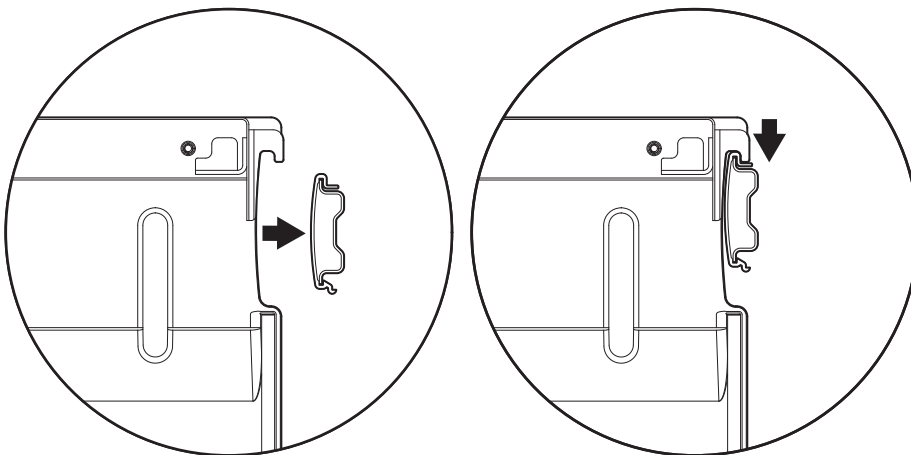

## STEP 9

### PREPARE FOR CABINET MOUNTING

Mark the hole location at the back of the bottom panel (Located underneath bottom panel).

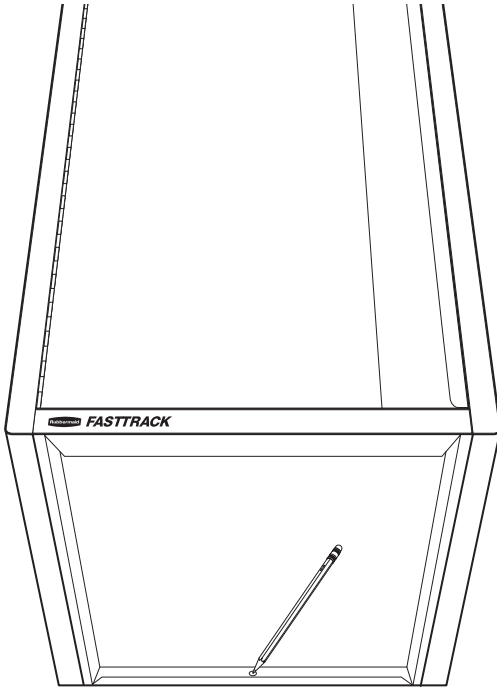

### ALTERNATE ANCHOR POINTS FOR LOWER LOCKER

If the bottom of the lower locker is close to the floor and prevents reasonable access to installing the wall anchor and screw below the bottom panel, two alternate locations are provided close to the lower end, inside each side panel.

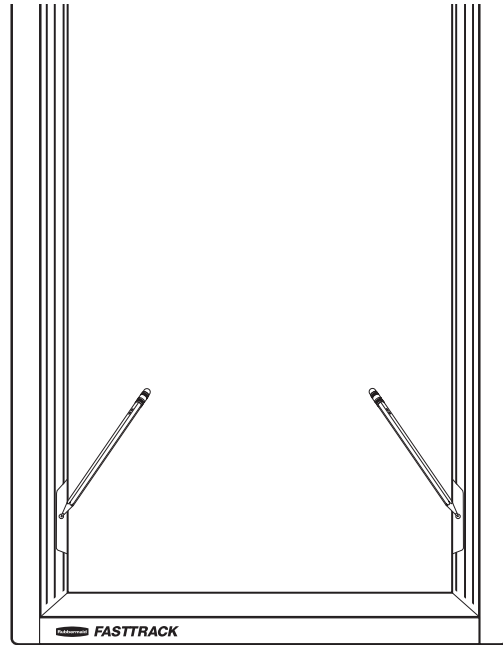

## STEP 10

### MOUNT CABINET TO WALL

Remove the unit from the rail and install the wall anchor (M) using a 5/16" drill bit, or drill an 1/8" pilot-hole if a stud aligns with the location.

Place the unit back onto the rail and align the hole with the wall anchor (M) or pilot hole.

Install the anchor screw (N) into the wall anchor or pilot hole.

CAUTION: Do not over-tighten screws.

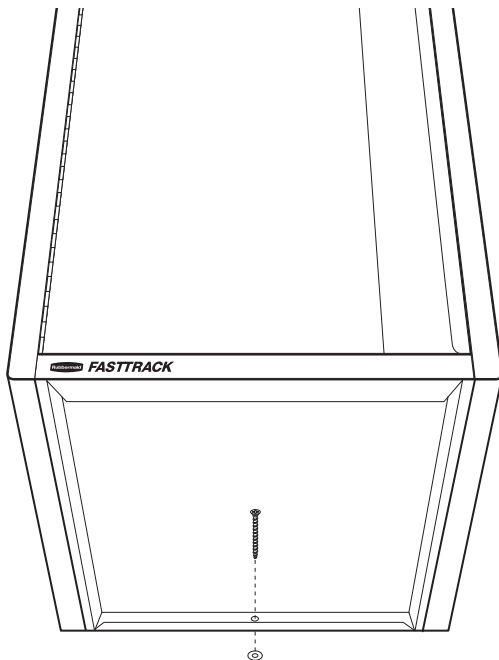

### ALTERNATE ANCHOR POINTS FOR LOWER LOCKER

Remove the unit from the rail and install the wall anchors (M) using a 5/16" drill bit, or drill an 1/8" pilot-hole if a stud aligns with the location.

Place the unit back onto the rail and align the hole with the wall anchor (M).

Install the anchor screw (N) into the wall anchor or pilot hole.

CAUTION: Do not over-tighten screws.

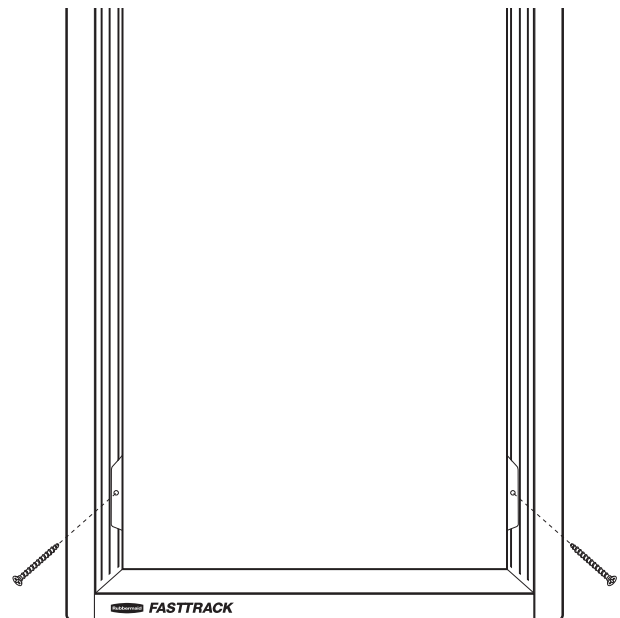

## STEP 11

### SQUARE UP CABINET

Adjust the top of the unit left or right as needed to square the door (bump either side next to the rail at top, back).

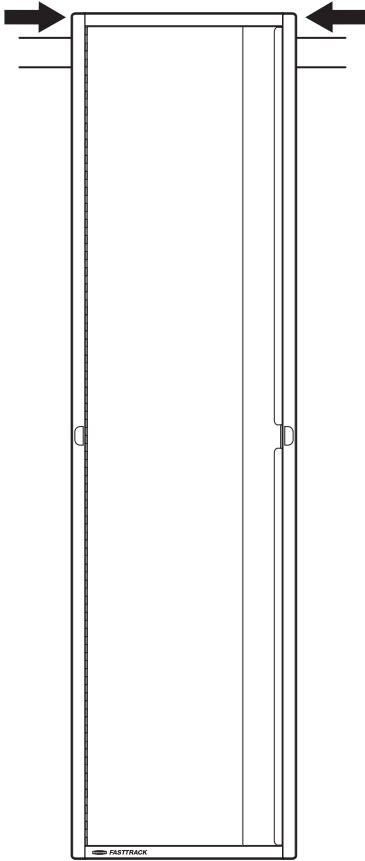

## STEP 12

### MOUNT CABINET TO WALL

Install the keeper-brackets (O) at the back of each side panel, right below the rail. Use one keeper bracket screw (H) per side.

CAUTION: Do not over-tighten screws.

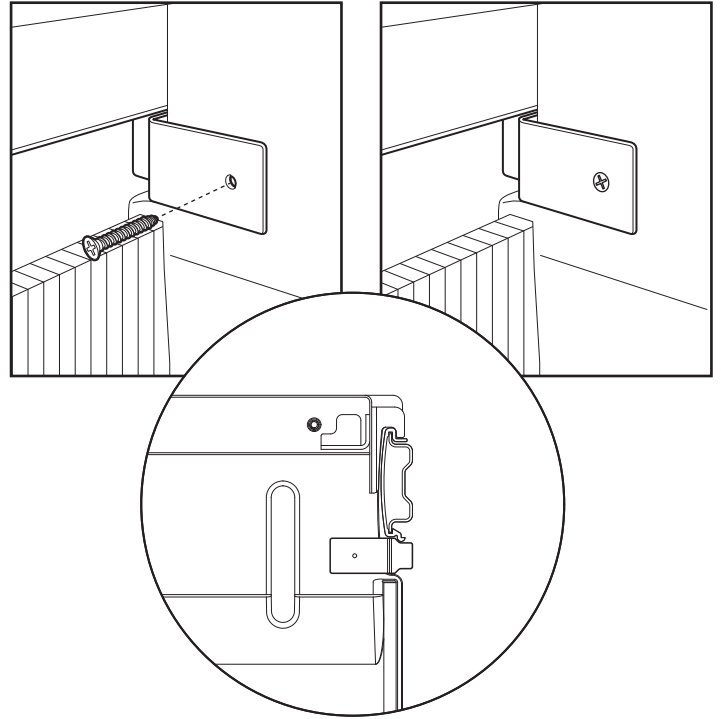



**Rubbermaid**®

# FASTTRACK®

## Casier inférieur - 7W96 Étapes d'assemblage



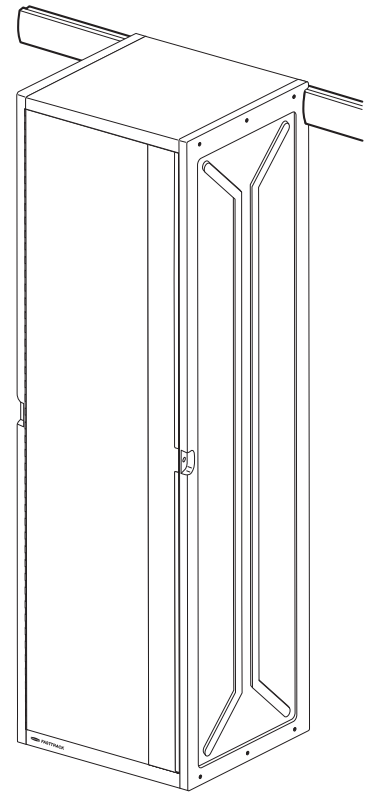
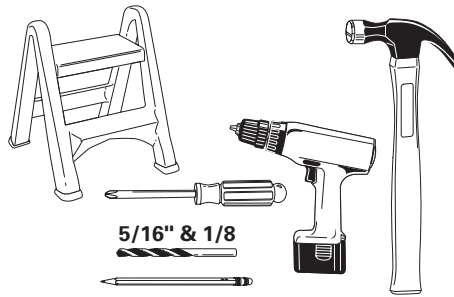

2001932

Rubbermaid Incorporated,  
Huntersville, NC, États-Unis 28078 - 1801  
U.S.A. 1-888-895-2110  
Canada 1-866-595-0525  
[www.rubbermaid.com](http://www.rubbermaid.com)

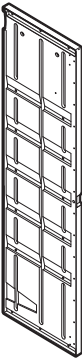
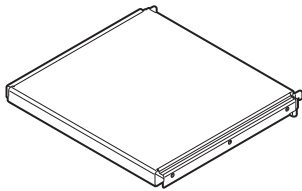
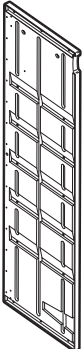
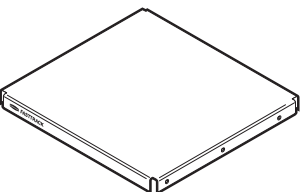
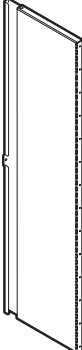
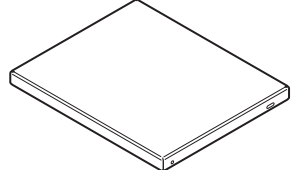
**newell**  
BRANDS

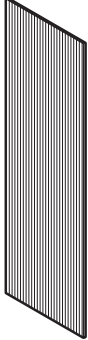

Pièces	Qté.	Pièces	Qté.
<b>A</b> Panneau latéral droit 	1	<b>D</b> Haut 	1
<b>B</b> Panneau latéral gauche 	1	<b>E</b> Bas 	1
<b>C</b> Porte 	1	<b>F</b> Étagère 	1

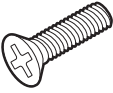
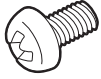
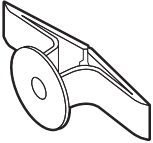
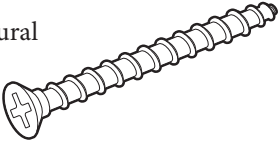
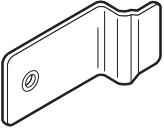
Pièces	Qté.
<b>G</b> Panneau arrière 	1
<b>H</b> Vis pour charnière et support de retenue M2.9 x 19mm 	16
<b>I</b> Aimant 	2
<b>J</b> Vis pour l'aimant n° 6 - 32 x 2 cm (¾ po) 	4
<b>K</b> Vis du panneau latéral n° 10 - 32 x 2 cm (¾ po) 	12
<b>L</b> Vis pour étagère M5 x 8 mm 	4
<b>M</b> Ancrage mural 	2
<b>N</b> Vis pour l'ancrage mural n° 10 x 5 cm (2 po) 	2
<b>O</b> Supports de retenue 	2

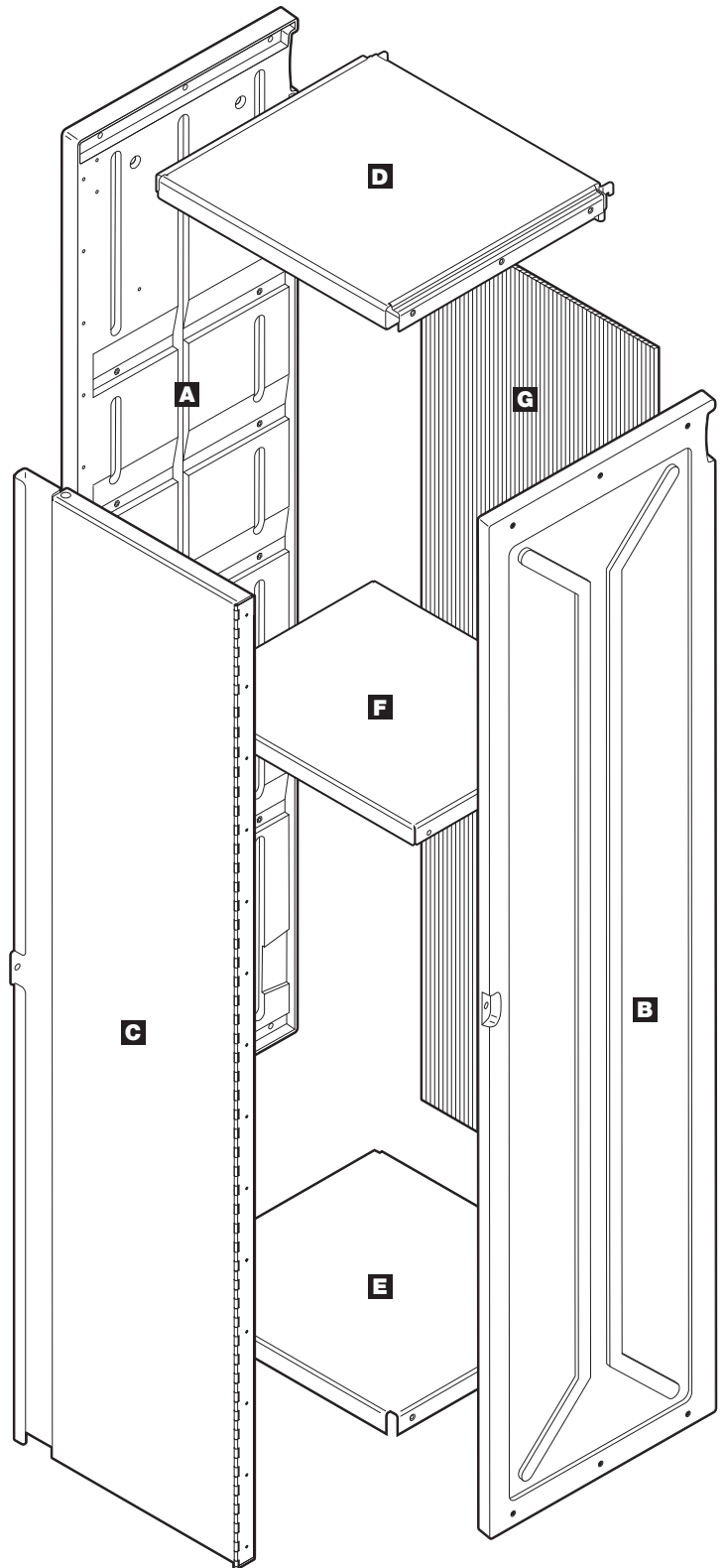

## ÉTAPE 1

### FIXER LE PANNEAU DE PORTE AU PANNEAU LATÉRAL

Choisissez l'orientation d'ouverture de la porte : à gauche ou à droite. Les emplacements des vis de charnière indiquent le bord avant des panneaux latéraux (A et B).

REMARQUE : Les instructions indiquent la porte montée sur le panneau latéral gauche (B).

INDICE: Utilisez l'autre panneau latéral (A) pour maintenir la porte au niveau pour faciliter l'alignement.

Placez la porte (C) en position, alignez le trou SUPÉRIEUR de la charnière comprenant le bossage pour vis du panneau latéral (B). Vous aurez besoin de quatorze vis à charnière (H) pour l'assemblage.

1. Installez la vis supérieure (1).
2. Alignez le trou inférieur et fixez la vis (2).
3. Installez les vis restantes en séquence (de 3 à 14).

ATTENTION : Ne pas trop serrer les vis.

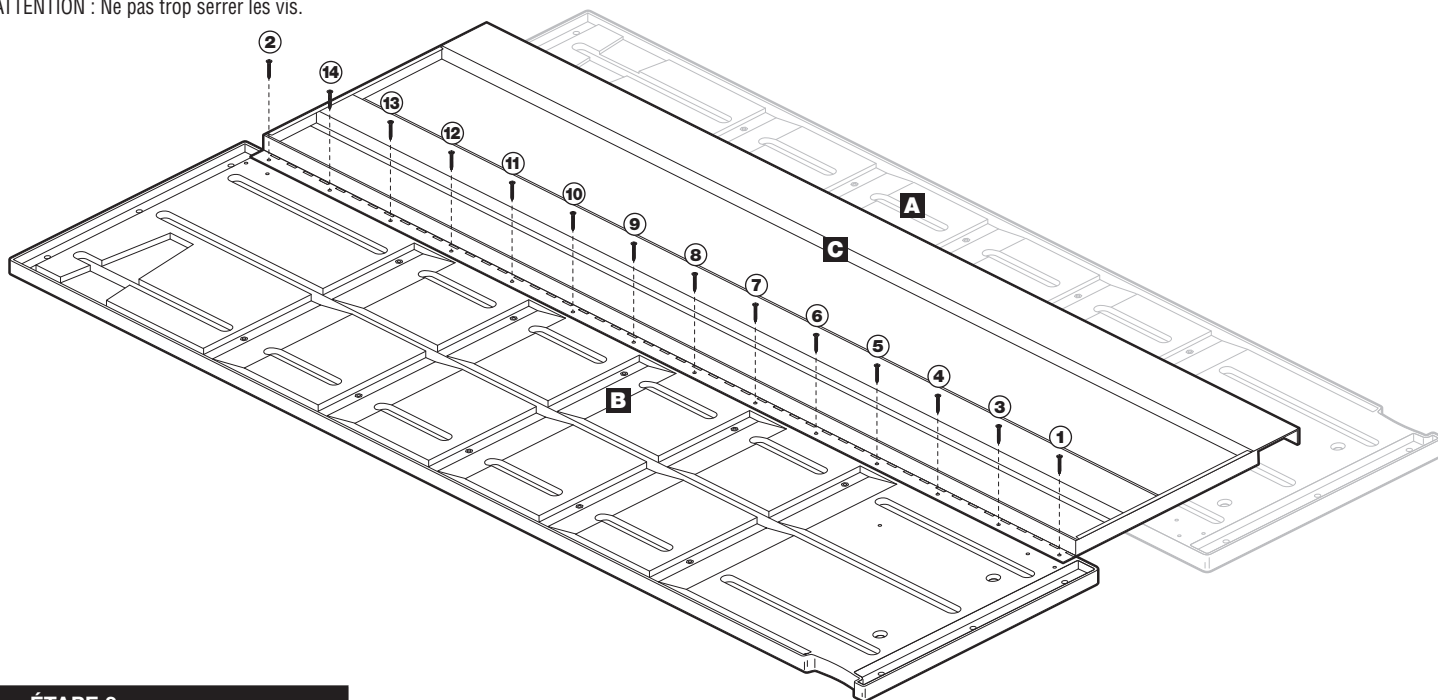

## ÉTAPE 2

### FIXER LES AIMANTS DE PORTE AU PANNEAU LATÉRAL

Choisissez le panneau latéral restant (A ou B). Positionnez l'aimant (I) pour aligner avec les trous de montage dans le panneau latéral (A).

Fixez à l'aide des deux vis pour aimant (J).

REMARQUE : La position de l'aimant peut nécessiter un réglage après l'assemblage complet pour assurer un alignement correct de la porte.

Répétez de l'autre côté, veillant à ce qu'un aimant soit fixé aux parties supérieure et inférieure du panneau latéral.

ATTENTION : Ne pas trop serrer les vis.

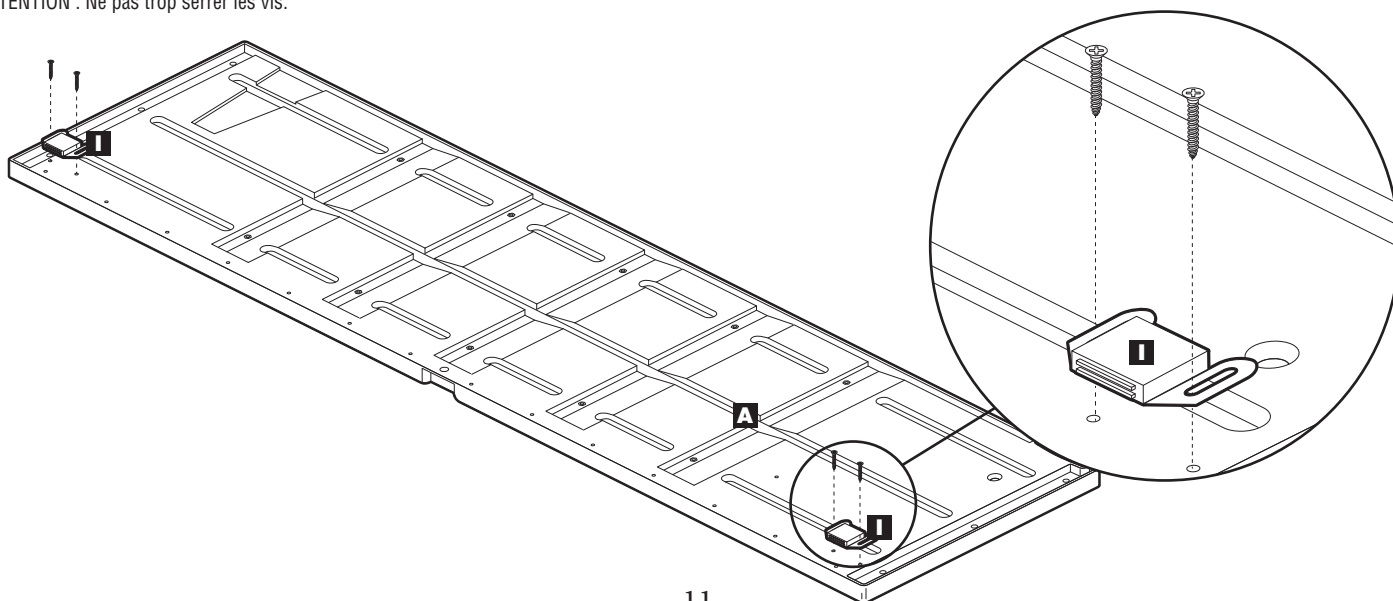

### ÉTAPE 3

#### FIXER LE PANNEAU SUPÉRIEUR AU PANNEAU LATÉRAL

Posez le panneau de la porte à plat et déplacez le panneau latéral (B) en position verticale.  
Positionnez le panneau supérieur (D) dans la rainure du panneau latéral et alignez-le.

À l'aide des trois vis de panneau latéral (K), montez-les dans l'ordre indiqué.

ATTENTION : Ne pas trop serrer les vis.

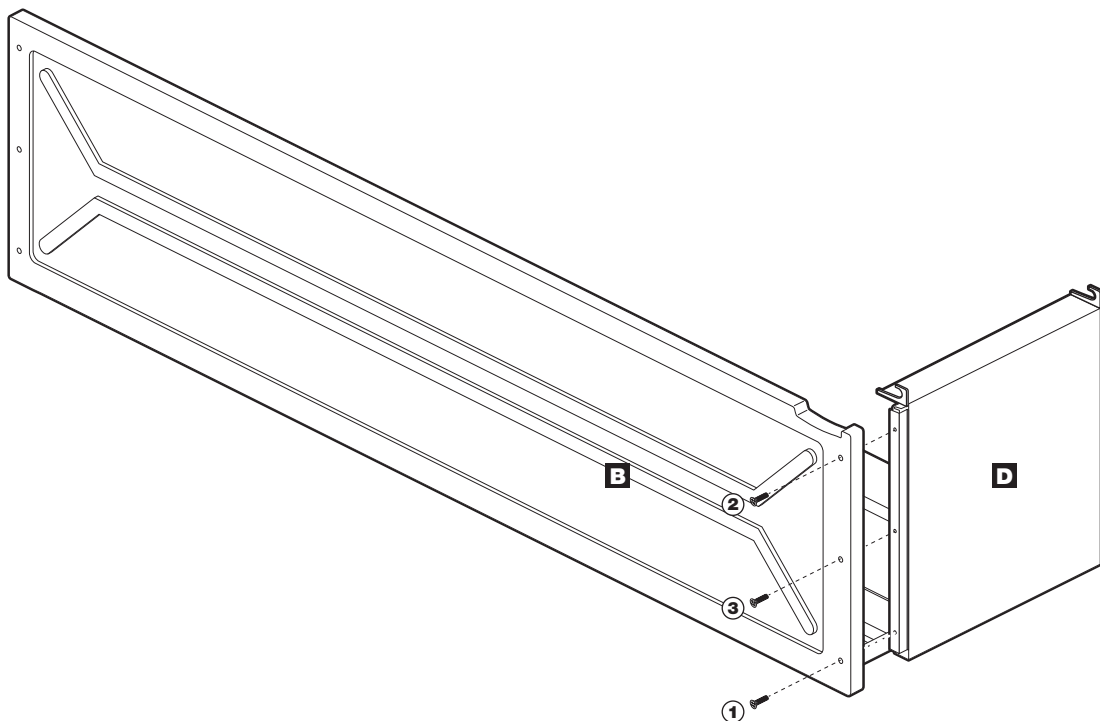

### ÉTAPE 4

#### FIXER LE PANNEAU INFÉRIEUR AU PANNEAU LATÉRAL

Positionnez le panneau inférieur (E) dans la rainure du panneau latéral et alignez-le.

À l'aide des trois vis de panneau latéral (K), montez-les dans l'ordre indiqué.

ATTENTION : Ne pas trop serrer les vis.

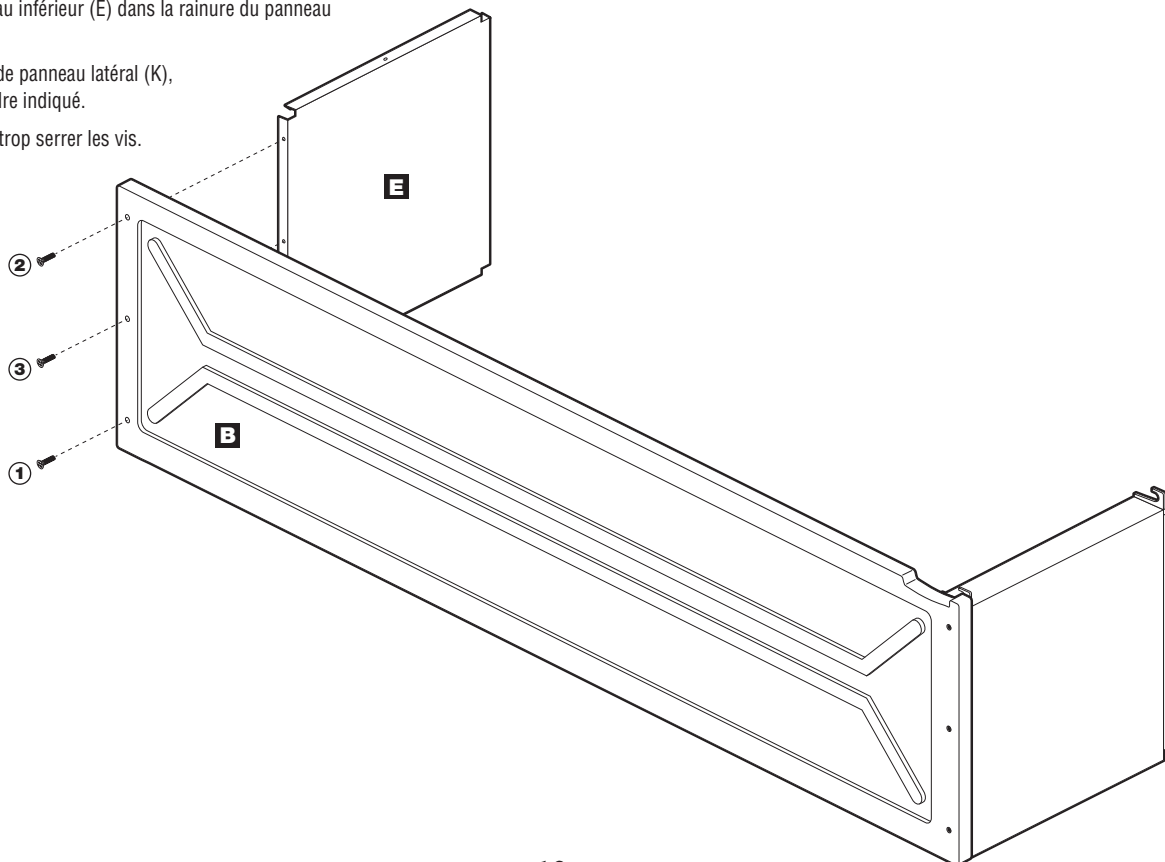

## ÉTAPE 5

### FIXER LE PANNEAU LATÉRAL RESTANT AUX PANNEAUX INFÉRIEUR ET SUPÉRIEUR

Positionnez le panneau supérieur (D) et le panneau inférieur (E) dans les rainures du panneau latéral (A) et alignez-les.

À l'aide des six vis de panneau latéral (K), montez-les dans l'ordre indiqué.

ATTENTION :

Ne pas trop serrer les vis.

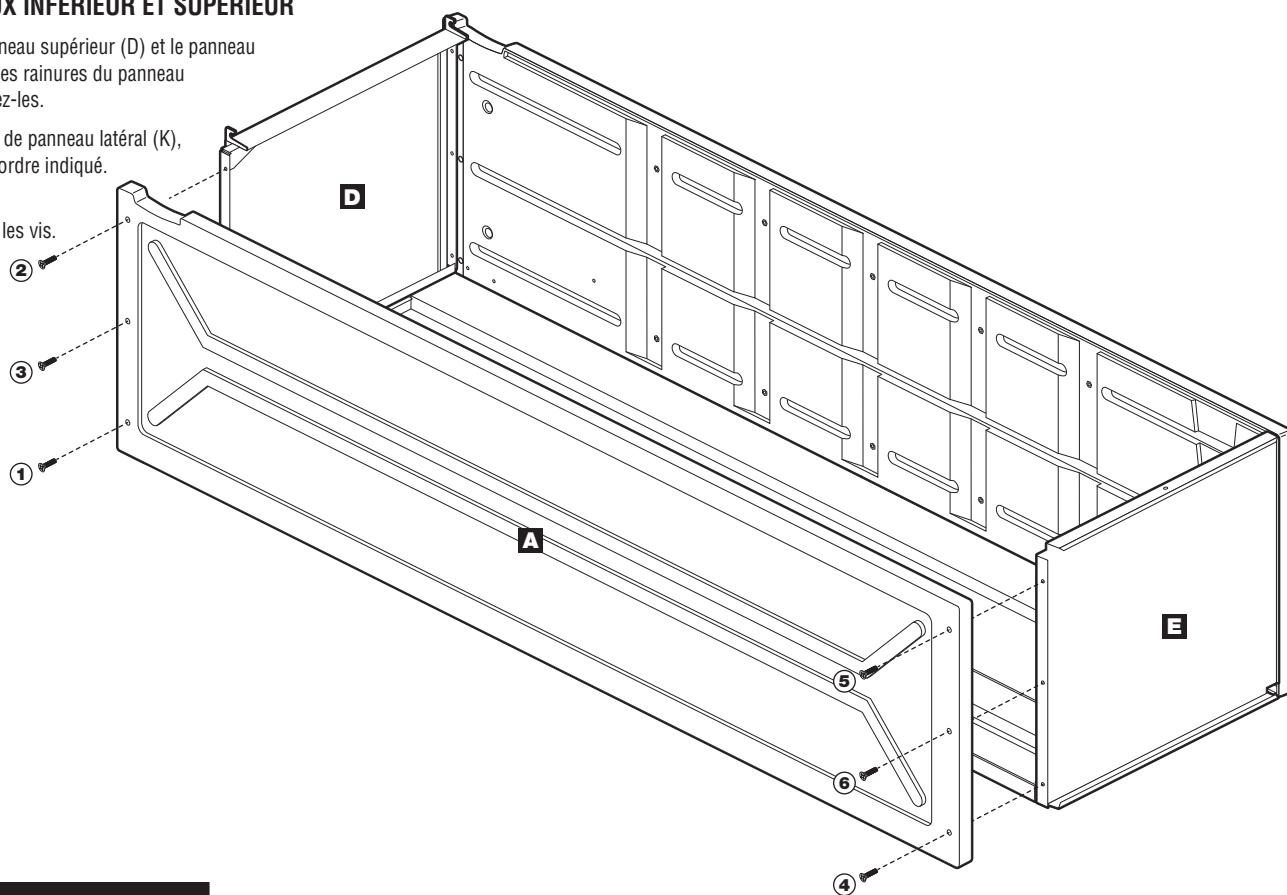

## ÉTAPE 6

### FIXER LE PANNEAU ARRIÈRE

Mettre l'unité en position verticale.

1. Positionnez le panneau arrière (G) dans la rainure arrière du panneau latéral gauche et maintenez-le en place.
2. Poussez le côté droit du panneau arrière dans la rainure arrière du panneau droit.

REMARQUE : Le panneau arrière fléchira jusqu'à ce qu'il s'enclenche dans la rainure arrière.

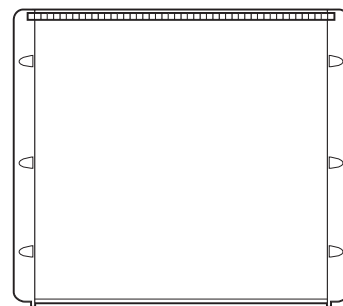
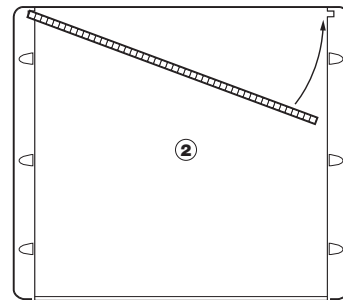
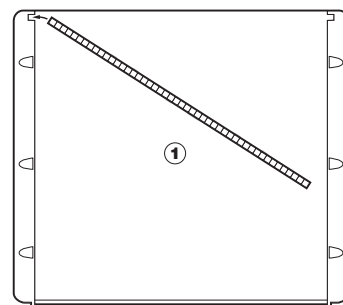
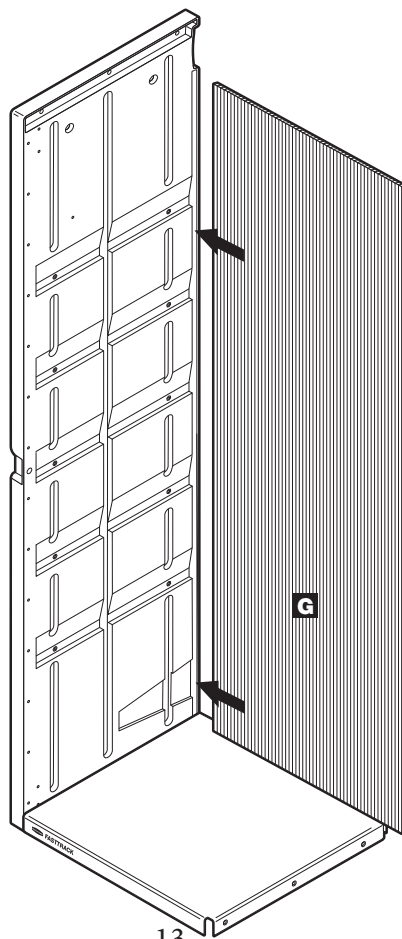

## ÉTAPE 7

### INSTALLER L'ÉTAGÈRE

ASTUCE : Utilisez un tournevis à pointe magnétique.

Placez le casier sur son côté, avec le côté avec charnière vers le bas, et ouvrez la porte.

Placez l'étagère (F) dans l'une des positions de montage fournies.

REMARQUE : Le trou oblong doit être orienté vers l'arrière de l'unité avec le trou rond orienté vers l'avant de l'unité.

Fixez l'étagère (F) en insérant quatre vis à étagère (L) dans l'écrou moulé sur les panneaux latéraux.

1. Alignez et installez les vis avant.
2. Alignez et installez les vis arrière.

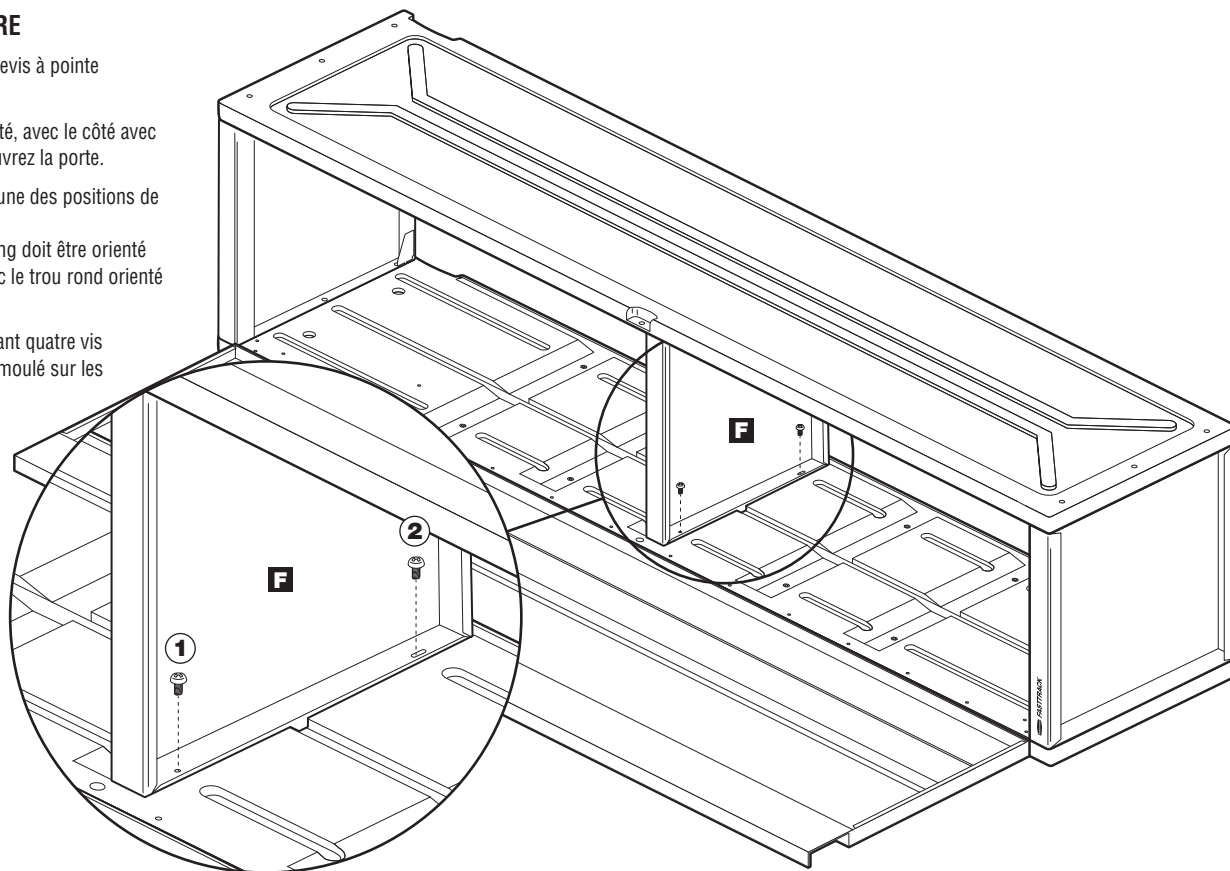

## ÉTAPE 8

### FIXER LE CASIER AU RAIL

REMARQUE : Le rail FastTrack est vendu séparément.

Placez l'unité sur le rail à l'emplacement désiré.

Les languettes situées à l'arrière du panneau supérieur « s'accrochent » au rail.

REMARQUE : Assurez-vous que le rail FastTrack est installé selon ses instructions et qu'il est de niveau.

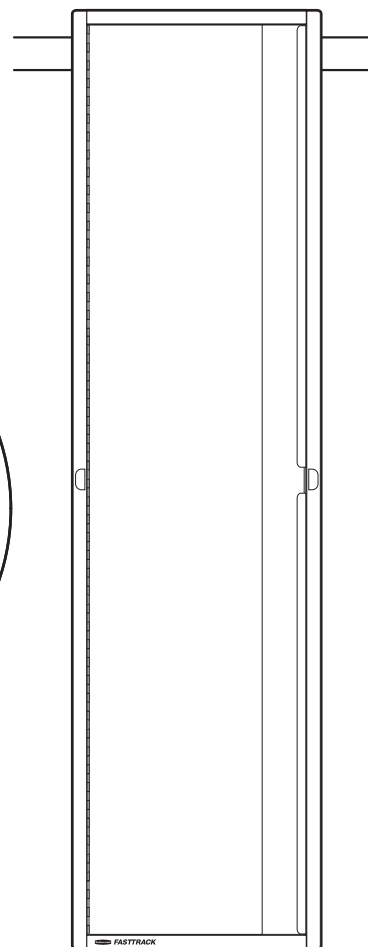
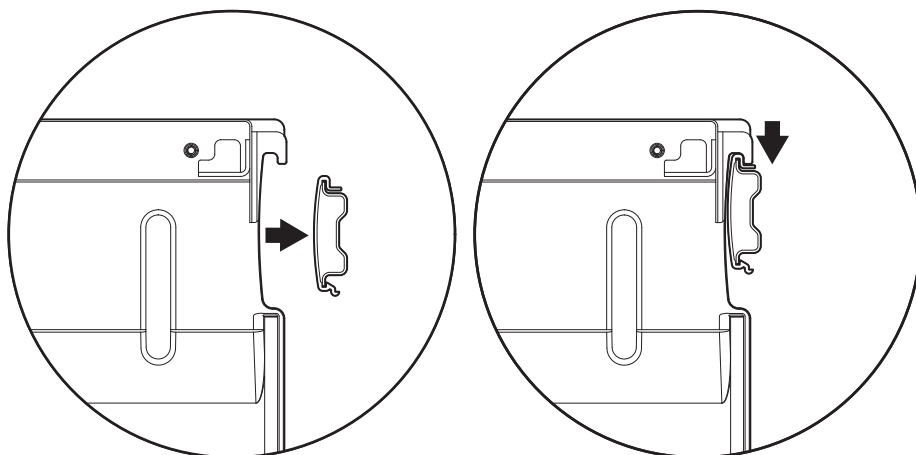

## ÉTAPE 9

### PRÉPARATION POUR L'ASSEMBLAGE DE L'ARMOIRE

Marquez l'emplacement du trou à l'arrière du panneau inférieur (situé sous le panneau inférieur).

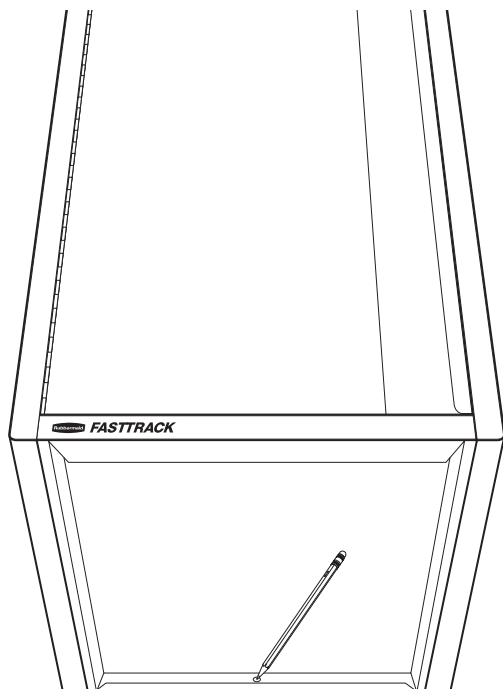

### POINTS D'ANCRAGE ALTERNATIFS POUR LE CASIER INFÉRIEUR

Si le bas du casier inférieur est près du sol et empêche un accès raisonnable à l'installation de l'ancrage murale et de la vis sous le panneau inférieur, deux emplacements alternatifs sont prévus près de l'extrémité inférieure, à l'intérieur de chaque panneau latéral.

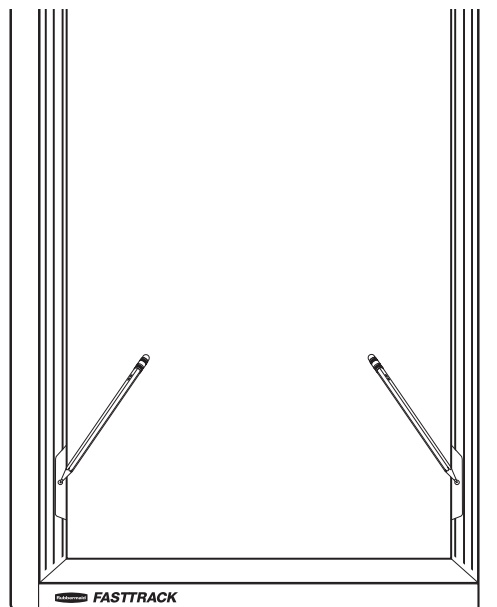

## ÉTAPE 10

### FIXER L'ARMOIRE AU MUR

Retirez l'unité du rail et installez l'ancrage murale (M) à l'aide d'un foret de 9,5 mm (5/16 po), ou percez un trou pilote de 3 mm (1/8 po) si un montant s'aligne avec l'emplacement.

Placez l'unité sur le rail et alignez le trou avec l'ancrage murale (M) ou le trou pilote.

Installez la vis d'ancrage (N) dans l'ancrage murale ou le trou pilote.

ATTENTION : Ne pas trop serrer les vis.

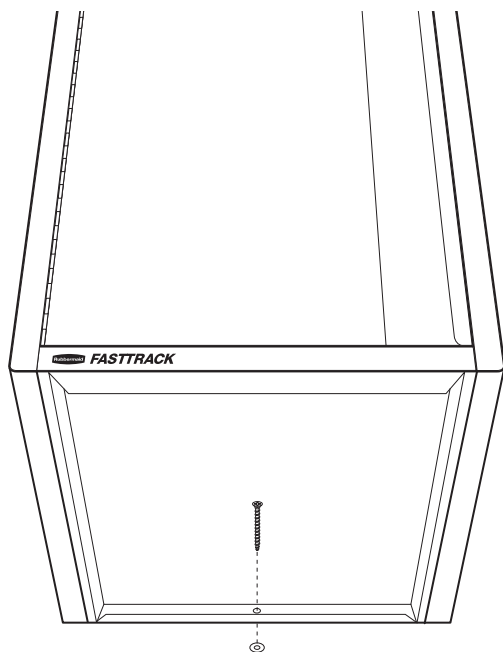

### POINTS D'ANCRAGE ALTERNATIFS POUR LE CASIER INFÉRIEUR

Retirez l'unité du rail et installez l'ancrage murale (M) à l'aide d'un foret de 9,5 mm (5/16 po), ou percez un trou pilote de 3 mm (1/8 po) si un montant s'aligne avec l'emplacement.

Placez l'unité sur le rail et alignez le trou avec l'ancrage murale (M).

Installez la vis d'ancrage (N) dans l'ancrage murale ou le trou pilote.

ATTENTION : Ne pas trop serrer les vis.

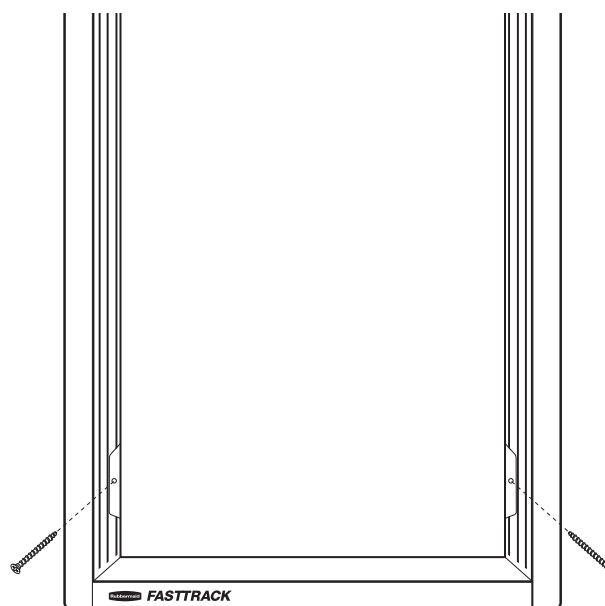

**ALIGNER L'ARMOIRE**

Réglez le haut de l'unité à gauche ou à droite au besoin pour aligner la porte (cognez les deux côtés à côté du rail en haut et en arrière).

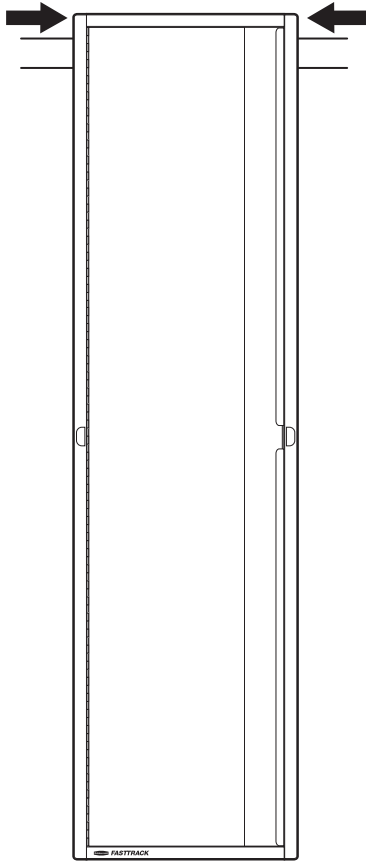
**FIXER L'ARMOIRE AU MUR**

Installez les supports de retenue (O) à l'arrière de chaque panneau latéral, juste en dessous du rail. Utilisez une vis de support de retenue (H) par côté.

ATTENTION : Ne pas trop serrer les vis.

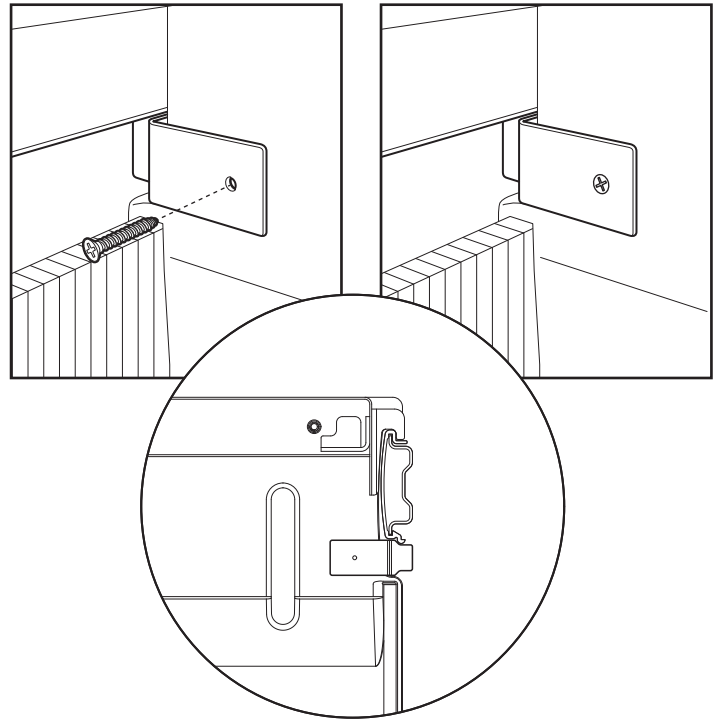



**Rubbermaid**®

# FASTTRACK®

## 7W96 – Armario inferior Pasos para el armado



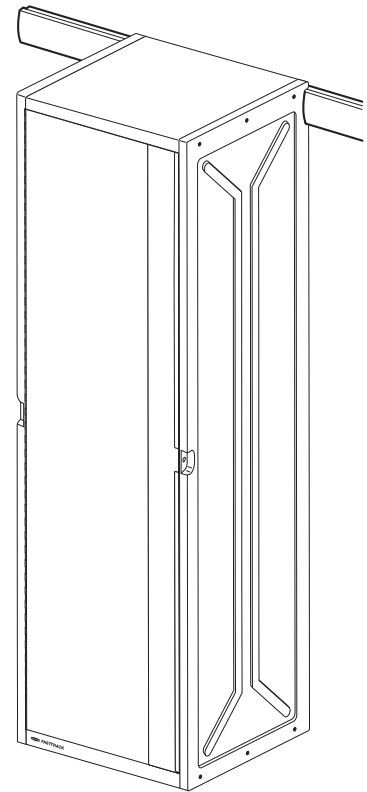
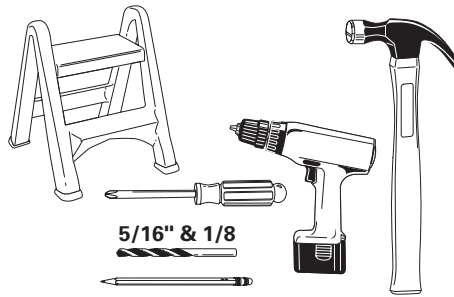

2001932

Rubbermaid Incorporated,  
Huntersville, NC U.S.A. 28078-1801  
Estados Unidos 1-888-895-2110  
Canadá 1-866-595-0525  
[www.rubbermaid.com](http://www.rubbermaid.com)

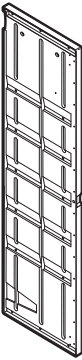
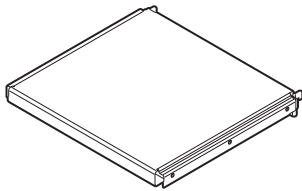
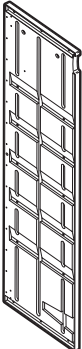
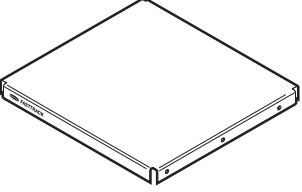
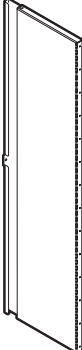
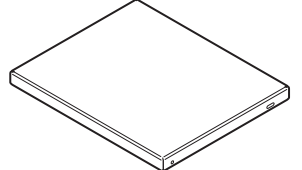
**newell**  
BRANDS

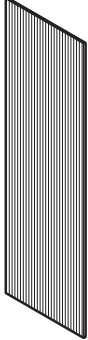

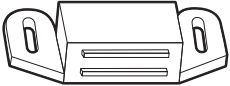
Piezas		Cantidad	Piezas		Cantidad
<b>A</b> Panel lateral derecho		1	<b>D</b> Parte superior		1
<b>B</b> Panel lateral izquierdo		1	<b>E</b> Parte inferior		1
<b>C</b> Puerta		1	<b>F</b> Estante		1

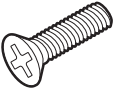
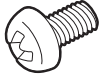
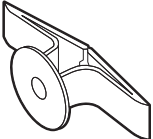
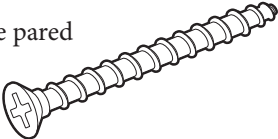
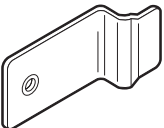
Piezas	Cantidad
<b>G</b> Panel posterior 	1
<b>H</b> Bisagra y tornillos para sujeción de soportes M2.9 x 19 mm 	16
<b>I</b> Imán 	2
<b>J</b> Tornillos magnéticos #6 x 3/4" 	4
<b>K</b> Tornillos de panel lateral #10-32 x 3/4" 	12
<b>L</b> Tornillos para estantes M5 x 8 mm 	4
<b>M</b> Anclaje de pared 	2
<b>N</b> Tornillo de anclaje de pared #10 x 2" 	2
<b>O</b> Sujeciones de soportes 	2

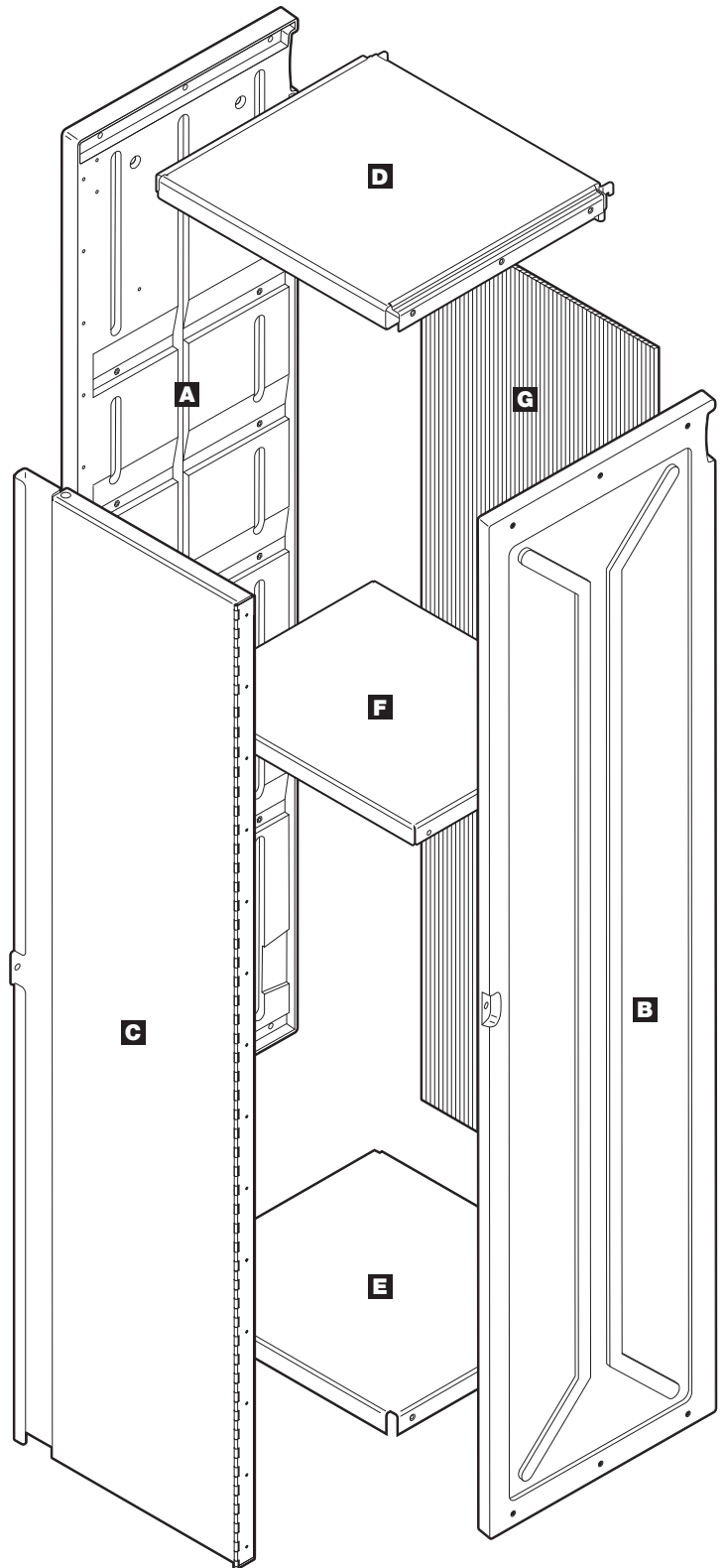

## PASO 1

### INSTALAR EL PANEL DE PUERTA PARA PANEL LATERAL

Elegir la orientación de apertura de la puerta: izquierda o derecha. La ubicación de los tornillos en la bisagra indica el borde frontal de los paneles laterales (A y B).

NOTA: Las instrucciones indican el montaje de la puerta en el panel lateral izquierdo (B).

INDICACIÓN: Utilizar el otro panel lateral (A) para mantener la puerta por encima del nivel y facilitar la alineación.

Colocar la puerta (C) en su posición, alinear el orificio de la bisagra SUPERIOR con el tornillo de refuerzo del panel lateral (B). Necesitará catorce tornillos de bisagra (H) para el armado.

1. Colocar el tornillo superior (1).
2. Alinear el orificio inferior y colocar el tornillo (2).
3. Colocar los tornillos restantes en secuencia (3-14).

PRECAUCIÓN: No ajustar demasiado los tornillos.

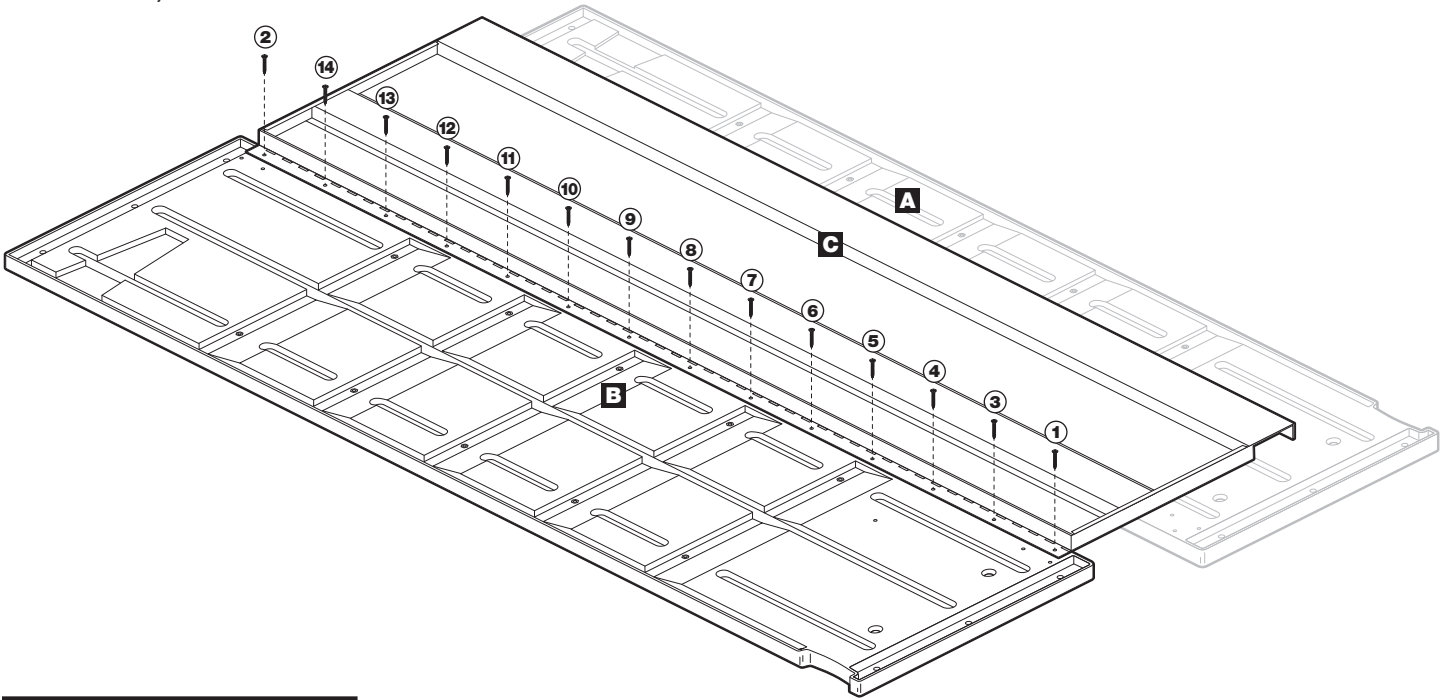

## PASO 2

### INSTALAR LOS IMANES DE LA PUERTA EN EL PANEL LATERAL

Seleccionar el panel lateral restante (A o B). Colocar el imán (I) de modo que quede alineado con los orificios de montaje en el panel lateral (A).

Colocar con dos tornillos magnéticos (J).

NOTA: Es posible que la ubicación del imán necesite un ajuste luego de completar el armado para asegurar una adecuada alineación de la puerta.

Repetir para el extremo opuesto y verificar que haya imanes colocados en la parte superior e inferior del panel lateral.

PRECAUCIÓN: No ajustar demasiado los tornillos.

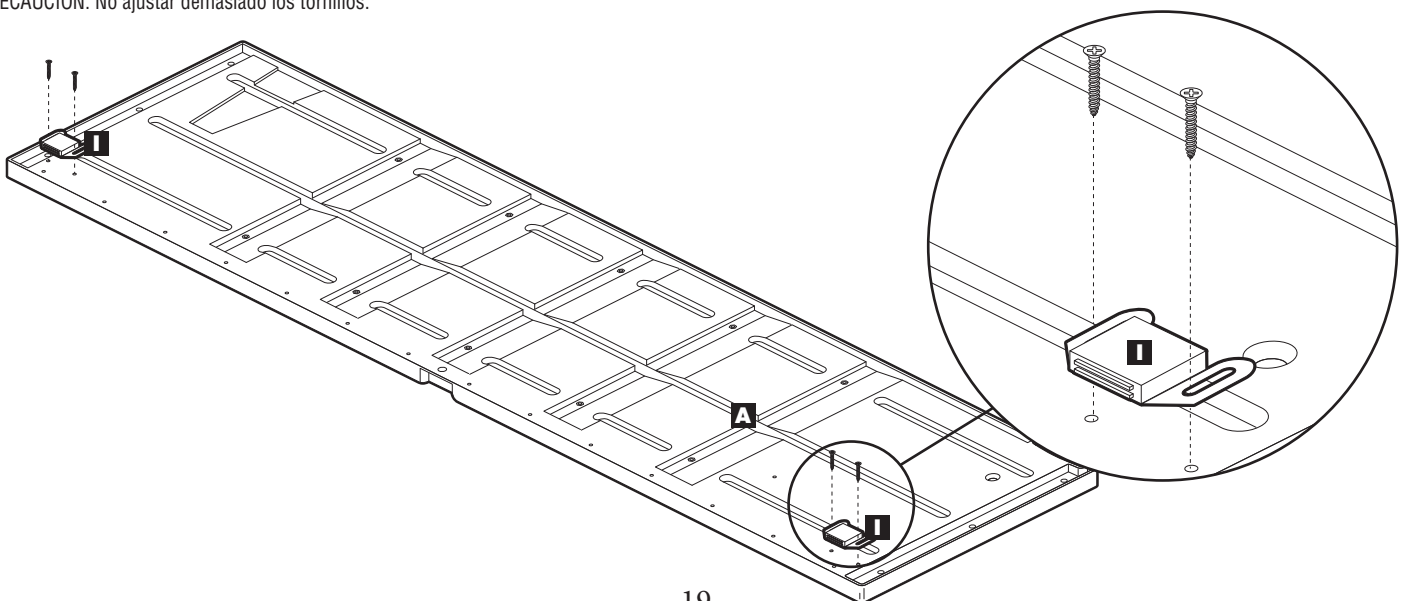

### PASO 3

#### INSTALAR EL PANEL SUPERIOR EN EL PANEL LATERAL

Con el panel de la puerta en posición plana, mover el panel lateral (B) a una posición vertical. Colocar el panel superior (D) en la ranura del panel lateral y alinear.

Utilizar tres tornillos de panel lateral (K) e instalar en el orden que se indica.

PRECAUCIÓN: No ajustar demasiado los tornillos.

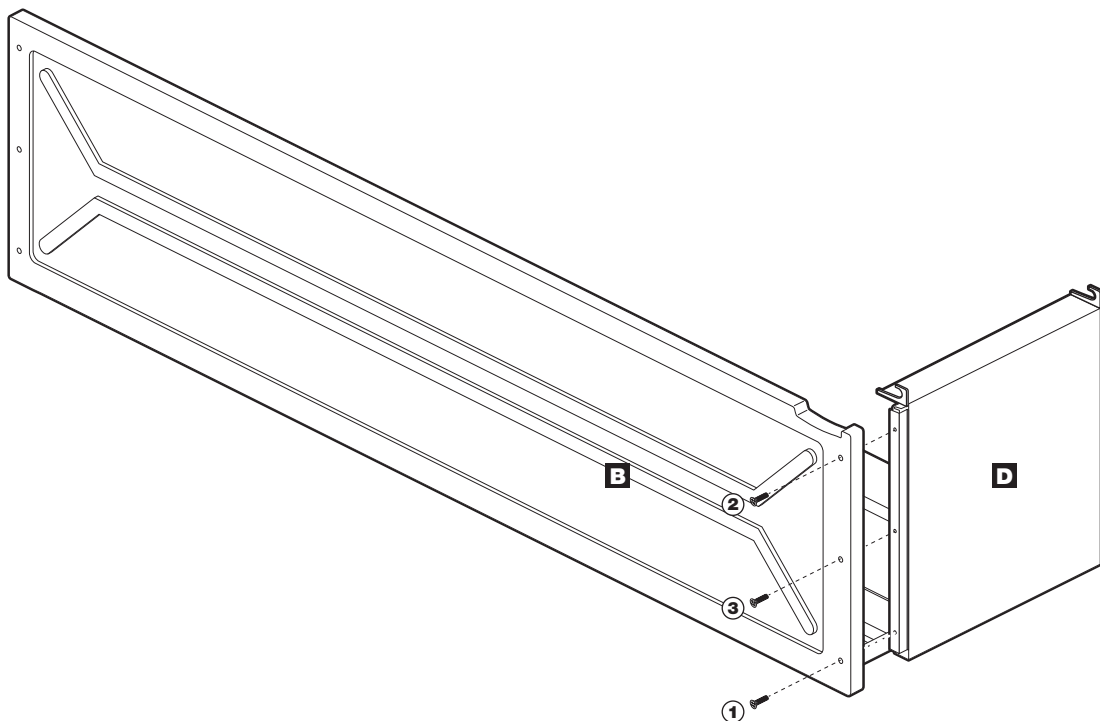

### PASO 4

#### INSTALAR EL PANEL INFERIOR EN EL PANEL LATERAL

Colocar el panel inferior (E) en la ranura del panel lateral y alinear.

Utilizar tres tornillos de panel lateral (K) e instalar en el orden que se indica.

PRECAUCIÓN: No ajustar demasiado los tornillos.

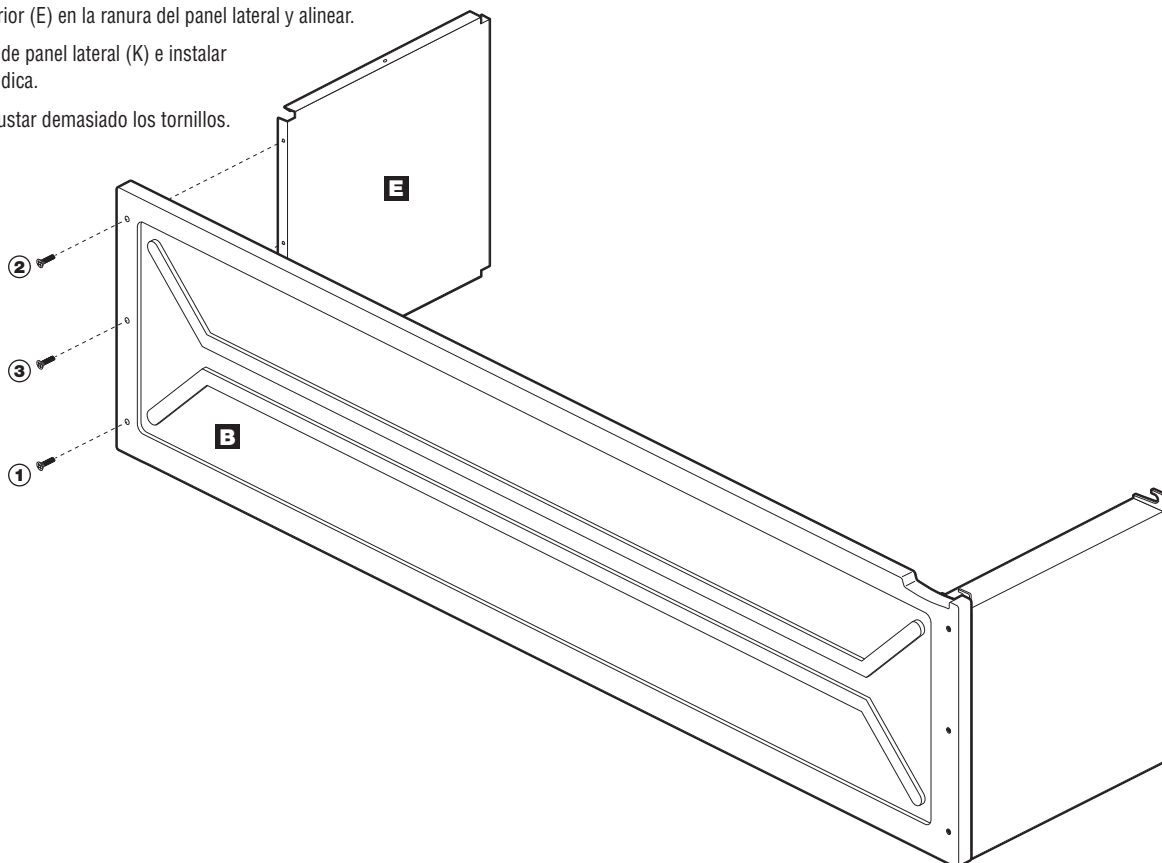

## PASO 5

### INSTALAR EL PANEL LATERAL RESTANTE EN EL PANEL INFERIOR Y PANEL SUPERIOR

Colocar el panel superior (D) y el panel inferior (E) en las ranuras del panel lateral (A) y alinear.

Utilizar seis tornillos de panel lateral (K) e instalar en el orden que se indica.

**PRECAUCIÓN:**  
No ajustar demasiado los tornillos.

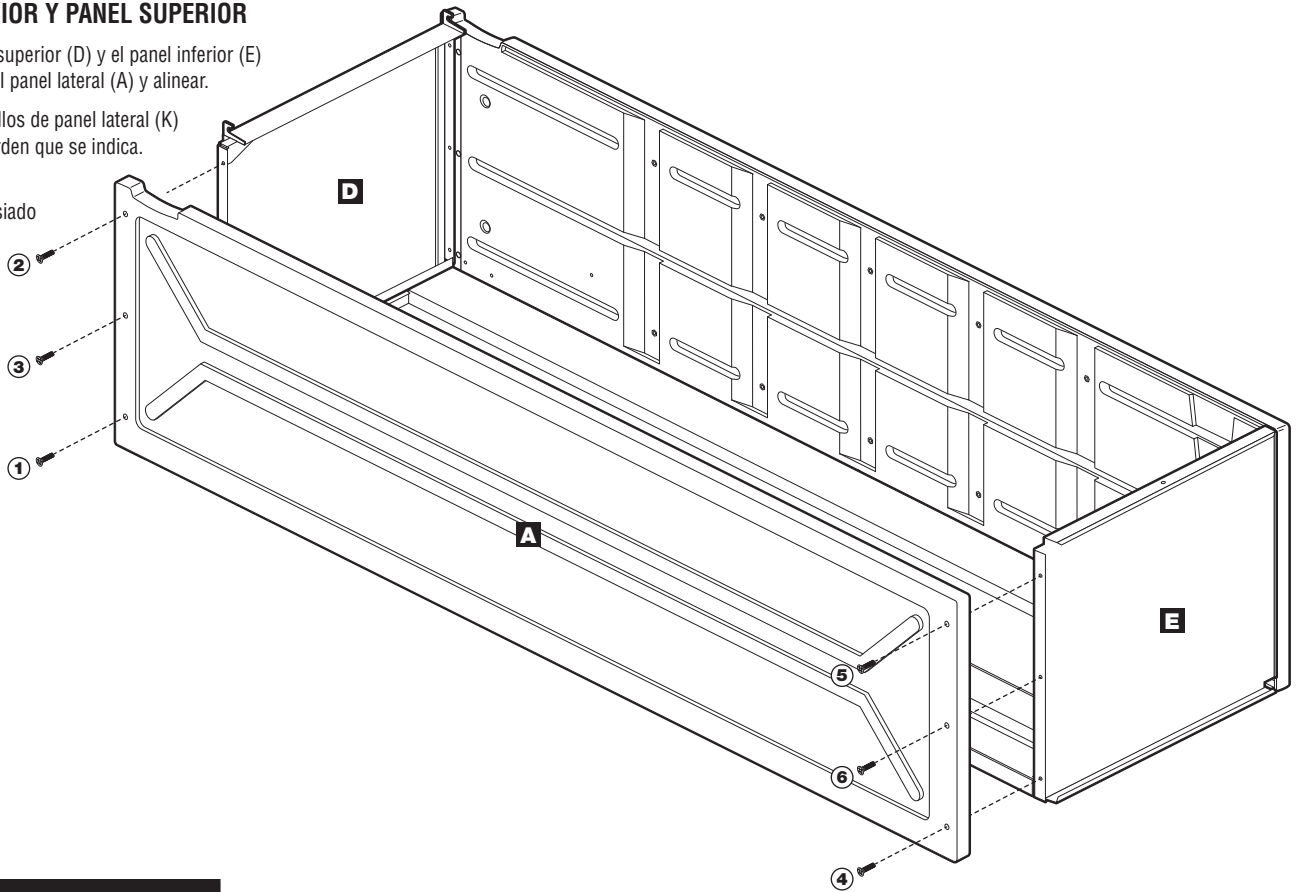

## PASO 6

### INSTALAR PANEL POSTERIOR

Colocar la unidad en posición vertical.

1. Colocar el panel posterior (G) en la ranura posterior del panel lateral izquierdo y mantener en su lugar.
2. Empujar el costado derecho del panel posterior en la ranura de la parte trasera del panel derecho.

**NOTA:** El panel posterior se doblará hasta encajar en la ranura de la parte posterior.

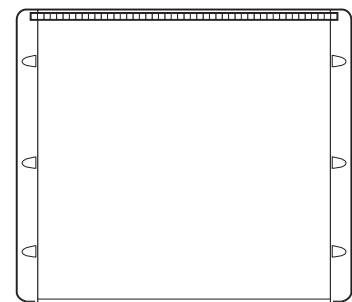
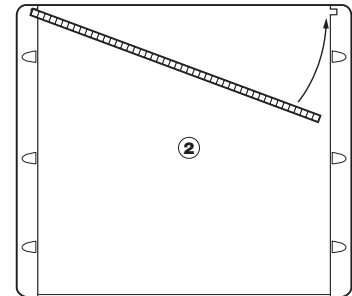
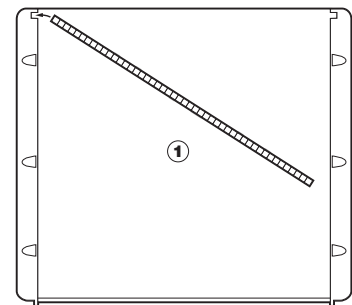
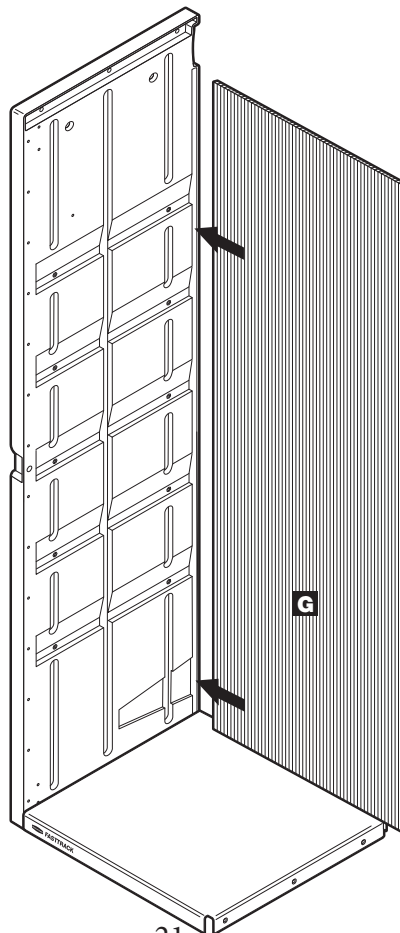

## PASO 7

### INSTALAR ESTANTE

CONSEJO: Usar un destornillador de punta magnética.

Inclinar el armario hacia un lado, con el lado de la bisagra hacia abajo y abrir la puerta.

Colocar el estante (F) en cualquiera de las posiciones de armado que se proporcionan.

NOTA: El orificio ranurado debe orientarse hacia la parte posterior de la unidad y el orificio redondo debe estar orientado hacia la parte frontal de la unidad.

Para fijar el estante (F), insertar cuatro tornillos para estantes (L) en las tuercas moldeadas de los paneles laterales.

1. Alinear y colocar los tornillos frontales.
2. Alinear y colocar los tornillos de la parte posterior.

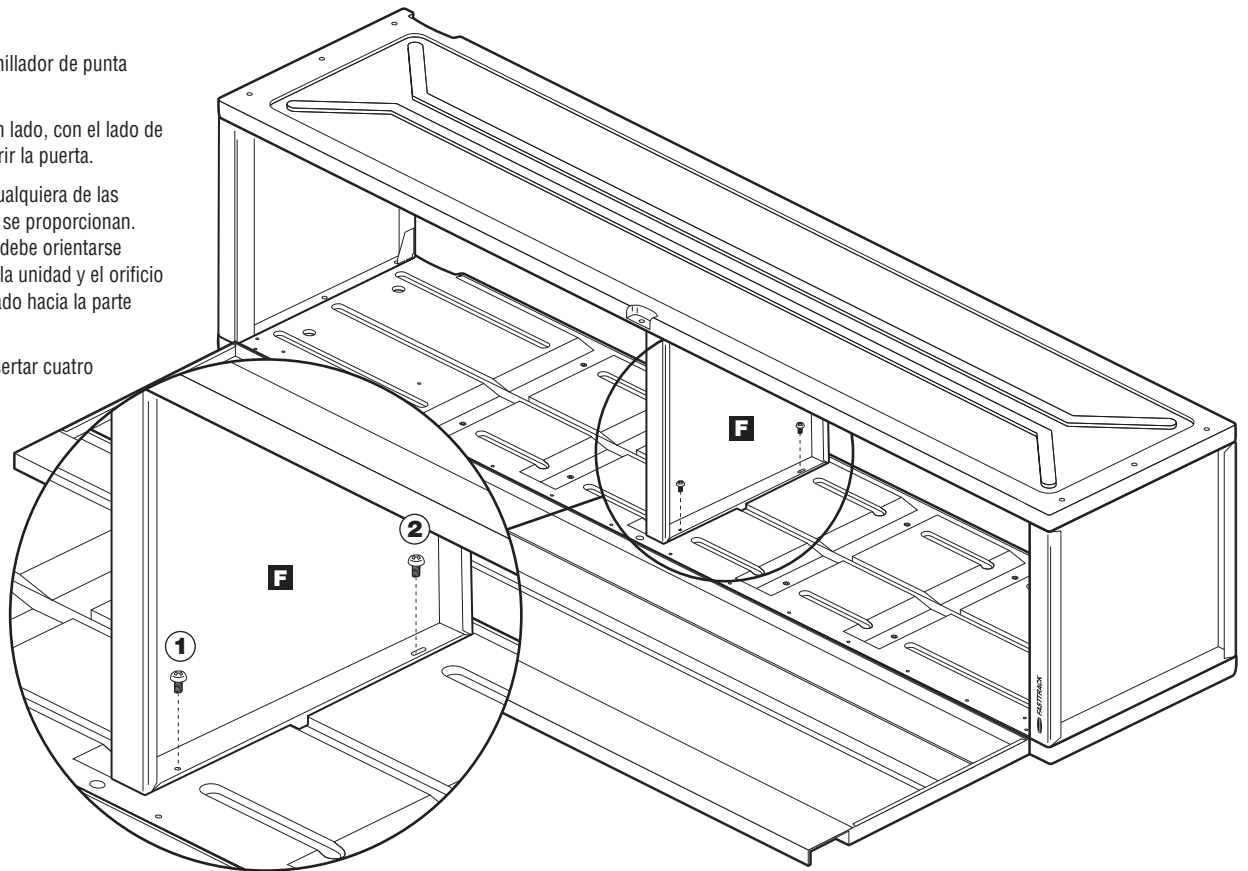

## PASO 8

### INSTALACIÓN DEL ARMARIO EN EL RIEL

NOTA: El riel FastTrack se vende por separado.

Colocar la unidad en el riel en la ubicación deseada.

Las pestañas en la parte trasera del panel superior se «enganchan» en el riel.

NOTA: Asegurarse de que el riel FastTrack se instale según las instrucciones y el nivel.

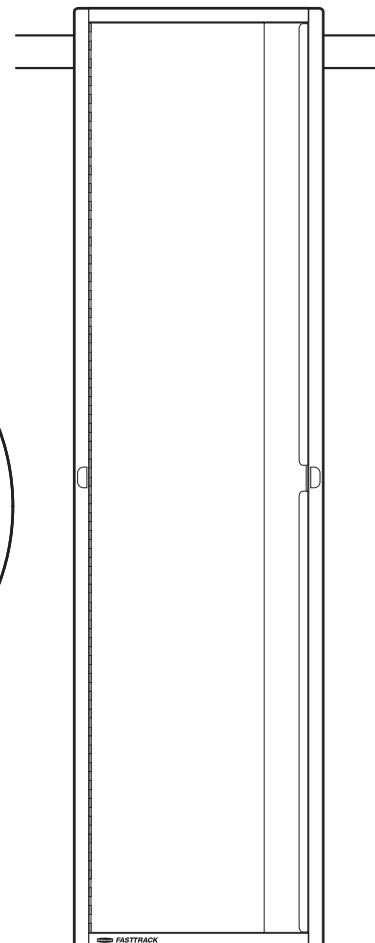
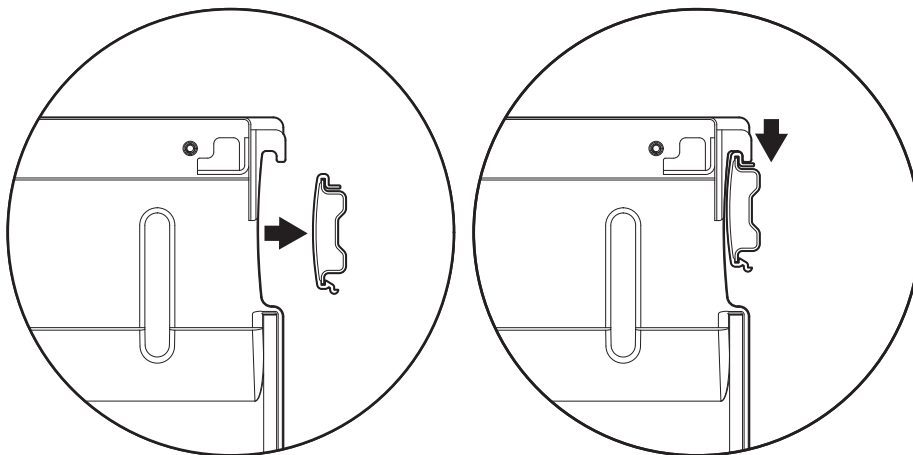

## PASO 9

### PREPARAR PARA EL MONTAJE DEL GABINETE

Marcar la ubicación del orificio en la parte posterior del panel inferior  
(Ubicado debajo del panel inferior).

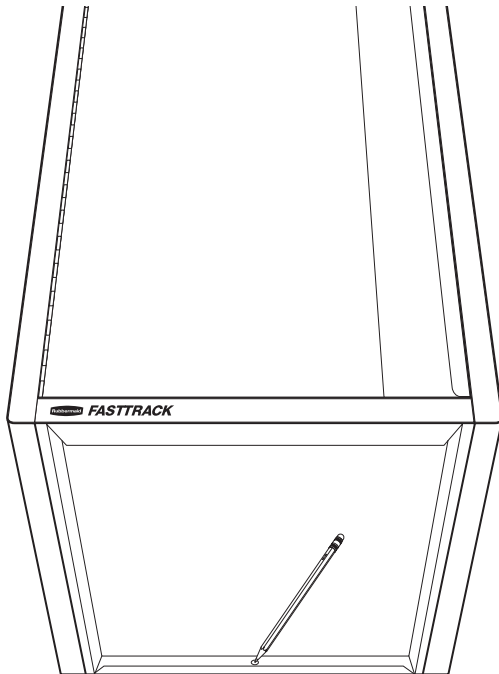

### ALTERNAR LOS PUNTOS DE ANCLAJE PARA EL ARMARIO INFERIOR

Si la parte de abajo del armario inferior está cerca del piso e impide el acceso razonable para instalar el montaje de pared y los tornillos debajo del panel inferior, se proporcionan dos ubicaciones alternativas cerca del extremo inferior, dentro de cada panel lateral.

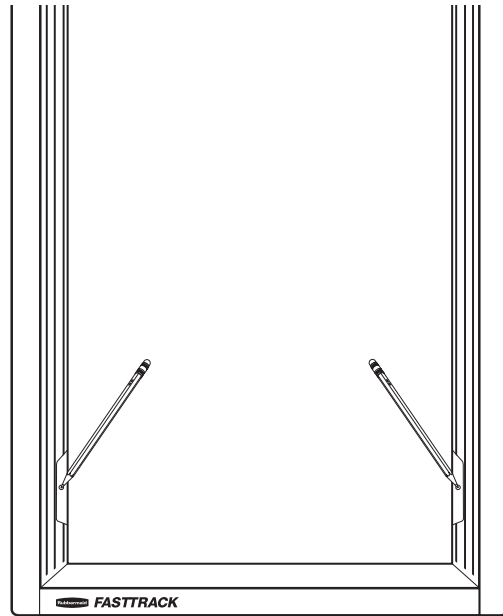

## PASO 10

### MONTAR EL GABINETE EN LA PARED

Sacar la unidad del riel e instalar el anclaje de pared (M) con una broca de 5/16", o perforar un orificio guía de 1/8" si se alinea un taco con la ubicación.

Volver a colocar la unidad en el riel y alinear el orificio con el anclaje de pared (M) o con el orificio guía.

Colocar el tornillo del anclaje (N) en el anclaje de pared o en el orificio guía.

PRECAUCIÓN: No ajustar demasiado los tornillos.

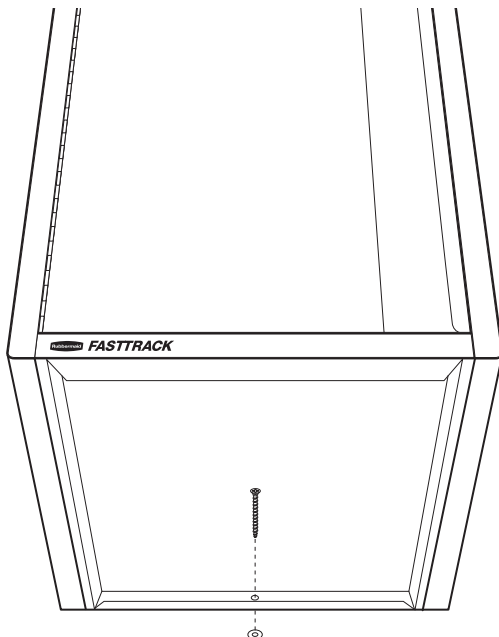

### ALTERNAR LOS PUNTOS DE ANCLAJE PARA EL ARMARIO INFERIOR

Sacar la unidad del riel e instalar los anclajes de pared (M) con una broca de 5/16", o perforar un orificio guía de 1/8" si se alinea un taco con la ubicación.

Volver a colocar la unidad en el riel y alinear el orificio con el anclaje de pared (M).

Colocar el tornillo del anclaje (N) en el anclaje de pared o en el orificio guía.

PRECAUCIÓN: No ajustar demasiado los tornillos.

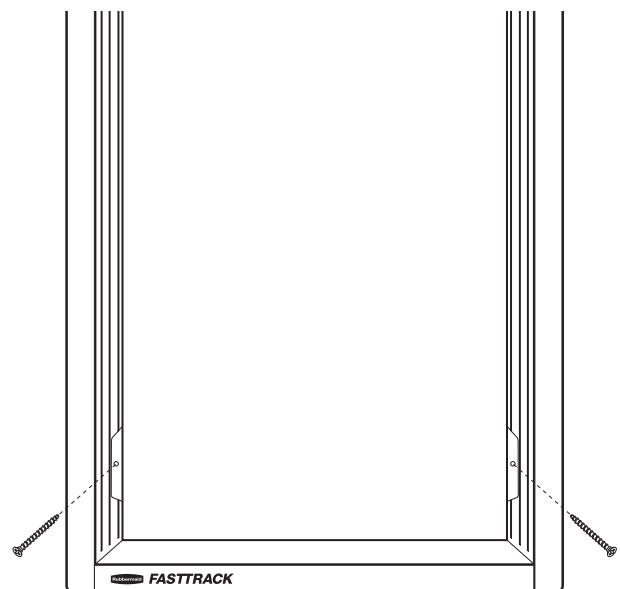

**CUADRAR EL GABINETE**

Ajustar la parte superior de la unidad hacia la izquierda o la derecha según sea necesario para cuadrar la puerta (golpear cualquiera de los laterales cerca del riel en la parte superior y posterior).

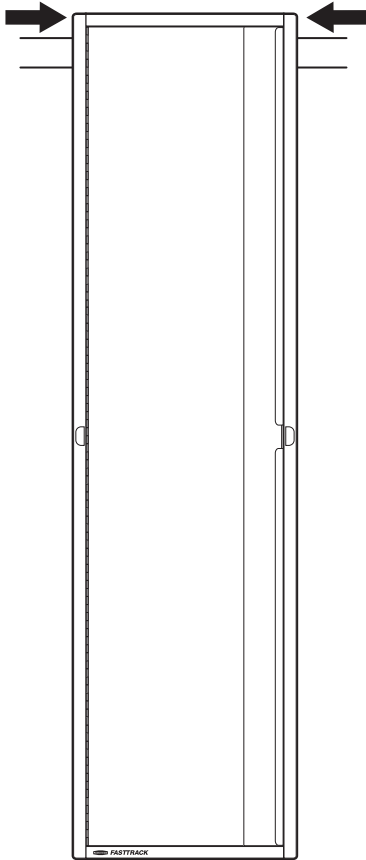
**MONTAR EL GABINETE EN LA PARED**

Instalar las sujeciones del soporte (O) en la parte posterior de cada panel lateral, justo debajo del riel. Utilizar un tornillo de sujeción de soporte (H) por lateral.

PRECAUCIÓN: No ajustar demasiado los tornillos.

