



SNUGRIDE[®] 35
INFANT CAR SEAT



Read This Instruction Manual

Do not install or use this child restraint until you read and understand the instructions in this manual.

FAILURE TO PROPERLY USE THIS CHILD RESTRAINT INCREASES THE RISK OF SERIOUS INJURY OR DEATH IN A SUDDEN STOP OR CRASH.

KEEP INSTRUCTIONS FOR FUTURE USE.

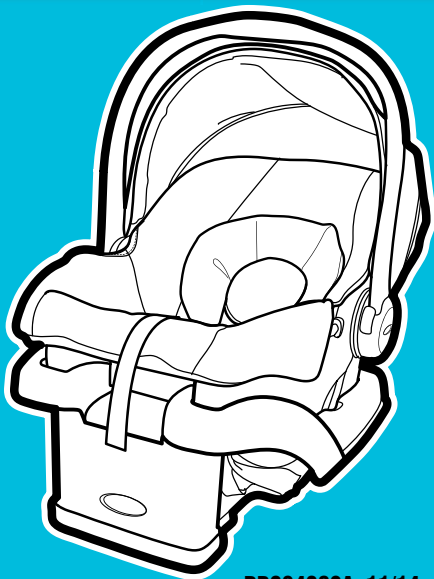

www.gracobaby.com

PD284963A 11/14

Important

Pages 4-13

- 1-A Quick Guide to Your Manual**
- 1-B Before You Begin**
- 1-C Safety Warnings**

Features

Pages 14-23

- 2-A Car Seat Features**
- 2-B Remove Car Seat from Base**
- 2-C Attach Car Seat to Base**
- 2-D Adjusting Carry Handle**
- 2-E Recline the Base**
- 2-F Choosing Vehicle Seat Location**
- 2-G Choosing LATCH or Seat Belt**
- 2-H What Is LATCH**

Rear-Facing Use

Pages 24-42

- 3-A Rear-Facing Checklist**
- 3-B Install With Base With LATCH Strap**
- 3-C Install With Base With Vehicle Seat Belt**
- 3-D Install Without Base With Vehicle Seat Belt**

Securing Child

Pages 43-54

- 4-A Adjust Harness to Fit Child**
- 4-B Adjust Buckle to Fit Child**
- 4-C Securing Child in Car Seat**
- 4-D Removing Child**

Carrier Use

Pages 55-56

Vehicle Information

Pages 57-67

- 6-A Additional LATCH Information**
- 6-B How to Remove LATCH**
- 6-C Unsafe Vehicle Seats**
- 6-D Vehicle Seat Belts**

Accessories

Page 68

Care & Cleaning

Pages 69-73

- 8-A Cleaning Seat Pad**
- 8-B Cleaning Buckle**



1-A Quick Guide to Your Manual

This car seat is for children 4-35 lb (1.8-16 kg) and 32" (81 cm) or less.

Get to Know Your Car Seat

Review section 2-A to see all of the features of this infant car seat.

What Seating Location Should I Use?

The best seating location for this infant car seat is one that:

- Is recommended by your vehicle owner's manual, and
- Results in a secure installation of this car seat.



Never place a child rear-facing in a seating position with an active front air bag.

Review section 6 of this manual AND your vehicle owner's manual.

Which Installation Method Should I Use?

This infant car seat base can be installed in your vehicle using either the vehicle seat belt **OR** the LATCH system. Both are equally safe to use. **DO NOT USE BOTH AT THE SAME TIME.**

This infant car seat carrier can be installed in your vehicle using only the vehicle seat belt. LATCH is not available to install the carrier.

When Installing Base



LATCH System



LATCH consists of lower anchors, which are built-in to your vehicle, and connecting hooks that are built-in your car seat.

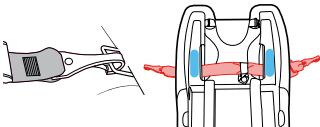

Review section 3-B of this manual AND your vehicle owner's manual.

Vehicle Seat Belt

There are two types of vehicle seat belts that can be used. Lap/Shoulder Seat Belt or Lap Only Seat Belt.

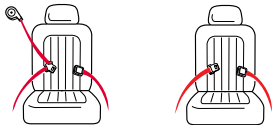

Review section 3-C of this manual AND your vehicle owner's manual.

When Installing Carrier



Vehicle Seat Belt

There are two types of vehicle seat belts that can be used. Lap/Shoulder Seat Belt or Lap Only Seat Belt.

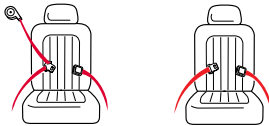

Review section 3-D of this manual AND your vehicle owner's manual.

Does Your Seat Fit Your Child Correctly?

To make sure your child is secured properly, review section 4 to understand all of the actions you need to take to properly adjust the car seat to fit your child.

You Need To Adjust:

Harness Height

Harness straps at or just below the child's shoulders. Review section 4-A.



Buckle Position

The correct slot is the one that is closest to your child without being underneath them. Review section 4-B.

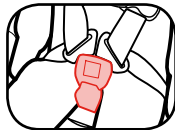

Harness Tightness

If your fingers slide off the harness straps without pinching the straps, it is tight enough. Review section 4-C.

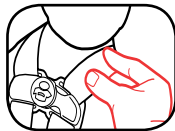

Did You Do Everything Correctly?

i
1 Important

Base or Car Seat Does Not Move More Than 1" (2.5 cm) At The Belt Path

Review section 3.



Car Seat Level to Ground

Review sections 2-E and 3.

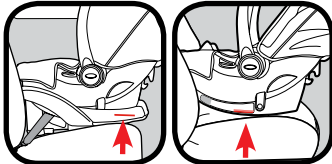

Car Seat Is Properly Attached To Base

Review section 2-C.

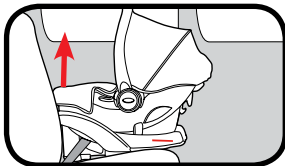

Cannot Pinch Harness

Harness straps at or just below the child's shoulders.

Review section 4-C.

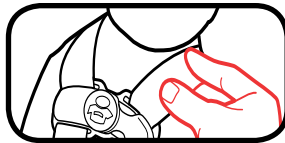

Chest Clip Even With Armpits

Review section 4-C.

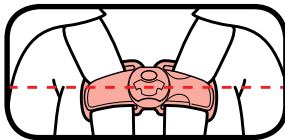



1-B Before You Begin

Your child's safety depends on you. No car seat can guarantee protection from injury in every situation, but proper use helps reduce the risk of serious injury or death.

Even if this car seat seems easy to figure out on your own, you must follow the detailed instructions in this instruction manual to ensure the steps below are performed correctly.

Register This Child Restraint

Please fill out the prepaid registration postcard attached to the harness and mail it in today **or register online at www.gracobaby.com/carseatregistration.**

Child restraints could be recalled for safety reasons. You must register this restraint to be reached in a recall. Send your name, address, and the restraint's model number and manufacturing date to:

Graco Children's Products, Inc.
Attn: Customer Service
3 Glenlake Parkway Atlanta, GA 30328
or call 1-800-345-4109
or register online at
www.gracobaby.com/carseatregistration

For recall information, call the U.S. Government's Vehicle Safety Hotline at 1-888-327-4236 (TTY: 1-800-424-9153), or go to <http://www.NHTSA.gov>.

For future reference or if you change addresses, record the model name, model number, date of manufacture, and purchase date of this car seat below. You can find this information either on the registration card if you still have it or on the date label located on the back of the car seat.

Model Name _____

Model Number _____

Date of Manufacture _____

Date of Purchase _____

If You Need Help

In the U.S.A, please contact our Customer Service Department with any questions you may have concerning parts, use, or maintenance. When you contact us, please have your product's model number and date of manufacture ready so that we may help you efficiently. These numbers can be found on a sticker on the back side of your car seat.

For additional resources or to get your car seat checked by a child passenger safety technician, please visit the following web sites:

www.nhtsa.gov • www.seatcheck.org • www.safekids.org



Certification

This child restraint meets or exceeds all applicable requirements of Federal Motor Vehicle Safety Standard 213 for use in motor vehicles.



This child restraint is certified for use in aircraft.

Contact the airline for their specific policies.

Car Seat's Useful Life

STOP using this car seat and throw it away 7 years after the date of manufacture. Look for date of manufacture label on back of the car seat.

Graco Children's Products Inc. advises against loaning or passing along a car seat unless you know the complete history of the product. We also advise against purchasing a car seat second hand.

Vehicle Seat Protection

Protect vehicle seat. Use a car seat mat, towel, or thin blanket under and behind car seat.

Warm Weather Use

Car seat parts can get very hot in the sun or warm weather. **To avoid burns, always check before putting child in car seat.**

1-C Safety Warnings

i
1 Important

No car seat can guarantee protection from injury in every situation, but proper use helps reduce the risk of serious injury or death. **READ THIS MANUAL CAREFULLY.**

! WARNING!

Failure to follow these instructions and child restraint's labels can result in child striking the vehicle's interior during a sudden stop or crash.



! NEVER PLACE THIS CHILD RESTRAINT REAR-FACING IN A VEHICLE SEATING LOCATION THAT HAS AN ACTIVE FRONT AIR BAG.

If an air bag inflates, it can hit the child and car seat with great force and cause serious injury or death to your child.

! Review your vehicle owner's manual for more information about air bags and car seat use.

! If your vehicle does not have a back seat, review your vehicle owner's manual.

! The American Academy of Pediatrics (AAP) and National Highway Traffic Safety Administration (NHTSA) recommend that children be rear-facing until age 2 or until they reach the maximum rear-facing height and weight rating for their seat.

! This child restraint must only be used with children weighing between 4-35 lb (1.8-16 kg).

! Select a suitable location for the car seat in your vehicle.

! Secure car seat with a vehicle seat belt or LATCH that is properly routed as shown in this manual.

! Vehicle seat belt system MUST hold car seat securely. Not all vehicle seat belts can be used with a car seat.

! If vehicle seat belt does not hold car seat securely, read "Vehicle Seat Belts" section 6 and your vehicle owner's manual.

! Always secure car seat with LATCH or a vehicle seat belt, even when unoccupied. In a crash, an unsecured car seat can injure passengers.

! DO NOT use car seat if it is damaged or missing parts.

! If car seat is in a crash, it must be replaced. DO NOT use it again! A crash can cause unseen damage and using it again could result in serious injury or death.

! DO NOT use accessories or parts other than those provided by Graco. Their use could alter the performance of the car seat.

! DO NOT remove LATCH system from car seat. If using vehicle seat belt to secure car seat, LATCH connectors must be stored.

! Never leave child unattended, even when sleeping. Child may become tangled in harness straps and suffocate or strangle.

! Rear-facing car seat must be properly leveled:

- Too reclined can result in injury or ejection.
- Too upright can result in breathing difficulties.



! Never attach two LATCH connectors to one vehicle lower anchor point unless specifically allowed by the vehicle manufacturer.

! Do not use both the vehicle seat belt and LATCH strap at the same time when using the car seat rear-facing.

2-A Car Seat Features

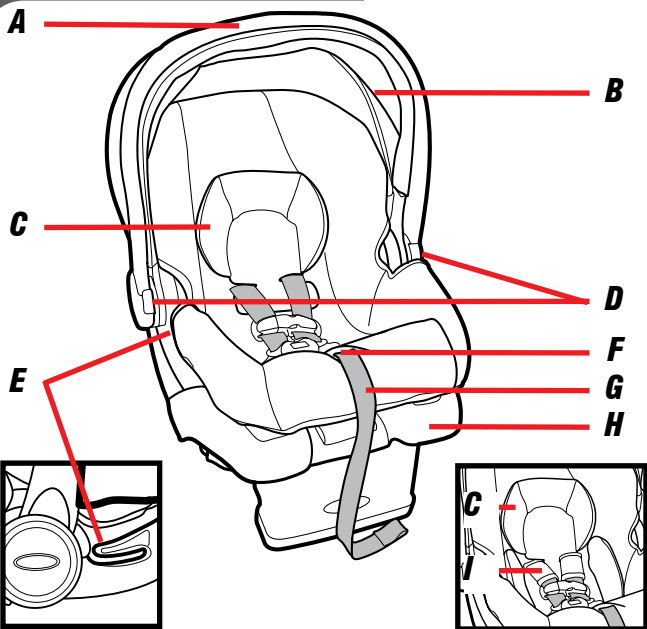

- A** Carry Handle
- B** Canopy
- C** Head Pillow (Select models)
- D** Handle Adjustment Buttons
- E** Rear-Facing Belt Path
(When Used Without Base)

- F** Harness Release
Lever (Under Pad)
- G** Harness Adjustment
Strap
- H** Removable Base
- I** Harness Covers
(Select Models)

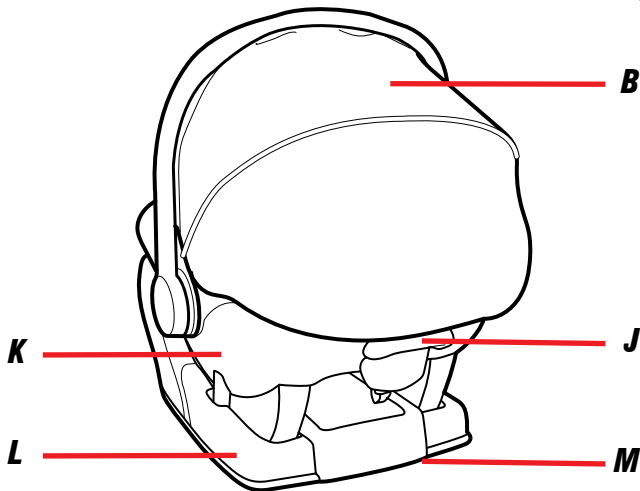

- J Base Release Lever**
- K Car Seat**
- L Level to Ground Line**
- M Instruction Manual Storage (Under Base)**
- N Chest Clip**
- O Harness Straps**
- P Buckle Tongues**
- Q Buckle**
- R Buckle Strap**

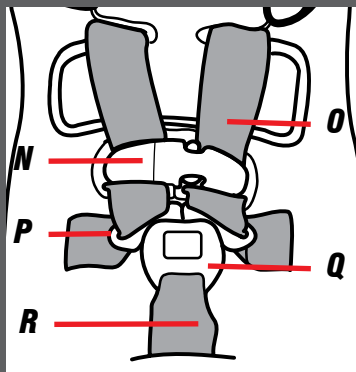

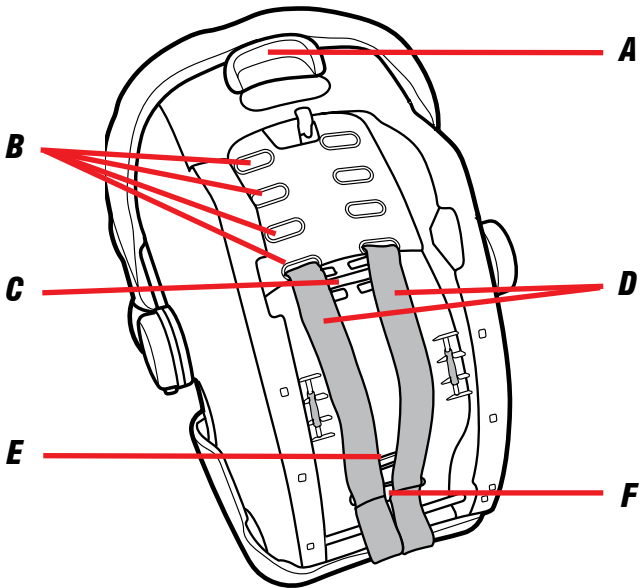

- A** *Base Release Lever*
- B** *Harness Strap Slots*
- C** *Locking Clip*
- D** *Harness Straps*
- E** *Buckle Metal Clip*
- F** *Splitter Plate*

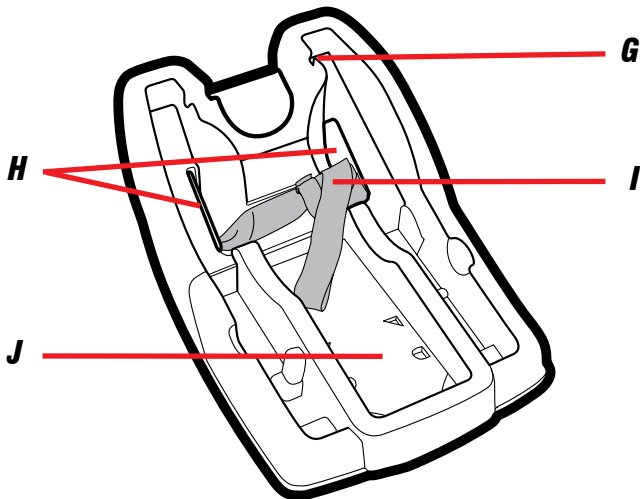

- G** Car Seat Base Lock
- H** Base Rear-Facing Belt Path
- I** LATCH Strap
- J** Instruction Manual Storage (Under Base)
- K** LATCH Storage
- L** Base Recline Wedge

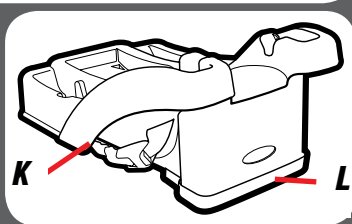

2-B Remove Car Seat from Base

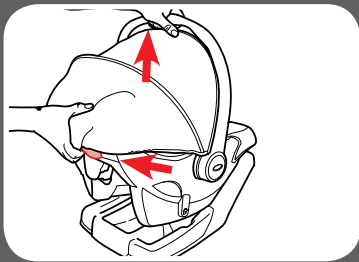

1. *To Remove Car Seat from Base*

From the back of the car seat, squeeze the base release handle and lift the car seat out of the base.

2-C Attach Car Seat to Base

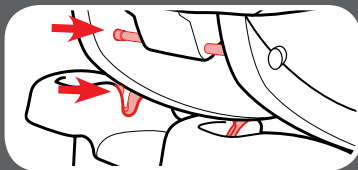

2. *Attaching Car Seat To Base*

Align the locking bar at the front of the car seat with the locks in the base. Set car seat in the base. Push down on the front of the car seat. You will hear a “click” when it is locked.

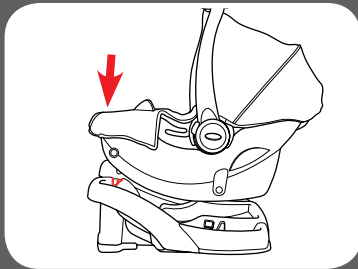

Pull up on the front corners of the seat to make sure it is locked.

2-D Adjusting Carry Handle

1. To Rotate Handle

Press the red handle adjustment buttons on both sides of handle.

MAKE SURE handle locks into position before lifting the carrier.

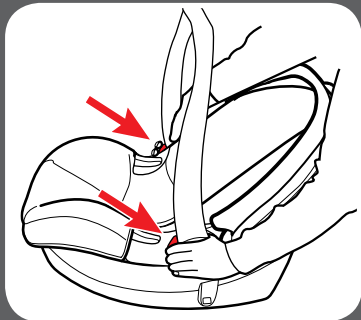

2. Handle Has 4 Positions

Rotate handle to any of the 4 locked positions. Push and pull the handle to make sure handle is in a lock position.

Carry handle **MUST** be upright in position A when carrying.

Handle can be in any position when used in the vehicle.

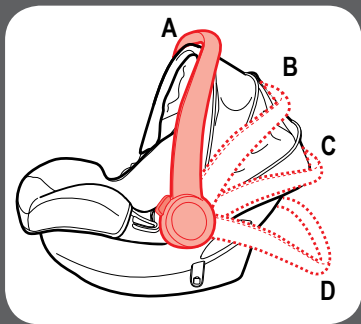

2-E Recline the Base

1

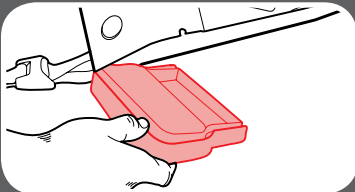
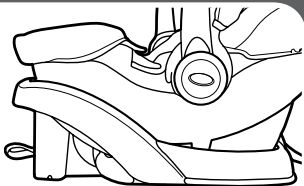

2

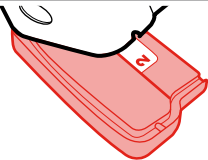
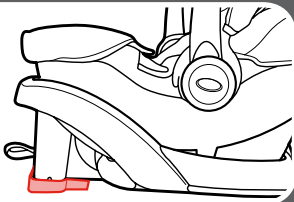

1. Base Has 3 Recline Positions

Position 1 is the least reclined position. Remove the base wedge.

For position 2, attach the base wedge with the label marked 2 facing up.

For position 3, attach the base wedge with the label marked 3 facing up.

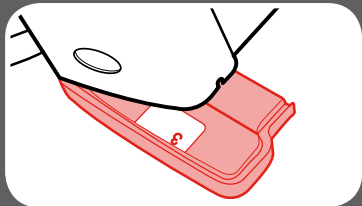
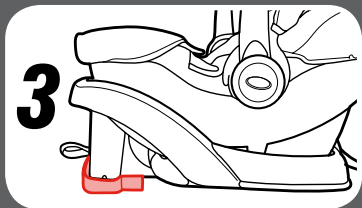

If needed, rolled towels may be placed under the base, at the vehicle seat crease, until the level line is level with the ground.

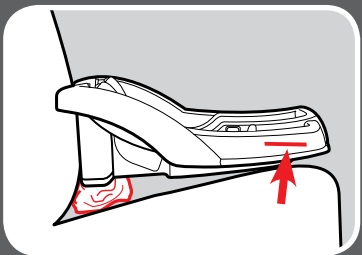

2-F Choosing Vehicle Seat Location

Review your vehicle owner's manual for seating locations. Review section 6 for additional information.

Some vehicles have specific requirements for where the car seat can be installed. Be sure to check your vehicle owner's manual for all available seating positions.

According to accident statistics, the safest place for your child in any vehicle is the back seat. The center of the back seat can be the safest during a possible side impact.



!WARNING!



NEVER place this child restraint rear-facing in a vehicle seating location that has an active front air bag.

In the event there is no back seat, review your vehicle owner's manual to see how to use your infant child restraint.

2-G Choosing LATCH or Seat Belts

This car seat can be installed in your vehicle using either the vehicle seat belt OR the LATCH system. Both systems are equally safe to use. **DO NOT USE BOTH AT THE SAME TIME.** Review section 6 for additional information.

2-H What is LATCH?

LATCH consists of lower anchors, which are built-in to your vehicle, and connecting hooks that are built-in to your car seat. Lower anchors are used **INSTEAD** of the vehicle's seat belt to secure the child seat to the vehicle.

Review your vehicle's owner manual for exact location and use. Review section 6 for additional information.

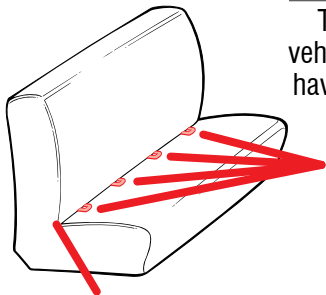

Vehicle Seat Crease

Typical seat in a passenger vehicle. Other vehicle types may have different LATCH locations.

Vehicle Lower Anchor Points

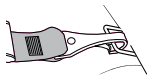

3-A Rear-Facing Safe Use Checklist

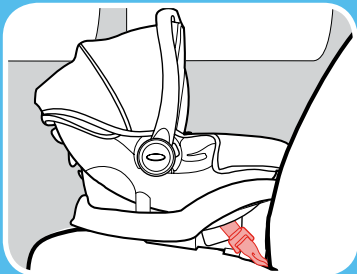

LATCH Strap

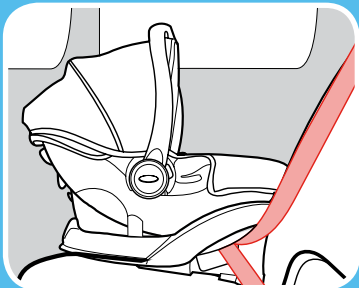

Vehicle Lap/Shoulder Seat Belt

Rear-Facing:
4-35 lb (1.8-16 kg)
32" (81 cm) or less

- Car seat **MUST** be rear-facing in the vehicle back seat.
- Make sure LATCH strap or vehicle seat belt is routed through the rear-facing belt path, marked with a blue label.
- Install this car seat tightly in your vehicle. Car seat **should not move** at the belt path more than 1" (2.5 cm) from side to side and front to back.
- Check the level line to make sure the line is level with the ground.



- Harness straps must be **at or just below** the top of child's shoulders and chest clip must be at **armpit level**.

Note: Preterm or low birth weight infants may be at special risk in a vehicle or aircraft. According to the AAP, these infants may suffer breathing issues if improperly reclined in a car seat. Use the corrected age for preemies. Graco advises that you have your physician or hospital staff evaluate your infant and recommend the proper car seat or car bed before you and your infant leave the hospital.

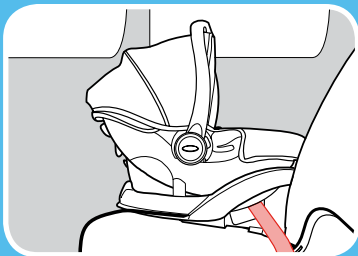

Vehicle Lap Only Seat Belt

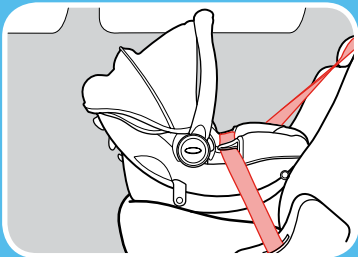

Vehicle Lap/Shoulder Seat Belt Without Base

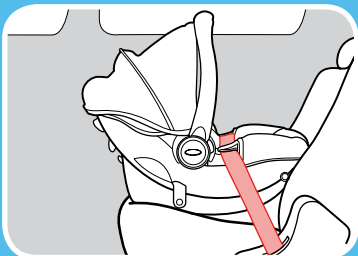

Vehicle Lap Only Seat Belt Without Base

! WARNING!



**NEVER
place this
child
restraint**

**rear-facing in a
vehicle seating
location that has an
active front air bag.**



**3 Rear
Facing**

3-B Install With Base Rear-Facing With LATCH Strap

Review your vehicle's owner manual for LATCH location and use.

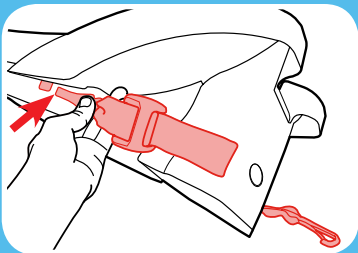

1. Remove LATCH Hooks from Storage Location

Slide each LATCH hook out of the storage location.

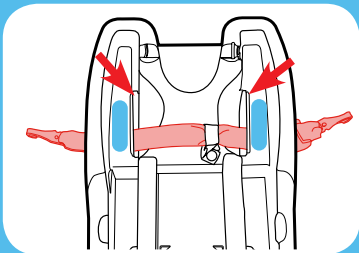

2. Make Sure LATCH Strap is in the Rear-Facing Belt Path, Marked With a Blue Label



3. Extend the LATCH Strap

Extend the LATCH strap to its maximum length by pressing the gray button and pulling on the strap.

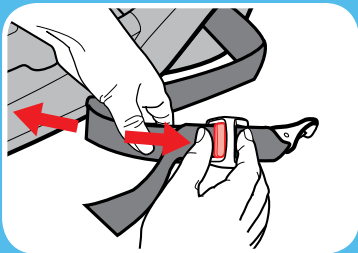

4. Place Base in Back Seat of the Vehicle

Place the base flat on the vehicle seat. Push it back until the front of the base touches the vehicle seat back. Center the base between the lower LATCH anchors.

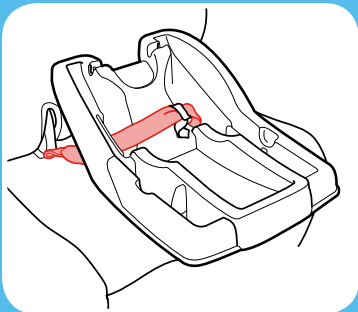

**3 Rear
Facing**

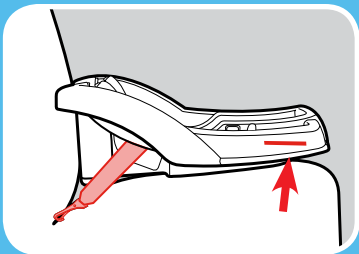

5. **Check the Rear Facing Level Line**

The red level line on the side of the seat **MUST BE LEVEL** with the ground.

To recline, review section 2-E.

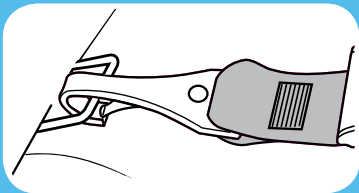

6. **Connect LATCH Hooks to Vehicle's Lower LATCH Anchors**

LATCH strap should lay as flat as possible and not be twisted.

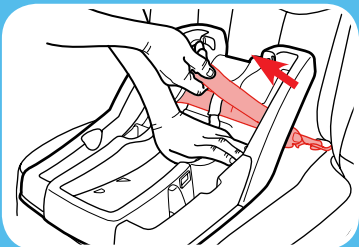

7. **Tighten the LATCH Strap**

Press down firmly in the center of the base while tightening the LATCH strap.



8. Test For Tightness

Grab the sides of the base where the LATCH strap is and push and pull the base from side to side and front to back.

If the base moves less than 1" (2.5 cm), it is tight enough.



9. Attach Car Seat to Base

Place car seat into the base. Push down on the front of the car seat and handle until you hear a “click”.

Test to make sure the car seat is attached by pulling up on the front corners of car seat.

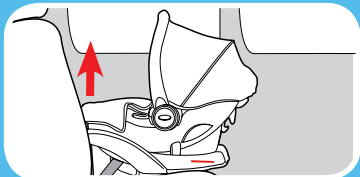
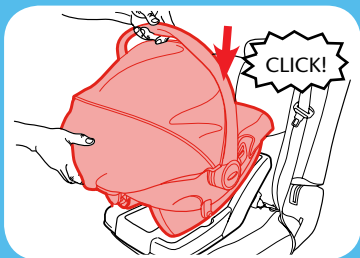

3 Rear
Facing

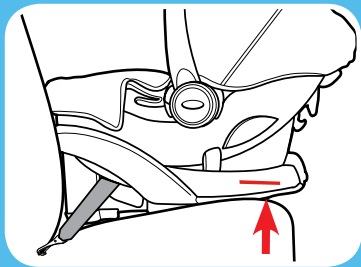

10. Check the Rear Facing Level Line

The red level line on the side of the seat **MUST BE LEVEL** with the ground.

Check the level line with child in the child restraint when making sure the line is level with the ground.

See section 4-C to secure your child.

Is Everything Correct?

**Base Does Not Move
More Than 1" (2.5 cm)
At The Belt Path**



**Car Seat Is Properly
Attached To Base**

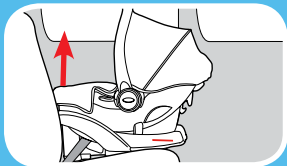

**Car Seat Level to
Ground**

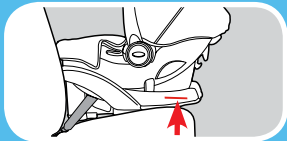

Cannot Pinch Harness



**Chest Clip Even With
Armpits**

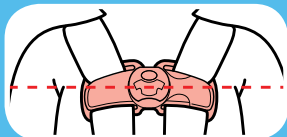

3-C Install With Base Rear-Facing With Vehicle Seat Belt

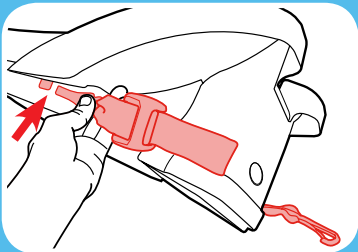

1. Store LATCH Straps

Hook the LATCH hooks into the holes on side of base as shown. Remove the slack.



2. Place Base in Back Seat of the Vehicle

Place the base flat on the vehicle seat. Push it back until the front of the base touches the vehicle seat back.



3. Check the Rear Facing Level Line

The red level line on the side of the seat **MUST BE LEVEL** with the ground.

To recline, review section 2-E.

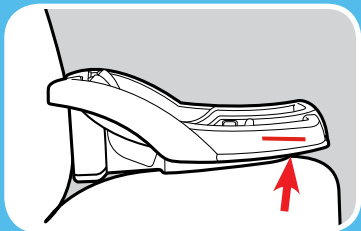

Review your vehicle's owner manual for vehicle seat belt use

4. Route the Vehicle Seat Belt

Thread vehicle seat belt through the rear-facing belt path (marked with a blue label) and buckle it. The seat belt should lay as flat as possible and not be twisted.

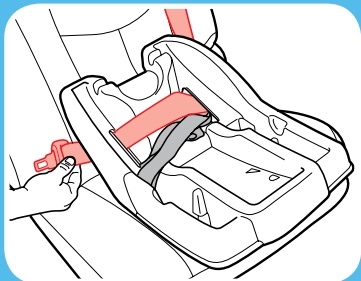



3 Rear
Facing



5. **Lock the Vehicle Seat Belt**

In most vehicles today, **slowly pull the shoulder belt all the way out** and then let it go back in. You will hear a “clicking” sound. Slowly pull out on the belt and it should be locked. If not, review your car’s owner manual and section 6-D.



6. **Tighten the Vehicle Seat Belt**

Press down firmly in the center of the base. Pull on the shoulder belt to tighten while feeding the slack back in the retractor.

7. Test For Tightness

Grab the sides of the base where the seat belt is and push and pull the base from side to side and front to back.

If the base moves less than 1" (2.5 cm), it is tight enough.

8. Attach Car Seat to Base

Place car seat into the base. Push down on the front of the car seat and handle until you hear a "click".

Test to make sure the car seat is attached by pulling up on the front corners of car seat.

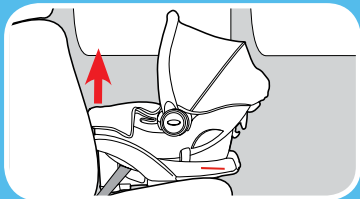
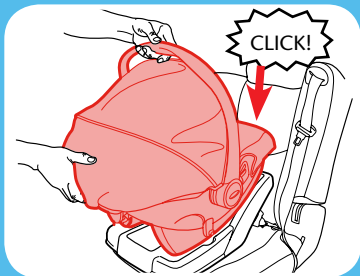

3 Rear
Facing

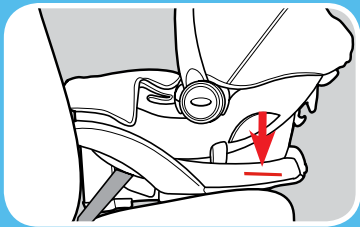

9. ***Check the Rear Facing Level Line***

The red level line on the side of the seat **MUST BE LEVEL** with the ground.

Check the level line with child in the child restraint when making sure the line is level with the ground.

See section 4-C to secure your child.

Is Everything Correct?

Base Does Not Move
More Than 1" (2.5 cm)
At The Belt Path



Car Seat Is Properly
Attached To Base

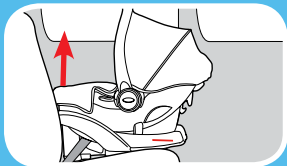

Car Seat Level to
Ground

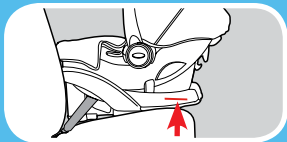

Cannot Pinch Harness



Chest Clip Even With
Armpits

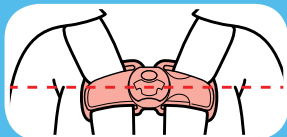

3-D Install Without Base Rear-Facing With Vehicle Seat Belt

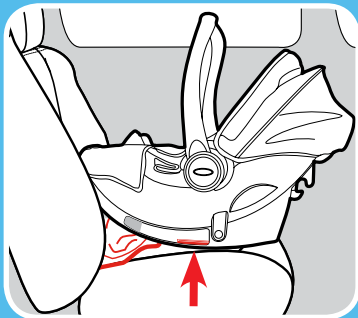
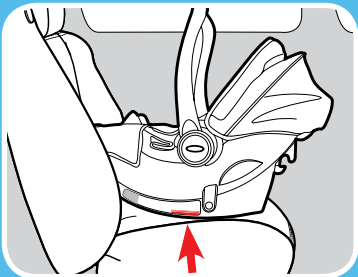

1. *Place Car Seat in Back Seat of the Vehicle*

Place the car seat on the vehicle seat. Push it back until the front of the car seat touches the vehicle seat back.

Check the rear-facing level line. The red level line on the side of the seat **MUST BE LEVEL** with the ground.

If needed, rolled towels may be placed under the base, at the vehicle seat crease, until the level line is level with the ground.



2. Route the Vehicle Seat Belt

Thread vehicle seat belt through the rear-facing belt path (marked with a blue label) and buckle it. The seat belt should not be twisted.

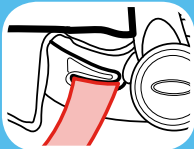
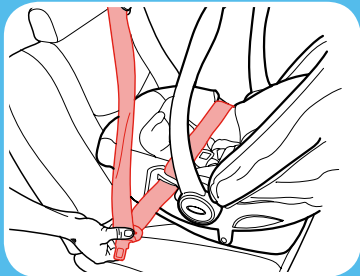

3. Lock the Vehicle Seat Belt

In most vehicles today, **slowly pull the shoulder belt all the way out** and then let it go back in. You will hear a “clicking” sound. Slowly pull out on the belt and it should be locked. If not, review your car’s owner manual and section 6-D.

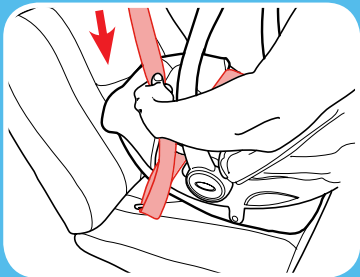

3 Rear
Facing

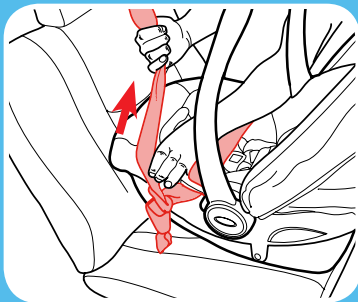

4. Tighten the Vehicle Seat Belt

Lay your forearm across the car seat **at the belt path and push down**. Pull on the shoulder belt to tighten while feeding the slack back in the retractor.

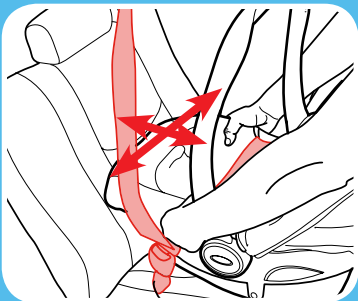

5. Test For Tightness

Grab the sides of the car seat where the seat belt is and push and pull the car seat from side to side and front to back.

If the car seat moves less than 1" (2.5 cm), it is tight enough.



6. Check the Rear Facing Level Line

The red level line on the side of the seat **MUST BE LEVEL** with the ground.

Check the level line with child in the child restraint when making sure the line is level with the ground.

If needed, rolled towels may be placed under the car seat, at the vehicle seat crease, until the level line is level with the ground.

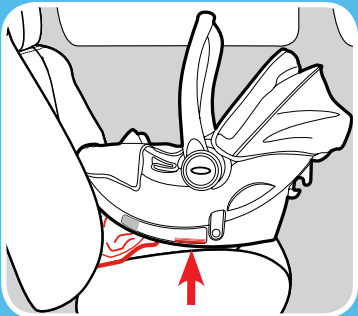
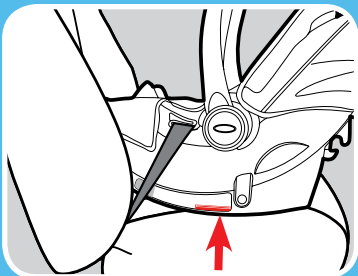

3 Rear
Facing

Is Everything Correct?

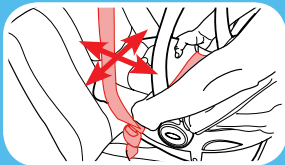

Car Seat Does Not Move More Than 1” (2.5 cm) At The Belt Path

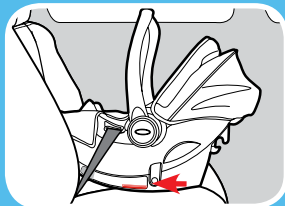

Car Seat Level to Ground



Cannot Pinch Harness

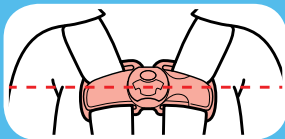

Chest Clip Even With Armpits



3 Rear Facing



4-A Adjust Harness to Fit Child

1. Loosen Harness Straps

Push down on the harness release lever while pulling out on the harness straps at the chest clip.

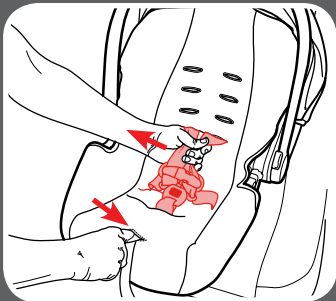

2. Release the Chest Clip

Squeeze the chest clip release buttons and pull apart.

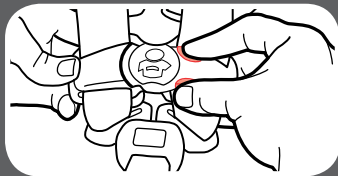



3. Unbuckle the Buckle

Press the red button and pull buckle tongues out. Place harness straps off to the sides.

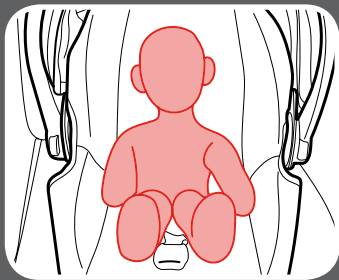

4. Place Your Child in the Seat

Make sure their back is flat against the car seat back.

Avoid bulky or heavy clothing when it is cold out. Doing so will prevent the harness straps from tightening properly. If needed, place a blanket over the child after you have secured them.

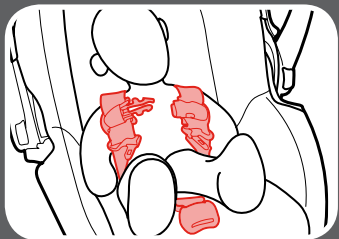

5. Place Harness Straps Over Child's Shoulders

6. Check Harness Height

Harness Straps
**MUST BE AT OR
JUST BELOW** the
Child's Shoulders

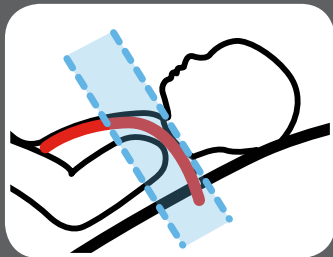
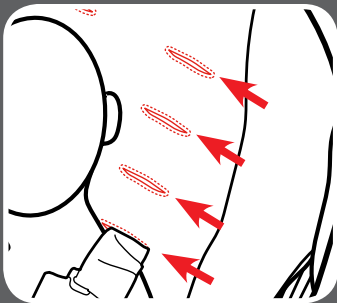

7. Top of Head **MUST
BE AT LEAST 1"**
(2.5 cm) BELOW
the Top of the Car
Seat

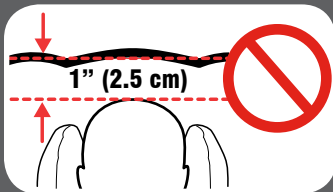

4 Securing
Child

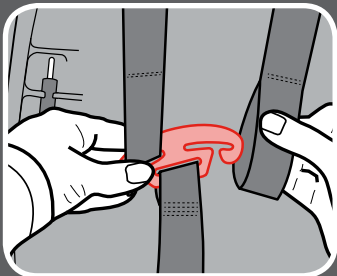

8. To Change Harness Height Positions

With harness straps loose, from the back of the car seat, remove the harness straps loops from the splitter plate.



9. Pull Harness Straps Out From the Front of Car Seat

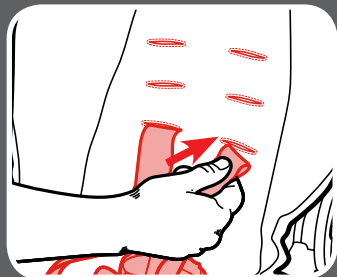

10. Insert Harness Strap Into the New Location

Make sure harness straps are not twisted and are at the same height.

11. For Smaller Baby

If the child's shoulders are even with or just below the lowest 2 slots, use the upper loops on the harness straps.

Thread the upper harness straps loops onto the splitter plate. Make sure the straps **are on top** of the splitter plate and **are completely on**.

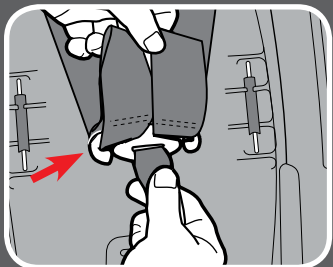
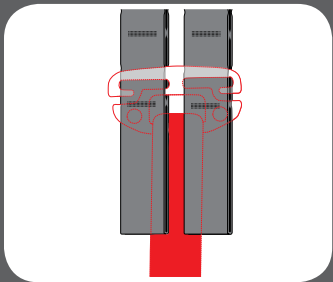
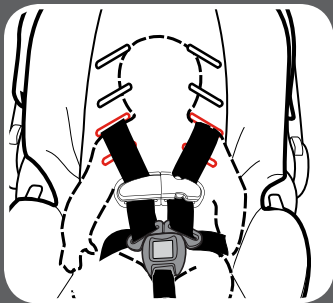
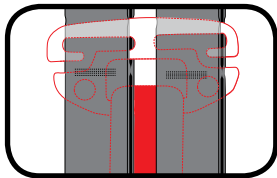

4 Securing
Child



4 Securing Child

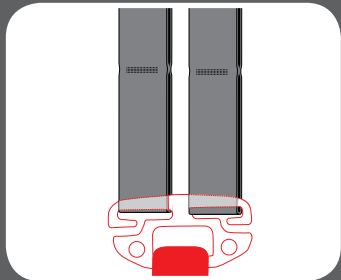
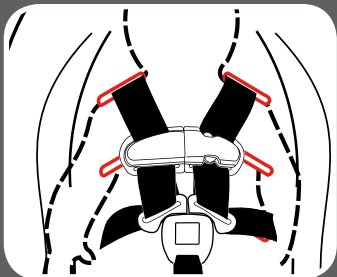

12. For Larger Baby

If the child's shoulders are even with or just below the upper 2 slots, use the lower loops on the harness straps.

Thread the lower harness straps loops onto the splitter plate. Make sure the straps **are completely on** the splitter plate.



4-B Adjust Buckle to Fit Child

1. Check the Buckle Position

The correct slot is the one that is closest to your child without being underneath them.

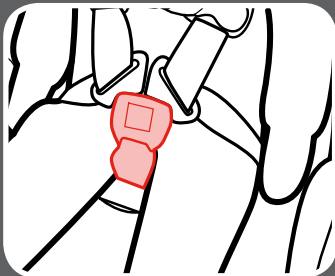

2. To Change Buckle Position

Remove child from the seat. From the bottom of car seat, insert the buckle's metal clip up through shell and pad.

From the front, pull buckle out of the pad and shell.

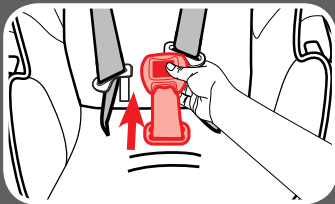
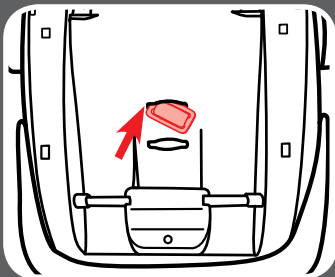



4 Securing Child

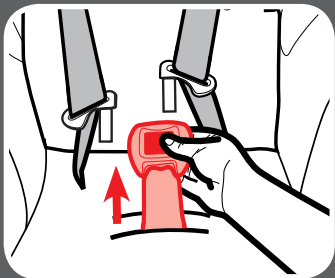
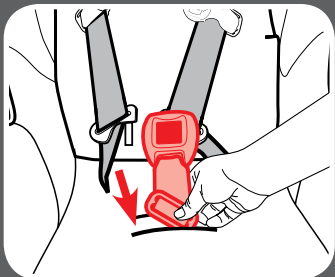

3. Insert Metal Clip Into New Location

Push metal clip down through the pad and shell. Make sure the buckle's red button is facing out.

4. Pull Up On Buckle To Check It Is Secured

Make sure buckle's metal clip is completely through pad and shell.



4-C Securing Child in Car Seat

1. Place Harness Straps Over Child's Shoulders

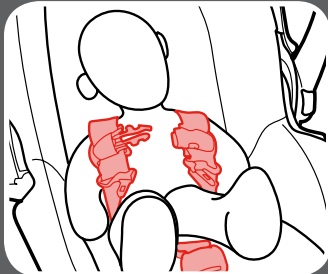

2. Buckle

You will hear a “click” when buckle tongues are securely attached. Pull up on each buckle tongue to make sure it is securely attached.

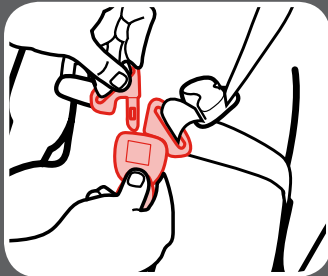

3. Buckle the Chest Clip

You will hear a “click” when the chest clip is securely buckled attached.

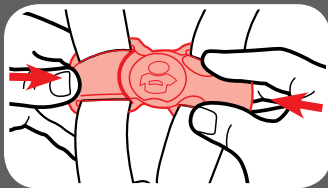

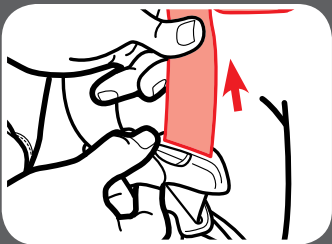

4. Pull All the Slack Out From Around the Waist

Pull up on the harness strap while pushing the chest clip down. Do this to both sides.

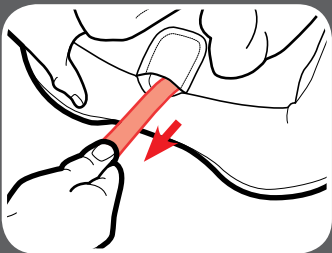

5. Tighten the Harness by Pulling the Harness Adjustment Strap

When you are not able to pinch any of the harness webbing at your child's shoulder, the harness is tight enough.

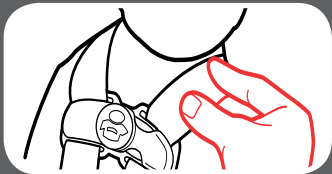

A snug harness should not allow any slack. It lies in a relatively straight line without sagging. It does not press on the child's flesh or push the child's body into an unnatural position.

**6. Raise the Chest
Clip to Child's
Armpit Level**

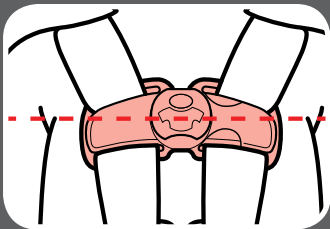

7. Check Tightness

Tighten more if
needed.

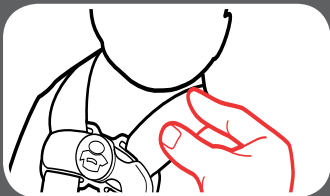



4-D Removing Child

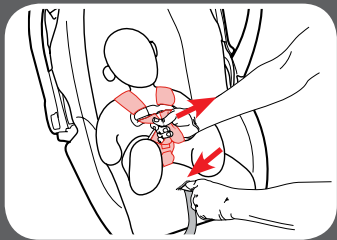

1. Loosen Harness Straps

Push down on the harness release lever while pulling out on the harness straps at the chest clip.

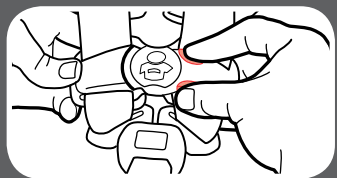

2. Release the Chest Clip

Squeeze the chest clip release buttons and pull apart.

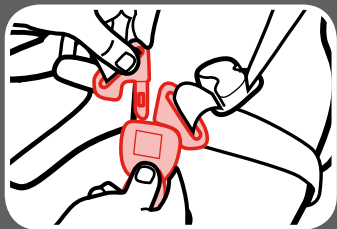

3. Unbuckle Your Child

Press in on the red button and remove the buckle tongues. Remove Child from the seat.

5-A Carrier Use

WARNING!

Read all instructions before use of the infant carrier. Keep instructions for future use. Do not use the infant carrier if it is damaged or broken.

NEVER leave child unattended. Always stay within arms reach of carrier.

SUFFOCATION HAZARD: Infant carrier can roll over on soft surfaces and suffocate child. **NEVER** place carrier on beds, sofas, or other soft surfaces.

STRANGULATION HAZARD: Children have **STRANGLER** in loose or partially buckled harness straps. Fully restrain the child even when carrier is used outside the vehicle.

FALL HAZARD: Child's movements can move carrier. **NEVER** place carrier on counter tops, tables or any other elevated surfaces.

KEEP STRINGS AND CORDS AWAY FROM CHILD. Strings and cords can cause strangulation. **DO NOT** place carrier near windows where cords from blinds or drapes can strangle a child. **DO NOT** hang strings on or over the carrier. **DO NOT** attach strings to toys.



5 Carrier
Use

! WARNING!

NEVER place carrier in the seating area or across the top of a shopping carts. This can result in serious injury or death to your child.



USE ONLY WITH STROLLERS THAT ARE PART OF THE GRACO CLICK CONNECT TRAVEL SYSTEM.

Refer to the stroller owner's manual for details on how to attach the infant carrier to your stroller. If you do not have an owner's manual, please visit our website at www.gracobaby.com to download the manual or call toll-free at 800-345-4109.



NEVER use a Graco infant carrier with any other manufacturer's strollers. This can result in serious injury or death.

6-A Additional LATCH Information

This car seat can be installed in your vehicle using either the vehicle seat belt OR the LATCH system. Both systems are equally safe to use. DO NOT USE BOTH AT THE SAME TIME.

The LATCH system allows you to securely attach your car seat in your car without using the vehicle seat belt and possibly to get a better fit. All 2003 and newer model year vehicles are required to have a LATCH system, although some manufacturers began including LATCH earlier. Some vehicle owner manuals use the term ISOFIX to identify the LATCH system.

Only use LATCH in seating positions recommended by your vehicle manufacturer. Review your vehicle owner's manual for more information.

6-B How to Remove LATCH

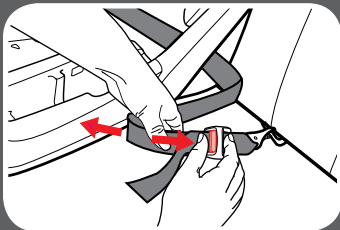

1. Push Gray Button In While Pulling on LATCH Strap to Loosen

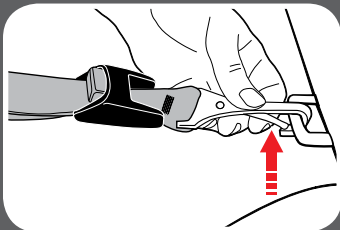

2. Press and Hold LATCH Release Hinge

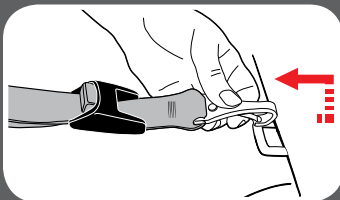

3. Push Hook In, Lift Hook Up and Pull Out Away From Anchor Point

6-C Unsafe Vehicle Seats

Never install this car seat in side-facing or rear-facing vehicle seats.



6-D Vehicle Seat Belts

Review your vehicle owner's manual for vehicle seat belt use

This car seat can be installed using a vehicle seat belt. To do this, you will need to change the seat belt to a locked mode for use with car seats. With some vehicle seat belts, this is done with the latch plate; with other vehicle seat belts, this is done with the retractor.

Vehicle Seat Belt Terms

Retractor

A device that winds up the unused vehicle seat belt. It is often hidden inside the panels on the walls of the vehicle or in the vehicle seat back.

Latch Plate

The male end of the seat belt with the silver tongue.

Seat Crease

The crease where the vehicle seat back and seat bottom meet.

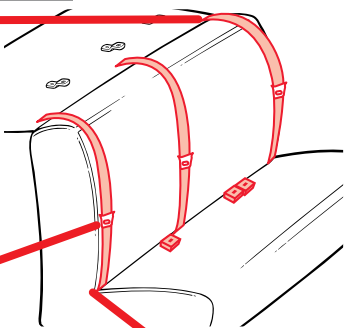

Identify Your Seat Belt Type

There are two different types of vehicle seat belts that can be used with this car seat:

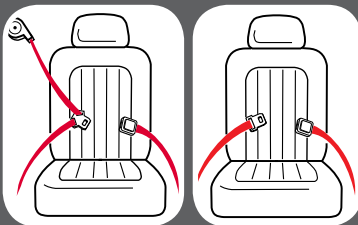

Lap/Shoulder Seat Belt
3 connection points.

Lap Only Seat Belt
2 connection points.

The following types of vehicle seat belts **CANNOT** be used safely with this car seat:



Lap Belt with Motorized
Shoulder Belt



Belts Forward of the
Seat Crease



Lap Belt or Shoulder
Belt Mounted on Door

Lap/Shoulder Seat Belt Installation

Always review your vehicle owner's manual for specific information about your vehicle seat belts.

There are three types of retractors: **ELR (Emergency Locking Retractor)**, **ALR (Automatic Locking Retractor)**, and **Switchable (ELR switch to ALR)**. To determine your type of retractor, follow these steps:

1. **Slowly** pull the belt out about halfway and stop.

2. Let the belt retract back several inches.

3. Try to **slowly** pull the belt out more. If the belt cannot be pulled any further, it is **ALR**, ready to install your car seat. If it can be pulled further, go to the next step.

4. **Slowly** pull the belt **all the way out**, and then allow it to retract several inches. You may hear some clicking sounds.

5. Try to pull the belt all the way out again. If it cannot be pulled out, it is **Switchable**, ready to install your car seat. If it can still be pulled out freely, it is **ELR**. Review the following pages to properly install your infant car seat.

Note: Most vehicles manufactured after 1996 will have Switchable retractors in the back seat. If you have any questions about your retractor type, consult your vehicle owner's manual or call Graco for assistance.

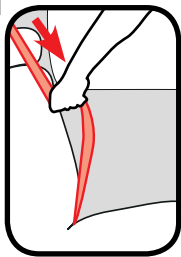

How to Lock Your Lap/Shoulder Vehicle Seat Belt

Sliding Latch Plate and Switchable Retractor

A latch plate that slides freely on the belt webbing and cannot, by itself, hold the belt snug around a car seat.

When installing the car seat, route the vehicle seat belt through the proper belt path and buckle it in.

Slowly pull the shoulder belt all the way out to switch it to locking mode. Then, as you pull the vehicle seat belt tight, feed all the slack back into the retractor.

Grab the sides of the base or seat at the belt path and slide side to side and front to back. The base or seat should not move more than 1" (2.5 cm).

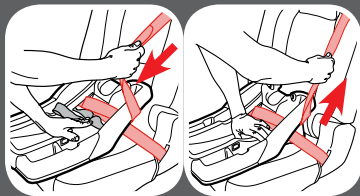
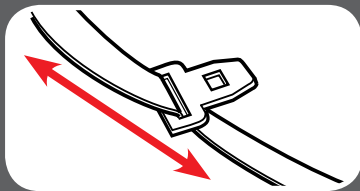

Note: With the vehicle seat belt in this locking mode, all the tension is upwards in the shoulder belt. This may start to tilt your car seat sideways. If this happens, use a locking clip instead of switching the retractor. See Sliding Latch Plate and ELR Retractor.

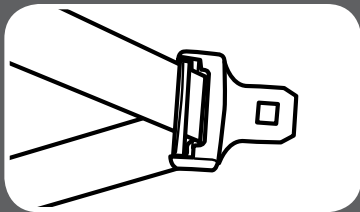

Locking Latch Plate and ELR Retractor

A latch plate that holds the lap belt snug after it has been adjusted; contains a metal bar on the underside of the hardware that “locks” the belt in position.

When installing the car seat, route the vehicle seat belt through the proper belt path and buckle it in. Then, pull upwards on the shoulder belt so that the lap belt gets tight around the base or car seat.

Grab the sides of the base or seat at the belt path and slide side to side and front to back. The base or seat should not move more than 1” (2.5 cm).

Sliding Latch Plate and ALR Retractor

A latch plate that slides freely on the belt webbing and cannot, by itself, hold the belt snug around a car seat.

Slowly pull the shoulder belt all the way out. Route the vehicle seat belt through the proper belt path and buckle it in. Then, as you pull the vehicle seat belt tight, feed all the slack back into the retractor.

Grab the sides of the base or seat at the belt path and slide side-to-side and front-to-back. The base or seat should not move more than 1" (2.5 cm).

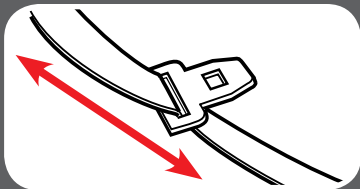

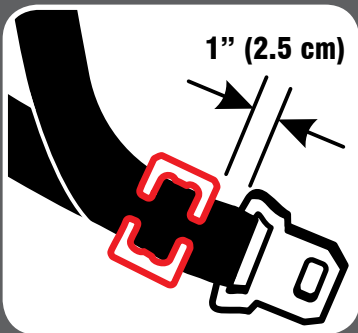
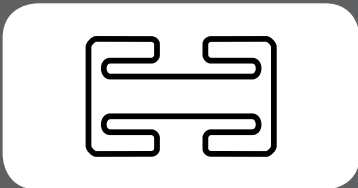
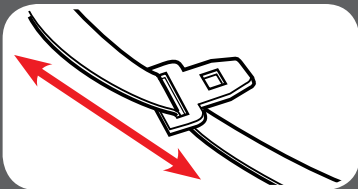

Sliding Latch Plate and ELR Retractor

A latch plate that slides freely on the belt webbing and cannot, by itself, hold the belt snug around a car seat.

With this retractor, you will need to use the locking clip to lock the vehicle seat belt.

Route the vehicle seat belt through the proper belt path and buckle it in. Pull the vehicle seat belt tight. While pushing down on seat, pinch the two straps together behind the buckle tongue. Unbuckle the belt without allowing it to slip.

Attach locking clip to lap and shoulder belts as shown.

Buckle belt. Check that lap belt does not move by pulling hard. If belt loosens or lengthens, repeat procedure.

Lap Belt Installation

Always review your vehicle owner's manual for specific information about your vehicle seat belts.

Locking Latch Plate and No Retractor

When installing the car seat, route the lap seat belt through the proper path and buckle it in.

Then, pull upwards on the tail of the belt so that the lap belt gets tight around the car seat.

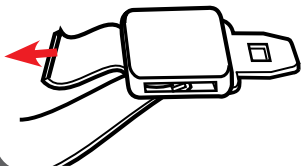

Grab the sides of the seat at the belt path and slide side to side and front to back. The base or seat should not move more than 1" (2.5 cm).

Sewn On Latch Plate and ALR Retractor

Slowly pull the lap belt all the way out. Route the vehicle seat lap belt through the proper belt path and buckle it in. Then, pull the lap belt tight while feeding all the slack back into the retractor.

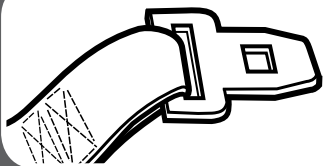

Grab the sides of the seat at the belt path and slide side to side and front to back. The base or seat should not move more than 1" (2.5 cm).

7-A Accessories *(on select models)*

! WARNING!

**To prevent ejection in sudden stop or crash:
Use body support with bottom 2 sets of harness
slots only.**

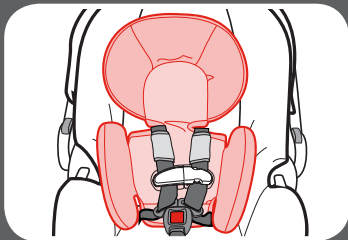

Body Pillow

To remove, pull the body pillow out from behind the harness straps.

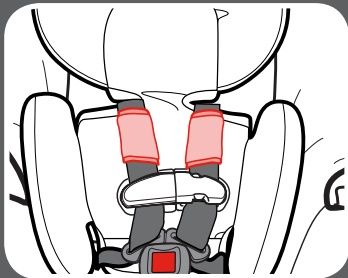

Harness Covers

Make sure that harness covers do not interfere with the placement of the chest clip at armpit level. To remove, review section 4-A to unthread the harness system.

8-A Cleaning Seat Pad

1. Loosen Harness Straps

Push down on the harness release lever while pulling out on the harness straps at the chest clip.

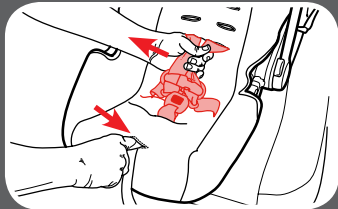

2. Remove Harness Straps from Splitter Plate

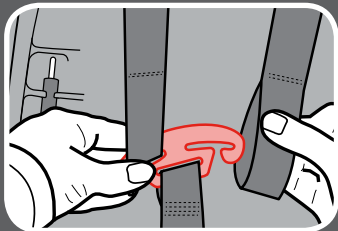

3. Pull Harness Straps Out From the Front of Car Seat



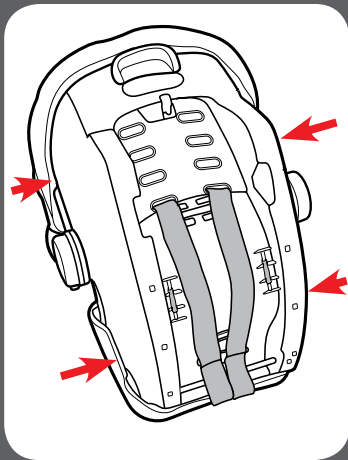

**4. Pull Out the 4
Plastic Flaps from
Sides of Seat**

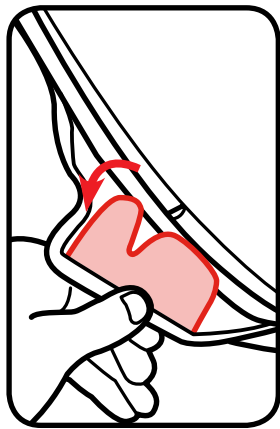
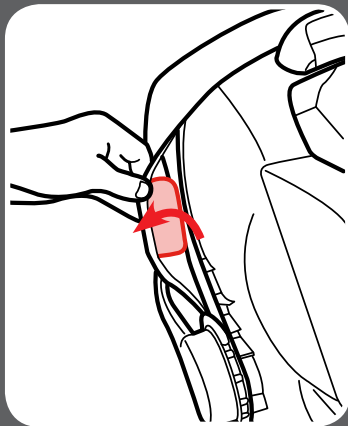

5. Pull Pad Off Shell

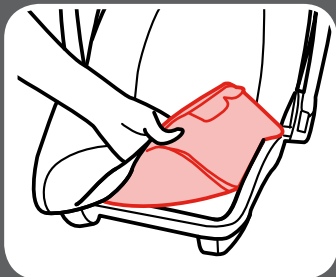

6. Remove Canopy from Canopy Hoop

Slide the canopy to one side of the canopy hoop. From the center, pull the canopy hoop apart and remove canopy.

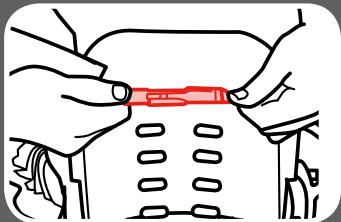

Machine wash pad and canopy in cold water on delicate cycle and drip-dry. **DO NOT USE BLEACH.**

Reverse the steps to reattach the pad to the shell. Make sure harness straps are not twisted.

8-B Cleaning Buckle

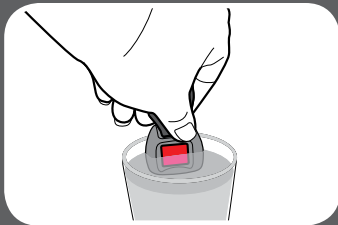
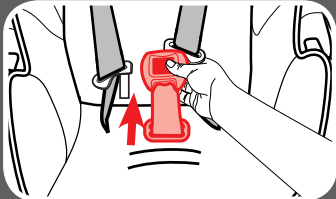
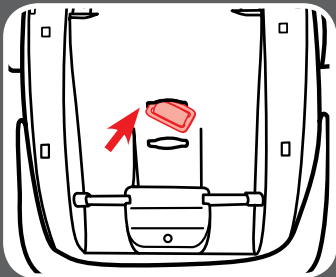

Remove Buckle to Clean

From the bottom of car seat, insert the buckle's metal clip up through shell and pad. From the front, pull buckle out of the pad and shell.

To clean, place in a cup of warm water and gently agitate the buckle. Press the red button several times while in the water.

DO NOT SUBMERGE THE BUCKLE STRAP. DO NOT USE SOAPS, HOUSEHOLD DETERGENTS or LUBRICANTS.

Shake out excess water and allow to air dry. Repeat steps as needed until it fastens with a click. Re-insert the buckle into the same slot it was removed. Pull up on crotch buckle to make sure it is secured.

WARNING! Inspect and clean buckle from time to time to remove any objects or debris that could prevent latching.

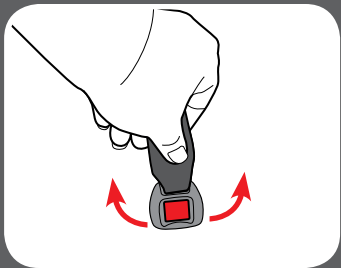

NOTES

NOTES

Replacement Parts

To purchase parts or accessories in the United States,
please contact us at the following:

www.gracobaby.com

or

1-800-345-4109

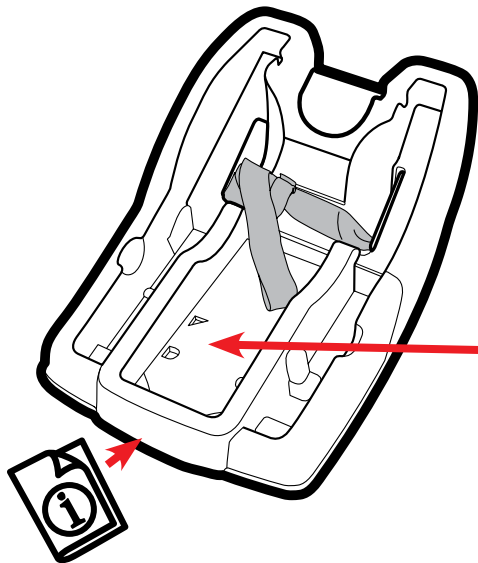

Store instruction manual in the slots on the bottom of the base where the instruction book icon is shown.



www.gracobaby.com

BREAZE™



- Owners' Manual
- Manual del propietario

WARNING

Failure to follow these warnings and the assembly instructions could result in serious injury or death.

- **PLEASE SAVE OWNER'S MANUAL FOR FUTURE USE.**
- **ADULT ASSEMBLY REQUIRED.**
- **NEVER LEAVE** child unattended. Always keep child in view while in stroller.
- **AVOID SERIOUS INJURY** from falling or sliding out. Always use seat belt. After fastening buckles, adjust belts to get a snug fit around your child.
- **AVOID FINGER ENTRAPMENT:** Use care when folding and unfolding the stroller. Be certain the stroller is fully erected and latched before allowing your child near the stroller.
- **CHILD MAY SLIP INTO LEG OPENINGS AND STRANGLE.** Do not use in reclined carriage position with an older child that can lift up on hands and knees or crawl out. NEVER use in full recline position unless footrest is in the reclined carriage position.
- **NEVER USE STROLLER ON STAIRS** or escalators. You may suddenly lose control of the stroller or your child may fall out. Also, use extra care when going up or down a step or curb.
- **STROLLER TO BE USED** only at walking speed. Product not intended for use while jogging, skating, etc.
- **USE OF THE STROLLER** with a child weighing more than 50 lbs (22.7 kg) or taller than 45 in. (114.3 cm) will cause excessive wear and stress on the stroller. Use the stroller with only one child at a time.
- **TO PREVENT TIPPING,** do not place more than 1 lb (.45 kg) in the cupholder.
- **TO AVOID BURNS,** never put hot liquids in the cupholder.
- **TO PREVENT A HAZARDOUS, UNSTABLE CONDITION,** never place purses, shopping bags, parcels or accessory items (other than approved Graco stroller bags) on the handle. Never place anything on the canopy.
- **TO PREVENT A HAZARDOUS, UNSTABLE CONDITION,** do not place more than 10 lbs (4.5 kg) in the storage basket, or more than 2 lbs (0.9 kg) in the mesh side pockets (on certain models).
- **DO NOT** use storage basket as a child carrier.
- **DO NOT ALLOW** your child to stand on the basket. It may collapse and cause injury.
- **NEVER PLACE** child in the stroller with head toward front of stroller.

⚠ WARNING

- **NEVER ALLOW YOUR STROLLER** to be used as a toy.
- **DISCONTINUE USING YOUR STROLLER** should it become damaged or broken.
- **AVOID STRANGULATION.** DO NOT place items with a string around your child's neck, suspend strings from this product, or attach strings to toys.

USING GRACO® INFANT CAR SEAT WITH STROLLER:

- **TO AVOID INJURY TO YOUR CHILD:**

This stroller is only compatible with Graco® SnugRide® infant car seats with Click Connect™. Only use with Graco® infant car seats that have the Click Connect™ logo. Improper use of this stroller with other manufacturers' carseats may result in serious injury or death.



- **READ THE MANUAL** provided with your Graco car seat before using it with your stroller.
- **ALWAYS SECURE** your child with the car seat harness when using the car seat in the stroller. If your child is already in the car seat, check that the child is secured with the harness.

ADVERTENCIA

No observar estas advertencias y las instrucciones de armado podría resultar en lesiones serias o la muerte.

- **POR FAVOR, GUARDE EL MANUAL DEL PROPIETARIO PARA USO FUTURO.**
- **REQUIERE QUE LO ARME UN ADULTO.**
- **NUNCA DEJE** al niño sin supervisión. Mantenga al niño siempre a la vista cuando esté en el cochecito.
- **EVITE SERIAS LESIONES** de caídas o resbalos. Use siempre el cinturón de seguridad. Después de ajustar las hebillas, ajuste las correas para obtener un calce apretado alrededor de su niño.
- **EVITE AGARRARLE LOS DEDOS:** Use cuidado cuando pliega y despliega el cochecito. Asegúrese de que el cochecito esté completamente armado y trabado antes de permitir que el niño se acerque al mismo.
- **EL NIÑO PODRÍA CAERSE POR LAS ABERTURAS DE LAS PIERNAS Y ESTRANGULARSE.** No use en la posición totalmente reclinada con un niño mayor que puede levantarse en sus manos y rodillas o salir gateando. **NUNCA** lo use en la posición totalmente reclinada a menos que el apoyapié esté en la posición del cochecito reclinado.
- **NUNCA USE EL COCHECITO EN ESCALERAS** o escaleras mecánicas. Podría perder repentinamente el control del cochecito o el niño podría caerse. Además, use mucho cuidado cuando sube o baja un escalón o borde.
- **EL COCHECITO DEBE USARSE** solamente a la velocidad del caminar. El producto no debe usarse para correr, patinar, etc.
- **USAR EL COCHECITO** con un niño que pesa más de 50 libras (22.7 kg) o más alto de 45 pulgadas (114.3 cm) causará un desgaste y tensión excesiva en el cochecito. Use el cochecito solamente con un niño por vez.
- **PARA PREVENIR QUE SE TUMBE,** no ponga más de 1 libra (0.45 kg) en el apoyavasos.
- **PARA EVITAR QUEMADURAS,** nunca ponga líquidos calientes en el apoyavasos.
- **PARA PREVENIR UNA SITUACIÓN PELIGROSA E INESTABLE,** nunca ponga carteras, bolsas, paquetes o accesorios (que no sean las bolsas para cochecito aprobadas por Graco) en la manija. No ponga nunca nada sobre la capota.

⚠ ADVERTENCIA

- **PARA PREVENIR UNA SITUACIÓN PELIGROSA E INESTABLE**, no ponga más de 10 libras (4.5 kg) en la canasta de almacenamiento y no ponga más de 2 libras (0.9 kg) en los bolsillos laterales tejidos (en ciertos modelos).
- **NO** use la canasta de almacenamiento como transportador para niños.
- **NO DEJE** que el niño se pare sobre la canasta. Podría desarmarse y causar lesiones.
- **NUNCA PONGA** a un niño en el cochecito con la cabeza hacia el frente del cochecito.
- **NUNCA DEJE QUE SU PRODUCTO SE USE** como un juguete.
- **DEJE DE USAR EL COCHECITO** en caso de que esté dañado o roto.
- **EVITE LA ESTRANGULACIÓN.** NO ponga artículos con un cordón alrededor del cuello del niño, suspenda cordones de este producto ni ponga cordones a los juguetes.

USO DEL TRANSPORTADOR PARA BEBÉ GRACO® CON EL COCHECITO:

- **PARA EVITAR LESIONES A SU NIÑO:** Este cochecito solamente es compatible con los asientos de automóvil para bebé Graco® SnugRide® con Click Connect™. Úselo solamente con los asientos de automóvil para bebé de Graco® que tienen el logotipo Click Connect™. El uso inadecuado de este cochecito con asientos para automóvil de otros fabricantes podría resultar en lesiones serias o la muerte.
- **LEA EL MANUAL** incluido con su transportador Graco antes de usarlo con su cochecito.
- **ASEGURE SIEMPRE** a su niño con el arnés del transportador cuando usa el transportador en el cochecito. Si su niño ya está en el transportador, verifique que esté asegurado con el arnés.



Parts list • Lista de piezas

This model may not include some features shown below. **Check** that you have all the parts for this model **BEFORE** assembling your product. If any parts are missing, call Customer Service.

Este modelo podría no incluir algunas de las características que se indican a continuación. **Verifique** que tiene todas las piezas de este modelo **ANTES** de armar su producto. Si falta alguna pieza, llame a Servicio al Cliente.

ALL MODELS • TODOS LOS MODELOS

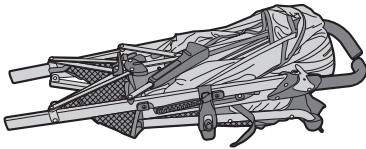

2X

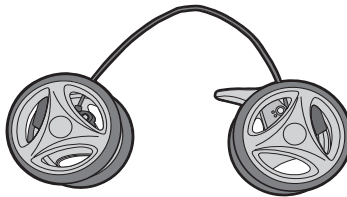

ON CERTAIN MODELS • EN CIERTOS MODELOS

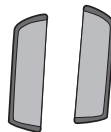

To Open Stroller • Cómo abrir el cochecito

Before assembly be sure to place stroller on top of a piece of cardboard or other protective cover to prevent damage to floor surface.

Antes de armarlo, tenga la seguridad de poner el cochecito arriba de un pedazo de cartón u otro tipo de protección para prevenir el daño a la superficie del piso.

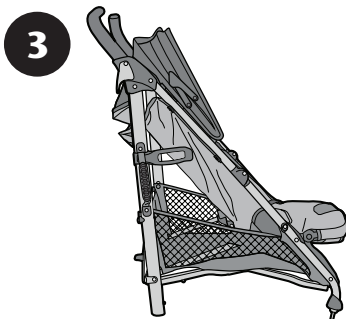
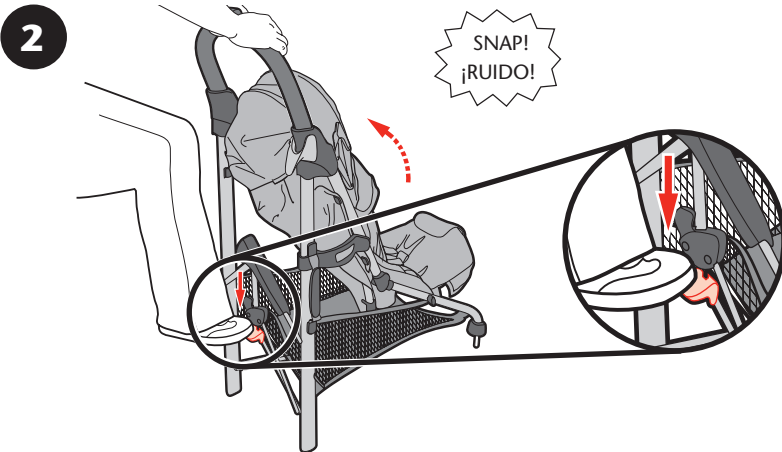
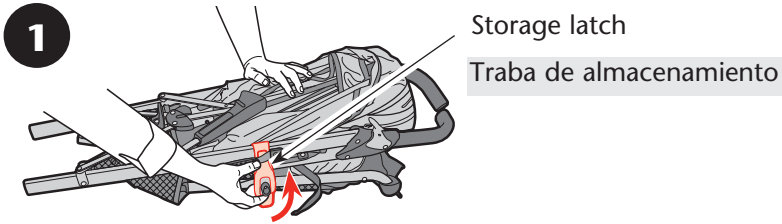

CHECK that stroller is completely latched open before continuing.

VERIFIQUE que el cochecito esté completamente abierto antes de continuar.

Front Wheels • Ruedas delanteras



2X

1

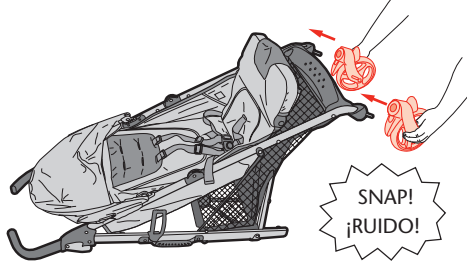

CHECK that wheels are securely attached by pulling on wheel assemblies.

VERIFIQUE que las ruedas estén instaladas correctamente tirando de los ensamblajes de la rueda.

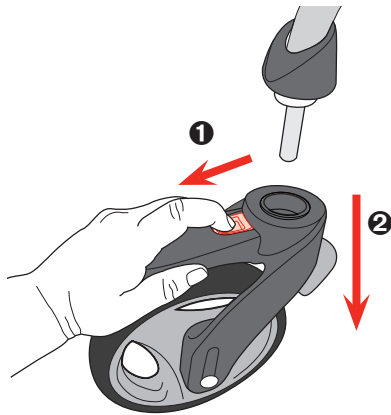

To remove.

Para sacarla.

Rear Wheels • Ruedas traseras

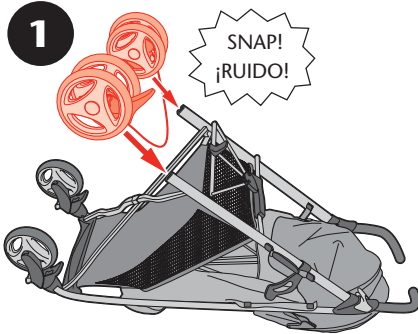

The rear wheels can only go on one way. Brake lever points toward rear of stroller.

Las ruedas traseras solamente se pueden montar de una manera. La palanca del freno apunta hacia la parte trasera del cochecito.

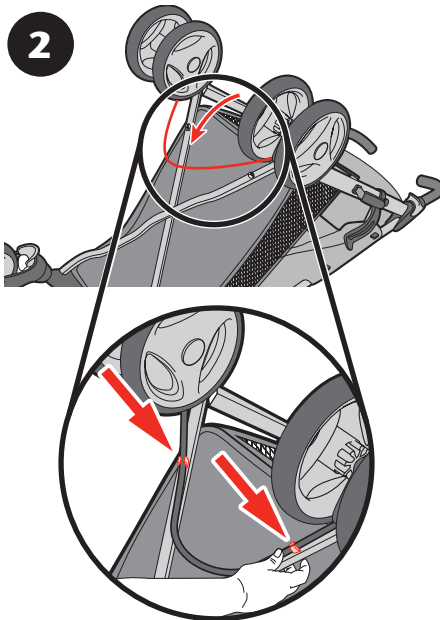

Pull brake line under stroller and attach to plastic clips as shown.

Tire la línea del freno de abajo del cochecito y sujétela a las presillas de plástico como se indica.

Canopy • Capota

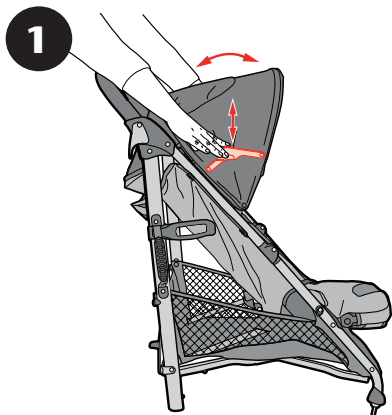

To open. To close.

Para abrir la capota.
Para cerrarla.

Cupholder • Apoyavaso

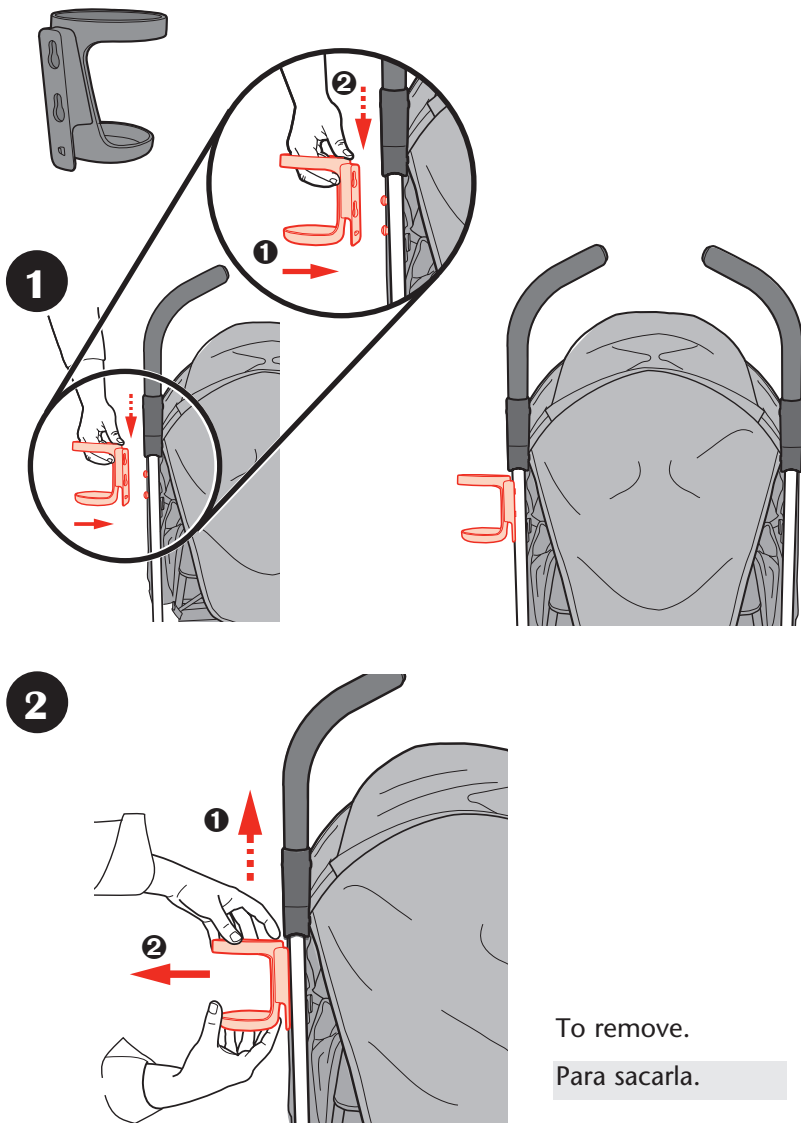

To Use Brake • Cómo usar el freno

⚠ WARNING Always apply brake. Check that brake is on by trying to push stroller.

⚠ ADVERTENCIA Use siempre el freno. Verifique que el freno esté activado tratando de empujar el cochecito.

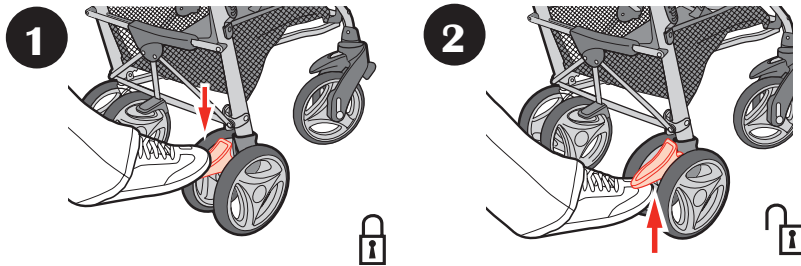

Swivel Wheels • Ruedas giratorias

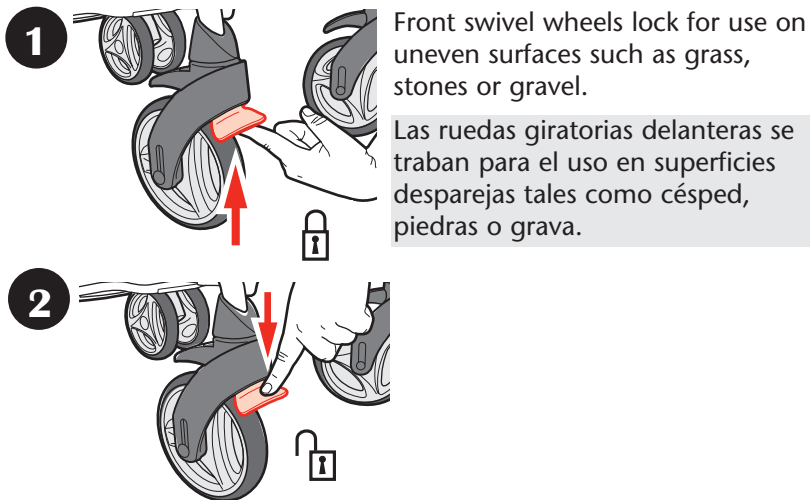

Front swivel wheels lock for use on uneven surfaces such as grass, stones or gravel.

Las ruedas giratorias delanteras se traban para el uso en superficies desparejas tales como césped, piedras o grava.

To Recline Seat • Para reclinar el asiento

⚠ WARNING

Fabric caught in the latches may prevent them from locking. When returning seat to upright position, do not allow fabric to be pinched in the latch.

When making adjustments to the stroller seat, make sure child's head, arms, and legs are clear of moving seat parts and stroller frame. Do not use in reclined carriage position with an older child that can lift up on hands and knees or crawl out.

⚠ ADVERTENCIA

La tela que se enganche en las trabas podría impedir que se traben. Cuando vuelve a poner el asiento en la posición vertical, no permita que la tela quede enganchada en la traba.

Cuando realiza ajustes al asiento del cochecito, asegúrese que la cabeza, brazos y piernas del niño están lejos de las piezas del asiento que se mueven y del armazón del cochecito.

No use en la posición totalmente inclinada con un niño mayor que puede levantarse en sus manos y rodillas o salir gateando.

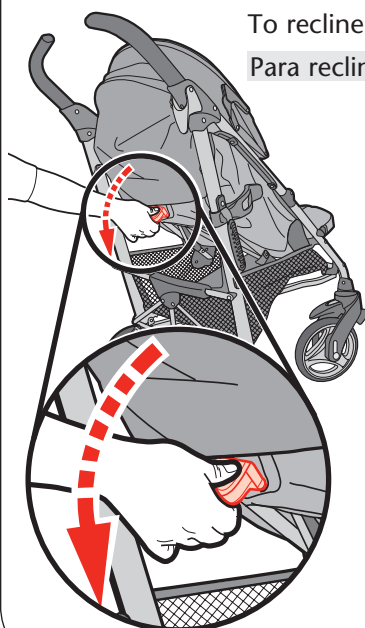

5 Positions

5 Posiciones

To Adjust Leg Rest

- Para ajustar el descanso de la pierna

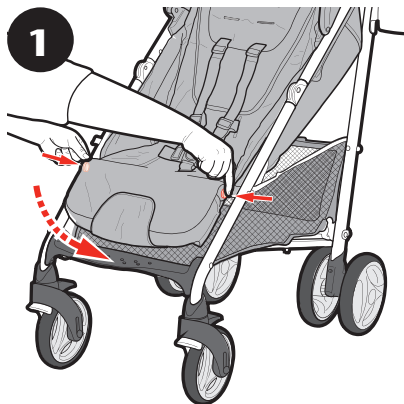

To lower leg rest, press buttons on side of seat as shown.

Para bajar el descanso de la pierna, oprima los botones del costado del asiento como se indica.



To raise leg rest, lift up seat as shown.

Para levantar el descanso de la pierna, levante el asiento como se indica.

Reclined Carriage Position

- Posición reclinada del cochecito

⚠ WARNING

- Child may slip into leg openings and strangle. NEVER use in full recline position unless footrest is in the reclined carriage position.
- Do not use in reclined carriage position with an older child that can lift up on hands and knees or crawl out.
- Never use any head support in the full recline position.
- To avoid entrapment or strangulation, always attach side flaps when footrest is fully raised.

⚠ ADVERTENCIA

- El niño podría caerse por las aberturas de las piernas y estrangularse. NUNCA lo use en la posición totalmente reclinada a menos que el apoyapié esté en la posición del cochecito reclinado.
- No use en la posición totalmente reclinada con un niño mayor que puede levantarse en sus manos y rodillas o salir gateando.
- Nunca use un soporte de la cabeza en la posición totalmente reclinada.
- Para evitar el atrapamiento o la estrangulación, sujete siempre las aletas laterales cuando el apoyapie está completamente levantado.

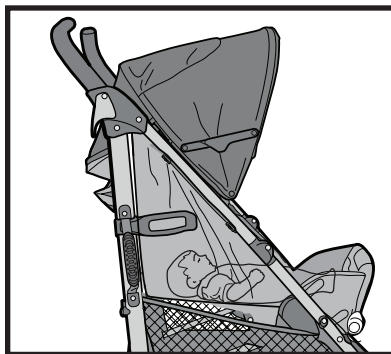

1



Recline seat to lowest position.

Recline el asiento hasta la posición más baja.

2

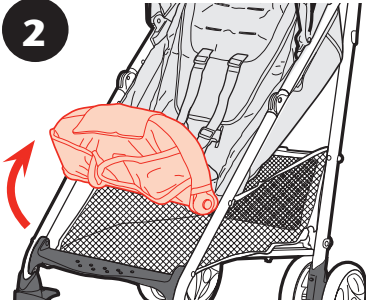

Raise the legrest to fully upright position as shown.

Levante el soporte de las piernas hasta la posición completamente vertical como se indica.

3

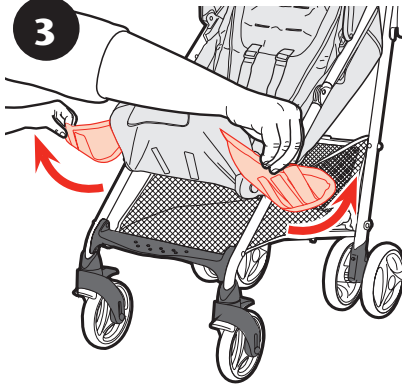

Remove flaps from bottom of legrest.

Para las aletas de abajo del descanso para las piernas.

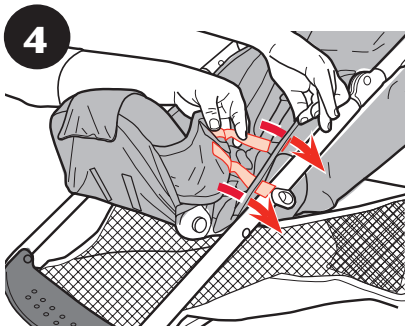

4
Unfasten straps and thread straps through button holes on each side of seat cover.

Desabroche las correas y páselas a través de los agujeros en cada costado de la funda del asiento.

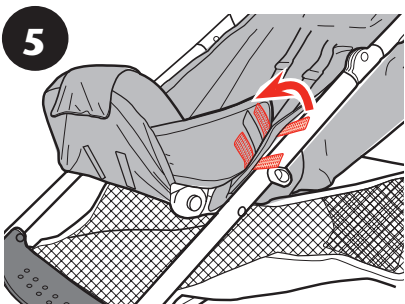

5
Fasten hook and loop tape on both sides of the stroller to secure.

Sujete la cinta de gancho y nudo en ambos costados del cochecito para asegurarlo.

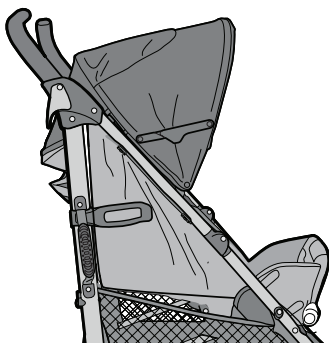
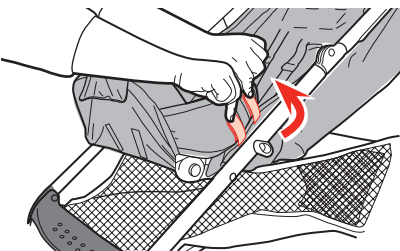

To Secure Child • Cómo asegurar al niño

5 Point Harness • Arnés de 5 puntos

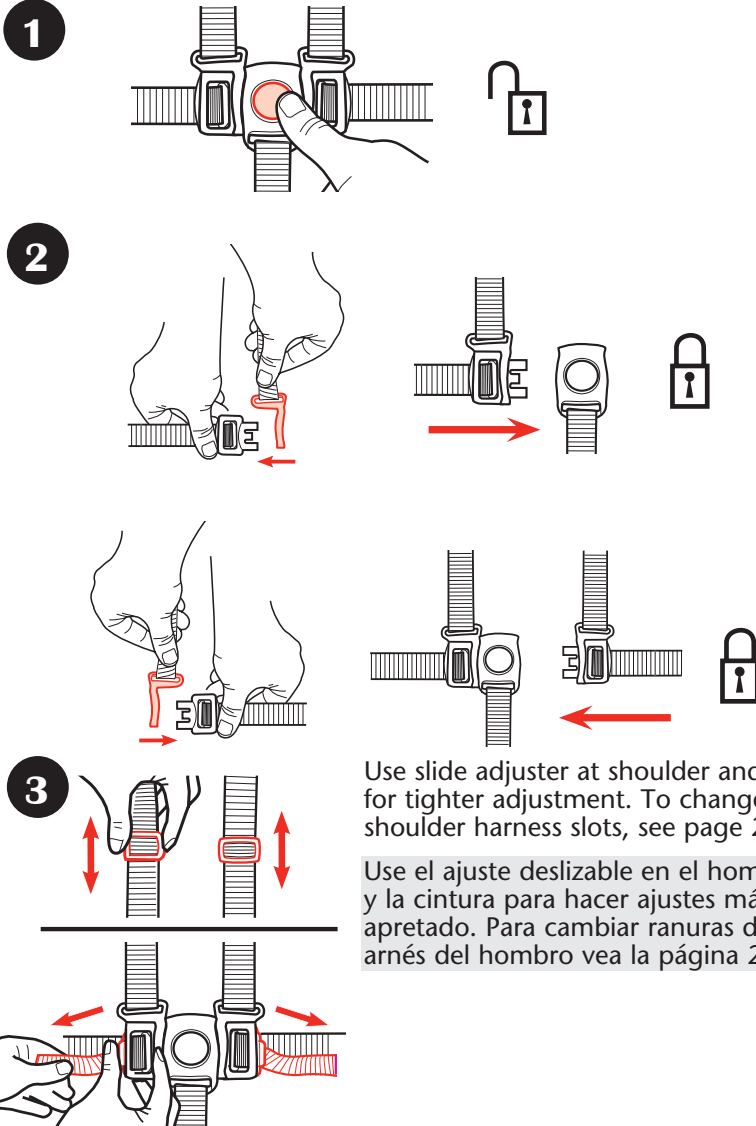

3 Point Buckle • Hebilla de 3 puntos

1

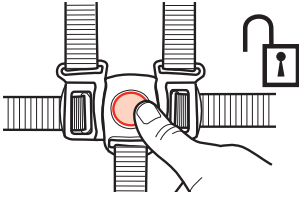

To convert to 3-pt harness.

Para convertirlo en un arnés de 3 puntos.

2

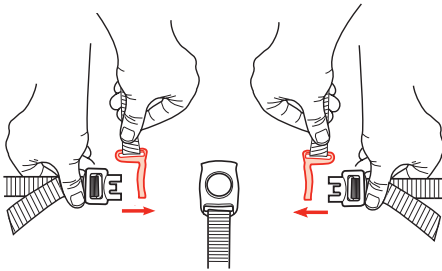

3

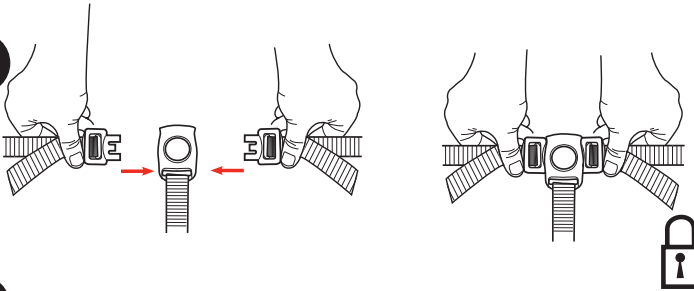

4

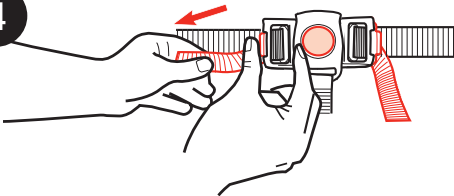

Use slide adjuster at waist for tighter adjustment.

5

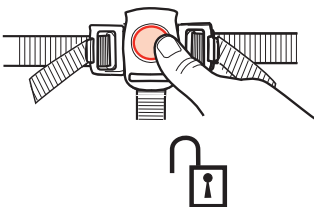

Use el ajuste deslizable a la cintura para hacer ajustes más apretado.

To Change Shoulder Harness Slots • Cómo cambiar las ranuras del arnés del hombro

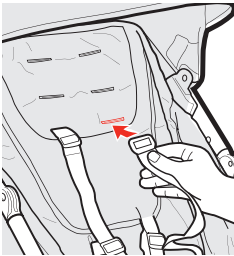
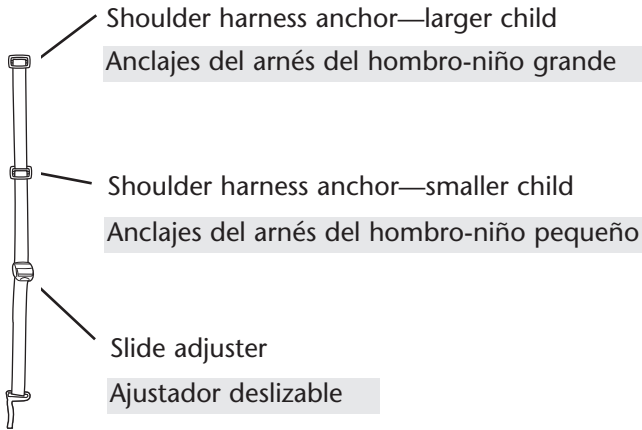

Use either shoulder harness anchor in the slots that are closest to child's shoulder height.

Use slide adjuster for further adjustment.

Use uno de los anclajes del arnés del hombro en las ranuras que estén más cerca a la altura del hombro del niño.

Use el ajustador deslizable para lograr ajustes adicionales.

To Fold • Cómo plegarlo

1

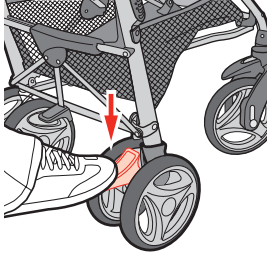

Before folding stroller, fold canopy and apply brake.

Antes de plegar el cochecito, pliegue la capota y aplique el freno.

2

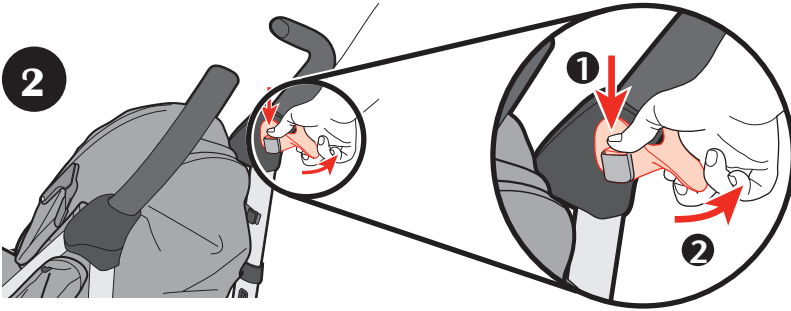

3

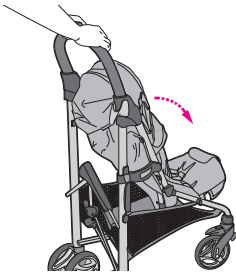

4

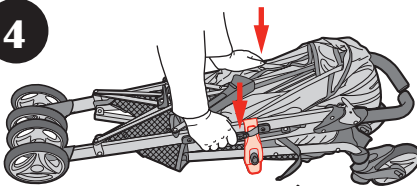

SNAP!
¡RUIDO!

Storage latch will engage automatically.

La traba de almacenamiento se activará automáticamente.

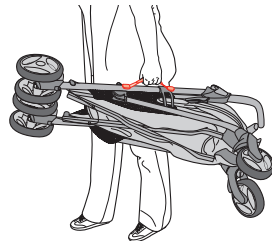

To Attach Graco® Infant Car Seat • Cómo instalar el asiento de automóvil para bebé Graco®

For models that do not come with an infant car seat one may be purchased separately.

⚠️ WARNING TO AVOID INJURY TO

YOUR CHILD: This stroller is only compatible with Graco® SnugRide® infant car seats with Click Connect™. Only use with Graco® infant car seats that have the Click Connect™ logo. Improper use of this stroller with other manufacturers' carseats may result in serious injury or death. Read the manual provided with your Graco car seat before using it with your stroller.



- Always secure your child with the car seat harness when using the car seat in the stroller. If your child is already in the car seat, **check that the child is secured with the harness.**

Para los modelos que no vienen con un asiento de automóvil para bebé, se puede comprar uno por separado.

⚠️ ADVERTENCIA PARA

EVITAR LESIONES A SU NIÑO: Este cochecito solamente es compatible con los asientos de automóvil para bebé Graco® SnugRide® con Click Connect™. Úselo solamente con los asientos de automóvil para bebé de Graco® que tienen el logotipo Click Connect™. El uso inadecuado de este cochecito con asientos para automóvil de otros fabricantes podría resultar en lesiones serias o la muerte. Lea el manual provisto con su asiento de automóvil Graco antes de usarlo con su cochecito.



- Sujete siempre a su niño con el arnés del asiento de automóvil cuando usa el asiento de automóvil en el cochecito. Si su niño ya está en el asiento de automóvil, **verifique que esté sujetado con el arnés.**

1

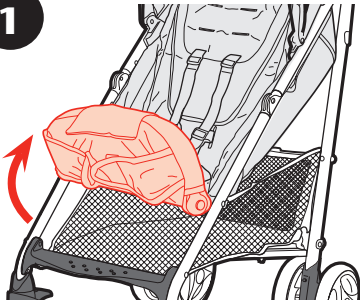

Raise the legrest to fully upright position as shown.

Levante el soporte de las piernas hasta la posición completamente vertical como se indica.

2

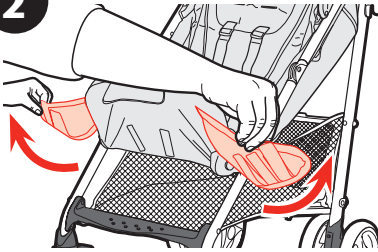

Remove flaps from bottom of legrest.

Para las aletas de abajo del descanso para las piernas.

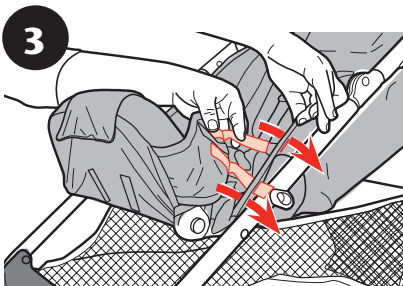

3 Thread straps through button holes on each side of seat cover.

Pase las correas a través de los agujeros del botón en cada costado de la funda del asiento.

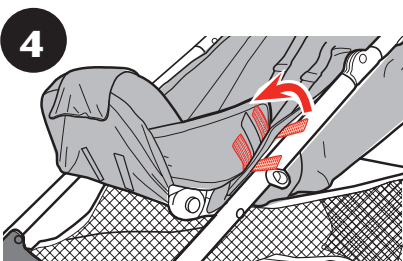

4 Fasten hook and loop tape on each side to secure.

Sujete la cinta de nudo y gancho en cada costado para asegurarlo.

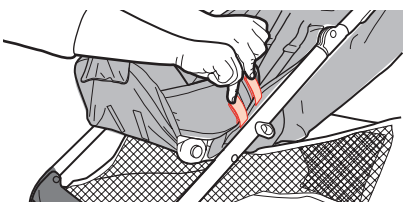

5 Open carseat attachment flap as shown.

Abra la aleta del asiento de automóvil como se indica.

6

Mounts
Soportes

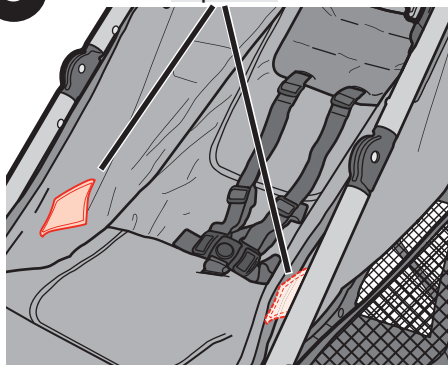

Recline the stroller seat back to its lowest position. Locate the 2 Click Connect™ mounts.

Recline el respaldo del asiento del cochecito hasta la posición más baja. Ubique los 2 montantes Click Connect™.

7

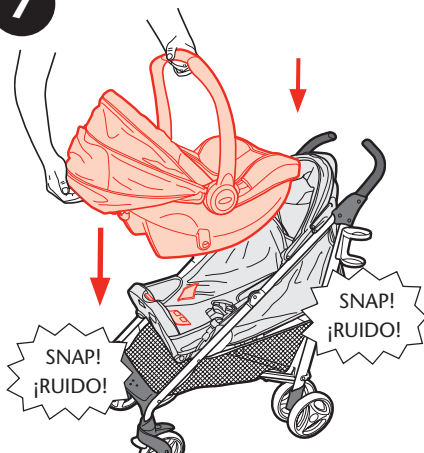

Insert carseat into stroller and push down on car seat until the latches snap into the Click Connect™ mounts.

Ponga el asiento para automóvil en el cochecito y empuje el asiento para automóvil hacia abajo hasta que se trabe en los soportes Click Connect™.

8

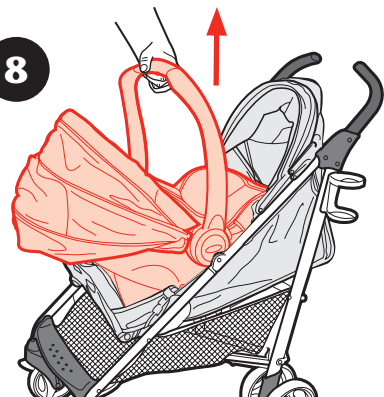

CHECK that infant car seat is securely attached by pulling up on it.

VERIFIQUE QUE el asiento de automóvil para bebé esté debidamente instalado conectado con firmeza tirando hacia arriba de la misma.

9

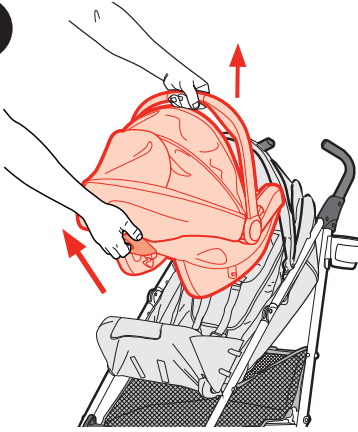

To remove car seat:
squeeze release handle at
back of car seat, and lift car
seat out of the stroller.

**Para sacar el asiento de
automóvil:** apriete la
manija de liberación de atrás
del asiento de automóvil y
levante el asiento de
automóvil fuera del
cochecito.

Harness Covers (on certain models)

- **Fundas del arnés (en ciertos modelos)**

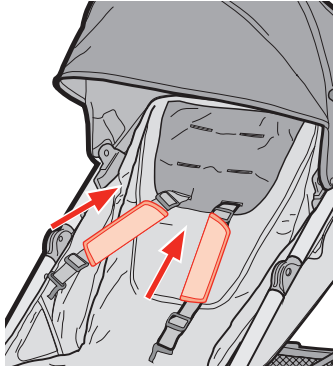

Only use these harness covers on this stroller. Never use these harness covers on any other product.

Slide harness covers onto shoulder straps.

Use las fundas del arnés solamente en este cochecito. Nunca use las fundas del arnés en ningún otro producto.

Deslice las fundas del arnés sobre las correas de los hombros.

Care and Maintenance

- **REMOVABLE SEAT PAD** (if so equipped) Refer to your care tag on your seat pad for washing instructions. **NO BLEACH.**
- **TO CLEAN STROLLER FRAME,** use only household soap and warm water. **NO BLEACH** or detergent.
- **FROM TIME TO TIME CHECK YOUR STROLLER** for loose screws, worn parts, torn material or stitching. Replace or repair the parts as needed. Use only Graco replacement parts.
- **EXCESSIVE EXPOSURE TO SUN OR HEAT** could cause fading or warping of parts.
- **IF STROLLER BECOMES WET,** open canopy and allow to dry thoroughly before storing.
- **IF WHEEL SQUEAKS,** use a light oil (e.g., WD-40, 3-in-1, or sewing machine oil). It is important to get the oil into the axle and wheel assembly as illustrated.
- **WHEN USING YOUR STROLLER AT THE BEACH** completely clean your stroller afterward to remove sand and salt from mechanisms and wheel assemblies.

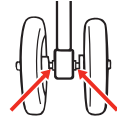

Atención y mantenimiento

- **LA ALMOHADILLA REMOVIBLE PARA EL ASIENTO** (si así está equipada) Consulte la etiqueta de cuidado de la almohadilla del asiento para obtener las instrucciones para el lavado. **NO USE BLANQUEADOR.**
- **PARA LIMPIAR EL ARMAZÓN DEL COCHECITO**, use solamente jabón de uso doméstico y agua tibia. **NO USE BLANQUEADOR** ni detergente.
- **DE VEZ EN CUANDO, INSPECCIONE SU COCHECITO** para determinar si hay tornillos flojos, piezas gastadas, material o puntos rotos. Cambie o repare las piezas según sea necesario. Use solamente piezas de repuesto Graco.
- **EL CONTACTO EXCESIVO CON EL SOL O EL CALOR** podría causar descoloramiento o torcedura de las piezas.
- **SI EL COCHECITO SE MOJA**, abra la capota y déjelo secar antes de guardarlo.
- **SI LAS RUEDAS HACEN RUIDO**, use un aceite liviano (por ejemplo, WD-40, 3 en 1, o aceite para máquina de coser). Es importante que el aceite penetre en el eje y ensamblaje de la rueda como se indica.
- **CUANDO USA SU PRODUCTO EN LA PLAYA** limpie completamente su cochecito después de usarlo para sacar la arena y sal de los mecanismos y ensamblajes de las ruedas.

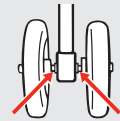

Notes • Notas

Notes • Notas

Replacement Parts • Warranty Information (USA)
Piezas de repuesto • Servicio de la garantía (EE.UU.)

To purchase parts or accessories or for warranty information in the United States, please contact us at the following:

Para comprar repuestos o accesorios o para el servicio de la garantía en los Estados Unidos, por favor comuníquese con nosotros en:

www.gracobaby.com

or/o

1-800-345-4109

Product Registration (USA)
Registro del producto (EE.UU.)

To register your Graco product from within the U.S.A. visit us online at www.gracobaby.com/productregistration or return registration card provided with your product. We currently do not accept product registrations from those living outside the United States of America.

Para registrar su producto Graco desde dentro de los EE.UU., visítenos en línea en www.gracobaby.com/productregistration o envíe la tarjeta de registro provista con su producto. Actualmente no aceptamos registros de los productos de quienes viven fuera de los Estados Unidos de América.