

Shown with
Optional Equipment

CAT® ENGINE SPECIFICATIONS

V-12, 4-Stroke-Cycle

Bore	137 mm (5.4 in.)
Stroke	152 mm (6 in.)
Displacement	27 L (1649 cu. in.)
Aspiration	Turbocharged for ATAAC
Governor and Protection	Woodward PSG
Combustion	Rich Burn
Engine Weight, net dry (approx)	2141 kg (4720 lb)
Power Density	4.79 kg/kW (7.86 lb/bhp)
Power per Displacement	22.20 bhp/L
Engine Only Cooling System Capacity ...	75.7 L (20 gal)
Lube Oil System (refill)	170.3 L (45 gal)
Oil Change Interval	750 hours
Rotation (from flywheel end)	Counterclockwise
Flywheel and Flywheel Housing	SAE No. 0
Flywheel Teeth	136

FEATURES

Engine Design

- Improved reliability and durability
- Ability to burn a wide spectrum of gaseous fuels
- Robust diesel strength design prolongs life and lowers owning and operating costs
- Broad operating speed range

Full Range of Attachments

Large variety of factory-installed engine attachments reduces packaging time

Testing

Every engine is full-load tested to ensure proper engine performance.

Gas Engine Rating Pro

GERP is a PC-based program designed to provide site performance capabilities for Cat® natural gas engines for the gas compression industry. GERP provides engine data for your site's altitude, ambient temperature, fuel, engine coolant heat rejection, performance data, installation drawings, spec sheets, and pump curves.

Product Support Offered Through Global Cat Dealer Network

More than 2,200 dealer outlets

Cat factory-trained dealer technicians service every aspect of your petroleum engine

Cat parts and labor warranty

Preventive maintenance agreements available for repair-before-failure options

S•O•SSM program matches your oil and coolant samples against Caterpillar set standards to determine:

- Internal engine component condition
- Presence of unwanted fluids
- Presence of combustion by-products
- Site-specific oil change interval

Over 80 Years of Engine Manufacturing Experience

Over 60 years of natural gas engine production

Ownership of these manufacturing processes enables Caterpillar to produce high quality, dependable products.

- Casts engine blocks, heads, cylinder liners, and flywheel housings
- Machines critical components
- Assembles complete engine

Web Site

For all your petroleum power requirements, visit www.catoilandgas.cat.com.

STANDARD EQUIPMENT

Air Inlet System

Air cleaner — single element with service indicator

Control SystemGovernor — Woodward PSG mechanical
Governor control — positive locking**Cooling System**Thermostats and housing
Jacket water pump
Aftercooler water pump
Aftercooler core**Exhaust System**Watercooled exhaust manifolds
Dry exhaust elbow**Flywheel & Flywheel Housing**SAE No. 0 flywheel
SAE No. 0 flywheel housing
SAE standard rotation**Fuel System**Gas pressure regulator
Natural gas carburetor**Ignition System**

Digital ignition system

Instrumentation

Service meter

Lube SystemCrankcase breather — top mounted
Oil cooler
Oil filter — RH
Auxiliary oil reservoir
Rear sump oil pan
Oil filler in valve cover and dipstick — RH**Mounting System**

Engine supports

Protection System

Shutoff

GeneralPaint — Cat yellow
Crankshaft vibration damper and drive pulleys
Lifting eyes**OPTIONAL EQUIPMENT**

Air Inlet SystemAir cleaner
Air inlet adapter
Precleaner
Air cleaner rain cap**Charging System**Battery chargers
Charging alternators
Ammeter gauge
Ammeter gauge and wiring
Control mounting**Control System**EG3P/2301A speed control governor
PSG electric governor
PSG pneumatic governor**Cooling System**Radiators
Blower fan and fan drives for customer supplied radiators
ATAAC conversion
Aftercooler
Expansion tank
Heat exchanger**Exhaust System**Flexible fittings
Elbows
Flanges
Rain caps
Mufflers**Fuel System**Dual gas regulator
Low energy fuel carburetor
Low pressure gas conversion
Propane and natural gas valve and jet kits
Fuel filter**Ignition System**CSA ignition
Ignition ground wiring harness
Power supply — digital ignition system**Instrumentation**Alarm module
Gauges and instrument panels**Lube System**Auxiliary oil reservoir removal
Lubricating oil**Mounting System**

Vibration isolators

Power Take-OffsAuxiliary drive pulleys
Enclosed clutch
Clutch support
Front stub shaft
Flywheel stub shaft
Pulley removal**Protection System**Gas valves
Status control box interconnect wiring harness**Starting System**Air starting motor
Electric air start control
Air pressure regulator
Air silencer
Electric starting motors — single 24-volt
Starting aids
Battery sets (24-volt dry), cables, and rack**General**Tool set
Digital diagnostic tool

TECHNICAL DATA
G3412 Gas Petroleum Engine — 1500 & 1800 rpm

		DM8646-00	DM5206-04	DM5101-01
Engine Power				
@ 100% Load	bkW (bhp)	373 (500)	447 (600)	272 (365)
@ 75% Load	bkW (bhp)	280 (375)	336 (450)	204 (274)
Engine Speed				
	rpm	1500	1800	1800
Max Altitude @ Rated Torque and 38°C (100°F)	m (ft)	304.8 (1000)	609.6 (2000)	0
Speed Turndown @ Max Altitude, Rated Torque, and 38°C (100°F)	%	13.5	22	0
SCAC Temperature				
	°C (°F)	54 (130)	54 (130)	N/A
Emissions*				
NOx	g/bkW-hr (g/bhp-hr)	19.07 (14.22)	31.2 (23.27)	17.9 (13.35)
CO	g/bkW-hr (g/bhp-hr)	19.04 (14.2)	2.14 (1.6)	17.9 (13.35)
CO ₂	g/bkW-hr (g/bhp-hr)	609 (454)	635 (437)	—
VOC**	g/bkW-hr (g/bhp-hr)	0.35 (0.26)	0.15 (0.11)	—
Fuel Consumption***				
@ 100% Load	MJ/bkW-hr (Btu/bhp-hr)	11.04 (7800)	10.2 (7210)	11.10 (7847)
@ 75% Load	MJ/bkW-hr (Btu/bhp-hr)	11.27 (7964)	11.05 (7813)	12.15 (8589)
Heat Balance				
Heat Rejection to Jacket Water				
@ 100% Load	bkW (Btu/min)	399.05 (22,714)	393 (22,333)	270.6 (15,390)
@ 75% Load	bkW (Btu/min)	319.7 (18,197)	368 (20,935)	245.3 (13,946)
Heat Rejection to Aftercooler				
@ 100% Load	bkW (Btu/min)	7.92 (451)	41.2 (2343)	N/A
@ 75% Load	bkW (Btu/min)	3.04 (173)	208 (1639)	N/A
Heat Rejection to Exhaust				
@ 100% Load	bkW (Btu/min)	254.01 (14,458)	285 (16,234)	219.9 (12,506)
@ 75% Load	bkW (Btu/min)	187.09 (10,649)	208 (11,835)	173.1 (9,843)
Exhaust System				
Exhaust Gas Flow Rate				
@ 100% Load	m ³ /min (cfm)	59.55 (2103)	69.97 (2471)	49.16 (1736)
@ 75% Load	m ³ /min (cfm)	44.77 (1581)	51.71 (1826)	39.4 (1391)
Exhaust Stack Temperature				
@ 100% Load	°C (°F)	523.33 (974)	510 (950)	622.2 (1152)
@ 75% Load	°C (°F)	496.11 (925)	480 (896)	598.3 (1109)
Intake System				
Air Inlet Flow Rate				
@ 100% Load	m ³ /min (scfm)	19.85 (701)	23.87 (843)	14.6 (515)
@ 75% Load	m ³ /min (scfm)	15.46 (546)	18.24 (644)	12.01 (424)
Gas Pressure				
	kPag (psig)	137.9-172.4 (20-25)	137.9-172.4 (20-25)	10-35 (1.5-5)

*at 100% load and speed, all values are listed as not to exceed

**Volatile organic compounds as defined in U.S. EPA 40 CFR 60, subpart JJJJ

***ISO 3046/1

GAS PETROLEUM ENGINE

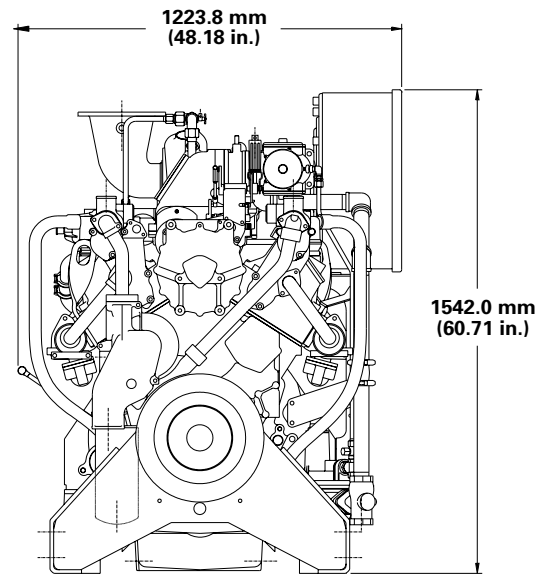
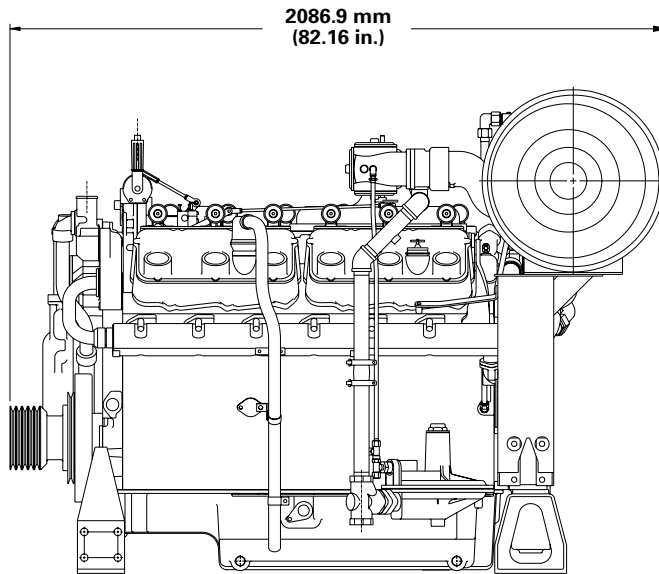

PACKAGE DIMENSIONS

Length	mm (in.)	2086.9 (82.16)
Width	mm (in.)	1223.8 (48.18)
Height	mm (in.)	1542.0 (60.71)
Shipping Weight	kg (lb)	2141 (4720)

Note: General configuration not to be used for installation. See general dimension drawings for detail.

RATING DEFINITIONS AND CONDITIONS

Engine performance is obtained in accordance with SAE J1995, ISO3046/1, BS5514/1, and DIN6271/1 standards.

Transient response data is acquired from an engine/generator combination at normal operating temperature and in accordance with ISO3046/1 standard ambient conditions. Also in accordance with SAE J1995, BS5514/1, and DIN6271/1 standard reference conditions.

Conditions: Power for gas engines is based on fuel having an LHV of 33.74 kJ/L (905 Btu/cu ft) at 101 kPa (29.91 in. Hg) and 15° C (59° F). Fuel rate is based on a cubic meter at 100 kPa (29.61 in. Hg) and 15.6° C (60.1° F). Air flow is based on a cubic foot at 100 kPa (29.61 in. Hg) and 25° C (77° F). Exhaust flow is based on a cubic foot at 100 kPa (29.61 in. Hg) and stack temperature.

Materials and specifications are subject to change without notice. The International System of Units (SI) is used in this publication. CAT, CATERPILLAR, their respective logos, S•O•S, "Caterpillar Yellow" and the "Power Edge" trade dress, as well as corporate and product identity used herein, are trademarks of Caterpillar and may not be used without permission.