

# C18 ACERT®

## MARINE PROPULSION ENGINE

1150 mhp (1135 bhp) 847 bkW

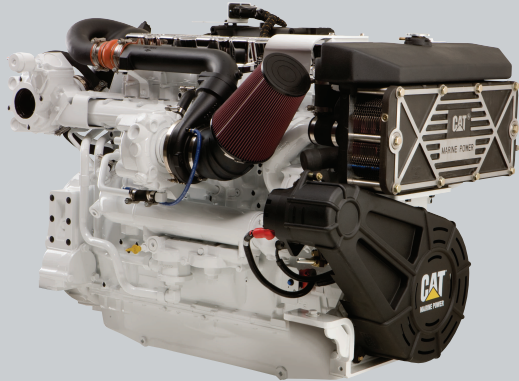

Image shown may not reflect actual engine

# CATERPILLAR®

## STANDARD ENGINE EQUIPMENT

- MEUI fuel system
- Corrosion resistant aftercooler core
- Light duty air cleaner (open system)
- Titanium plate heat exchanger with expansion tank
- Coolant recovery system
- Thermostat and housing
- Watercooled exhaust manifold and turbocharger
- Round flanged outlet
- 24V instrument panel
- Crankcase breather
- Engine oil cooler and oil filler
- Shallow oil pan
- Front support adjustable mounting system
- SAE A hydraulic pump drive
- Two-groove crankshaft pulley
- Vibration damper and guard
- Customer wiring and service tool connector
- Flexible fuel lines

## SPECIFICATIONS

### I-6, 4-Stroke-Cycle-Diesel

- EPA Tier 2 Recreational/IMO compliant
- 18.1 L (1106 cu in) displacement
- 2300 rpm rated engine speed
- 145 mm (5.7 in) bore x 183 mm (7.2 in) stroke
- Turbocharged and aftercooled aspiration
- Electronically governed
- Heat exchanger cooled
- Refill capacity
  - Cooling system: 45 L (12 gal)
  - Lube oil system: 49 L (13 gal)
- SAE No. 1 flywheel and flywheel housing
- 113 flywheel teeth
- Counterclockwise rotation from flywheel end
- 250-hour oil change interval
- Caterpillar Diesel Engine Oil 10W30 or 15W40

## DIMENSIONS

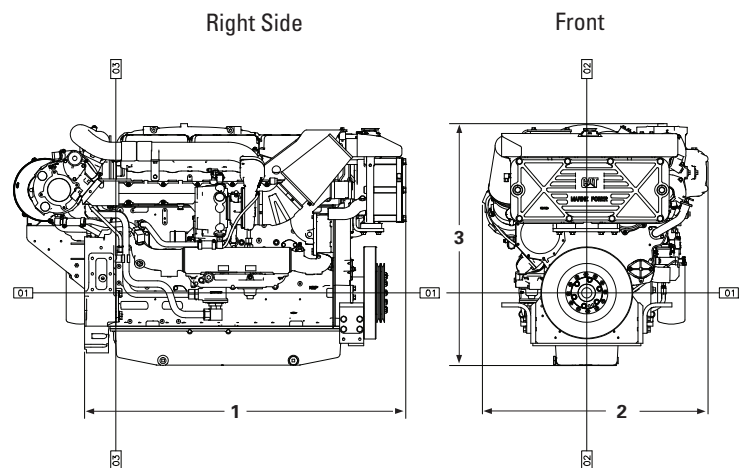

### ENGINE DIMENSIONS & WEIGHT

<b>(1) Length to Flywheel Housing</b>	1591 mm	62.64 in.
<b>(2) Width</b>	1118 mm	44.02 in.
<b>(3) Height</b>	1199.2 mm	47.21 in.
<b>Weight, Net Dry (approx)</b>	1860 kg	4,102 lb

Note: Do not use these dimensions for installation design. See general dimension drawings for detail (Drawing #2070024). For complete information, please refer to Spec Sheet Wizard.

## MARINE ENGINE PERFORMANCE

### C18 TA

847 kW (1136 bhp) @ 2300 rpm  
E Rating (High Performance) — EM0012-01

EPA T2R/EU Stage IIIA

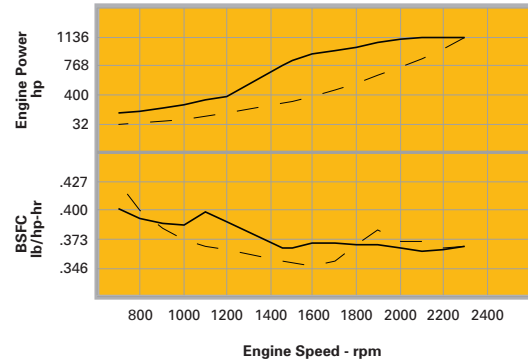
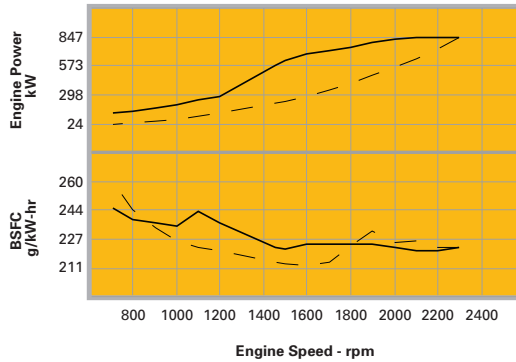

**Metric** Maximum Power Prop Demand   **847 kW**

**English** Maximum Power Prop Demand   **1136 hp**

#### Performance Data

	Engine Speed rpm	Engine Power kW	BSFC g/kW-hr	Fuel Rate L/hr
<b>Maximum Power Data</b>	2300	847.0	222.7	224.8
	2200	847.0	220.3	222.5
	2100	847.0	219.8	221.9
	1900	797.0	224.2	213.0
	1800	755.0	224.2	201.8
	1600	684.0	224.7	183.2
	1500	618.0	221.1	162.9
	1200	288.0	237.0	81.4
	1000	201.0	235.1	56.3
	800	144.0	238.6	41.0
700	120.0	244.6	35.0	
<b>Prop Demand Data</b>	2300	847.0	222.7	224.8
	2200	741.3	221.9	196.0
	2100	644.7	226.2	173.9
	1900	477.5	232.4	132.3
	1800	406.0	223.9	108.4
	1600	285.1	211.3	71.8
	1500	234.9	212.6	59.5
	1200	120.3	220.0	31.5
	1000	69.6	226.8	18.8
	800	35.6	243.8	10.4
700	23.9	259.9	7.4	

Cubic prop demand curve with 3.0 exponent for displacement hulls only.

#### Performance Data

	Engine Speed rpm	Engine Power hp	BSFC lb/hp-hr	Fuel Rate gph
<b>Maximum Power Data</b>	2300	1135.8	.366	59.4
	2200	1135.8	.362	58.8
	2100	1135.8	.361	58.6
	1900	1068.8	.369	56.3
	1800	1012.5	.369	53.3
	1600	917.3	.369	48.4
	1500	828.8	.363	43.0
	1200	386.2	.390	21.5
	1000	269.5	.387	14.9
	800	193.1	.392	10.8
700	160.9	.402	9.2	
<b>Prop Demand Data</b>	2300	1135.8	.366	59.4
	2200	994.1	.365	51.8
	2100	864.6	.372	45.9
	1900	640.3	.382	34.9
	1800	544.5	.368	28.6
	1600	382.3	.347	19.0
	1500	315.0	.350	15.7
	1200	161.3	.362	8.3
	1000	93.3	.373	5.0
	800	47.7	.401	2.7
700	32.1	.427	2.0	

Power produced at the flywheel will be within standard tolerances up to 50°C (122°F) combustion air temperature measured at the air cleaner inlet, and fuel temperature up to 52°C (125°F) measured at the fuel filter base. Power rated in accordance with NMMA procedure as crankshaft power. Reduce crankshaft power by 3% for propeller shaft power.