

PRIME 60 Hz, 1800 rpm

SPECIFICATIONS



Image is a representation only, and may not show optional attachments.

I-6, 4-Stroke-Cycle-Diesel

Emissions EPA Tier 2 compliant, IMO certified
Displacement 18.1 L (1106 cu. in.)
Rated Engine Speed 1800 rpm
Bore 145 mm (5.71 in.)
Stroke 183 mm (7.2 in.)
Aspiration Turbocharged-Aftercooled
Governor Electronic (A4)
Cooling System Heat Exchanger
Weight, Net Dry (approx) . 1802-2070 kg (3974-4565 lbs)
Refill Capacity
Cooling System 45 L (12 gal)
Lube Oil System 49 L (13 gal)
Oil Change Interval 250 hr
Rotation (from flywheel end) Counterclockwise
Flywheel and flywheel housing SAE No. 0
Flywheel Teeth 136
Max. Exhaust Backpressure 10 kPa (40 in. water)

STANDARD EQUIPMENT

Air Inlet System

Corrosion-resistant sea water aftercooler core, air cleaner/fumes disposal (closed system), jacket water cooled turbocharger, turbocharger inlet OD straight connection

Control System

Electronic governing (A4 ECU), electronic throttle position sensor, programmable low idle, electronic diagnostics and fault logging, fuel/air ratio control

Cooling System

Gear-driven jacket water pump, block heater, 1500W, 120V AC current; gear-driven, bronze impeller, sea water pump; separate circuit keel cooling or titanium plate heat exchanger (with expansion tank and coolant recovery system)

Exhaust System

Watercooled exhaust manifold and turbocharger, ID round-flanged outlet

Fuel System

Fuel filter, RH service on port, LH service on starboard; fuel transfer pump; fuel priming pump; flexible fuel lines

Lube System

Crankcase breather; oil cooler; oil filler; spin-on oil filter, RH or LH service; center sump shallow oil pan; dipstick, RH service on port, LH service on starboard; gear-driven oil pump

Mounting System

Front support — adjustable

Power Take-Offs

Hydraulic pump drive, SAE A, 11 tooth spline, 46 ft-lbs. max. torque, counterclockwise as viewed from the front of the engine looking into the drive, turning 1.41 times engine speed; crankshaft pulley, 292 mm (11.5 in) two-groove, 15.88 mm (.63 in) wide

Protection System

Shutdown — electronic, 12 or 24V

General

Torsional vibration damper, lifting eyes, variable engine wiring, RH or LH service options, literature, upper rear-facing customer wiring connector, service tool connection, electronic installation kit

ISO Certification

Factory-designed systems built at Caterpillar ISO 9001:2000 certified facilities.

OPTIONAL ATTACHMENTS

Air Inlet System

Aftercooler condensate drain

Charging System

Battery charger, 10 amp; charging alternators, 24V, 60 amp, RH or LH; ammeter gauge, 24V

Exhaust System

Dry elbows, watercooled elbows, flexible fitting, exhaust outlet flange

Fuel System

Fuel cooler, duplex fuel filter, primary fuel/water separator

Instrumentation

Wiring for multiple stations of Marine Power Display (MPD); gauges and instrument panels; wiring group (MPD); digital tachometer, magnetic pickup; MPD system

Lube System

Manual sump pumps, duplex oil filters, deep sump oil pan

Power Take-Offs

Crankshaft pulleys and damper, stub shafts

Starting System

Air starting motor, air start accessories (air pressure regulator and air start silencer), electric starting motors, jacket water heater — 240V, battery sets — 24V (dry)

General

Bilge pump drive, damper guards, tool set, wiring harness removal, filter cover kit, tool set

Literature

Optional literature (other languages than English), extra literature (English and other languages)

Packing

Overseas preservation, engine protective cover, storage preservation, export packing

PERFORMANCE DATA

601 bkW (806 bhp) @ 1800 rpm
MA Rating — DM9678-00

IMO Tier 2 Certified

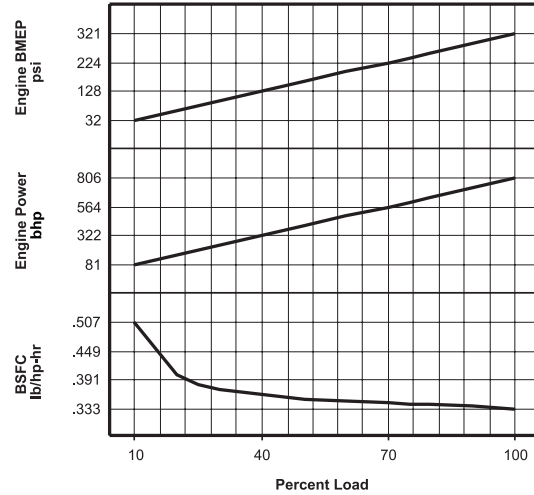
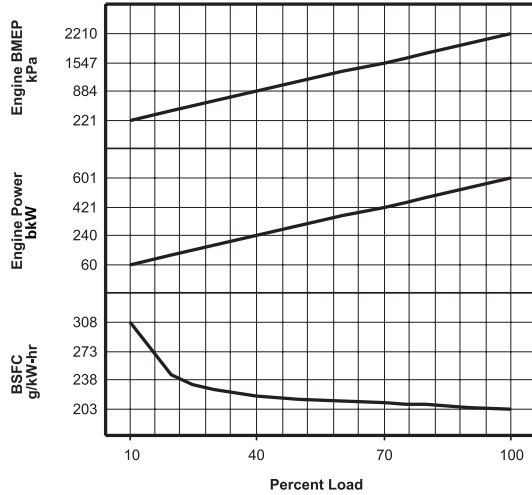

Engine Power bkW	Percent Load	Engine BMEP kPa	BSFC g/kWh-hr	Fuel Rate L/hr
601.0	100	2210	203	145.1
540.9	90	1989	205	132.2
480.8	80	1768	208	119.1
450.8	75	1657	209	112.2
420.7	70	1547	210	105.3
360.6	60	1326	212	91.2
300.5	50	1105	215	77.0
240.4	40	884	219	62.8
180.3	30	663	226	48.6
150.3	25	552	233	41.7
120.2	20	442	245	35.0
60.1	10	221	308	22.1

Engine Power bhp	Percent Load	Engine BMEP psi	BSFC lb/hp-hr	Fuel Rate gph
806.0	100	321	.333	38.3
725.4	90	288	.337	34.9
644.8	80	256	.342	31.5
604.5	75	240	.343	29.6
564.2	70	224	.345	27.8
483.6	60	192	.349	24.1
403.0	50	160	.354	20.3
322.4	40	128	.360	16.6
241.8	30	96	.372	12.8
201.6	25	80	.383	11.0
161.2	20	64	.402	9.2
80.6	10	32	.507	5.8

Engine Power bkW	Intake Manifold Temp °C	Intake Manifold Pressure kPa	Intake Air Flow m³/min	Exh Manifold Temp °C	Exh Stk Temp °C	Exh Gas Flow m³/min
601.0	41.0	198.7	41.90	634.7	414.9	102.10
540.9	40.1	184.0	40.00	612.5	402.6	95.60
480.8	39.1	168.3	37.90	590.2	390.4	88.80
450.8	38.4	157.8	36.50	578.5	384.3	84.70
420.7	37.8	146.9	35.00	566.4	378.3	80.50
360.6	36.6	123.8	31.80	540.6	366.2	71.50
300.5	35.6	98.7	28.10	509.7	350.9	61.60
240.4	34.8	73.4	24.40	469.8	329.4	51.60
180.3	34.0	48.1	20.70	421.1	301.9	41.60
150.3	33.6	37.1	19.00	391.0	283.4	37.00
120.2	33.2	28.8	17.80	354.9	259.3	33.10
60.1	32.4	15.4	15.90	271.6	201.8	26.10

Engine Power bhp	Intake Manifold Temp °F	Intake Manifold Pressure in-hg	Intake Air Flow cfm	Exh Manifold Temp °F	Exh Stk Temp °F	Exh Gas Flow cfm
806.0	105.8	58.8	1479.69	1174.5	778.8	3605.63
725.4	104.2	54.5	1412.59	1134.5	756.7	3376.09
644.8	102.4	49.8	1338.43	1094.4	734.7	3135.95
604.5	101.1	46.7	1288.99	1073.3	723.7	2991.16
564.2	100.0	43.5	1236.02	1051.5	712.9	2842.83
483.6	97.9	36.7	1123.01	1005.1	691.2	2525.00
403.0	96.1	29.2	992.34	949.5	663.6	2175.39
322.4	94.6	21.7	861.68	877.6	624.9	1822.24
241.8	93.2	14.2	731.01	790.0	575.4	1469.09
201.6	92.5	11.0	670.98	735.8	542.1	1306.64
161.2	91.8	8.5	628.60	670.8	498.7	1168.92
80.6	90.3	4.6	561.50	520.9	395.2	921.71

Heat Rejection Data

Engine Power bkW	Percent Load	Rej to JW kW	Rej to Atmos kW	Rej to Exh kW	From Oil Clr kW
601.0	100	309.0	99.4	431.0	77.9
540.9	90	281.0	94.4	395.0	70.8
480.8	80	254.0	86.8	359.0	63.6
450.8	75	240.0	84.3	339.0	59.9
420.7	70	227.0	81.6	318.0	56.2
360.6	60	201.0	75.3	277.0	48.7
300.5	50	176.0	70.0	233.0	41.1
240.4	40	150.0	63.0	188.0	33.5
180.3	30	125.0	52.4	144.0	25.9
150.3	25	112.0	47.2	123.0	22.2
120.2	20	97.0	43.9	103.0	18.7
60.1	10	71.0	33.4	67.0	11.8

Heat Rejection Data

Engine Power bhp	Percent Load	Rej to JW Btu/min	Rej to Atmos Btu/min	Rej to Exh Btu/min	From Oil Clr Btu/min
806.0	100	17572.8	5652.9	24510.9	4430.2
725.4	90	15980.4	5368.5	22463.6	4026.4
644.8	80	14445.0	4936.3	20416.3	3616.9
604.5	75	13648.8	4794.1	19278.9	3406.5
564.2	70	12909.5	4640.6	18084.6	3196.1
483.6	60	11430.9	4282.3	15753.0	2769.6
403.0	50	10009.1	3980.9	13250.7	2337.4
322.4	40	8530.5	3582.8	10691.5	1905.1
241.8	30	7108.7	2980.0	8189.3	1472.9
201.6	25	6369.4	2684.3	6995.0	1262.5
161.2	20	5516.4	2496.6	5857.6	1063.5
80.6	10	4037.8	1899.5	3810.3	671.1

DIMENSIONS

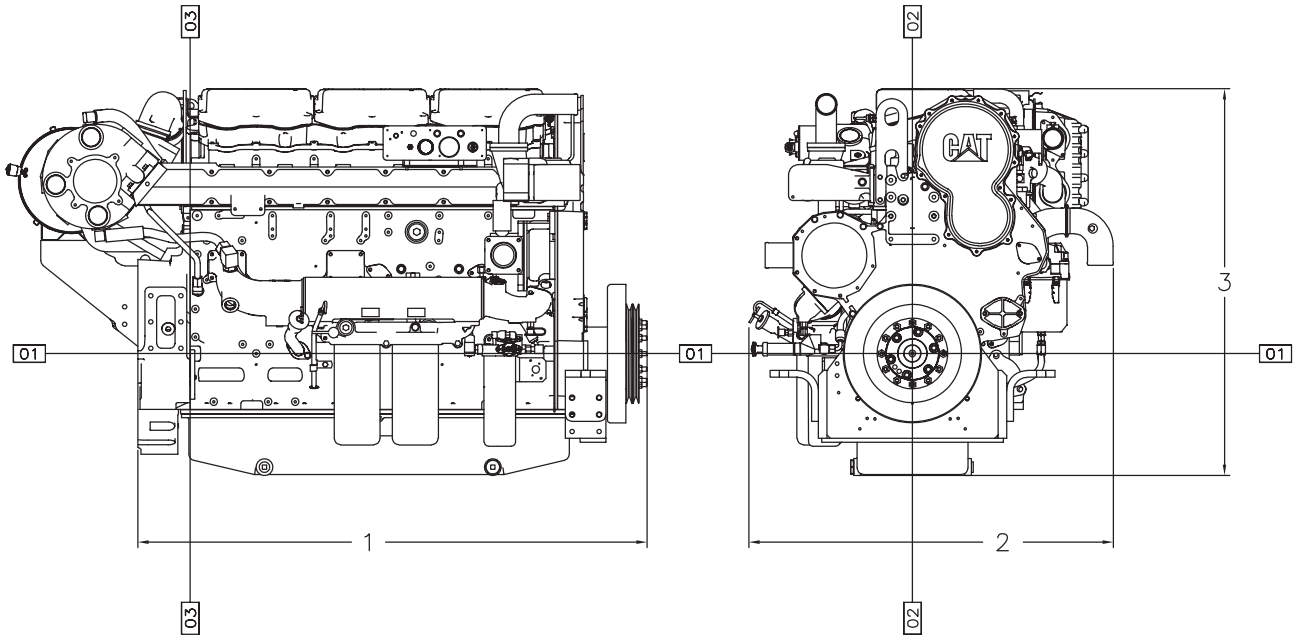

Engine Dimensions (approximate)		
(1) Length (flywheel housing)	1506 mm	59.23 in
(2) Width	1078 mm	42.44 in
(3) Height	1145 mm	45.08 in
Weight, Net Dry (approx)	1802-2070 kg	3974-4565 lb

Note: Do not use for installation design.



C18 ACERT MARINE AUXILIARY/GEN SET ENGINE

601 bkW (806 bhp)

RATING CONDITIONS

Power at declared engine speed is in accordance with ISO3046-1:2002E. Caterpillar maintains ISO9001:1994/QS-9000 approved engine test facilities to assure accurate calibration of test equipment. Electronically controlled engines are set at the factory at the advertised power corrected to standard ambient conditions. The published fuel consumption rates are in accordance with ISO3046-1:2002E.

Fuel rates are based on fuel oil of 35° API [16°C (60°F)] gravity having an LHV of 42 780 kJ/kg (18,390 Btu/lb) when used at 29°C (85°F) and weighing 838.9 g/L (7.001 lb/U.S. gal). Additional ratings may be available for specific customer requirements. Consult your Caterpillar representative for additional information.

Performance data is calculated in accordance with tolerances and conditions stated in this specification sheet and is only intended for purposes of comparison with other manufacturers' engines. Actual engine performance may vary according to the particular application of the engine and operating conditions beyond Caterpillar's control.

Power produced at the flywheel will be within standard tolerances up to 49°C (120°F) combustion air temperature measured at the air cleaner inlet, and fuel temperature up to 52°C (125°F) measured at the fuel filter base. Power rated in accordance with NMMA procedure as crankshaft power. Reduce crankshaft power by 3% for propeller shaft power.

CAT, CATERPILLAR, their respective logos, "Caterpillar Yellow" and the POWER EDGE trade dress, as well as corporate and product identity used herein, are trademarks of Caterpillar and may not be used without permission.