

May not represent actual engine

## SPECIFICATIONS

### In-Line 6, 4-Stroke-Cycle-Diesel

Emissions	IMO II/EPA Tier 2 Compliant
Bore	280 mm (11.0 in.)
Stroke	300 mm (11.8 in.)
Displacement	111 L (6,773 cu. in.)
Rotation (from flywheel end)	Counterclockwise
Compression Ratio	13:1
Aspiration	Turbocharged-Aftercooled
Governor	Electronic
Low Idle Speed	350 rpm
Rated Speed	900 rpm
Oil Change Interval*	1025 hr
Serial Number Prefix	SCB
Cooling System	Keel or Heat Exchanger
Refill Capacities	
Cooling System	900-1075 L (238-284 gal)
Lube Oil System	697 L (184 gal)

\*A new S•O•S<sup>SM</sup> analysis must be done to determine actual oil change intervals.

## STANDARD ENGINE EQUIPMENT

### Air Inlet System

Aftercooler — fresh water, corrosion resistant coated (air side); air inlet shutoff; breather — crankcase, top-mounted; turbocharger — engine oil lubricated

### Control System

Single ADEM™ A3 electronic control unit (ECU) with electronic unit injector fuel system, rigid wiring harness (10 amp, 24 volt power required to drive ECUs)

### Cooling System

Engine coolant water drains

### Exhaust System

Dry, gas tight, exhaust manifold

### Fuel System

Distillate fuel (requires viscosity ranging from 1.4 cSt to 20 cSt at 38° C), fuel transfer pump (mounted on left-hand side), duplex fuel filters, electronically controlled unit injectors

### Lube Oil System

Centrifugal oil filters with single shutoff, service side engine mounted on cylinder block inspection covers includes installed oil lines and single shutoff valve, filters centrifuge bypass oil from the main lubricating oil pump, can be serviced with the engine running, oil filler and dipstick valve, oil pressure regulating valves, crankcase explosion relief valves

### General

Cat® yellow paint; gear-driven pumps: fuel, oil, jacket water, aftercooler/oil cooler water; service literature

Factory-designed systems built at Caterpillar ISO 9001:2000 certified facilities.

### MARINE ENGINE PERFORMANCE

## C280-6

### DIESEL ENGINE TECHNICAL DATA



<b>Genset</b>	<b>50 Hz</b>	<b>RATING:</b>	Marine Aux - Prime
ENGINE SPEED (rpm):	1000	<b>CERTIFICATION:</b>	IMO II/EPA MARINE TIER II
COMPRESSION RATIO:	13:1	<b>TURBOCHARGER PART #:</b>	189-4427
AFTERCOOLER WATER (°C):	32	<b>FUEL TYPE:</b>	Distillate
JACKET WATER OUTLET (°C):	90	<b>RATED ALTITUDE @ 25°C (m):</b>	150
IGNITION SYSTEM:	EUI	<b>ASSUMED GENERATOR EFFICIENCY (%):</b>	96
EXHAUST MANIFOLD:	DRY	<b>ASSUMED GENERATOR POWER FACTOR:</b>	0.8
FIRING PRESSURE, MAXIMUM (kPa)	17300	<b>MEAN PISTON SPEED (m/s):</b>	10

RATING		NOTES	LOAD	110%	100%	75%	50%
ENGINE POWER		(2)	bkW	2233	2030	1523	1015
GENERATOR POWER		(2)	ekW	2144	1949	1462	974
BMEP			kPa	2418	2198	1649	1099
ENGINE EFFICIENCY	(ISO 3046/1)	(1)	%	42.0%	42.1%	39.6%	38.6%
ENGINE EFFICIENCY	(NOMINAL)	(1)	%	40.8%	40.8%	38.4%	37.4%

ENGINE DATA							
FUEL CONSUMPTION	(ISO 3046/1)	(1)	g/bkW-hr	201.5	201.2	213.9	220.1
FUEL CONSUMPTION	(NOMINAL)	(1)	g/bkW-hr	205.4	205.1	218.0	224.4
FUEL CONSUMPTION	(90% CONFIDENCE)	(1)	g/bkW-hr	207.5	207.3	220.5	227.2
AIR FLOW (@ 25°C, 101.3 kPaa)			Nm <sup>3</sup> /min	218.0	204.9	178.3	128.5
AIR MASS FLOW			kg/hr	14594	13713	11937	8598
INLET MANIFOLD PRESSURE			kPa (abs)	372.5	349.2	302.0	218.2
INLET MANIFOLD TEMPERATURE			°C	44.0	43.0	40.0	37.0
EXHAUST STACK TEMPERATURE			°C	391.6	376.9	373.4	368.1
EXHAUST GAS FLOW (@ stack temp, 101.3 kPa)			m <sup>3</sup> /min	455.7	425.8	363.9	261.6
EXHAUST GAS MASS FLOW			kg/hr	14601	13720	11942	8602

EMISSIONS "NOT TO EXCEED DATA"							
Nox as NO <sub>2</sub> + THC (molecular weight of 13.018)			g/bkW-hr	10.90	8.78	9.93	9.50
Nox as NO <sub>2</sub>			g/bkW-hr	10.11	7.87	8.84	8.07
CO			g/bkW-hr	0.84	0.56	0.78	1.10
THC (molecular weight of 13.018)			g/bkW-hr	0.78	0.91	1.10	1.43
Particulates			g/bkW-hr	0.16	0.19	0.31	0.89

EMISSIONS "NOMINAL DATA"							
NO <sub>x</sub> (as NO) + THC (molecular weight of 13.018)			g/bkW-hr	9.40	7.54	8.53	8.11
NO <sub>x</sub> (as NO)			g/bkW-hr	8.79	6.84	7.68	7.01
CO			g/bkW-hr	0.64	0.43	0.60	0.84
THC (molecular weight of 13.018)			g/bkW-hr	0.60	0.70	0.84	1.10
Particulates			g/bkW-hr	0.12	0.14	0.22	0.63

ENERGY BALANCE DATA							
FUEL INPUT ENERGY (LHV)	(NOMINAL)	(1)	KW	5478	4973	3964	2712
HEAT REJ. TO JACKET WATER	(NOMINAL)	(3)	KW	436	404	330	257
HEAT REJ. TO ATMOSPHERE	(NOMINAL)	(4)	KW	110	99	79	54
HEAT REJ. TO OIL COOLER	(NOMINAL)	(5)	KW	224	213	189	164
HEAT REJ. TO EXH. (LHV to 25°C)	(NOMINAL)	(3)	KW	1724	1562	1338	959
HEAT REJ. TO EXH. (LHV to 177°C)	(NOMINAL)	(3)	KW	1221	1187	1035	763
HEAT REJ. TO AFTERCOOLER	(NOMINAL)	(6) (7)	KW	740	653	498	260

#### CONDITIONS AND DEFINITIONS

ENGINE RATING OBTAINED AND PRESENTED IN ACCORDANCE WITH ISO 3046/1 AND SAE J1995 JAN90 STANDARD REFERENCE CONDITIONS OF 25°C, 100 KPA, 30% RELATIVE HUMIDITY AND 150M ALTITUDE AT THE STATED AFTERCOOLER WATER TEMPERATURE CONSULT ALTITUDE CURVES FOR APPLICATIONS ABOVE MAXIMUM RATED ALTITUDE AND/OR TEMPERATURE PERFORMANCE AND FUEL CONSUMPTION ARE BASED ON 35 API, 16°C FUEL HAVING A LOWER HEATING VALUE OF 42.780 KJ/KG USED AT 29°C WITH A DENSITY OF 838.9 G/LITER

#### NOTES

- 1) FUEL CONSUMPTION TOLERANCE. ISO 3046/1 IS 0, + 5% OF FULL LOAD DATA. NOMINAL IS ± 3 % OF FULL LOAD DATA
- 2) ENGINE POWER TOLERANCE IS ± 3 % OF FULL LOAD DATA.
- 3) HEAT REJECTION TO JACKET AND EXHAUST TOLERANCE IS ± 10% OF FULL LOAD DATA. (heat rate based on treated water)
- 4) HEAT REJECTION TO ATMOSPHERE TOLERANCE IS ±50% OF FULL LOAD DATA. (heat rate based on treated water)
- 5) HEAT REJECTION TO LUBE OIL TOLERANCE IS ± 20% OF FULL LOAD DATA. (heat rate based on treated water)
- 6) HEAT REJECTION TO AFTERCOOLER TOLERANCE IS ± 5% OF FULL LOAD DATA. (heat rate based on treated water)
- 7) TOTAL AFTERCOOLER HEAT = AFTERCOOLER HEAT x ACHRF (heat rate based on treated water)
- 8) FUEL CONSUMPTION DATA IS WITHOUT SEA WATER PUMP.

### MARINE ENGINE PERFORMANCE

#### C280-6

#### DIESEL ENGINE TECHNICAL DATA



##### ALTITUDE DERATION FACTORS

AIR TO TURBO (°C)	50	0.94	0.91	0.88	0.86	0.83	0.81	0.78	0.76	0.74	0.71	0.69	0.67	0.65
	45	0.95	0.93	0.90	0.87	0.85	0.82	0.80	0.77	0.75	0.73	0.70	0.68	0.66
	40	0.97	0.94	0.91	0.89	0.86	0.83	0.81	0.78	0.76	0.74	0.71	0.69	0.67
	35	0.98	0.96	0.93	0.90	0.87	0.85	0.82	0.80	0.77	0.75	0.73	0.70	0.68
	30	1.00	0.97	0.94	0.92	0.89	0.86	0.84	0.81	0.79	0.76	0.74	0.71	0.69
	25	1.00	0.99	0.96	0.93	0.90	0.88	0.85	0.82	0.80	0.77	0.75	0.73	0.70
	20	1.00	1.00	0.98	0.95	0.92	0.89	0.86	0.84	0.81	0.79	0.76	0.74	0.72
	15	1.00	1.00	0.99	0.96	0.93	0.91	0.88	0.85	0.83	0.80	0.78	0.75	0.73
	10	1.00	1.00	1.00	0.98	0.95	0.92	0.89	0.87	0.84	0.82	0.79	0.77	0.74
			0	250	500	750	1000	1250	1500	1750	2000	2250	2500	2750

ALTITUDE (METERS ABOVE SEA LEVEL)

##### AFTERCOOLER HEAT REJECTION FACTORS

AIR TO TURBO	50	1.23	1.27	1.30	1.34	1.38	1.42	1.45	1.49	1.53	1.56	1.60	1.64	1.67
	45	1.18	1.22	1.25	1.29	1.32	1.36	1.39	1.43	1.46	1.50	1.53	1.57	1.61
	40	1.13	1.17	1.20	1.23	1.27	1.30	1.34	1.37	1.40	1.44	1.47	1.50	1.54
	35	1.08	1.12	1.15	1.18	1.21	1.24	1.28	1.31	1.34	1.37	1.41	1.44	1.47
	30	1.03	1.06	1.10	1.13	1.16	1.19	1.22	1.25	1.28	1.31	1.34	1.37	1.40
	25	1.00	1.01	1.04	1.07	1.10	1.13	1.16	1.19	1.22	1.25	1.28	1.31	1.34
	20	1.00	1.00	1.00	1.02	1.05	1.07	1.10	1.13	1.16	1.19	1.21	1.24	1.27
	15	1.00	1.00	1.00	1.00	1.00	1.02	1.04	1.07	1.10	1.12	1.15	1.18	1.20
	10	1.00	1.00	1.00	1.00	1.00	1.00	1.00	1.01	1.04	1.06	1.09	1.11	1.14
			0	250	500	750	1000	1250	1500	1750	2000	2250	2500	2750

ALTITUDE (METERS ABOVE SEA LEVEL)

##### FREE FIELD MECHANICAL NOISE

		<b>SOUND PRESSURE LEVEL dB(A)</b>												
DISTANCE FROM THE ENGINE (M)	15M	91	87.7	84.6	83.8	84.1	85.3	81	77	69				
	7M	97	93.7	90.6	89.8	90.1	91.3	87	83	75				
	1M	108	104.7	101.6	100.8	101.1	102.3	98	94	86				
		<b>Overall</b>	<b>63</b>	<b>125</b>	<b>250</b>	<b>500</b>	<b>1000</b>	<b>2000</b>	<b>4000</b>	<b>8000</b>				
		Octave Band (Hz)												

##### FREE FIELD EXHAUST NOISE

		<b>SOUND PRESSURE dB(A)</b>												
DISTANCE FROM THE ENGINE (M)	15M	96	107.1	104.6	95.4	91.5	86.7	87.2	85.2	80.9				
	7M	103	114.4	111.4	102.2	97.9	93.0	94.4	82.8	88.2				
	1.5M	116	127.4	125.0	114.9	111.4	107.0	108.5	106.1	100.8				
		<b>Overall</b>	<b>63</b>	<b>125</b>	<b>250</b>	<b>500</b>	<b>1000</b>	<b>2000</b>	<b>4000</b>	<b>8000</b>				
		Octave Band (Hz)												

##### TOTAL DERATION FACTORS:

This table shows the deration required for various air inlet temperatures and altitudes. Use this information to help determine actual engine power for your site. The total deration factor includes deration due to altitude and ambient temperature, and air inlet manifold temperature deration.

##### AFTERCOOLER HEAT REJECTION FACTORS:

Aftercooler heat rejection is given for standard conditions of 25°C and 150 m altitude. To maintain a constant air inlet manifold temperature, as the air to turbo temperature goes up, so must the heat rejection. As altitude increases, the turbocharger must work harder to overcome the lower atmospheric pressure. This increases the amount of heat that must be removed from the inlet air by the aftercooler. Use the aftercooler heat rejection factor to adjust for ambient and altitude conditions. Multiply this factor by the standard aftercooler heat rejection.

##### GENERATOR EFFICIENCY:

Generator power determined with an assumed generator efficiency of 96% [generator power = engine power x 0.96]. If the actual generator efficiency is less than 96% [and greater than 94.5%], the generator power [kW] listed in the technical data can still be achieved. The BSFC values must be increased by a factor.

The factor is a percentage = 96% - actual generator efficiency.

##### SOUND DATA:

Data determined by methods similar to ISO Standard DIS-8528-10. Accuracy Grade 3.

### DIMENSIONS

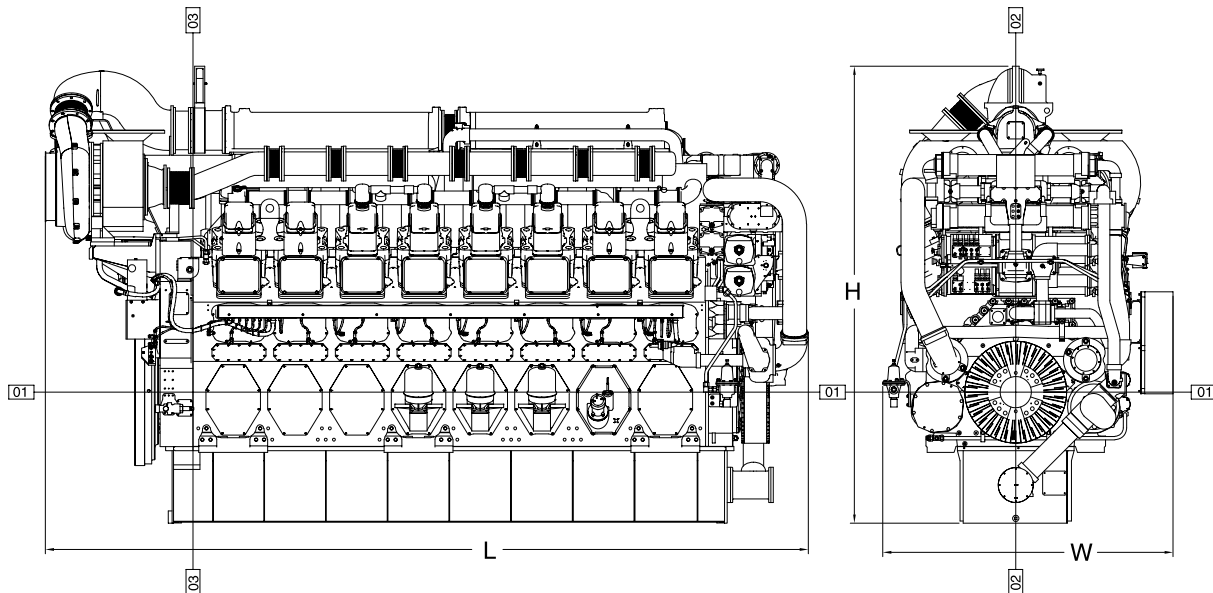

Engine Dimensions		
<b>Length of Engine</b>	3691 mm	145.0 in
<b>Length with Generator</b>	7120 mm	280.3 in
<b>Width of Engine</b>	1961 mm	70.7 in
<b>Height</b>	3934 mm	154.9 in
<b>Engine Weight – dry (approx.)</b>	15,680 kg	34,496 lb
<b>Generator Weight – (approx.)</b>	8165 kg	18,000 lb

### RATING DEFINITIONS AND CONDITIONS

**Prime Power** — 6,000 hrs./yr., for applications with load factors less than or equal to 60%. Rated load (100%) usage is limited to 1 hour in 12. 10% overload available.

**Ratings** are based on SAE J1995/ISO3046 standard conditions of 100 kPa (29.61 in. Hg), 25°C (77°F), and 30% relative humidity at the stated charge air cooler water temperature. Ratings also meet classification society maximum temperature requirements of 45°C (113°F) air temperature to the turbocharger and 32°C (90°F) seawater temperature without derate.

Additional ratings may be available for specific customer requirements. Consult your Cat representative for additional information.

**Fuel rates** are based on 35° API, 16°C (60°F) fuel used at 29°C (85°F) with a density of 838.9 g/liter (7.001 lbs/U.S. gal). Lower Heat Value (LHV) of 42 780 kJ/kg (18,390 Btu/lb). Tolerance is +5%. Includes all engine mounted pumps. BSFC without pumps is 3% less.

**Marine Certification** — Ratings are marine classification society approved by ABS, BV, CCS, DnV, GL, LRS, and RINA. These societies have also granted C280 factory line production approval which eliminates requirement for society surveyor witness test.

Performance data is calculated in accordance with tolerances and conditions stated in this specification sheet and is only intended for purposes of comparison with other manufacturers' engines. Actual engine performance may vary according to the particular application of the engine and operating conditions beyond Caterpillar's control.

Power produced at the flywheel will be within standard tolerances up to 49°C (120°F) combustion air temperature measured at the air cleaner inlet, and fuel temperature up to 52°C (125°F) measured at the fuel filter base. Power rated in accordance with NMMA procedure as crankshaft power. Reduce crankshaft power by 3% for propeller shaft power.

CAT, CATERPILLAR, their respective logos, ADEM, S•O•S, "Caterpillar Yellow" and the "Power Edge" trade dress, as well as corporate and product identity used herein, are trademarks of Caterpillar and may not be used without permission.