

C32 ACERT™

MARINE PROPULSION ENGINE

850 bhp 634 kW WOSR 1800-2100 rpm
1200 bhp 894 kW WOSR 1800-2100 rpm



Image shown
may not reflect
actual engine



STANDARD ENGINE EQUIPMENT

- Separate circuit aftercooler (SCAC)
- Heavy-duty inlet air cleaner
- Heat exchanger or keel cooling
- SCAC and JW shunt tanks with sight glass
- Watercooled exhaust manifold and turbocharger
- Deep sump oil pan
- Oil filler, filter, and dipstick, RH or LH service
- MEUI fuel system
- Duplex fuel filters, RH or LH service
- Engine-mounted fuel cooler
- Fuel transfer and priming pumps
- Hybrid fuel lines
- Electronic fuel/air ratio control
- Electronic diagnostics and fault logging
- Adjustable front support mounting system
- Customer wiring and service tool connector

SPECIFICATIONS

Vee-12, 4-Stroke-Cycle-Diesel

- EPA Tier 3/IMO II compliant
- 32.1 L (1959 cu in) displacement
- 1800-2100 rpm rated engine speed
- 145 mm (5.7 in) bore x 162 mm (6.38 in) stroke
- Turbocharged and aftercooled aspiration
- Electronically governed
- Heat exchanger or keel cooled
- Refill capacity
 - Cooling system: 154 L (40.8 gal) engine and expansion tank
 - Lube oil system: 146 L (38.5 gal)
- 1000-hour oil change interval (A rating)
- 750-hour oil change interval (B rating)
- Caterpillar Diesel Engine Oil 10W30 or 15W40
- SAE No. 0 flywheel and flywheel housing, 136 flywheel teeth
- Counterclockwise rotation from flywheel end

DIMENSIONS

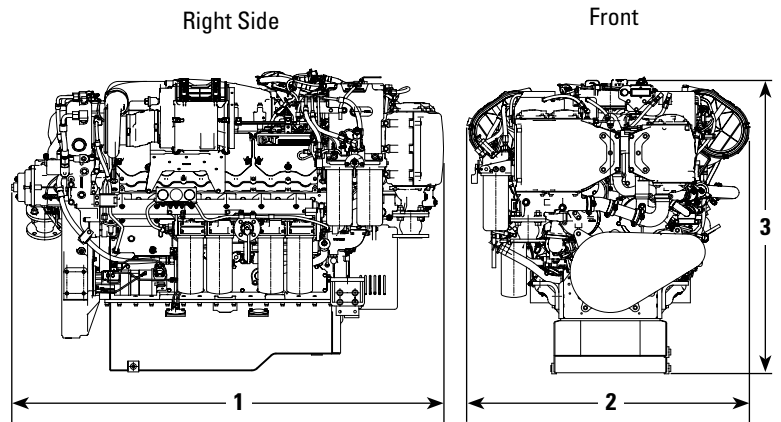

ENGINE DIMENSIONS & WEIGHT

(1) Length (overall)	2284 mm	89.9 in
(2) Width	1528 mm	60.2 in
(3) Height	1584 mm	62.4 in
Weight, Net Dry (keel)	3155 kg	6956 lb
Weight, Net Dry (heat exchanger)	3245 kg	7155 lb

Note: Do not use these dimensions for installation design. See general dimension drawings for detail.

MARINE ENGINE PERFORMANCE

Max Power

A Rating – DM9279-01					B Rating – DM8897-02				
rpm	bhp	g/hr	bkW	g/bkW-hr	rpm	bhp	g/hr	bkW	g/bkW-hr
2100	849	45.4	633	227.9	2100	1199	62.6	894	222.2
1800	849	43.4	633	217.6	1800	1199	62.7	894	222.9
1400	677	32.9	505	206.8	1400	960	47.5	716	210.5
1100	479	23.5	357	208.9	1100	677	34.8	505	218.7
600	110	5.5	82	214.3	600	154	8.0	115	219.4

Prop Demand

A Rating – DM9279-01					B Rating – DM8897-02				
rpm	bhp	g/hr	bkW	g/bkW-hr	rpm	bhp	g/hr	bkW	g/bkW-hr
2100	850	45.5	634	227.9	2100	1200	62.6	895	222.2
1800	535	28.8	399	229.4	1800	756	40.6	564	228.6
1400	252	13.2	188	222.8	1400	356	18.4	265	220.0
1100	122	6.8	91	238.9	1100	172	9.3	129	229.6
600	20	1.6	15	346.9	600	28	2.0	21	302.9

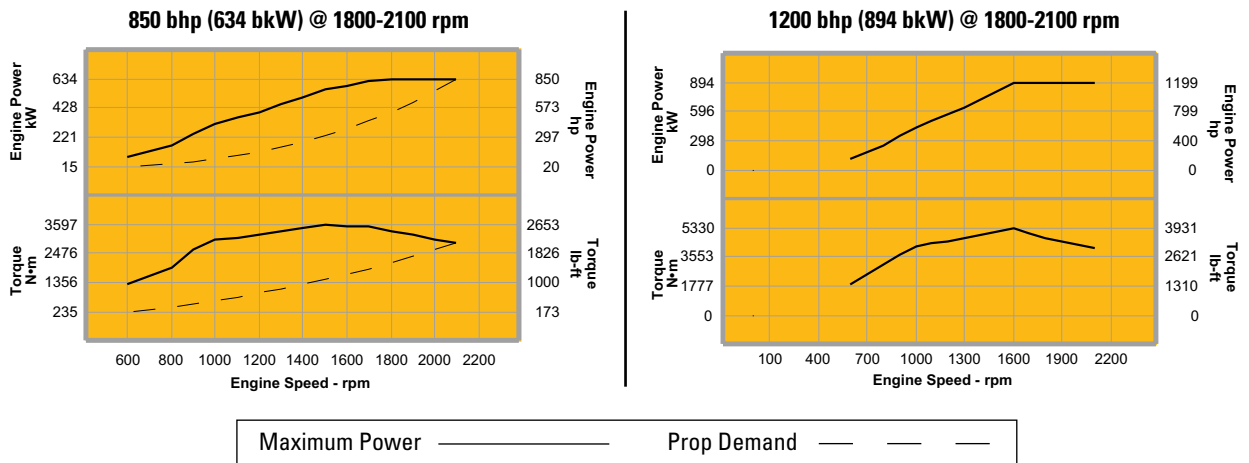

OPTIONAL ATTACHMENTS

- Air inlet adapter
- Battery charger 10 amp
- Charging alternator 24V 105 amp
- Exhaust elbow, dry
- Exhaust flange, flexible fitting, muffler
- Water separator
- Fumes disposal (closed system)
- Duplex oil filters, RH or LH
- Manual sump pump
- Transmission oil cooler
- Starting motors – electric or air
- Dual starting motors (electric and air)
- Jacket water heaters
- Battery sets – 24V 950-1300 CCA
- MECP I control panel
- MECP III control panel with Cat alarm and protection system
- Fuel and oil spray shielding
- OEM wiring harness – 30, 50, 80 foot lengths
- Engine-to-engine wiring harness – 15, 30 foot lengths
- Heavy-duty front support
- Isolator mounts
- Power take-offs

CAT, CATERPILLAR, their respective logos, "Caterpillar Yellow" and the "Power Edge" trade dress, as well as corporate and product identity used herein, are trademarks of Caterpillar and may not be used without permission.