

C18 ACERT™

MARINE PROPULSION ENGINE

803 bhp

599 bkW

2100 rpm



Image shown
may not reflect
actual engine

SPECIFICATIONS

I-6, 4-Stroke-Cycle-Diesel

- EPA Tier 3/IMO II compliant
- 18.0 L (1098 cu in) displacement
- 2100 rpm rated engine speed
- 145 mm (5.7 in) bore x 183 mm (7.2 in) stroke
- Turbocharged and aftercooled aspiration
- Electronically governed
- Heat exchanger or keel cooled
- Refill capacity
 - Cooling system: 45 L (12 gal)
 - Lube oil system: 49 L (13 gal) shallow pan
 - Lube oil system: 68 L (18 gal) deep pan
- 250-hour oil change interval shallow pan
- 500-hour oil change interval deep pan
- Caterpillar Diesel Engine Oil 10W30 or 15W40
- SAE No. 0 flywheel and flywheel housing, 136 flywheel teeth; SAE No. 1 flywheel and housing, 113 teeth
- Counterclockwise rotation from flywheel end



STANDARD ENGINE EQUIPMENT

- Separate circuit aftercooler (SCAC)
- Heavy-duty inlet air filter
- Heat exchanger or keel cooling
- SCAC and JW shunt tanks with sight glass
- Watercooled exhaust manifold and turbocharger
- Center sump oil pan, deep or shallow
- Oil filler, filter, and dipstick, front service
- MEUI fuel system
- Fuel filter, front service
- Fuel transfer and priming pumps
- Hybrid fuel lines
- Electronic fuel/air ratio control
- Electronic diagnostics and fault logging
- Front support adjustable mounting system
- Front damper guard
- Customer wiring and service tool connector

DIMENSIONS

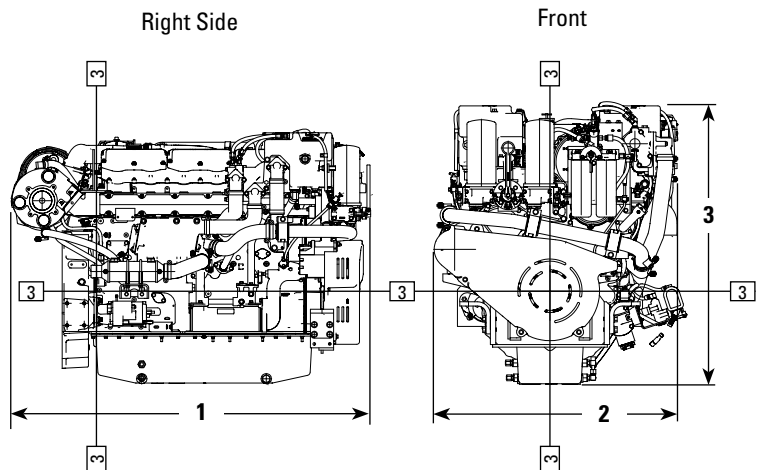

ENGINE DIMENSIONS & WEIGHT

(1) Length	1854 mm	73.0 in
(2) Width	1134 mm	44.6 in
(3) Height	1300 mm	51.2 in
Weight, Net Dry (approx)	*1950 kg	*4,299 lb

Note: Do not use these dimensions for installation design. See general dimension drawings for detail.

*Weight includes electric starting motor and charging alternator.

MARINE ENGINE PERFORMANCE

Max Power D Rating – EM0270-00					Prop Demand D Rating – EM0270-00			
rpm	bhp	g/hr	bkW	g/bkW-hr	bhp	g/hr	bkW	g/bkW-hr
2100	803	42.5	599	225.5	803	42.5	599	225.5
2000	803	42.0	599	222.7	694	36.3	517	222.8
1800	793	39.7	591	213.3	506	26.6	377	224.2
1600	748	36.3	558	206.5	355	18.7	265	223.7
1400	644	31.3	480	206.7	238	10.2	178	183.2

814 mhp (599 bkW) @ 2100 rpm

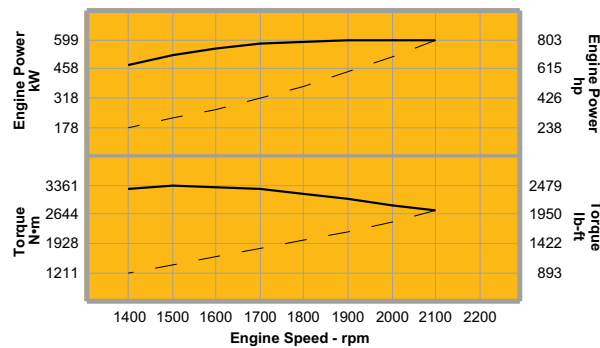

Maximum Power ——— Prop Demand - - - - -

OPTIONAL EQUIPMENT

- Air inlet adapter
- Auxiliary expansion tank flange kit
- Battery charger 10 amp
- Charging alternator 24V 105 amp
- Exhaust elbows, dry or watercooled
- Exhaust flange, flexible fitting, muffler
- Duplex fuel filter – front service
- Fuel cooler, flexible fuel lines
- Primary fuel/water separator
- Duplex oil filter – front service
- Transmission oil cooler
- Manual sump pump
- Vibration isolators
- Starting motors – electric or air
- Jacket water heaters
- Battery sets – 24V 950-1300 CCA
- MECP I control panel
- MECP III control panel with Cat® alarm and protection system
- OEM wiring harness – 30, 50, 80 foot lengths
- Engine-to-engine wiring harness – 15, 30 foot lengths
- Front supports and rear supports
- Power take-offs
- Fumes disposal (closed system)

RATING DEFINITIONS AND CONDITIONS

D Rating (Intermittent Duty)

Typical applications: For vessels operating at rated load and rated speed up to 16% of the time, or 2 hours out of 12, (up to 50% load factor). Typical applications could include but are not limited to

vessels such as offshore patrol boats, customs boats, police boats, some fishing boats, fireboats, or harbor tugs. Typical operation ranges from 1000 to 3000 hours per year.

CAT, CATERPILLAR, their respective logos, ACERT, "Caterpillar Yellow" and the "Power Edge" trade dress, as well as corporate and product identity used herein, are trademarks of Caterpillar and may not be used without permission.