



C18 ACERT MARINE	450 ekW
CLASSIFICATION SOCIETY (MCS)	400 ekW
APPROVABLE GENERATOR SET	350 ekW
	275 ekW
	50 Hz, 1500 rpm



Image may not reflect actual engine

SPECIFICATIONS

I-6, 4-Stroke-Cycle-Diesel

Emissions	IMO/EPA Tier II/ CCNR compliant
Displacement	18.1 L (1106 cu. in.)
Rated Engine Speed	1500 rpm
Bore	145 mm (5.7 in.)
Stroke	183 mm (7.2 in.)
Aspiration	Turbocharged-Aftercooled
Governor	Electronic
Cooling System	Heat Exchanger & Keel Cooled
Weight, Net Dry (approx)	3799-4520 kg (8375-9965 lbs)
Refill Capacities (engine only)	
Cooling System	45.8 L (12.1 gal)
Lube Oil System	71.9 L (19 gal)
Oil Change Interval	500 hr
Rotation (from flywheel end)	Counterclockwise
Flywheel and flywheel housing	SAE No. 0
Flywheel Teeth	136
Max. Exhaust Backpressure	10 kPa (40 in. water)

STANDARD EQUIPMENT

Air Inlet System

Corrosion-resistant sea water aftercooler core; air cleaner/ fumes disposal, jacket water cooled turbocharger, turbocharger inlet OD straight connection

Control System

Note: If an EMCP panel or MCS control panel is not chosen as optional equipment, then start/stop controls must be provided by the customer.

Electronic governing (A4 ECU), programmable low idle, electronic diagnostics and fault logging, fuel/air ratio control

Cooling System

Gear-driven jacket water pump; gear driven, bronze impeller, sea water pump; separate circuit keel cooling or titanium plate heat exchanger (with expansion tank and coolant recovery system).

Exhaust System

Watercooled exhaust manifold and turbocharger; ID round flanged outlet

Flywheels & Flywheel Housings

SAE No. 0 flywheel (136 teeth); SAE No. 0 flywheel housing; SAE standard rotation

Fuel System

Fuel filter (RH or LH service); fuel priming pump; fuel transfer pump; flexible fuel lines

Generator

12-lead reconnectable; three-phase brushless; voltage regulation $\pm 0.5\%$; Class H insulation (generator meets Marine Society temperature rise requirements for Class F insulation) permanent magnet (PMG) excitation; surface-mounted platinum stator and bearing RTDs, space heaters; Cat Digital Voltage Regulator (Cat DVR)

Lube System

Crankcase breather; oil cooler; spin-on oil filters (RH or LH service); deep sump oil pan; oil filler; dipstick (RH or LH service); gear-driven oil pump

Mounting System

254 mm (10 in.) height rails; eight shipped-loose linear vibration isolators for installation below base

Power Take-Offs

Hydraulic pump drive; SAE A; 11 tooth spline; crankshaft pulley (alternator drive)

Protection System

Electronic shutdown (24 volt)

General

Torsional finned vibration damper; lifting eyes; RH or LH service options; literature; variable engine wiring; upper rear-facing customer wiring connector and service tool connection

Factory-designed systems built at Caterpillar ISO 9001:2000 certified facilities.



OPTIONAL EQUIPMENT

Emissions Certifications

CCNR and IMO (ABS or GL), EPA Tier II certifications

Air Inlet System

Heavy duty air cleaner, closed crank case ventilation system-

Charging System

Battery charger - 10A; alternator: 12V (51A or 105A), 24V (35A or 60A)

Control System

EMCP 3 control panel; CMPD

Cooling System

Flange kit

Exhaust System

Dry elbows; water-cooled elbows; flexible fittings; mufflers; flanges; rain caps

Fuel System

Duplex fuel filters; water separators; fuel cooler

Generators & Generator Attachments

Manual voltage control; low voltage connections; loadshare module

Lube System

Sump pumps; oil pan accessories; duplex oil filters

MCS Alarm & Protection System

Includes remote-mountable MCS control panel with 5.7" TFT color screen, all MCS-required alarm & shut-down sensors, full-length drip trays, single-point ship communications (RS-485 modbus RTU), CANOpen, J1939, Ethernet modbus TCP

MCS Alarm & Protection System Options

Remote display (connectable to GPS/GPM) controls up to 8 gensets; 3-phase power monitoring; manual speed control; remote E-stop; programmable I/O and relay modules

Starting System

Air starter; air pressure regulator; air silencer; electric starter (12 or 24V); jacket water heater; battery sets

General

Guards; filter cover kits; tool set; literature; decals; storage preservation; export packing



C18 ACERT MARINE GENERATOR SET

450/400/350/275 EKW

Generator Data – Selected Model

Engine:	C18 ACERT
Fuel:	Diesel
Frequency:	50 Hz
Duty:	PRIME
Generator Frame:	592, 594, 595
Generator Arrang:	344-2710, 344-2712, 344-2714
Excitation Type:	Permanent Magnet
Connection:	SERIES STAR
Genset Rating (kW):	275, 350, 400, 450
Genset Rating (kVA):	343, 437, 500, 562
Pwr. Factor:	0.8
Application:	MAR
Line-Neutral Voltage:	110-115/220-230-240
Line-Line Voltage:	190-200/380-400-415
Rated Current:	663-2368
Status:	Available for order
S/N prefix:	GBM (pkg)
Engineering Model:	GS388 (pkg)

Generator – Weights

344-2710	
Generator Wt	1549 kg (3415 lbs)
Rotor Weight	458 kg (1010 lbs)
Stator Weight	1091kg (2405 lbs)
344-2712	
Generator Wt	1772 kg (3907 lbs)
Rotor Weight	566 kg (1248 lbs)
Stator Weight	1206 kg (2659 lbs)
344-2714	
Generator Wt	1860 kg (4100 lbs)
Rotor Weight	670 kg (1476 lbs)
Stator Weight	1190 kg (2624 lbs)

*Note: Rotor Balance = 0.0508 mm deflection PTP
Overspeed capacity = 180% of synchronous speed

Voltage Regulation

Voltage level adjustment: +/-	5.0%
Voltage regulation, steady state: +/-	0.5%
Voltage regulation w/ 3% speed change: +/-	0.5%
Waveform deviation line- line, no load: less than	3.0%
Telephone influence factor: less than	50

Generator – Center of Gravity

Dimension X	344-2710	-662.4 mm (-26.1 in)
	344-2712	-758.6 mm (-29.7 in)
	344-2714	-744.0 mm (-29.3 in)

Dimension Y 0.0 mm (0.0 in)

Dimension Z 0.0 mm (0.0 in)

- “X” is measured from driven end of generator and parallel to rotor. Towards engine fan is positive.
- “Y” is measured vertically from rotor centerline. Up is positive.
- “Z” is measured to left and right of rotor Center line. To the right is positive.

Generator Specifications

Frame:	592, 594, 595
Type:	SR4B
No. Of Bearings:	1
Winding Type	RND Wound
Flywheel:	18
Housing:	SAE No. 0
Phases:	3
No. Of Leads:	12
Poles:	4
Wires per Lead:	2
Sync Speed:	1500
Generator Pitch:	0.6667 (592, 594) 0.7333 (595)
Insulation:	Class H
IP Rating:	Drip Proof IP 23*
Alignment:	Pilot Shaft
Overspeed Capability:	180
Paralleling/ Droop:	Standard

* Package is compatible with Fixed Water Based Local Application Fire Fighting System (FWBLAFFS)

Generator Excitation

	No Load	Full Ld Series	Full Ld Parallel
Excitation current in amps:			
344-2710	1.98	6.89	6.71
344-2712	2.1	6.72	6.67
344-2714	1.94	6.8	6.71



C18 ACERT MARINE GENERATOR SET

450/400/350/275 EKW

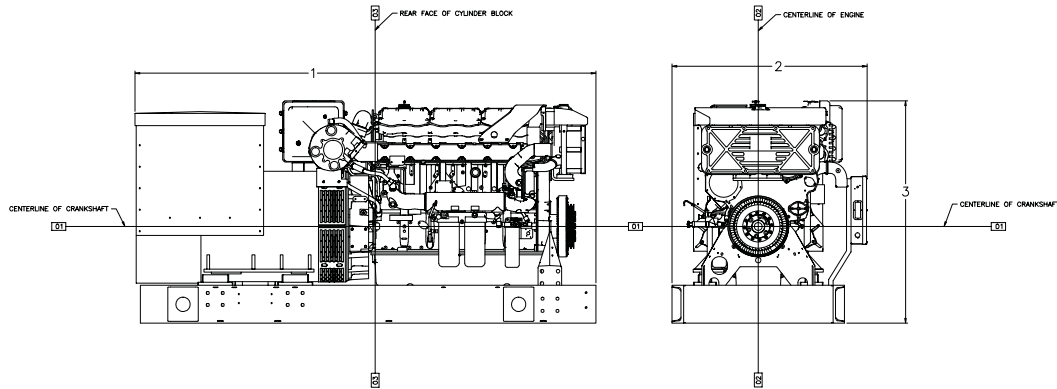

DIMENSIONS

Package Dimensions (Heat Exchanger Cooled)		
(1) Length	3075.5 mm	121.08 in
(2) Width	1300.8 mm	51.21 in
(3) Height	1484.5 mm	58.44 in
Weight, Net Dry - Pkg (approx)	3587-4391 kg	7890-9660 lb

Note: Do not use for installation design.

GENERATOR DATA

50 Hz

Power	Generator Arrangement	Leads	Pitch	Excite
275 ekW	342-2710	12	0.6667	Permanent Magnet
350 ekW	342-2710	12	0.6667	Permanent Magnet
400 ekW	342-2712	12	0.6667	Permanent Magnet
450 ekW	342-2714	12	0.7333	Permanent Magnet

PERFORMANCE DATA

50 Hz @ 1500 rpm			
% load	ekW	Lph	gph
DM9663			
100	275	75.2	19.9
75	206	57.3	15.1
50	138	40.1	10.6
DM9664			
100	350	95.4	25.2
75	263	72.0	19.0
50	175	49.5	13.1
DM9665			
100	400	108.6	28.7
75	300	82.7	21.8
50	200	56.0	14.8
DM9666			
100	450	122.5	32.3
75	338	92	24.3
50	225	62.5	16.5

RATING CONDITIONS

Power at declared engine speed is in accordance with ISO3046-1:2002E. Caterpillar maintains ISO9001:1994/QS-9000 approved engine test facilities to assure accurate calibration of test equipment. Electronically controlled engines are set at the factory at the advertised power corrected to standard ambient conditions. The published fuel consumption rates are in accordance with ISO3046-1:2002E.

Fuel rates are based on fuel oil of 35° API [16°C (60°F)] gravity having an LHV of 42 780 kJ/kg (18,390 Btu/lb) when used at 29°C (85°F) and weighing 838.9 g/L (7.001 lb/U.S. gal). Additional ratings may be available for specific customer requirements. Consult your Caterpillar representative for additional information.

Performance data is calculated in accordance with tolerances and conditions stated in this specification sheet and is only intended for purposes of comparison with other manufacturers' engines. Actual engine performance may vary according to the particular application of the engine and operating conditions beyond Caterpillar's control.

Power produced at the flywheel will be within standard tolerances up to 49°C (120°F) combustion air temperature measured at the air cleaner inlet, and fuel temperature up to 52°C (125°F) measured at the fuel filter base. Power rated in accordance with NMMA procedure as crankshaft power. Reduce crankshaft power by 3% for propeller shaft power.

CAT, CATERPILLAR, their respective logos, ACERT, "Caterpillar Yellow" the "Power Edge" trade dress as well as corporate and product identity used herein, are trademarks of Caterpillar and may not be used without permission.