



# C4.4 ACERT™ Industrial Engine

Tier 4 Final/Stage IV Technology  
70-129.4 bkW/93.9-173.5 bhp @ 2200 rpm

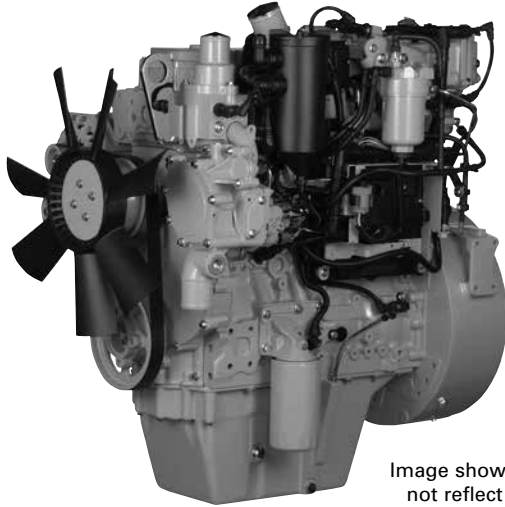

Image shown may not reflect actual engine configuration

## CAT® ENGINE SPECIFICATIONS

### I-4, 4-Stroke-Cycle Diesel

Bore	105 mm (4.13 in)
Stroke	127 mm (5.00 in)
Displacement	4.4 L (268.5 in <sup>3</sup> )
Aspiration	Turbocharged-Aftercooled (TA) or Series Turbocharged-Aftercooled (TTA)
Compression Ratio	16.5:1
Combustion System	Direct Injection
Rotation (from flywheel end)	Counterclockwise
Capacity for Liquids	
Cooling System	10.8 L (11.4 U.S. qts)
Lube System (refill) sump dependent	5.2-13.5 L (5.5-14.27 U.S. qts)
Engine Weight, Net Dry (approximate)	
TA	400 kg (926 lbs)
TTA	420 kg (881.8 lbs)

## FEATURES

### Emissions

Designed to meet U.S. EPA Tier 4 Final, EU Stage IV emission standards.

### Reliable, Quiet, and Durable Power

World-class manufacturing capability and processes coupled with proven core engine designs assure reliability, quiet operation, and many hours of productive life.

### High Performance

Series turbocharging with smart wastegate available on specific ratings for fast response, high power, and increased torque.

### Fuel Efficiency

Fuel consumption optimized to match operating cycles of a wide range of equipment and applications.

### Fuel & Oil

Tier 4 Final/Stage IV engines require Ultra Low Sulfur Diesel (ULSD) fuel containing a maximum of 15 ppm sulfur, and new oil formulations to support the new technology. Cat® engines are designed to accommodate B20 biofuel. Your Cat dealer can provide more information regarding fuel and oil.

### Broad Application Range

Industry leading range of factory configurable ratings and options for agricultural, materials-handling, construction, mining, aircraft ground support, and other industrial applications.

### Package Size

Ideal for equipment with narrow engine compartments. Multiple installation options minimize total package size.

### Low-Cost Maintenance

Worldwide service delivers ease of maintenance and simplifies the servicing routine. Hydraulic tappets, multi-vee belts, "no ash service" aftertreatment, and 500-hour oil change intervals enable low-cost maintenance. Many service items have a choice of location on either side of the engine to enable choice of service access. The S•O•S<sup>SM</sup> program is available from your Cat dealer to determine oil change intervals and provide optimal performance.

### Quality

Every Cat engine is manufactured to stringent quality standards in order to assure customer satisfaction.

### World-class Product Support Offered Through Global Cat Dealer Network

- Scheduled maintenance, including S•O•S sample
- Customer Support Agreements (CSA)
- Caterpillar Extended Service Coverage (ESC)
- Superior dealer service network
- Extended dealer service network through the Cat Industrial Service Distributor (ISD) program

**Web Site: For additional information on all your power requirements, visit [www.cat-industrial.com](http://www.cat-industrial.com).**

**STANDARD ENGINE EQUIPMENT**

**Air Inlet**

Standard air cleaners.

**Control System**

Full electronic control system, all connectors and wiring looms waterproof and designed to withstand harsh off-highway environments, flexible and configurable software features and well supported SAE J1939 CAN bus enables highly integrated machines.

**Cooling System**

Top tank temperature 108°C (226°F) as standard to minimize cooling pack size, 50:50 water glycol mix, detailed guidance on cooling system design and validation available to ensure machine reliability.

**Exhaust System**

Optimized DOC/SCR system supplied with a range of inlet and outlet options. DOC/DPF/SCR option available for use on higher powers. Both systems are service-free and, when in use, invisible to the operator.

**Flywheels and Flywheel Housing**

Wide choice of drivetrain interfaces, including but not limited to SAE2 and SAE3 configurations.

**Fuel System**

Electronic high pressure common rail, ACERT™ Technology, innovative filter design to ensure maximum protection of the engine.

**Lube System**

Choice of sumps for different applications.

**Power Take Off**

SAE A or SAE B flanges on left-hand side, additional SAE A flange available on LHS, engine power can also be taken from the front of the engine on some applications, factory fitted compressors are also available.

**General**

Available with or without a balancer.

**DIMENSIONS**

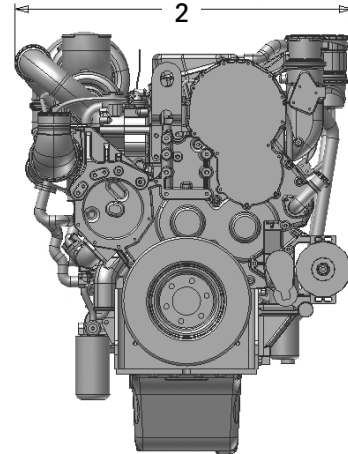
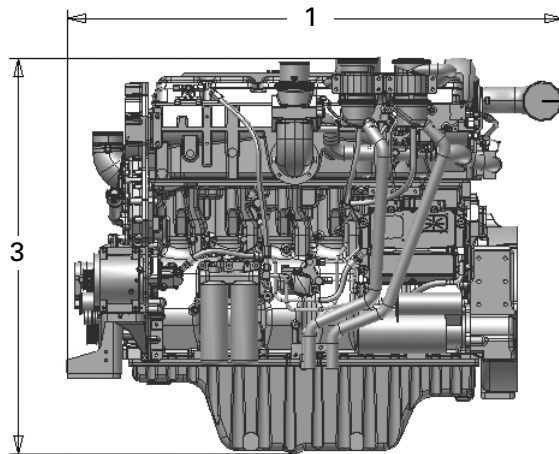

(1) Length

TA, TTA: 845.1 mm (33.3 in)

(2) Width

TA: 772.4 mm (30.4 in)  
TTA: 741.6 mm (29.1 in)

(3) Height

TA: 848.2 mm (33.4 in)  
TTA: 867.6 mm (34.1 in)

**Note:** Final dimensions dependent on selected options



# C4.4 ACERT™ Industrial Engine

Tier 4 Final/Stage IV Technology  
70-129.4 bkW/93.9-173.5 bhp @ 2200 rpm

## PERFORMANCE DATA — PRELIMINARY

Turbocharged-Aftercooled — 2200 rpm

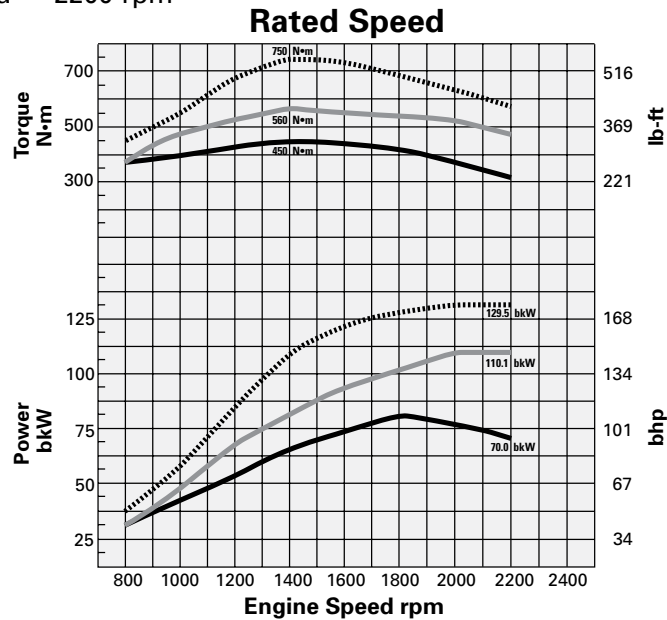

### Speed Range

Rating	Aspiration	Rated Speed rpm	Rated Power bkW	Rated Power bhp	Speed rpm	Peak Torque N·m	Peak Torque lb-ft
C*	TA	2200	70.0	93.9	1400	450	331.9
C	TA	2200	74.4	99.8	1400	450	331.9
C	TA	2200	82.0	109.9	1400	450	331.9
C	TA	2200	85.9	115.2	1400	500	368.8
C	TA	2200	91.0	122.0	1400	500	368.8
C	TA	2200	92.6	124.2	1400	530	390.9
C	TA	2200	97.9	131.3	1400	530	390.9
C	TA	2200	102.1	136.9	1400	560	413.1
C	TA	2200	106.0	142.1	1400	560	413.1
C*	TA	2200	110.1	147.6	1400	560	413.1
C	TTA	2200	105.0	140.8	1400	630	464.7
C	TTA	2200	112.0	150.2	1400	650	479.4
C	TTA	2200	117.0	156.9	1400	683	503.8
C*	TTA	2200	129.4	173.5	1400	750	553.2

B Rating performance data to be added when available.

## RATING DEFINITIONS AND CONDITIONS

**IND-C (Intermittent)** is the horsepower and speed capability of the engine where maximum power and/or speed are cyclic (time at full load not to exceed 50%).

Additional ratings are available for specific customer requirements. Consult your Cat dealer.

**Rating Conditions** are based on ISO/TR14396, inlet air standard conditions with a total barometric pressure of 100 kPa (29.5 in Hg), with a vapor pressure of 1 kPa (.295 in Hg), and 25°C (77°F). Performance is measured using fuel to EPA specifications in 40 CFR Part 1065 and EU specifications in Directive 97/68/EC with a density of 0.845-0.850 kg/L @ 15°C (59°F) and fuel inlet temperature 40°C (104°F).



# C4.4 ACERT™ Industrial Engine

Tier 4 Final/Stage IV Technology  
70-129.4 kW/93.9-173.5 bhp @ 2200 rpm

## AFTERTREATMENT CONFIGURATION

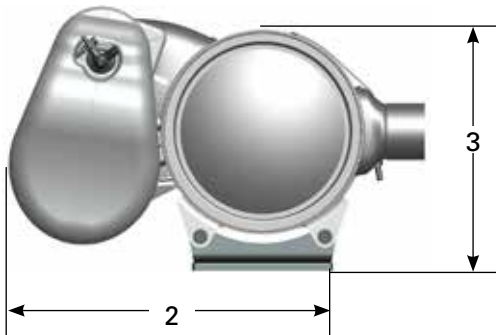

Less than or equal to 92.6 kW  
(124.2 bhp)

### DOC/SCR CONFIGURATION

#### Approximate Size and Weight

- (1) Length — 647 mm (25.5 in)
- (2) Width — 538 mm (21.18 in)
- (3) Height — 335 mm (13.19 in)
- Weight — 40 kg (88 lb)

Greater than 92.6 kW  
(124.2 bhp)

### DOC/SCR CONFIGURATION

#### Approximate Size and Weight

- (1) Length — 675 mm (25.6 in)
- (2) Width — 565 mm (22.2 in)
- (3) Height — 355 mm (13.97 in)
- Weight — 45 kg (99 lb)

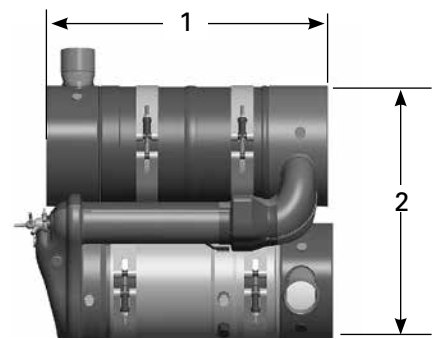
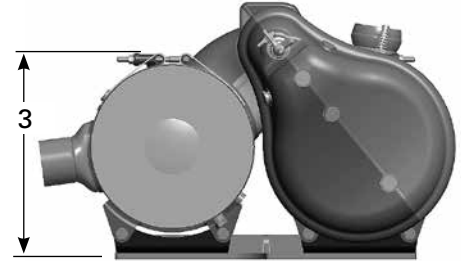

### DOC/DPF/SCR CONFIGURATION (TTA ONLY)

#### Approximate Size and Weight

- (1) Length — 722 mm (28.4 in)
- (2) Width — 695 mm (27.4 in)
- (3) Height — 430 mm (16.9 in)
- Weight — 80 kg (176.4 lb)

## AFTERTREATMENT FEATURES

**Regeneration:** The DOC/SCR modular design offers a simple, compact package while providing high levels of performance. A DOC/DPF/SCR option is available for higher power machines.

While in use, both DOC/SCR and DOC/DPF/SCR systems offer transparent operation to the user.

**Mounting:** Extensive range of inlets and outlets, as well as remote and on-engine installations, provide flexibility for many installations.

**Service:** Both DOC/SCR and DOC/DPF/SCR systems are service-free for the emissions life of the engine.

Available in 12V or 24V systems

## STANDARD EMISSIONS CONTROL EQUIPMENT

**DOC:** Diesel Oxidation Catalyst

**DPF:** Diesel Particulate Filter

**SCR:** Selective Catalytic Reduction

3" flex pipe connection kit with straight, 45°, and 90° options for flexibility

A range of SCR system components, including pump, tanks, and lines

Materials and specifications are subject to change without notice. The International System of Units (SI) is used in this publication. CAT, CATERPILLAR, their respective logos, ACERT, S•O•S, "Caterpillar Yellow" and the "Power Edge" trade dress, as well as corporate and product identity used herein, are trademarks of Caterpillar and may not be used without permission.