



C9.3 ACERT™ Industrial Power Unit

Tier 4 Interim/Stage IIIB
224-261 kW (300-350 bhp) @ 1800-2200 rpm

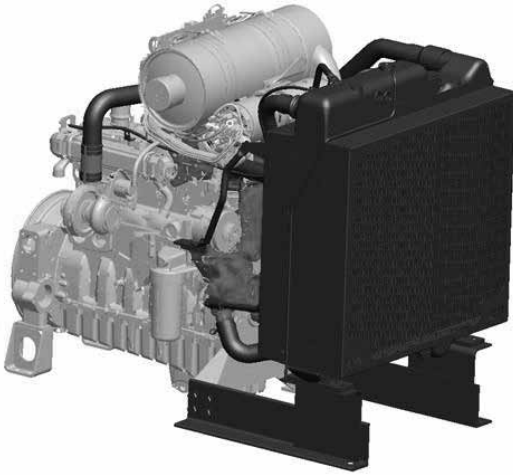

Image shown may not reflect actual power unit configuration

CAT® ENGINE SPECIFICATIONS

I-6, 4-Stroke-Cycle Diesel

Bore	115 mm (4.53 in)
Stroke	149 mm (5.87 in)
Displacement	9.3 L (567.5 in ³)
Aspiration	Turbocharged-Aftercooled
Compression Ratio	17.0:1
Combustion System	Direct Injection
Rotation (from flywheel end) ...	Counterclockwise
Capacity for Liquids	
Cooling System (includes engine, lines, radiator, shunt tank)	54 L (57.0 U.S. qts)
Lube System (refill)*	30 L (31.7 U.S. qts)
Package Weight, Net Dry	
(approximate)	1839 kg (4055 lbs)

*Capable of up to 500-hour oil change interval, dependent on oil pan size, rating, application, operating conditions, and maintenance practices.

FEATURES

Emissions

Designed to meet 2011 EPA (U.S.) Tier 4 Interim and EU Stage IIIB emissions requirements. Also expected to meet Japanese MLIT emissions requirements once available.

Reliable, Quiet, and Durable Power

World-class manufacturing capability and processes coupled with proven core engine designs assure reliability, quiet operation, and many hours of productive life.

High Performance

Simple and efficient turbocharger with balance valve provides optimal air management and improved fuel efficiency.

Fuel Efficiency

Fuel consumption optimized to match operating cycles of a wide range of equipment and applications.

Fuel & Oil

Tier 4 Interim/Stage IIIB engines require Ultra Low Sulfur Diesel (ULSD) fuel containing a maximum of 15 ppm sulfur, and new oil formulations to support the new technology. Cat® engines are designed to accommodate B20 biofuel. Your Cat dealer can provide more information regarding fuel and oil.

Broad Application Range

Industry leading range of factory configurable ratings and options for agricultural, materials-handling, construction, mining, forestry, waste, and other industrial applications.

Package

Exceptional power density enables standardization across numerous applications. Available factory-installed configurations: full package, including radiator and Clean Emissions Module (CEM); package with CEM, but no radiator; and package with radiator, but no CEM.

Low-Cost Maintenance

Worldwide service delivers ease of maintenance and simplifies the servicing routine. Minimum 5000-hour diesel particulate filter ash service interval enables low-cost maintenance. Capable of optimal oil change intervals of up to 500 hours, depending on rating, application, operating conditions, and maintenance practices. The S•O•SSM program is available from your Cat dealer to determine oil change intervals and provide optimal performance.

Quality

Every Cat engine is manufactured to stringent standards in order to assure customer satisfaction.

World-class Product Support Offered Through Global Cat Dealer Network

- Scheduled maintenance, including S•O•SSM sample
- Customer Support Agreements (CSA)
- Cat Extended Service Coverage (ESC)
- Superior dealer service network
- Extended dealer service network through the Cat Industrial Service Distributor (ISD) program

Web Site: For additional information on all your power requirements, visit www.cat-industrial.com.



C9.3 ACERT™ Industrial Power Unit

Tier 4 Interim/Stage IIIB
224-261 bkW (300-350 bhp) @ 1800-2200 rpm

STANDARD ENGINE EQUIPMENT

Air Inlet System

Turbocharged Air-to-Air Aftercooled

Control System

Electronic control system, over-foam wiring harness, automatic altitude compensation, power compensated for fuel temperature, configurable software features, engine monitoring system SAE J1939 broadcast and control, integrated Electronic Control Unit (ECU)

Cooling System

Vertical outlet thermostat housing, centrifugal water pump, guidance on cooling system design available to ensure machine reliability

Exhaust System

CEM that includes Diesel Particulate Catalyst (DPF), Diesel Oxidation Catalyst (DOC), and Cat Regeneration System

Flywheels and Flywheel Housing

SAE No. 1 and SAE No. 2 flywheel housing, dual rear PTO configuration

Fuel System

High pressure common rail, primary fuel filter, secondary fuel filters, fuel transfer pump, electronic fuel priming

Lube System

Open crankcase ventilation system, oil cooler, oil filler, oil filter, oil dipstick, oil pump (gear driven), choice of sumps (front, rear, and center)

Power Take Off

SAE A, SAE B, and SAE C drives available

General

Paint: Cat yellow, vibration damper, lifting eyes

DIMENSIONS

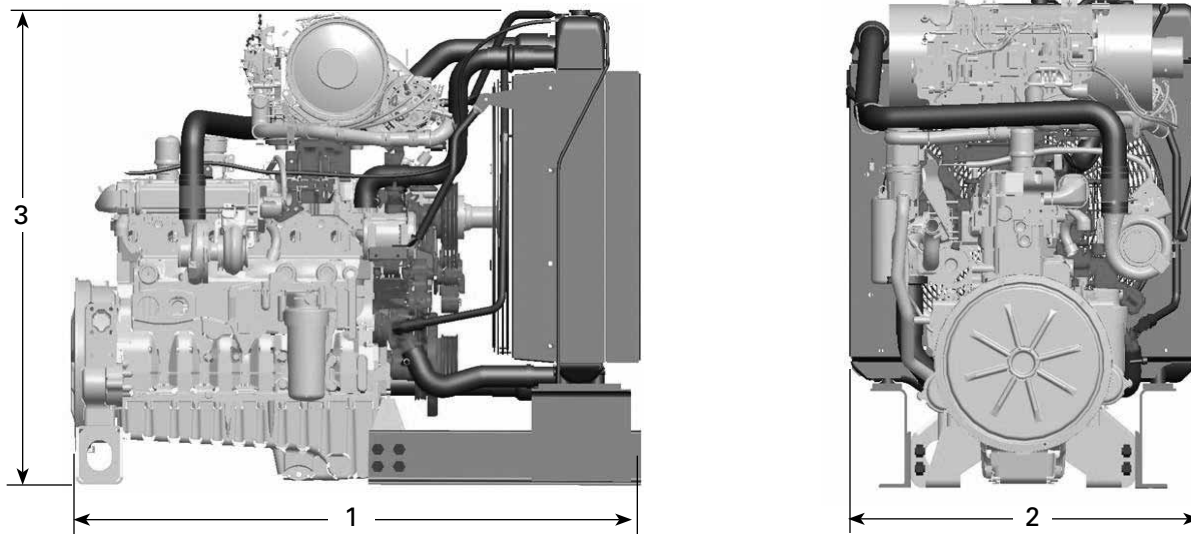

(1) Length — 1845 mm (72.6 in) (2) Width — 1118 mm (44.0 in) (3) Height — 1554 mm (61.2 in)

Note: Final dimensions dependent on selected options



C9.3 ACERT™ Industrial Power Unit

Tier 4 Interim/Stage IIIB
224-261 kW (300-350 bhp) @ 1800-2200 rpm

PERFORMANCE DATA — PRELIMINARY

Turbocharged-Aftercooled — 1800-2200 rpm

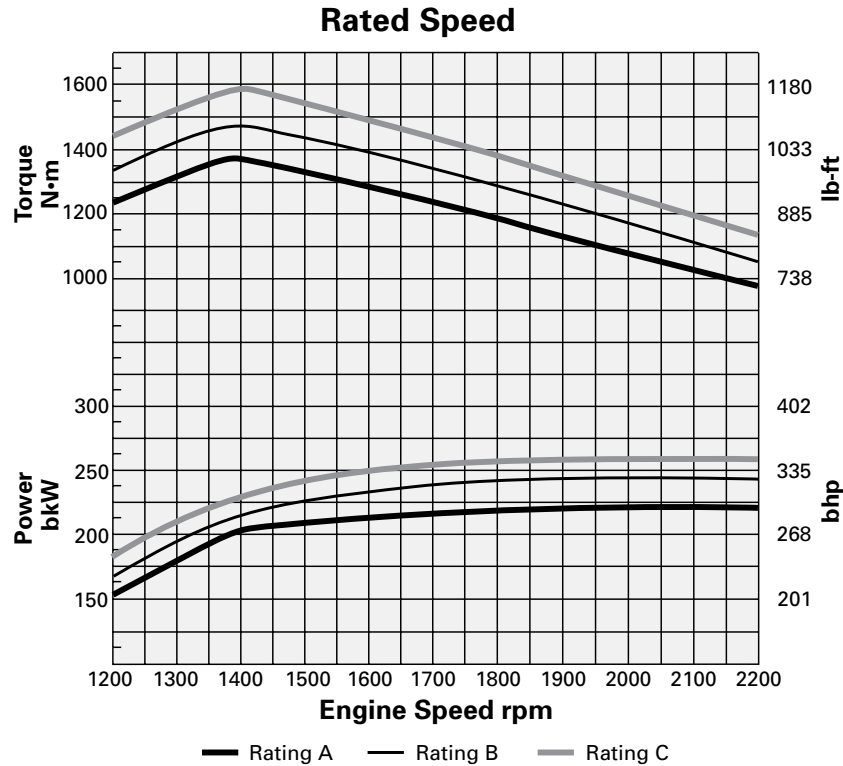

Speed Range

Rating	Speed rpm	Peak Power kW	Peak Power bhp	Speed rpm	Peak Torque N·m	Peak Torque lb-ft
A	2200	224	300	1400	1369	1010
B	2200	242	325	1400	1483	1094
C	2200	261	350	1400	1597	1178

RATING DEFINITIONS AND CONDITIONS

IND-A (Continuous) for heavy duty service where the engine is operated at maximum power and speed up to 100% of the time without interruption or load cycling.

IND-B for service where power and/or speed are cyclic (time at full load not to exceed 80%).

IND-C (Intermittent) is the horsepower and speed capability of the engine where maximum power and/or speed are cyclic (time at full load not to exceed 50%).

Additional ratings are available for specific customer requirements. Consult your Cat dealer.

Rating Conditions are based on SAE J1995, inlet air standard conditions of 99 kPa (29.31 in Hg) dry barometer and 25°C (77°F) temperature. Performance measured using a standard fuel with fuel gravity of 35° API having a lower heating value of 42 780 kJ/kg (18,390 btu/lb) when used at 29°C (84.2°F) with a density of 838.9 g/L.



C9.3 ACERT™ Industrial Power Unit

Tier 4 Interim/Stage IIIB
224-261 kW (300-350 bhp) @ 1800-2200 rpm

AFTERTREATMENT CONFIGURATION

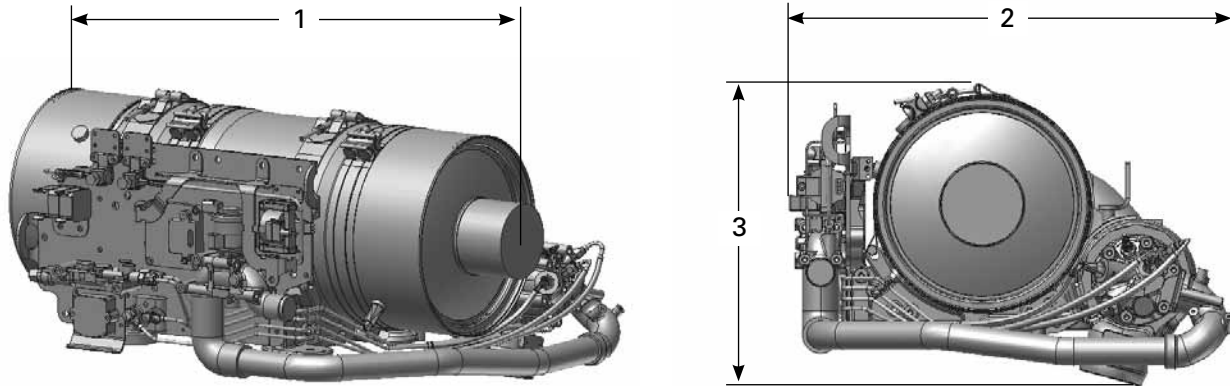

Images shown may not reflect actual aftertreatment.

304.8 mm (12 in) DIAMETER BASE CONFIGURATION SHOWN

Approximate Size and Weight

- (1) Length — 925.89 mm (36.45 in)
 - (2) Width — 714.40 mm (28.12 in)
 - (3) Height — 392.21 mm (15.44 in)
- Weight — 130 kg (287 lbs)

CEM Options

Base configuration includes DPF, DOC, and supporting structure

Standard configuration is also available, which includes DPF, DOC, muffler, and supporting structure. Contact your Cat dealer for additional information.

AFTERTREATMENT FEATURES

Regeneration: Cat Regeneration System maximizes fuel efficiency during regeneration

Flexibility: Flexible regen options maximize uptime

Service: Minimum 5000-hour diesel particulate filter ash service interval

Available in 12V or 24V systems

STANDARD EMISSIONS CONTROL EQUIPMENT

Cat Regeneration System

CEM: Clean Emissions Module

DOC: Diesel Oxidation Catalyst

DPF: Diesel Particulate Filter

NRS: NOx Reduction System

Materials and specifications are subject to change without notice. The International System of Units (SI) is used in this publication. CAT, CATERPILLAR, their respective logos, ACERT, S•O•S, "Caterpillar Yellow" and the "Power Edge" trade dress, as well as corporate and product identity used herein, are trademarks of Caterpillar and may not be used without permission.