

CAT® PUMPS & MOTORS FOR MINING

PROVEN PERFORMANCE

TAKE A CLOSER LOOK AT HOW CAT® HYDRAULIC PUMPS
AND MOTORS BRING VALUE TO YOUR MINE SITE.

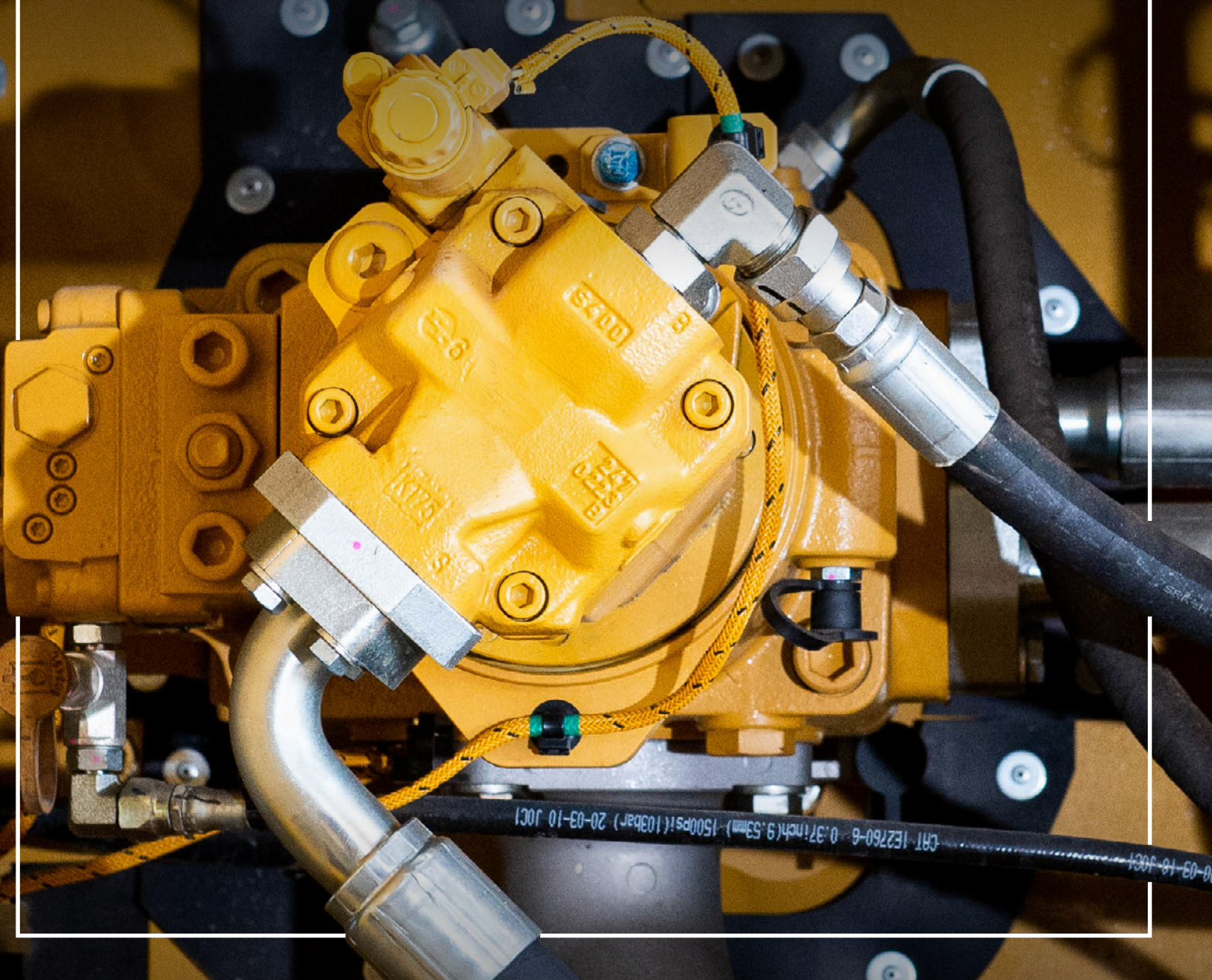

DESIGNED WITH YOUR DEMANDS IN MIND

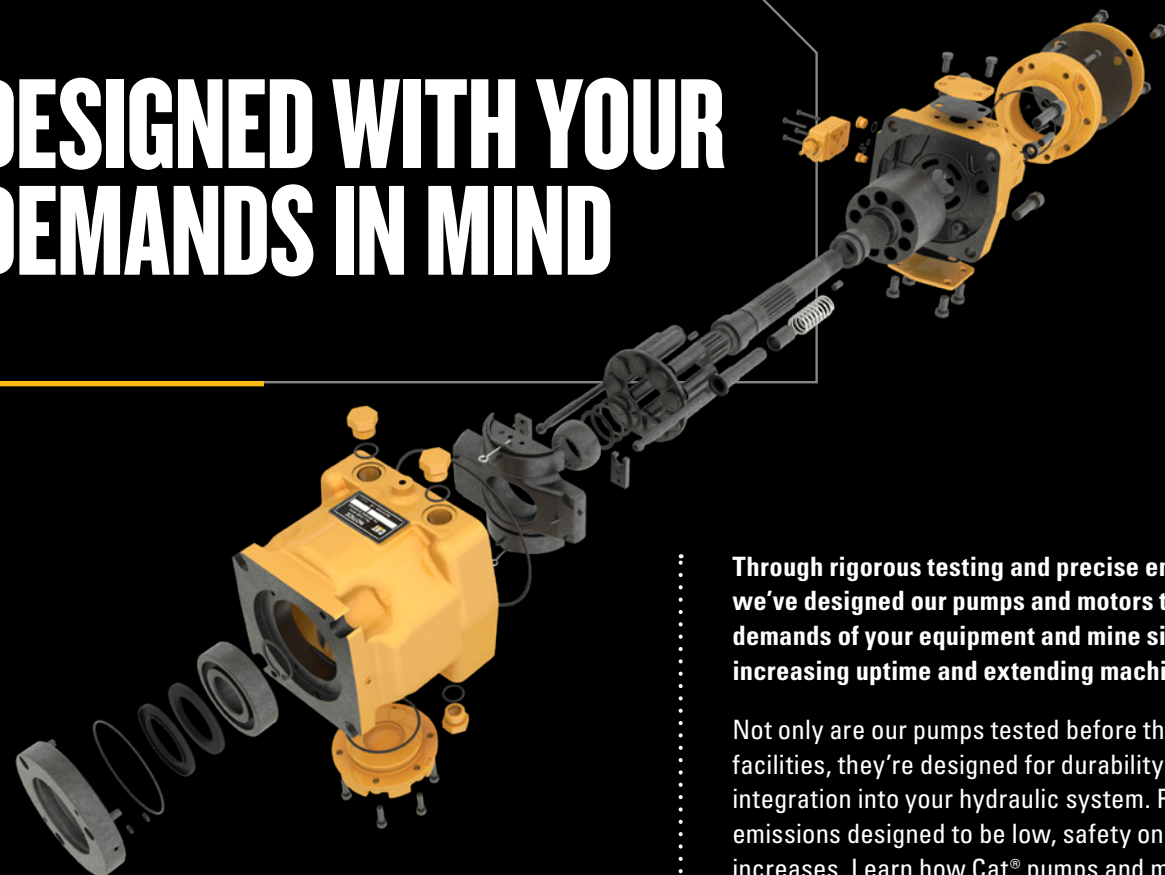

Through rigorous testing and precise engineering, we've designed our pumps and motors to meet the demands of your equipment and mine site, all while increasing uptime and extending machine life.

Not only are our pumps tested before they leave our facilities, they're designed for durability and easy integration into your hydraulic system. Plus, with noise emissions designed to be low, safety on the jobsite increases. Learn how Cat® pumps and motors can add value to your operation.



THE VALUE OF CAT PUMPS & MOTORS

RELIABILITY AND PERFORMANCE

Custom splines, control pistons, and lubrication systems enable Cat pumps to have a longer life. This means increased machine availability and reduced downtime for your operation. To meet the demands of any jobsite, Cat hydraulic pumps are designed with high-end materials that decrease the possibility for a need to repair.

LONG-TERM SUPPORT

In the event of a challenge, Cat parts are covered by a Caterpillar Limited Warranty.¹ The Cat dealer network is also there to support you with maintenance and repair, offering a variety of options to suit the needs of your mine site.

REDUCED LABOR AND DOWNTIME

Cat pumps and motors are designed for Cat machines and meet specifications right out of their boxes for reduced downtime and labor. Additionally, Cat pumps and motors are engineered to fit seamlessly into your hydraulic systems.

¹Warranty can vary by model and application; limitations apply. For complete details about the applicable Caterpillar Limited Warranty, contact an authorized Cat dealer.

DESIGNED FOR UPTIME

Here's a closer look at what sets Cat pumps and motors apart.

HIGHER-PERFORMING SHAFT SEALS

Accommodate rigorous pressure, withstand temperature ranging from arctic to desert, and meet speed demands.

UNIQUELY-DESIGNED, ROBUST SEALS

Offer durable designs that protect against case pressures.

INNOVATIVE SEALS AND GASKETS

Withstand extreme hydraulic system pressures and temperatures, reduce leakage, and increase reliability.

SOLENOID CONTROL VALVE

Includes features in the stroking mechanism that improve component performance and response, defending against contamination.

STURDY BEARINGS AND BUSHINGS

Enable higher power density for peak, on-demand hydraulic system performance, and increased service life.

BETTER FLUSHING AND LUBRICATION FLOWS

Yield longer component lives.

HIGHER-GRADE SWIVEL LINKAGE AND SWASH PLATE MATERIAL

Exceed typical heat-treat standards, enabling extended component life.

HIGH-SPEED ROTATING GROUPS

Provide better fill capability which prevents cavitation erosion. Plus, the inhibition of debris generation improves system reliability and extends pump life.

OPTIMIZED PORT PLATE TIMING

Improves the flow and pressure dynamics of hydraulic fluid.



PUMPS FOR EVERY APPLICATION

GEAR PUMPS

- + Simple, rugged, least expensive
- + Higher resistance to contamination
- + Well suited to lower-pressure, higher-flow applications
- + More durable and reliable two-piece cast iron helps prevent shaft seal leaks
- + Smaller units use valves to improve hydraulic system integration
- + Available in fixed-displacement option

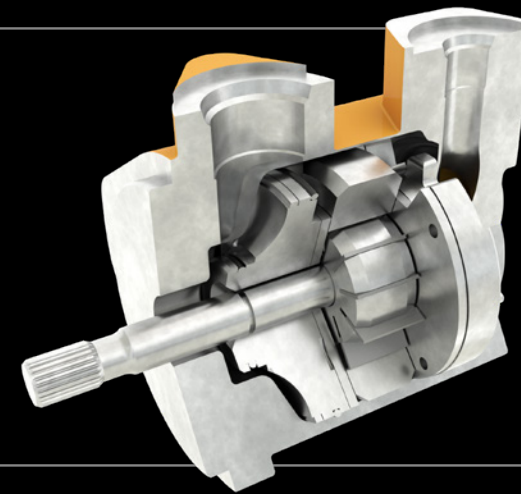
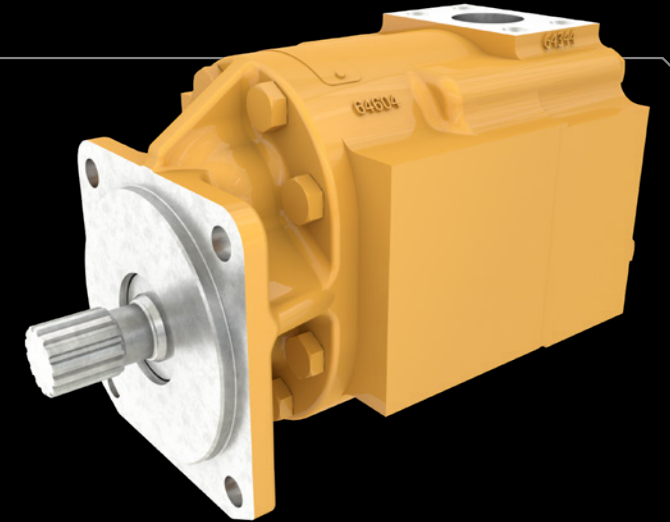

VANE PUMPS

- + Simple and inexpensive
- + Increased pressure limits
- + Feature cam-rings designed for tougher duty cycles
- + Pressure plates and seals designed for long-term use
- + Used in less-demanding applications

PISTON PUMPS

- + More efficient
- + Longer service life
- + Higher pressure capabilities
- + Customized based on productivity in specific applications
- + Pumps and motors are available in variable and fixed displacement configurations

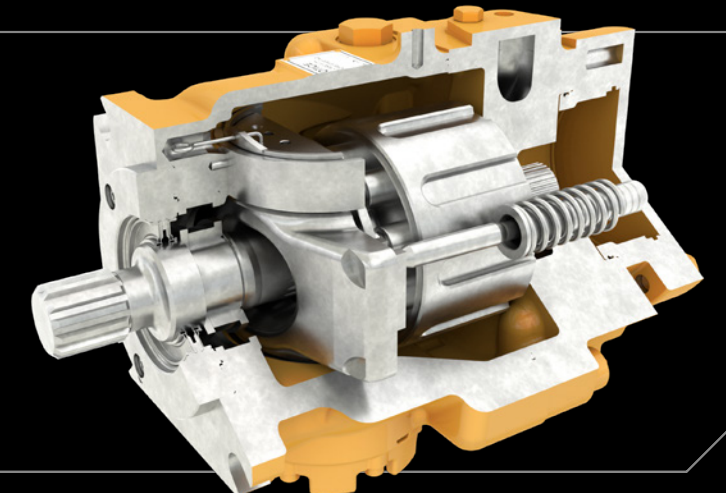

REPAIRS AND REPLACEMENTS FOR PUMPS AND MOTORS

For any repairs or replacements needed, your Cat dealer has you covered. You can expect a wide range of basic and economical services that'll fit your budget and time constraints. Here are the five levels of maintenance that you can choose from:

LEVEL 1

RESEAL

- + Lowest-cost option
- + Restore undamaged components
- + Do-it-yourself kits or work with your dealer

LEVEL 2

REPAIR

- + Ideal for lightly damaged pumps and motors
- + Retains reusable parts for cost

LEVEL 3

REBUILD

- + For more severely damaged pumps and motors
- + Retains reusable parts for cost
- + Restores components to like new condition

LEVEL 4

CAT REMAN

- + Like new performance for fraction-of-new price with core return
- + Same-as-new Caterpillar Limited Warranty¹
- + Off-the-shelf availability
- + Less greenhouse gases processed and less process energy used²

LEVEL 5

NEW

- + Genuine Cat parts³

¹Warranty can vary by model and application; limitations apply. For complete details about the applicable Caterpillar Limited Warranty, contact an authorized Cat dealer.

²Any Cat Reman sustainability statements represent U.S. environmental impacts comparing "gate-to-gate" remanufacturing and manufacturing processes for engines and components. Based on 2018 external study of Cat engines, alternators and turbochargers. Does not include impacts elsewhere in our value chain.

³Not all Cat dealers provide all repair levels. Please consult your local Cat dealer for more information.



CUSTOMER VALUE AGREEMENTS (CVAs) FOR MINING

Tailored by you and your dealer, CVA solutions can range from delivered maintenance kits to flexible payment options and tailored component cost-per-hour guarantees.

HASSLE-FREE OWNERSHIP

You only pay for the hours you use and have access to planned replacement and repair scheduling.

HASSLE-FREE MAINTENANCE

You'll have maintenance options ranging from delivered wear parts for do-it-yourself maintenance to dealer labor.

SECURITY OF EXPERT DEALER SUPPORT

Your CVA includes selection consultation, along with dealer management expertise, and specialized tools.

PEACE OF MIND FROM EQUIPMENT HEALTH MANAGEMENT

Your CVA streamlines machine availability and cost control. It also includes machine alerts and easy access to asset information.

THE CAT DEALER NETWORK

Cat dealers are trained experts and can support you in making the best decisions for your machine, application, owning, and operating needs. Working with Caterpillar means more than just reaping the benefits of quality equipment, it means benefiting from quality relationships with the global network of Cat professionals who support your operation.

TOGETHER, WE'RE MINING BETTER

We're committed to helping customers mine better; whether through equipment or dealer-offered services. It's our mission to achieve the highest levels of safety, efficiency, productivity, and sustainability.

Thank you for being a Caterpillar customer. It's our pleasure to support your operation.



XXXXXXX

© 2024 Caterpillar. All Rights Reserved. CAT, CATERPILLAR, LET'S DO THE WORK, their respective logos, "Caterpillar Corporate Yellow", the "Power Edge" and Cat "Modern Hex" trade dress as well as corporate and product identity used herein, are trademarks of Caterpillar and may not be used without permission.

