



Image shown may not reflect actual configuration.

Cat[®] Energy Control System (ECS) 200

The Cat ECS 200 generator set controller uses system graphic icons and labels that allow for simple, comprehensive multiple generator set paralleling operation. The easy-to-use 203 mm (8") color LED touchscreen display features swipe-screen and scroll navigation. Generator set and remote-mount options are available.

FEATURES

- Island mode - Up to 32 generator sets with Cat ECS 200 control systems
- High visibility graphical touchscreen display with alarm/event descriptions, set points, engine and generator monitoring
- Meets UL 2200, 3rd Edition requirements including UL 6200
- Local annunciation to meet NFPA 110 (subject to local authority having jurisdiction approval)
- Ethernet Modbus TCP for external communications
- Intuitive navigation for display of power metering, protection, engine and generator parameters and tuning
- Lockout security provision to assure platform integrity with five programable security levels
- Support of up to four (4) remote HMI's (sold separately)
- Multi-language support.
- Compatibility with Cat Connect Product Link™ devices
- IVR or CDVR voltage regulation compatibility
- Emergency Override

Advanced Functionality

- Automatic mains failure w/ utility voltage sensing capability (open transition) and remote breaker or contactor control/monitoring
- Engine remote start integrity monitoring
- Generator circuit breaker control
- Single gen Transient Load Relief (TLR)
- Basic programmable logic control (PLC) function
- Base load w/utility featuring genset circuit breaker (GCB) control
- Embedded webserver
- EPA Tier 4 integration
- Real (kW) load histograms
- Status event logs
- Supports Dynamic Gas Blending™ (DGB™)
- Dead bus arbitration
- Failsafe Adaptive Load Sharing/Droop Operation

Control Module and Display

The Cat ECS 200 utilizes two Cat A6L3 modules and a high-resolution display for the human machine interface (HMI) for single generator set or paralleling applications.



Typical⁽¹⁾ Single Line Diagram (SLD)

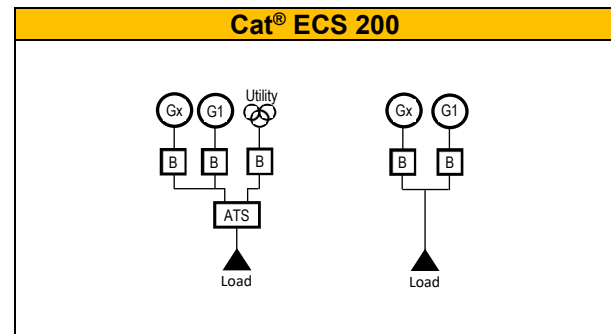

⁽¹⁾ - More single line diagrams (SLD's) are available to meet application requirements. Contact your local Cat dealer for more information.

Standard Features

Controls	<ul style="list-style-type: none"> • Auto / Start / Stop • Emergency stop • Engine cooldown timer • Engine cycle crank • Programmable cycle timer • Speed and voltage adjust
Generator Set Monitoring	<ul style="list-style-type: none"> • Generator AC voltage monitoring (+/- 0.25% controller lifetime accuracy) • Utility/Bus AC voltage monitoring (+/- 0.25% controller lifetime accuracy) • 3 phase/4 wire (L-L&L-N) sensing • Current sensing (3 phase/6 wire) (+/- 0.1% up to 100% of rated current controller accuracy) • Generator AC current (per phase & avg) • Generator frequency • Power metering (kW, kVA, kVA_r, pf) • kW-hr (export), kVA_r-hr (import and export), total and trip • Generator stator and bearing temp (with optional RTD module) • kW load histogram
Generator Protection	<ul style="list-style-type: none"> • Generator phase sequence (47G) • Over/Under voltage (27/59) • Over/Under frequency (81 O/U) • Overcurrent timed & inverse (50/51) • Overcurrent (Thermal Damage Curve) (51) • Reverse power real (kW) (32) • Reverse power reactive (kVA_r) (32RV) • Current balance (46) • Overload (49)
Engine Monitoring	<ul style="list-style-type: none"> • Engine oil pressure (kPa or psi) • Engine oil temperature (°C or °F) • Engine coolant temperature (°C or °F) • Engine speed (RPM) • Battery voltage • Crank attempt and successful start counter • Run hour meter • Real time clock
Engine Protection	<ul style="list-style-type: none"> • Control switch not in auto (alarm) • Low oil pressure • High coolant temperature (alarm and shutdown) • Low coolant temp (alarm) • Low coolant level (alarm and shutdown) • High engine oil temp (alarm and shutdown) • Low/High/Weak battery voltage • Fail to start • Overspeed • Overcrank • Low gas pressure (alarm and shutdown)

Standard Features *(continued)*

Digital Inputs	<ul style="list-style-type: none"> • Emergency Stop • Remote Start • Group Start • 32 programmable inputs (4 used for functional safety)⁽²⁾
Digital Outputs	<ul style="list-style-type: none"> • 24 programmable outputs (4 used for functional safety)⁽²⁾
Analog Outputs	<ul style="list-style-type: none"> • 4 analog outputs
PWM Outputs	<ul style="list-style-type: none"> • 6 Total (1 used for IVR - standard)
Analog Inputs	<ul style="list-style-type: none"> • 6 programmable inputs (0-5V, 0.5-4.5V, 1-5V, or resistive)⁽²⁾
Communication	<ul style="list-style-type: none"> • Primary & accessory CAN data link • Remote annunciator data link up to 1219 m (4000 ft) • Cat[®] Data Link (CDL) - with optional PLE702 • Ethernet (Modbus TCP/IP) - 100 baseT • USB- touchscreen display • Eight 4-wire ports for internal and customer use • Four 2-wire ports for internal device network
Environmental	<ul style="list-style-type: none"> • HMI (front touchscreen) IP66 • A6L3 Controller Operating Temp. -40°C to + 70°C • Control module box: <ul style="list-style-type: none"> - Ingress protection IP23 - Health Care Access and Information (HCAI) ground and roof seismic certification
Languages	<ul style="list-style-type: none"> • Chinese Danish English French German Italian Japanese Portuguese Russian Spanish additional languages on request

⁽²⁾ - Generator set configuration may affect available features.

Enhanced Control Features

Advanced overcurrent protection

The Cat ECS 200 provides advanced overcurrent protection of the generator set system via programmable Definite Time and Inverse Time curves.

For the Inverse time curve the following four selections are available:

- Normally Inverse
- Very Inverse
- Extremely Inverse
- Thermal Damage Curve - the Thermal Damage curve may be more closely aligned to specific generators.

Arc Flash Maintenance mode

The Cat ECS 200 Programmable Arc Flash Energy Reducing Maintenance Mode feature provides a method to reduce clearing time via two functions that work together to meet the 2023 edition of NFPA 70, Section 240.87 (Arc Energy Reduction).

- A means to accept an energy-reducing maintenance switch and provide means to connect a local status indicator.
- An instantaneous overcurrent setting that can be set below the available arcing current.

Integrated programmable logic controller (PLC)

This feature set of the Cat ECS 200 allows the user to create custom logic functions in similar fashion to that of the capability of a PLC controller. These logic functions allow for increased capability of the Cat ECS 200 through interaction and control of internal signals within the control software as well as the programmable inputs/outputs of the device.

Programmable kW relay

The Cat ECS 200 includes three programmable kW relay outputs configured based on the % kW of the generator set. The configurable set points of the kW relay include: trigger condition, percentage threshold, hysteresis percentage and trip activation & deactivation delay time. These output functions may also be used to trigger events, recordable within the event log and included in the remote monitoring of the generator set.

Real-time clock

The real-time clock allows for date and time stamping of diagnostics and events in the control's logs as well as service maintenance reminders based on engine operating hours or calendar days.

Diagnostic System and Status Event Logs

Up to 40 unique diagnostic events (e.g., warnings, shutdowns, etc.) are stored in the non-volatile memory of each A6L3. It also allows for the creation of a status event log for each A6L3. Each log holds the last 500 control events such as Engine Control Switch Position, Remote Initiate, Load Shed, etc. Events are stored in a "first in, first out" strategy.

Programmable cycle timer

The programmable cycle timer (PCT) feature allows for programming of seven independent times, when tasks (called PCT outputs), will be activated or deactivated automatically during the week. This is useful for exercising generator sets, or cases where two or more generators are required to automatically share the duty of supplying a load throughout the week. Using the PCT, each generator set can be programmed to start and stop at pre-set times. The PCT can handle a seven-day sequence with seven independent starts happening one or more times each week. Each of the seven timers has the following set points: activation day of the week, activation start time, active time and includes three (3) independent activation outputs.

Real (kW) load histogram

The Cat ECS 200 is equipped with a real (kW) load histogram. This feature keeps track of the amount of time the generator percent kW is within certain predefined ranges. The ranges monitored are in 10% steps (0 to <10%, 10% to <20%, ..., 90% to 100%).

HMI Webserver

The Cat ECS 200 HMIs include an embedded web server. The embedded web server allows the operator to operate a virtual HMI with the same control and permissions as the host HMI (local or remote, if applicable) over an Ethernet connection to a local and/or remote station. Custom screen creation is also available. Each HMI webserver is independent.

Paralleling Functions

Advanced Paralleling Control Data Link (APCDL)

This configuration utilizes an Ethernet-based communication protocol to accomplish the synchronizing and paralleling functions of the Cat ECS 200. This advanced communication methodology provides enhanced feature sets of the installed paralleling system, including feeder breaker control and advanced system monitoring and increased load sense demand features. The APCDL supports up to 32 generator sets and can support ring communication topology.

Dead Bus Arbitration

The Cat ECS 200 incorporates true dead bus arbitration to determine and select the primary generator set to close to a dead bus, allowing only one unit to close to the dead bus. The dead bus arbitration control minimizes the time for the first generator set to close to the dead bus.

Synchronizing

The Cat ECS 200 monitors all three phases of the generator and main bus. The proprietary synchronizing algorithms drive the generator output frequency, voltage, and phase to match another source, and close the GCB when conditions for synchronizing have been met.

Load Shed/Load Add

The Cat ECS 200 provides a configurable load add signal as generator set capacity becomes available. In the event of generator capacity becoming unavailable during operation, a configurable load shed signal is provided. Enhanced load shed/load add capability is available with the feeder breaker control option.

Load sharing

The Cat ECS 200 actively monitors the real (kW) and reactive (kVAr) load requirement of all paralleled generator sets and adjusts output of the generator set to maintain a balanced loading of all generator sets.

Soft Load/Unload

When load sharing, soft loading and soft unloading reduces instability and risk to the equipment by increasing or decreasing load in a controlled manner before closing or opening the GCB.

Load Sense/Load Demand (LSLD)

This feature is the control scheme used to automatically bring generator sets onto the bus or take generator sets off the bus to serve facility loads while maintaining fuel efficiency and adequate reserve. The LSLD control algorithm analyzes system load levels, sequences priority assignments and generator status communicated via the APCDL network.

Feeder Breaker Control

Feeder breaker control for connecting a generator bus and a load bus is included with the Cat ECS 200 operation. For this feature set, a programmable digital output is configured for a “Feeder Breaker Close Command” and/or “Feeder Breaker Trip Command” based on minimum real/reactive power required setpoints. The advanced programming capability of this feature allows for the controlled sequencing of multiple load shed/add stages.

Modes of Operation

• Automatic Paralleling

In the automatic paralleling mode, the Cat ECS 200 controller automatically adjusts the voltage and frequency of the generator set. When the generator output is synchronized with the second source, the controller closes the GCB.

• Manual Paralleling

In the manual paralleling mode, the operator will manually adjust the voltage and frequency of the generator set. When the generator set is synchronized with the second source, the operator will initiate a generator circuit breaker close command. A 3-phase sync check function is also included to prevent out of phase paralleling.

• Sync Check Mode

In the sync check mode, the Cat ECS 200 controller automatically adjusts the voltage and frequency of the generator set without closing the GCB. When the generator set is synchronized with the second source, the operator will initiate a generator circuit breaker close command. A 3-phase sync check function is also included to prevent out of phase paralleling.

Failsafe Adaptive Load Sharing/Droop Operation

The Cat ECS 200 safely maintains stability through a loss of communication, seamlessly transitioning into failsafe mode with gradual, stable movement to a new equilibrium point.

Optional Modules

Off Package HMI

The Cat ECS 200 supports up to four (4) optional full function off package HMI displays with the addition of an unmanaged Ethernet switch. The interactive 203 mm (8") color touchscreen graphical interface serves to display generator set system alarm conditions, status indications and annunciation (with RCA output) to meet NFPA110 (subject to local authority having jurisdiction approval).



RS-485 Remote Annunciator

The remote RS-485 annunciator serves to display genset system alarm conditions and status indications for 16 points with a standard NFPA 99 & 110 label. The annunciator has been designed for use on the long-distance annunciator datalink and may be used off package up to 1220m (4000 feet) applications. A maximum of four (4) annunciators may be used with a Cat ECS 200.



See LEHE21395

Expansion Input/Output Ethernet Modules

- Supports expanded Inputs/Outputs (IO) capability of the Cat ECS 200 control:
 - Analog & digital I/O
 - Temperature sensing (RTD)
- Configure I/O for any event (read & write function)
- Package mounted and/or ship loose options

See LEHE22466

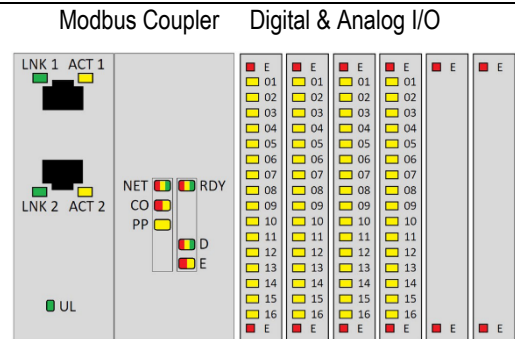

Optional Modules(*continued*)

Digital Input/Output Module

The Digital Input/Output (DI/O) module serves to provide expandable Input and Output for any event and is capable of reading 12 discrete inputs to trigger system events and setting 8 relay outputs based on system events. The DI/O module has been designed for use on the accessory communication network and may be used in either local (package mounted) or off package up to 244 m (800 feet) applications. A maximum of four DI/O modules may be used with a Cat ECS 200.



See LEHE21394

RTD Module

The RTD module serves to provide expandable generator temperature monitoring capability of the Cat ECS 200 control system and is capable of reading up to eight 2-wire, 3-wire and 4-wire RTD inputs. The RTD Module has been designed for use on the accessory communication network and may be used in either local (package mounted) or off package up to 244 m (800 feet) applications. A maximum of one RTD Module may be used with a Cat ECS 200.

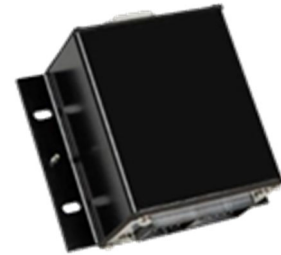

See LEHE21396

Dimensions

Package-Mounted or Ship Loose (with harness)



Image shown may not reflect actual configuration.

Dimensions				
Control Box Dimensions	A	B	C ⁽³⁾	Weight
Units	mm (in)	mm (in)	mm (in)	kg (lbs)
Cat ECS 200	1345 (52.95)	710 (27.95)	216 (8.50)	70 (154)

⁽³⁾ - Dimension including E-Stop button is 263 mm (10.35 in).

Worldwide Product Support

Cat dealers have over 1,800 dealer branch stores operating in 200 countries and offer extensive post-sale support including maintenance and repair agreements

Materials and specifications are subject to change without notice.
The International System of Units (SI) is used in this publication.

© 2024 Caterpillar. All Rights Reserved. CAT, CATERPILLAR, LET'S DO THE WORK, their respective logos, "Caterpillar Corporate Yellow", the "Power Edge" and Cat "Modern Hex" trade dress as well as corporate and product identity used herein, are trademarks of Caterpillar and may not be used without permission.

www.cat.com/electricpower