



Image shown may not reflect actual configuration.

## Cat<sup>®</sup> Energy Control System (ECS) 100

The Cat ECS 100 generator set controller uses system graphic icons and labels that allow for simple, comprehensive generator set operation. The easy-to-use 203 mm (8") color LED touchscreen display features swipe-screen and scroll navigation. Generator set and remote-mount options are available.

### FEATURES

- Island mode – single unit operation
- High visibility graphical touchscreen display with alarm/event descriptions, set points, engine and generator monitoring
- Meets UL 2200, 3rd Edition requirements including UL 6200
- Local annunciation to meet NFPA 110 (subject to local authority having jurisdiction approval)
- Ethernet Modbus TCP for external communications
- Intuitive navigation for display of power metering, protection, engine and generator parameters and tuning
- Lockout security provision to assure platform integrity with three programmable security levels
- Support of up to four (4) remote HMI's (sold separately)
- Multi-language support.
- Compatible with Cat Connect Product Link™ devices
- IVR or CDVR voltage regulation compatibility
- Emergency Override

### Advanced Functionality

- Automatic mains failure with utility voltage sensing capability (open transition) and remote breaker or contactor control/monitoring
- Engine remote start integrity monitoring
- Single genset transient load relief (TLR)
- Basic programmable logic control (PLC) function
- Embedded webserver
- EPA Tier 4 integration
- Real (kW) load histograms
- Status event log
- Supports Dynamic Gas Blending™ (DGB™)

### Control Module and Display

The Cat A6L3 is the base module controller utilizing the high-resolution display for the human machine interface (HMI).



### Typical<sup>(1)</sup> Single Line Diagram (SLD)

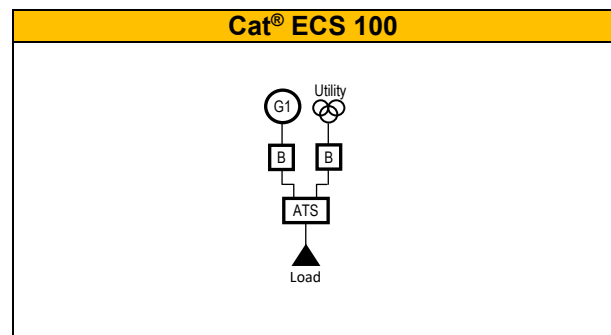

<sup>(1)</sup> - More single line diagrams (SLD's) are available to meet application requirements. Contact your local Cat dealer for more information.

## Standard Features

<b>Controls</b>	<ul style="list-style-type: none"> <li>• Auto / Start / Stop</li> <li>• Emergency stop</li> <li>• Engine cooldown timer</li> <li>• Engine cycle crank</li> <li>• Programmable cycle timer</li> <li>• Speed and voltage adjust</li> </ul>
<b>Generator Set Monitoring</b>	<ul style="list-style-type: none"> <li>• Generator AC voltage monitoring (+/- 0.25% controller lifetime accuracy)</li> <li>• Utility/Bus AC voltage monitoring (+/- 0.25% controller lifetime accuracy)</li> <li>• 3 phase/4 wire (L-L&amp;L-N) sensing</li> <li>• Current sensing (3 phase/6 wire) (+/- 0.1% up to 100% of rated current controller accuracy)</li> <li>• Generator AC current (per phase &amp; avg)</li> <li>• Generator frequency</li> <li>• Power metering (kW, kVA, kVA<sub>r</sub>, pf)</li> <li>• kW-hr (export), kVA<sub>r</sub>-hr (import and export), total and trip</li> <li>• Generator stator and bearing temp (with optional RTD module)</li> <li>• kW load histogram</li> </ul>
<b>Generator Protection</b>	<ul style="list-style-type: none"> <li>• Generator phase sequence (47G)</li> <li>• Over/Under voltage (27/59)</li> <li>• Over/Under frequency (81 O/U)</li> <li>• Overcurrent timed &amp; inverse (50/51)</li> <li>• Overcurrent (Thermal Damage Curve) (51)</li> <li>• Reverse power real (kW) (32)</li> <li>• Reverse power reactive (kVA<sub>r</sub>) (32RV)</li> <li>• Current balance (46)</li> <li>• Overload (49)</li> </ul>
<b>Engine Monitoring</b>	<ul style="list-style-type: none"> <li>• Engine oil pressure (kPa or psi)</li> <li>• Engine oil temperature (°C or °F)</li> <li>• Engine coolant temperature (°C or °F)</li> <li>• Engine speed (RPM)</li> <li>• Battery voltage</li> <li>• Crank attempt and successful start counter</li> <li>• Run hour meter</li> <li>• Real time clock</li> </ul>
<b>Engine Protection</b>	<ul style="list-style-type: none"> <li>• Control switch not in auto (alarm)</li> <li>• Low oil pressure</li> <li>• High coolant temperature (alarm and shutdown)</li> <li>• Low coolant temp (alarm)</li> <li>• Low coolant level (alarm and shutdown)</li> <li>• High engine oil temp (alarm and shutdown)</li> <li>• Low/High/Weak battery voltage</li> <li>• Fail to start</li> <li>• Overspeed</li> <li>• Overcrank</li> <li>• Low gas pressure (alarm and shutdown)</li> </ul>

## Standard Features *(continued)*

<b>Digital Inputs</b>	<ul style="list-style-type: none"> <li>• Emergency Stop</li> <li>• Remote Start</li> <li>• 16 programmable inputs (4 used for functional safety)<sup>(2)</sup></li> </ul>
<b>Digital Outputs</b>	<ul style="list-style-type: none"> <li>• 12 programmable outputs (4 used for functional safety)<sup>(2)</sup></li> </ul>
<b>Analog Outputs</b>	<ul style="list-style-type: none"> <li>• 2 analog outputs</li> </ul>
<b>PWM Outputs</b>	<ul style="list-style-type: none"> <li>• 3 Total (1 used for IVR - standard)</li> </ul>
<b>Analog Inputs</b>	<ul style="list-style-type: none"> <li>• 3 programmable inputs (0-5V, 0.5-4.5V, 1-5V, or resistive)<sup>(2)</sup></li> </ul>
<b>Communication</b>	<ul style="list-style-type: none"> <li>• Primary &amp; accessory CAN data link</li> <li>• Remote annunciator data link up to 1219 m (4000 ft)</li> <li>• Cat<sup>®</sup> Data Link (CDL) - with optional PLE702</li> <li>• Ethernet (Modbus TCP/IP) - 100 baseT</li> <li>• USB- touchscreen display</li> <li>• Four 4-wire ports for internal and customer use</li> <li>• Two 2-wire ports for internal device network</li> </ul>
<b>Environmental</b>	<ul style="list-style-type: none"> <li>• HMI (front touchscreen) IP66</li> <li>• A6L3 Controller Operating Temp. -40°C to + 70°C</li> <li>• Control module box:                             <ul style="list-style-type: none"> <li>- Ingress protection IP23</li> <li>- Health Care Access and Information (HCAI) ground and roof seismic certification</li> </ul> </li> </ul>
<b>Languages</b>	<ul style="list-style-type: none"> <li>• Chinese   Danish   English   French   German   Italian   Japanese  </li> <li>• Portuguese   Russian   Spanish   additional languages on request  </li> </ul>

<sup>(2)</sup> - Generator set configuration may affect available features.

## Enhanced Control Features

### Advanced overcurrent protection

The Cat ECS 100 provides advanced overcurrent protection of the generator set system via programmable Definite Time and Inverse Time curves.

For the Inverse time curve the following four selections are available:

- Normally Inverse
- Very Inverse
- Extremely Inverse
- Thermal Damage Curve - the Thermal Damage curve may be more closely aligned to specific generators.

### Arc Flash Maintenance mode

The Cat ECS 100 Programmable Arc Flash Energy Reducing Maintenance Mode feature provides a method to reduce clearing time via two functions that work together to meet the 2023 edition of NFPA 70, Section 240.87 (Arc Energy Reduction).

- A means to accept an energy-reducing maintenance switch and provide means to connect a local status indicator.
- An instantaneous overcurrent setting that can be set below the available arcing current.

### Integrated programmable logic controller (PLC)

This feature set of the Cat ECS 100 allows the user to create custom logic functions in similar fashion to that of the capability of a PLC controller. These logic functions allow for increased capability of the Cat ECS 100 through interaction and control of internal signals within the control software as well as the programmable inputs/outputs of the device.

### Programmable kW relay

The Cat ECS 100 includes three programmable kW relay outputs configured based on the % kW of the generator set. The configurable set points of the kW relay include: trigger condition, percentage threshold, hysteresis percentage and trip activation & deactivation delay time. These output functions may also be used to trigger events, recordable within the event log and included in the remote monitoring of the generator set.

### Real-time clock

The real-time clock allows for date and time stamping of diagnostics and events in the control's logs as well as service maintenance reminders based on engine operating hours or calendar days.

### Diagnostic System and Status Event Logs

Up to 40 unique diagnostic events (e.g., warnings, shutdowns, etc.) are stored in the non-volatile memory. It also allows for the creation of a status event log. This log holds the last 500 control events such as Engine Control Switch Position, Remote Initiate, Load Shed, etc. Events are stored in a "first in, first out" strategy.

### Programmable cycle timer

The programmable cycle timer (PCT) feature allows for programming of seven independent times, when tasks (called PCT outputs), will be activated or deactivated automatically during the week. This is useful for exercising generator sets, or cases where two or more generators are required to automatically share the duty of supplying a load throughout the week. Using the PCT, each generator set can be programmed to start and stop at pre-set times. The PCT can handle a seven-day sequence with seven independent starts happening one or more times each week. Each of the seven timers has the following set points: activation day of the week, activation start time, active time and includes three (3) independent activation outputs.

### Real (kW) load histogram

The Cat ECS 100 is equipped with a real (kW) load histogram. This feature keeps track of the amount of time the generator percent kW is within certain predefined ranges. The ranges monitored are in 10% steps (0 to <10%, 10% to <20%, ..., 90% to 100%).

### HMI Webserver

The Cat ECS 100 HMIs include an embedded web server. The embedded web server allows the operator to operate a virtual HMI with the same control and permissions as the host HMI (local or remote, if applicable) over an Ethernet connection to a local and/or remote station. Custom screen creation is also available. Each HMI webserver is independent.

## Optional Modules

### Off Package HMI

The Cat ECS 100 supports up to four (4) optional full function off package HMI displays with the addition of an unmanaged Ethernet switch. The interactive 203 mm (8") color touchscreen graphical interface serves to display generator set system alarm conditions, status indications and annunciation (with RCA output) to meet NFPA110 (subject to local authority having jurisdiction approval).

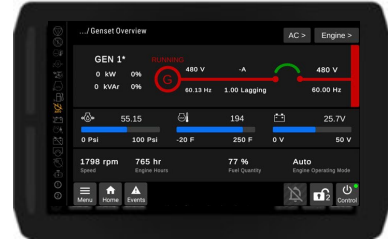

### RS-485 Remote Annunciator

The remote RS-485 annunciator serves to display genset system alarm conditions and status indications for 16 points with a standard NFPA 99 & 110 label. The annunciator has been designed for use on the long-distance annunciator datalink and may be used off package up to 1220m (4000 feet) applications. A maximum of four (4) annunciators may be used with a Cat ECS 100.

See LEHE21395.



### Expansion Input/Output Ethernet Modules

- Supports expanded Inputs/Outputs (IO) capability of the Cat ECS 100 control:
  - Analog & digital I/O
  - Temperature sensing (RTD)
- Configure I/O for any event (read & write function)
- Package mounted and/or ship loose options

See LEHE22466

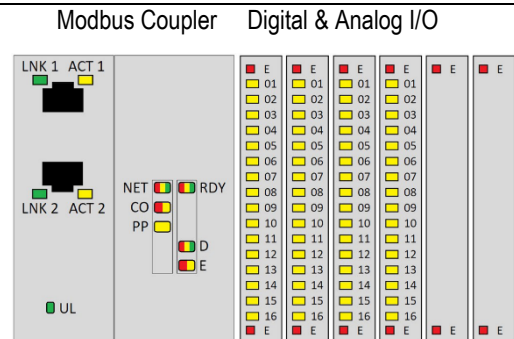

## Optional Modules(*continued*)

---

### Digital Input/Output Module

The Digital Input/Output (DI/O) module serves to provide expandable Input and Output for any event and is capable of reading 12 discrete inputs to trigger system events and setting 8 relay outputs based on system events. The DI/O module has been designed for use on the accessory communication network and may be used in either local (package mounted) or off package up to 244 m (800 feet) applications. A maximum of four DI/O modules may be used with a Cat ECS 100.



See LEHE21394

---

### RTD Module

The RTD module serves to provide expandable generator temperature monitoring capability of the Cat ECS 100 control system and is capable of reading up to eight 2-wire, 3-wire and 4-wire RTD inputs. The RTD Module has been designed for use on the accessory communication network and may be used in either local (package mounted) or off package up to 244 m (800 feet) applications. A maximum of one RTD Module may be used with a Cat ECS 100.



See LEHE21396

---

## Dimensions

Package-Mounted or Ship Loose (with harness)

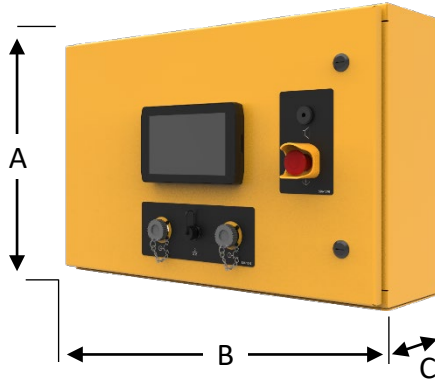

Image shown may not reflect actual configuration.

Dimensions				
Control Box Dimensions	A	B	C <sup>(3)</sup>	Weight
Units	mm (in)	mm (in)	mm (in)	kg (lbs)
Cat ECS 100	465 (18.31)	710 (27.95)	216 (8.50)	43 (95)

<sup>(3)</sup> - Dimension including E-Stop button is 263 mm (10.35 in).

## Worldwide Product Support

Cat dealers have over 1,800 dealer branch stores operating in 200 countries and offer extensive post-sale support including maintenance and repair agreements

Materials and specifications are subject to change without notice.  
The International System of Units (SI) is used in this publication.

© 2024 Caterpillar. All Rights Reserved. CAT, CATERPILLAR, LET'S DO THE WORK, their respective logos, "Caterpillar Corporate Yellow", the "Power Edge" and Cat "Modern Hex" trade dress as well as corporate and product identity used herein, are trademarks of Caterpillar and may not be used without permission.

[www.cat.com/electricpower](http://www.cat.com/electricpower)