

# EMD® 1010 T4 LOCOMOTIVE ENGINE

**Progress Rail**  
A Caterpillar Company

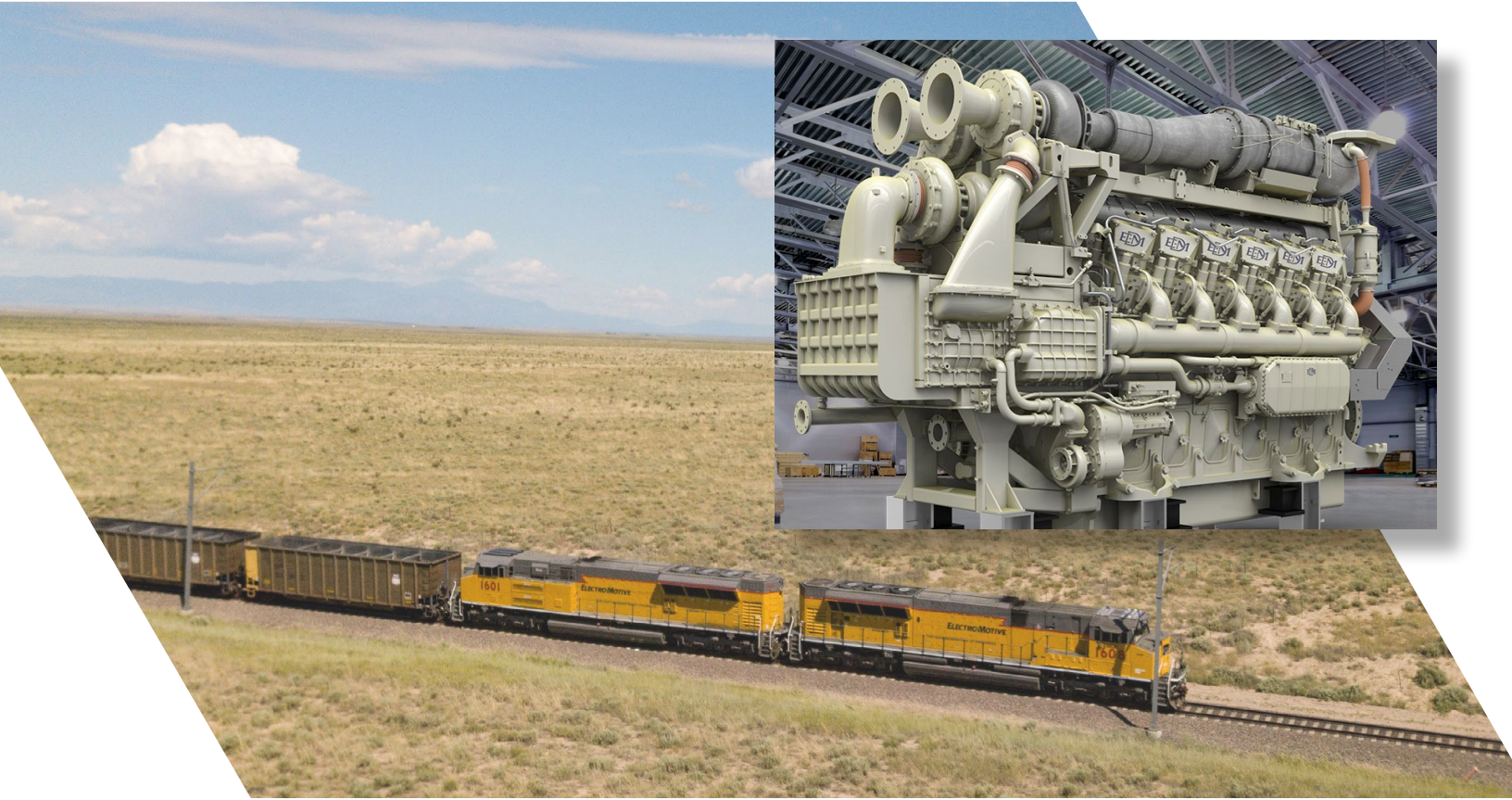

Developed using the combined engineering expertise of Progress Rail and Caterpillar, our EMD 4,500 BHP 1010™ engine achieves world-class fuel efficiency while meeting U.S. EPA Tier 4 emissions standards without aftertreatment system.

### Modular Common Rail Fuel System

High injection pressure improves combustion to reduce fuel consumption, emissions and improves response. Double walled fuel lines provide increased safety and simplified maintenance.

### Two-Stage Turbocharging

EMD turbos are custom designed to optimize locomotive performance across operating environments

### Isolated Engine Design

The unique isolation design improves ride quality and reduces cab noise.

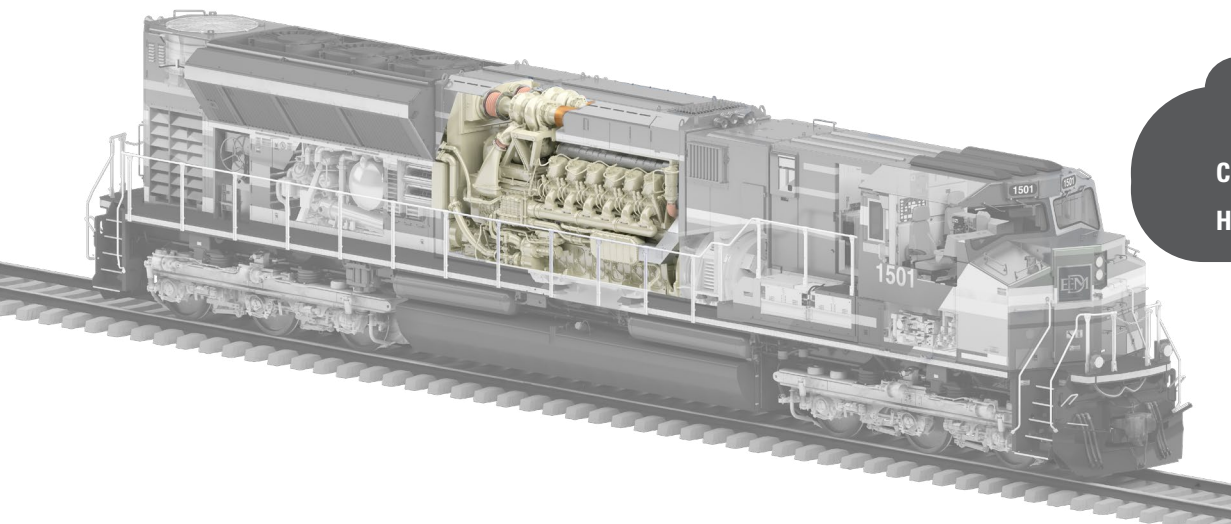

### Emissions Reduction Rates:

CO<sub>2</sub> (70%)    PM (90%)  
HC (80%)    NO<sub>x</sub> (80%)

LEARN  
MORE



CONTACT US +1 800-476-8769  
ProgressRail.com

FOLLOW US

