



# D6N DOZER

SERIAL NUMBER PREFIXES: DJA, DJY, GHS, JAH, LJR, MLW, PBA, PER

# PARTS REFERENCE GUIDE

**LET'S DO THE WORK.™**



# PROTECT YOUR INVESTMENT WITH GENUINE CAT® PARTS

Thank you for selecting the Cat® D6N Medium Dozer.

This guide is designed to provide you with a quick reference for the parts and part numbers you need to keep your Cat D6N medium dozer running at peak efficiency. Always read and understand the machine's Operation and Maintenance Manual prior to performing any type of maintenance.



## MAINTENANCE

Proactive preventative maintenance extends the life of your machine and protects your investment. Only Caterpillar knows Cat equipment's filtration and lubrication requirements and offers parts kits to match your machine's maintenance cycles.

SCHEDULED MAINTENANCE PARTS	
	GREASES
	PLANNED MAINTENANCE

## REPLACEMENT PARTS

Proper maintenance minimizes the need for repair and replacement. In the event that replacement parts are required, the use of genuine Cat parts helps maximize machine performance and maintains high resale value.

WEAR PARTS	
	LINKAGE PINS AND HARDWARE
	GROUND ENGAGING TOOLS
REPAIR PARTS	
	CAB ACCESSORIES
	MIRRORS AND LIGHTS
	MISCELLANEOUS

## OIL AND GREASE OPTIONS

GREASES	STANDARD MAINTENANCE GREASES			
	Previous Cat Product Name	Cat Ultra5 Moly #1	Cat Ultra5 Moly #2	Cat Advanced 3 Moly
Current Cat Product Name	Cat Extreme Application Grease 1	Cat Extreme Application Grease 2	Cat Prime Application Grease	
Grade (NLGI)	1	2	2	
Melting Point C° (F°)	260 (500)	260 (500)	260 (500)	
Ambient Temperature C° (F°)	-35 to +40 (-31 to +104)	30 to +50 (-22 to +122)	-20 to +40 (-4 to +104)	
Base Oil Type	Mineral	Mineral	Mineral	
Color	Dark Grey	Dark Grey	Dark Grey	
Cartridge (390 g / 14 oz)	452-5996	452-6001	452-6006	
Plastic Pail (5 kg / 11 lb)	-	-	-	
Plastic Pail (16 kg / 35 lb)	452-5999	452-6004	452-6009	
Keg (55 kg / 120 lb)	452-5998	452-6003	452-6008	
Drum (180 kg / 400 lb)	452-5997	452-6002	452-6007	

GREASES FOR UNIQUE APPLICATIONS AND ENVIRONMENTS	
Cat Arctic Platinum	Cat Desert Gold
Cat Extreme Application Grease - Arctic	Cat Extreme Application Grease - Desert
0	2
230 (446)	280 (536)
-35 to +40 (-31 to +104)	30 to +50 (-22 to +122)
Semi-Synthetic	Mineral
Dark Grey	Dark Grey
508-2184	452-6016
-	-
508-2187	452-6019
508-2186	452-6018
508-2185	452-6017

ENGINE OIL OPTIONS		
Part Number	Part Name	Amount
515-3973	Cat DEO - CK-4 SAE 15W-40 (**)	1 Gal (3.8 L)
515-3974		2.5 Gal (9.4 L)
515-3975		5 Gal (18.9 L)
515-3985	Cat DEO - CK-4 SAE 10W-30 (**)	Four, 1 Gal (3.8 L) Containers
515-3986		2.5 Gal (9.4 L)
515-3987		5 Gal (18.9 L)
515-3993	Cat DEO - CK-4 SAE 5W-40 (**)	1 Gal (3.8 L)
524-8573		5 Gal (18.9 L)
DIESEL EXHAUST FLUID (DEF)		
Part Number	Part Name	Amount
350-8733 (*)	32.5% UREA	2.5 Gal (9.4 L)
FINAL DRIVE OIL OPTIONS		
Part Number	Part Name	Amount
184-6022	Cat® FDAO™	5 Gal (18.9 L)
208-2390	Cat® FDAO SYN™	

POWER TRAIN OIL OPTIONS		
Part Number	Part Name	Amount
462-7706	Cat® TDTO™ 10W	2.5 Gal (9.4 L)
8T-9568		5 Gal (18.9 L)
248-7521	Cat® TDTO™ 30W	1 Gal (3.8 L)
462-7708		2.5 Gal (9.4 L)
8T-9572		5 Gal (18.9 L)
462-7709	Cat® TDTO™ 50W	2.5 Gal (9.4 L)
8T-9576		5 Gal (18.9 L)
HYDRAULIC OIL OPTIONS		
Part Number	Part Name	Amount
309-6932	Cat® HYDO™ Advanced 10W	Four, 1 Gal (3.8 L) Containers
462-7710		2.5 Gal (9.4 L)
309-6931		5 Gal (18.9 L)
422-6704	Cat® HYDO™ Advanced 20W	1 Gal (3.8 L)
469-0585		2.5 Gal (9.4 L)
422-6705		5 Gal (18.9 L)

COOLANT					
Cat ELC® PREMIX Lowers maintenance costs and ensures Extended Life Coolant			Cat ELC® EXTENDER Ensures Extended Life Coolant performance		Cooling Conditioner for Aluminum Components
1.3 Gal (5 L)	5.2 Gal (20 L)	55 Gal (210 L)	30 oz (0.9 L)	1 Gal (3.8 L)	2.5 oz (74 ml)
205-6611	205-6612	205-6613	119-5152	210-0786	369-0805

Up to 12,000 hours (or 6 years) drain interval with an addition of Cat® Extender at 6,000 hours and yearly S•O•S™ coolant sampling analysis.  
 (\*) : EU Stage V engines only (\*\*) : ULS Oil Required for countries with advanced emissions standards and recommended for all other countries.

# PLANNED MAINTENANCE

MEDIUM DOZER		Every 10 Hours or Daily
		Cab
Sales Model	Serial Number Prefix	Recirculation Filter (Clean/Inspect/Replace)
D6N	JAH, DJA, DJY, LJR, MLW, GHS	7G-8116
	PBA, PER	151-0914

MEDIUM DOZER		Every 50 Hours
		Cab
Sales Model	Serial Number Prefix	Recirculation Filter (Clean/Inspect/Replace)
D6N	JAH, DJA, DJY, LJR, MLW, GHS, PBA, PER	329-3243

MEDIUM DOZER		Intital 250 Hours		
		Engine	Fuel	
Sales Model	Serial Number Prefix	Oil Filter	Oil Quantity - Gallon (L)	In-line Filter
D6N	JAH, DJA, DJY, LJR, MLW, GHS	462-1171	4.2 (16)	-
	PBA, PER			525-6205

MEDIUM DOZER		Every 250 Hours
		Engine
Sales Model	Serial Number Prefix	Belt (Inspect/Replace)
D6N	JAH, DJA, DJY, LJR, MLW, GHS	253-4531

MEDIUM DOZER		Initial 500 Hours
		Engine
Sales Model	Serial Number Prefix	Engine Valve Lash / Gasket
D6N	JAH, DJA, DJY, LJR, MLW, GHS	317-3064

MEDIUM DOZER		Every 500 Hours										
		Engine			Fuel				Hydraulic			
Sales Model	Serial Number Prefix	Air Filter - Primary Element	Oil Filter	Oil Quantity - Gallon (L)	In-line Filter	Primary Filter	Secondary Filter	Third Filter	Fuel Cap Filter	Filter	Filter Gasket	Steering Charge Filter
D6N	JAH, DJA, DJY	252-5001	462-1171	4.2 (16)	-	326-1644	308-1502	1R-0751	350-7735	1R-0777# 139-1537## 104-6931###	6V-9633	1G-8878
	319-0844						306-9199					
	PBA, PER	539-6920* 528-7222**		4.5 (17)	525-6205	479-4131 460-0310 (Retrofit Kit)	360-8930	-	349-7059			348-1862



\*For use with square shaped air cleaner housing.  
 \*\*For use with circular shaped air cleaner housing.  
 #When using Advanced Efficiency hydraulic fluid  
 ##When using Ultra High Efficiency hydraulic fluid  
 ###When using Fire Resistant hydraulic fluid

# PLANNED MAINTENANCE

MEDIUM DOZER		Every 1,000 Hours		Every 1,000 Hours or 6 Months		
		Engine		Power Train		Winch
Sales Model	Serial Number Prefix	Engine Valve Lash / Gasket	Belt	Transmission Filter	Oil - Quantity Gallon (L)	Oil - Quantity Gallon (L)
D6N	JAH, DJA, DJY, LJR, MLW, GHS	317-3064	-	328-3655	42.3 (160)	-
D6N	PBA, PER	-	348-7886	337-5270		19,5 (73,8)

MEDIUM DOZER		Every 1500 Service Hours	
		Engine	
Sales Model	Serial Number Prefix	Air Filter - Secondary Element	Engine Crankcase Breather Filter
D6N	PBA, PER	346-6694* 529-0132**	339-1048

\*For use with square shaped air cleaner housing.

\*\*For use with circular shaped air cleaner housing.

MEDIUM DOZER		Every 2,000 Hours or 1 Year		Every Year
		Final Drive (each)	Hydraulic Tank	Air Conditioning
Sales Model	Serial Number Prefix	Oil - Quantity Gallon (L)	Oil - Quantity Gallon (L)	Refrigerant Dryer - Replace
D6N	JAH, DJA, DJY, LJR, MLW, GHS	1.8 (7.0)	7.8 (29.5)	-
	PBA, PER			257-3226

MEDIUM DOZER		Every 2 Years		Every 3000 Hours or 2 Years	
		Engine		Engine	
Sales Model	Serial Number Prefix	Air Filter Primary Element	Air Filter Secondary Element	Thermostat	Serpentine Belt (Inspect/Replace)
D6N	JAH, DJA, DJY	252-5001	252-5002	417-7782 - Thermostat	-
	LJR, MLW, GHS			281-8744 - Gasket	
	PBA, PER	539-6920* 528-7222**	-	123-2899 - Bolt (Quantity 2)	
				497-3989 - Thermostat	348-7886
				61-0254 - Bolt (Quantity 3)	

\*For use with square shaped air cleaner housing.

\*\*For use with circular shaped air cleaner housing.

MEDIUM DOZER		Every 3 Years
		Cab
Sales Model	Serial Number Prefix	Seat Belt
D6N	JAH, DJA, DJY, LJR, MLW, GHS, PBA, PER	222-0345

MEDIUM DOZER		Every 6,000 Hours or 3 Years
		Cooling System
Sales Model	Serial Number Prefix	Coolant Extender (ELC) Quart (L)
D6N	JAH, DJA, DJY, LJR, MLW, GHS, PBA, PER	0.84 (0.8)

MEDIUM DOZER		Every 12,000 Hours or 6 Years
		Cooling System
Sales Model	Serial Number Prefix	Coolant - Gallons (L)
D6N	JAH, DJA, DJY, LJR, MLW, GHS	9.2 (35)
	PBA, PER	9.5 (36)

MEDIUM DOZER		When Required									
		Cabin Air	Engine			Cooling System	Fuel			Winch	
Sales Model	Serial Number Prefix	Fresh Air Filter	Air Filter Primary Element	Air Filter Secondary Element	Ether Cylinder	Radiator Cap	Primary Filter	Secondary Filter	Third Filter	Fuel Cap Filter	Winch Cable
D6N	JAH, DJA, DJY	7G-8116	252-5001	252-5002	7N-0296	287-5256	326-1644	308-1502	1R-0751	350-7735	-
	LJR, MLW, GHS							319-0844	306-9199		
	PBA, PER	151-0914	539-6920* 528-7222**	346-6694* 529-0132**	7N-0297	345-1237	479-4131 460-0310 (Retrofit Kit)	360-8930	-	349-7059	

\*For use with square shaped air cleaner housing.

\*\*For use with circular shaped air cleaner housing.

### LINKAGE PIN - RIPPER

Sales Model	Serial Number Prefix	Ripper - Fixed Parallelogram					
		AA	BB	CC	DD	EE	FF
D6N	DJY, DJA, JAH	(Quantity 2) 1U-0159 Pin	(Quantity 2) 1U-0159 Pin	3K-8510 Pin	(Quantity 2) 4K-3004 Trunnion Bearing	(Quantity 2) 1U-0063 Pin	(Quantity 2) 9J-9598 Pin
	LJR, GHS, MLW						
	PER, PBA						

### BUSHINGS - RIPPER

Sales Model	Serial Number Prefix	Ripper - Fixed Parallelogram					
		AA	BB	CC	DD	EE	FF
D6N	DJY, DJA, JAH	(Quantity 2) 9W-0099 Bushing	(Quantity 2) 9W-0099 Bushing	2K-4507 Bushing	(Quantity 2) 4K-3128 Bushing	(Quantity 2) 7J-9682 Bushing	(Quantity 2) 7J-9682 Bushing
	LJR, GHS, MLW						
	PER, PBA						



# DOZER - STRAIGHT/SEMI UNIVERSE

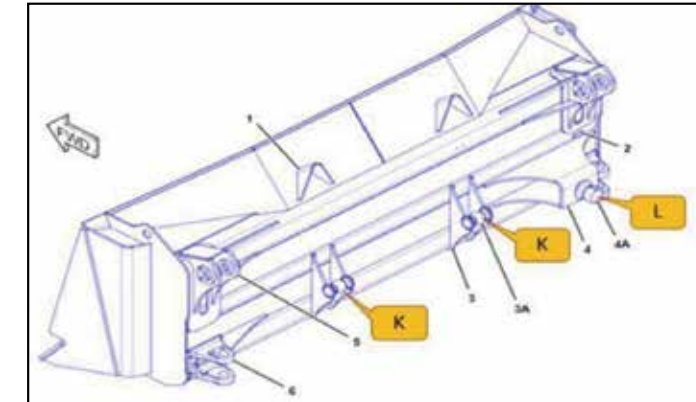
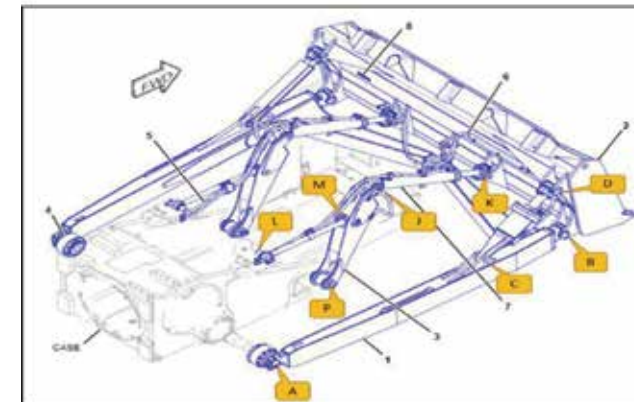
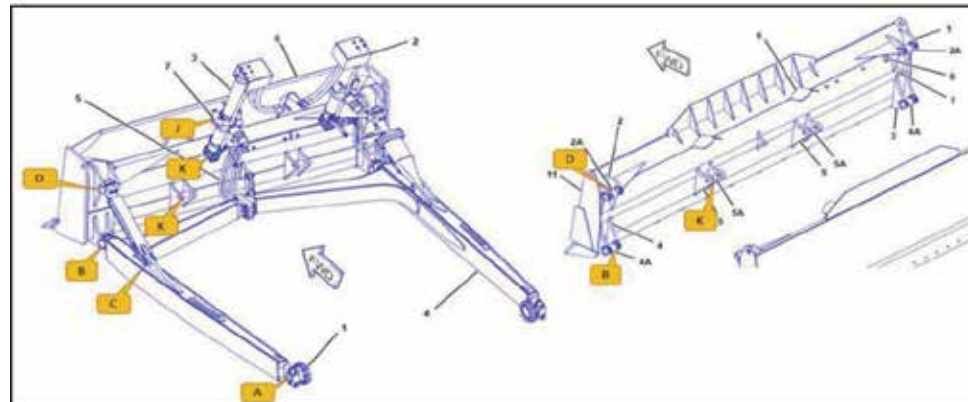
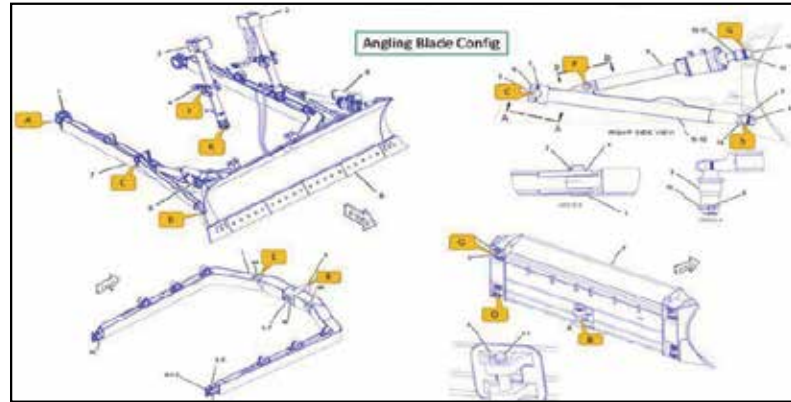

LINKAGE PIN - BLADE										
Sales Model	Serial Number Prefix	Blade - L Shaped								
		A	B	C	D	J	K	L	M	P
D6N	DJY, DJA, JAH	(Quantity 2) 287-5751 Trunnion	(Quantity 2) 4J-1641 Trunnion	(Quantity 2) 3F-6185 Pin	(Quantity 2) 7J-5131 Trunnion	(Quantity 2) 479-5795 Pin	(Quantity 2) 4T-1504 Trunnion	(Quantity 2) 479-1462 Pin	(Quantity 2) 479-5795 Pin	(Quantity 2) 480-0976 Pin
	LJR, GHS, MLW	9J-2759 Trunnion				(Quantity 2) 479-5795 Pin		(Quantity 2) 479-1462 Pin	(Quantity 2) 479-5795 Pin	(Quantity 2) 480-0976 Pin
	PER, PBA	-	-	-	-	-	-	-	-	-

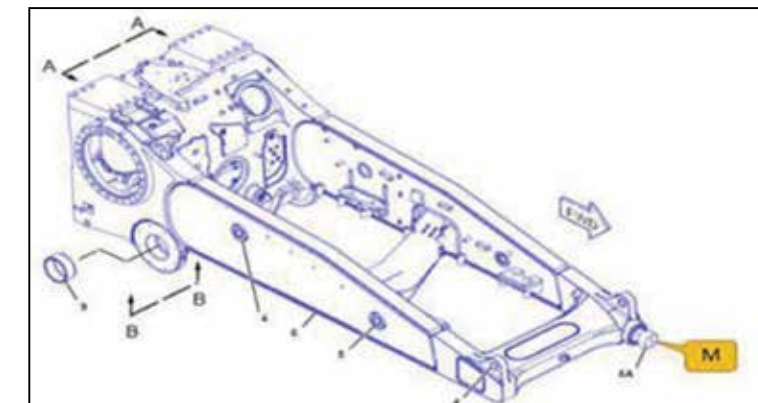

BEARINGS AND BUSHINGS - BLADE								
Sales Model	Serial Number Prefix	Blade - L Shaped						
		A	B	C	D	J	K	P
D6N	DJY, DJA, JAH	(Quantity 2) 3G-6313 Bearing	(Quantity 2) 179-6153 Bearing	2J-8489 Bearing (Right)	(Quantity 2) 8J-2880 Bearing Cap	(Quantity 2) 9J-7964 Bearing	(Quantity 2) 4J-0121 Bearing Cap	(Quantity 2) 115-4561 Bushing
	LJR, GHS, MLW	(Quantity 2) 160-6306 Bearing Cap	(Quantity 2) 8J-2880 Bearing Cap					

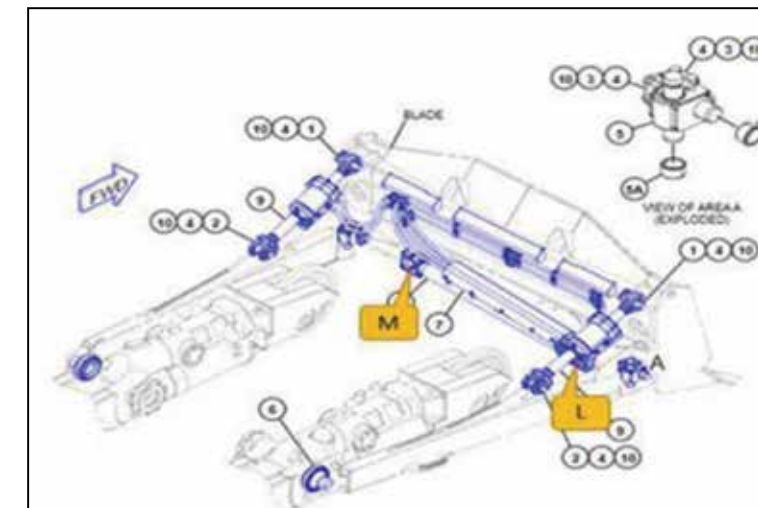

# DOZER - VPAT/ANGLING

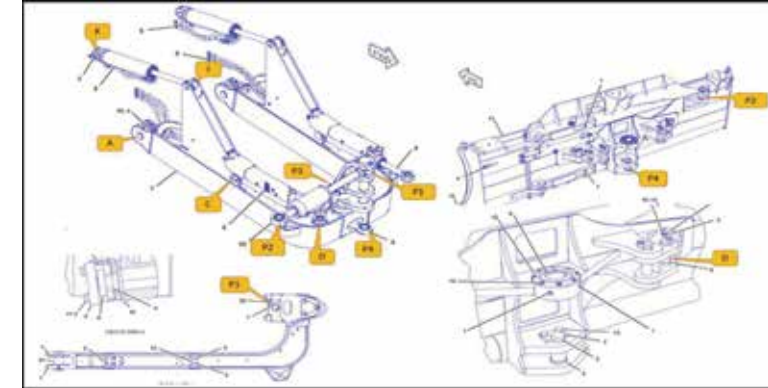
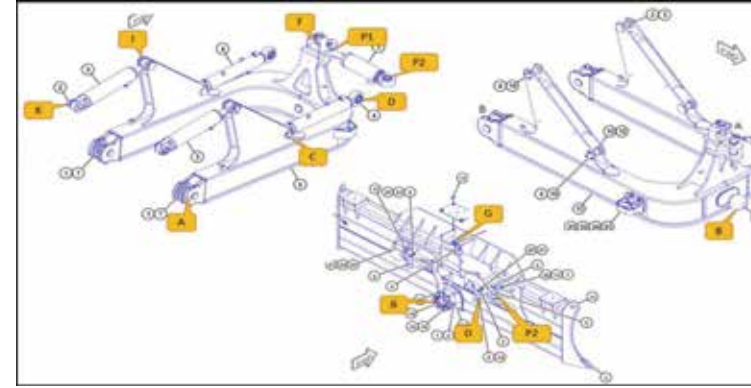
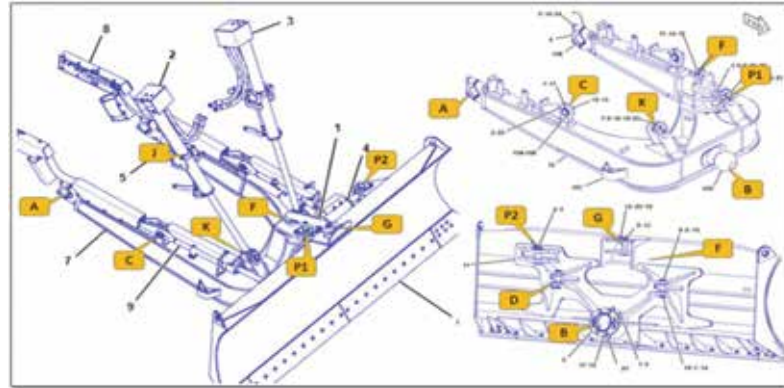
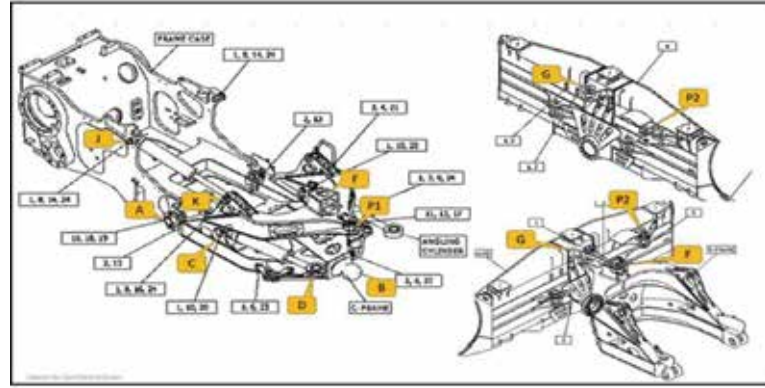

## LINKAGE PIN - BLADE





Sales Model	Serial Number Prefix	VPAT Vertical Lift Cylinders								Tilt Cylinder - Cylinder End	Tilt Cylinder - Rod End	Link Assembly Frame End	Link Assembly Blade End	Equalizer Bar		
		A	B	C	D	F	G	J	K					P1	P2	P3
D6N	DJY, DJA, JAH	(Quantity 2) 109-0958 Pin	-	(Quantity 2) 124-5741 Pin	(Quantity 2) 3G-8932 Pin	-	-	(Quantity 2) 124-5233 Pin	(Quantity 2) 3G-8932 Pin	160-5691 Pin	104-4817 Pin	104-4817 Pin	104-4817 Pin	109-0367 Pin	(Quantity 2) 340-7503 Pin	
	LJR, GHS, MLW		342-8909 Trunnion	(Quantity 2) 358-2191 Pin	(Quantity 2) 358-2227 Pin	245-1168 Pin	358-2227 Pin	(Quantity 2) 124-5741 Pin		104-4817 Pin						160-5691 Pin
	PER, PBA			(Quantity 2) 124-5741 Pin	(Quantity 2) 3G-8932 Pin					473-4512 Pin						104-4817 Pin

## BEARINGS AND BUSHINGS - BLADE

Sales Model	Serial Number Prefix	VPAT Vertical Lift Cylinders								Tilt Cylinder - Cylinder End	Tilt Cylinder - Rod End	Link Assembly Frame End	Link Assembly Blade End	Equalizer Bar	
		A	B	C	D	F	G	J	K					P1	P2
D6N	DJY, DJA, JAH	-	-	(Quantity 2) 4D-4431 Bearing	(Quantity 2) 4D-4431 Bearing	-	-	(Quantity 2) 6E-5449 Bushing	(Quantity 2) 6E-5449 Bushing	7J-1309 Bushing	160-0305 Bearing	7J-1309 Bushing	7J-1309 Bushing	(Quantity 2) 7P-6596 Bushing	(Quantity 2) 8G-4189 Bearing
	LJR, GHS, MLW	(Quantity 2) 107-8126 Bearing	(Quantity 2) 383-3364 Bearing Cap	(Quantity 2) 4D-4431 Bearing	(Quantity 2) 4D-4431 Bearing	8T-0333 Bearing	8T-0333 Bearing				160-0305 Bearing	7J-1309 Bearing	7J-1309 Bearing		
		(Quantity 2) 145-0804 Bearing Sleeve	(Quantity 2) 490-1616 Bearing Cap	(Quantity 2) 237-4860 Bearing	(Quantity 2) 237-4860 Bearing						7J-1309 Bushing				
PER, PBA	Quantity (2) 107-8126 Bearing	456-9700 Bearing (Quantity 2) 490-1616 Bearing Cap	(Quantity 2) 237-4860 Bearing	(Quantity 2) 237-4860 Bearing	7J-1309 Bushing	-	-	7P-6596 Bushing 8G-8311 Bushing							

# D6N XL VPAT Blades

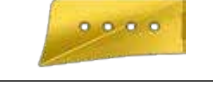
Blade Serial Numbers: 3WP, 3XP, 5A5, AA9, B6X, G6M, G6N

End Bits and Cutting Edges 8" (203 mm)											
Type		End Bits				Edges				Notes	
		Thickness	End Bits	Hardware	Position	Thickness	Edges	Quantity	Hardware		
	Level Cut	19" (482 mm)	8E-9379 8E-9378	4 4	Right Left	19" (482 mm)	3G-4282	2	7	Equipped from factory GP: 8E-9380	
		25" (635 mm)	323-4279 323-4280	4 4	Right Left	-	-	-	-		
	Level Cut Reversible	19" (482 mm)	3G-4285 (2 req'd)	4	Right Left	19" (482 mm)	3G-4282	2	7	GP: 3G-4210	
	GP (HC)	22" (559 mm)	140-6787 140-6788	4 4	Right Left	19" (482 mm)	3G-4282	2	7	GP: 507-2847	
Specialty											
	Performance End Bits	24" (609 mm)	462-4828 462-4829	4 4	Right Left	19" (482 mm)	3G-4282	2	7	GP: 522-4007	
	A.R.M. <sup>1</sup>	19" (482 mm)	473-9970 473-9971	4 4	Right Left	-	-	-	-	-	
Hardware, Repair Parts and Wear Protection											
Type	Description	Part Number	Quantity	Notes							
Hardware	Bolts	3/4-10 x 2-1/2	5J-4773	22	Ensure Base Edge is flat and not excessively worn Clean and remove any paint on mating surfaces Torque, Bang, Torque						
	Nuts	3/4-10	2J-3506	22							
	Washers	-	5P-8248	22							
Blade Repair	Edge Support	-	8E-9502	1	-						

<sup>1</sup>Traditional Design





# D6N XL VPAT Foldable Blades

End Bits and Cutting Edges 8" (203 mm)											
Type		End Bits				Edges				Notes	
		Thickness	End Bits	Hardware	Position	Thickness	Edges	Quantity	Hardware		
	Level Cut	19" (482 mm)	8E-9379	4	Right	19" (482 mm)	3G-4282 257-0264 257-0265	1 1 1	7 5 6	Equipped from factory GP: 257-0207	
Hardware, Repair Parts and Wear Protection											
Type	Description	Part Number	Quantity	Notes							
Hardware	Bolts	3/4-10 x 2-1/2	5J-4773	22	Ensure Base Edge is flat and not excessively worn Clean and remove any paint on mating surfaces Torque, Bang, Torque						
	Nuts	3/4-10	2J-3506	22							
	Washers	3/4"	5P-8248	22							
Blade Repair	Edge Support	-	257-0215 257-0232	1 1	-						

# D6N XL SU Blades

Blade Serial Numbers: 2SP, 6GP, CZ7, ECA, SGD, SS5, TR5

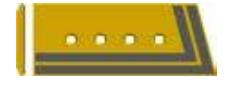



End Bits and Cutting Edges 8" (203 mm)											
Type		End Bits				Edges				Notes	
		Thickness	End Bits	Hardware	Position	Thickness	Edges	Quantity	Hardware		
	Level Cut	19" (482 mm)	8E-9379 8E-9378	4 4	Right Left	19" (482 mm)	9U-8057 4T-6659	2 1	4 7	Equipped from factory GP: 9U-8079	
		25" (635 mm)	323-4279 323-4280	4 4	Right Left	19" (482 mm)	9U-8057 4T-6659	2 1	4 7		
	Level Cut Reversible	19" (482 mm)	3G-4285 (2 req'd)	4	Right Left	19" (482 mm)	9U-8057 4T-6659	2 1	4 7	GP: 507-2849	
	GP (HC)	22" (559 mm)	140-6787 140-6788	4 4	Right Left	19" (482 mm)	9U-8057 4T-6659	2 1	4 7	GP: 507-2850	
Specialty											
	A.R.M. <sup>1</sup>	19" (482 mm)	473-9970 473-9971	4 4	Right Left	-	-	-	-	-	
Hardware, Repair Parts and Wear Protection											
Type	Description	Part Number	Quantity	Notes							
Hardware	Bolts	3/4-10 x 2-1/2	5J-4773	23	Ensure Base Edge is flat and not excessively worn Clean and remove any paint on mating surfaces Torque, Bang, Torque						
	Nuts	3/4-10	2J-3506	23							
	Washers	3/4"	5P-8248	23							
Blade Repair	Edge Support	-	9U-8440 9U-8439	2 1	-						

<sup>1</sup>Traditional Design



# D6N LGP VPAT Blades

Blade Serial Numbers: 4MP, 5A7, AA3, FLM, B6L, G6G

End Bits and Cutting Edges 8" (203 mm)											
Type	End Bits				Edges				Notes		
	Thickness	End Bits	Hardware	Position	Thickness	Edges	Quantity	Hardware			
	Level Cut	19" (482 mm)	8E-9379 8E-9378	4 4	Right Left	19" (482 mm)	4T-2315	2	10	Equipped from factory GP: 4T-2314	
		25" (635 mm)	323-4279 323-4280	4 4	Right Left	25" (635 mm)	327-7911	2	10	—	
	Level Cut Reversible	19" (482 mm)	3G-4285 (2 req'd)	4	Right Left	19" (482 mm)	4T-2315	2	10	GP: 507-2852	
	GP (HC)	22" (559 mm)	140-6787 140-6788	4 4	Right Left	19" (482 mm)	4T-2315	2	10	GP: 507-2853	
Specialty											
	Performance End Bits	24" (609 mm)	462-4828 462-4829	4 4	Right Left	19" (482 mm)	4T-2315	2	10	GP: 522-4009	
	A.R.M. <sup>1</sup>	19" (482 mm)	473-9970 473-9971	4 4	Right Left	—	—	—	—	—	
Hardware, Repair Parts and Wear Protection											
Type	Description	Part Number	Quantity	Notes							
Hardware	Bolts	3/4-10 x 2-1/2	5J-4773	28	Ensure Base Edge is flat and not excessively worn Clean and remove any paint on mating surfaces Torque, Bang, Torque						
	Nuts	3/4-10	2J-3506	28							
	Washers	3/4"	5P-8248	28							
Blade Repair	Edge Support	—	112-7615	1	—						

<sup>1</sup>Traditional Design

# D6N XL VPAT Foldable Blades

End Bits and Cutting Edges 8" (203 mm)											
Type	End Bits				Edges				Notes		
	Thickness	End Bits	Hardware	Position	Thickness	Edges	Quantity	Hardware			
	Level Cut	19" (482 mm)	8E-9379 8E-9378	4 4	Right Left	19" (482 mm)	278-2168 278-2169 278-2170	2 1 1	4 6 6	257-8150 (as equipped from factory)	
Hardware, Repair Parts and Wear Protection											
Type	Description	Part Number	Quantity	Notes							
Hardware	Bolts	3/4-10 x 2-1/2	5J-4773	28	Ensure Base Edge is flat and not excessively worn Clean and remove any paint on mating surfaces Torque, Bang, Torque						
	Nuts	3/4-10	2J-3506	28							
	Washers	3/4"	5P-8248	28							
Blade Repair	Edge Support	—	456-9686 257-8118	1 1	—						

# Ripper Shanks

Shank Size	Type	Assembled Length	Part Number	Field Repair		Tip Size
				Adapter	Nose	
73mm x 176mm	Straight	711mm	484-8282	—	8E-7350	R350 CR350
	Curved	667mm	9J-8923*			

\*No accommodations for Shank Protector (MS) - Multi Shank (SS) - Single Shank (DR) - Deep Rip (LP) - Leach Pad

# Ripper Tips

Machine Model	Tip Size	Type	Style	Tips		Hardware	
				Intermediate	Pin	Pin	Qty
D5R, D5R2, D6G, D6M, D6N, D6R, D6R2, D6T	R350 CR350	R350 Pin-on	Centerline	6Y-0352	Pin Retainer	114-0358 114-0359	1 1
			A.R.M.	159-0355			
			Penetration	6Y-0359			
			A.R.M.	159-0356			
D7R, D7E	R350 CR350	CR350 CapSure	Centerline	472-0824	Pin	473-3816	1
			Penetration	472-0825			

# Shank Protectors

Shank Width	Type	Standard	Sharp	Hardware		Qty
75mm	Pin-on	138-0796	—	Pin Retainer	114-0358	1
				Pin Retainer	114-0359	1
	CapSure	—	472-0827	—	473-3816	1



## CAB

Description	Prefix	Standard
Glass, Door - Right	DJA, DJY, GHS, JAH, LJR, MLW, PBA, PER	167-1452
Glass, Door - Left	DJA, DJY, GHS, JAH, LJR, MLW, PBA, PER	167-1454
Glass (Front)	DJA, DJY, GHS, JAH, LJR, MLW, PBA, PER	365-8937
Glass (Rear)	DJA, DJY, GHS, JAH, LJR, MLW, PBA, PER	170-2070
Glass, Fixed Side (Left)	DJA, DJY, GHS, JAH, LJR, MLW, PBA, PER	203-7738
Glass, Fixed Side (Right)	DJA, DJY, GHS, JAH, LJR, MLW, PBA, PER	203-7741
Glass, Sliding Side (Left)	DJA, DJY, GHS, JAH, LJR, MLW, PBA, PER	203-7740
Glass, Sliding Side (Right)	DJA, DJY, GHS, JAH, LJR, MLW, PBA, PER	203-7742
Radio - AM/FM	DJA, DJY, GHS, JAH, LJR, MLW, PBA, PER	450-5739
Radio Antenna	DJA, DJY, GHS, JAH, LJR, MLW, PBA, PER	6C-3431

## MIRRORS AND LIGHTS

Description	Prefix	Part Number
Flood Lamp (Suspended)	DJA, DJY, GHS, JAH, LJR, MLW, PBA, PER	225-5075
Flood Lamp - Open Cab	DJA, DJY, GHS, JAH, LJR, MLW	243-4799
Flood Lamp - Enclosed Cab	DJA, DJY, GHS, JAH, LJR, MLW	301-7805
Warning Beacon	DJA, DJY, GHS, JAH, LJR, MLW, PBA, PER	302-4254
Rearview Mirror	DJA, DJY, GHS, JAH, LJR, MLW, PBA, PER	8E-8706

## OTHER MISCELLANEOUS

Description	Prefix	Part Number
Fuel Cap	DJA, DJY, GHS, JAH, LJR, MLW, PBA, PER	349-7059





# Cat Filters Provide Longer Injector Life

Chances are, you don't skip oil changes or regular maintenance on the family car. So why skip planned maintenance on your Cat equipment? Cat fuel filters outperform the competition, with up to 45% longer injector life and up to 80% decreased cost per hour.\*



# Productivity and Hydraulics Go Hand In Hand

If your hydraulic system isn't performing at peak efficiency, it's robbing your machine of performance. Efficiency losses usually occur slowly and can reach 20% before you detect a problem — that's one day of lost production every week! These losses can also increase your fuel consumption and operating costs.



# Need help?

Your local Cat dealer can provide:

- Technical Support
- Customer Value Agreements
- Oil sample analysis
- Parts needed and equipment fit
- Repair financing
- Rental Services

Find your local dealer at [www.cat.com](http://www.cat.com) today.



To buy Cat parts online, visit [Parts.cat.com](http://Parts.cat.com).

# LET'S DO THE WORK.™

\* Visit <https://www.cat.com/filtersandfluids> for more details

PEBJ0173-01  
(N Am, EAME, Aus/NZ, CIS, Japan, LACD)

© 2023 Caterpillar. All Rights Reserved. CAT, CATERPILLAR, LET'S DO THE WORK, their respective logos, "Caterpillar Corporate Corporate Yellow", the "Power Edge" and Cat "Modern Hex" trade dress as well as corporate and product identity used herein, are trademarks of Caterpillar and may not be used without permission.

