

# 2021E

Wheel Loader

# HINDUSTAN



IMPROVED  
OPERATOR ENVIRONMENT



HIGHLY RELIABLE & FUEL  
EFFICIENT BS IV ENGINE

**Bestseller**  
Got  
**Cleaner**

BS IV  
EMISSION COMPLIANT



HIGHER PRODUCTIVITY WITH  
BEST LIFT HEIGHT



LOWEST OWNING &  
OPERATING COST

## 2021E

<b>Engine Model*</b>	ASHOK LEYLAND, H6C413323
<b>Rated power (gross)</b>	98 kW (133hp) @ 2300 RPM
<b>Bucket Capacity</b>	1.53 - 3.0 m <sup>3</sup>
<b>Payload</b>	3,210 kg
<b>Operating Weight</b>	11,700 kg

\*Engine meets BHARAT STAGE IV (CEV) emission standards

## Bestseller Got Cleaner

The 2021E Wheel Loaders set the standard for productivity, fuel efficiency and operator comfort. The improved optimized Z-bar loader linkage delivers the quick loading performance of a traditional Z-bar with the parallelism and load handling capability of a tool carrier. 2021E will continue to have the best lift height in its class with industry best dump clearance and it will be offered as a standard feature.

### Efficiently Powerful

Experience better fuel efficiency with an optimized power train. The new **Ashok Leyland** turbo charged engine has better structural strength and comes with common rail fuel injection system for better fuel efficiency, engine life and reduction in exhaust emission gas levels.

The new Electronic Control Module (ECM) controlled Engine monitors the status of all the Engine functions thereby enhancing the fuel efficiency and Improved exhaust emissions levels. The ECM controlled engine also helps in maintenance and troubleshooting of all Engine components reducing downtime during servicing and increasing your productivity.

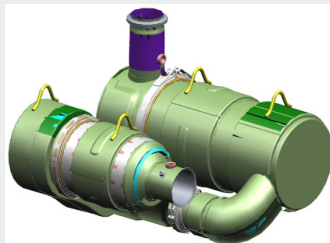
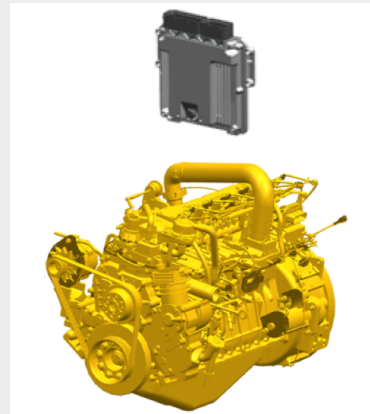

### Engine After Treatment

After treatment (DOC+SCR) unit installed in the machine reduces harmful exhaust emissions from the internal-combustion engine. This will ensure clean exhaust gas to meet the BS IV emission requirement for this machine.

After treatment fluid tank is provided to fill Diesel Exhaust Fluid. Consumption rate is optimized and Diesel Exhaust Fluid level can be viewed in the display cluster for refilling.

### Enjoy All Day Comfort

Have a seat in the 2021E Wheel Loader and enjoy, low sound levels, all around Visibility and smooth joystick controls. Custom designed seat with wrap around Lumbar Support and reclining backrest for operator rest periods. The spacious cab and wide platform at the top make the transition from cab to ground easy, safe and comfortable. The controls and displays have been designed to be adjustable and within reach of all sizes of operators. Ergonomically placed grab rails, handles and footsteps allow the operator to have three point contact for safe Entry and Exit from the machine. Two Rear Working Lights add to better visibility in Low Light conditions and Night operations. One internal and two external rear view mirrors enhance rear visibility.



### Configured for Success

A complete range of optional equipment gives the versatility to configure the Hindustan 2021E Wheel Loader to make you successful in your business.

Among the multiple factors that help reduce fuel consumption and operating costs are the Caterpillar patented Performance Series buckets. Performance buckets utilize a system approach that balances bucket shape, linkage design, weight, lift and tilt capacity. The results are improved bucket load ability, higher fill factor, better material retention and shorter loading time. Higher Lift arm provides easier and faster truck and wagon loading.



### Product Link™

Product Link™ wirelessly connects you to your equipment giving you valuable insights into how your machine or fleet is performing. Information such as Location, Hours worked, Productivity, Geofence are made available through online web application so that you can make timely, fact-based decisions to maximize efficiency, improve productivity along with the power of 4G connectivity.



## Engine

Make	Ashok Leyland
Model	H6C413323
Type	4 Stroke, 6 Cylinder
Bore & Stroke	104 X 113 mm
Displacement	5.76 Litre
Gross Power	98 kW (133 hp) @ 2300 rpm
Max Torque	475 Nm @ 1700 - 1900 rpm
Aspiration	Turbocharged
Emission	Bharat Stage IV ( CEV )

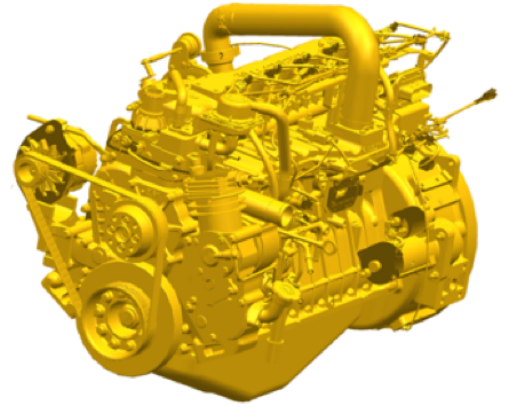

## Transmission

- Proven durable 4 wheel drive powershift transmission with mechanically actuated hydraulic control. Build with 2 phase, 4 element twin turbine torque converter.

Vehicle Speeds	Kmph
Forward 1	
Low Turbine	3.2
High Turbine	7.0
Forward 2	
Low Turbine	12.3
High Turbine	25.8
Reverse 1	
Low Turbine	4.4
High Turbine	9.5

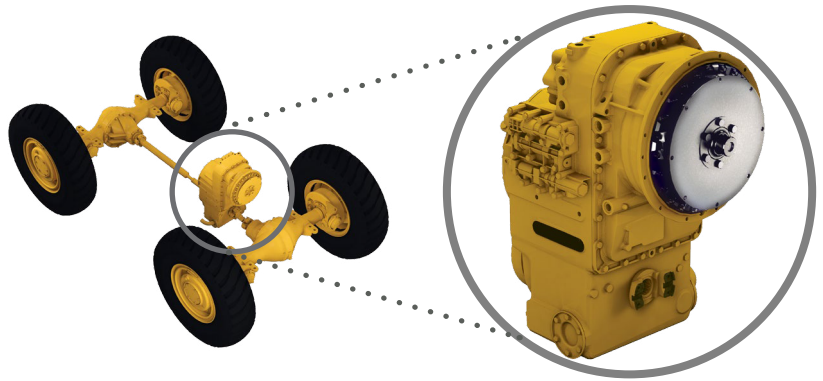

## Drive Axles

- Front Axle fixed and Rear Axle oscillates at  $\pm 11^\circ$ . Conventional Heavy duty differential. Full floating axle shaft can be removed independently off wheel and planetary

## Brakes

Service Brakes	Four Wheel air actuated brakes with separate circuit for front & rear axles.
Parking Brake	Hand operated, mechanically expanding shoe brake mounted at transmission output shaft.
Emergency Brake	Uses Service brake. When air pressure drops below 45psi, an audible warning horn sound and brakes are applied automatically. Operator can also manually apply the brakes.

## Tires

- Rims are bolted directly to the wheels for positive non slip retention.

Standard Tire	14.00 X 25 - 20PR E3/L3
---------------	-------------------------

## Steering

- Steering system uses a load sensing with integrated priority valve operating at 155 bar to provide low effort and smooth response.

Steering articulation angle each direction	$\pm 40^\circ$
--	----------------



## Loader Hydraulic System

- Tandem Gear Pump. Two double acting lift cylinder and one double acting tilt cylinder. Two Spool hydraulic control valve. Standard machine comes with single joystick operated hydraulics with hand rest.

Pump Flow @ 2530 RPM	196 LPM
Hydraulic Cycle Time @ 2530 RPM	
Lift	Max 5.5 Seconds
Lower	Max 4 Seconds
Tilt Back	Max 3 Seconds
Dump	Max 2 Seconds
Float	Max 4 Seconds



## Cab

**The Cab has** - headliner, internal cab light, fan, floor mat, front wiper, rear wiper (optional) with aesthetic cover, safety (emergency) hammer, sound & heat suppression, internal & external mirrors. Aesthetic non-metallic consoles in cab, mobile charger power socket, cup and bottle holder for water bottle, coffee mug. Easily removable, aesthetically designed, Cab covers (skirts) for better access to machine repair and maintenance points. Improved Comfort Seat, with wrap around lumbar back support, cushion and arm rest. Improved visibility from cab with one internal & two external mirrors. Operator controls with Pilot Operated Hydraulic joystick, placed ergonomically beside the Operator seat. Guards for the windshield comes as standard. Air Conditioning and heating (HVAC) is available for Cab as option.



## Electrical System

- Entire machine electrical system is protected with Main fuse as a safety from Positive side of the battery. System includes 55A or 85A alternator with automatic voltage regulator and 24V system with 2 x 12V 130 ampere-hour batteries. Negative terminal of master switch is grounded ensuring complete electrical circuit is open during switch off position.

## Bucket

- Performance Series Buckets utilize a long floor and open throat resulting in easy loading and good material retention.

General Purpose (GP)	1.7 & 2.0 m <sup>3</sup>
Light Material (LM)	2.5 & 3.0 m <sup>3</sup>
Rock (RK)	1.53 & 1.7 m <sup>3</sup>



## Service Refill Capacities

	Litre
Fuel Tank	181
Diesel Exhaust Fluid (DEF) Tank	24
Cooling System	23
Engine crankcase	15
Transmission	41
Axles (Diff. & Planetary)	
Front	20
Rear	20
Hydraulic system (including tank)	127
Hydraulic tank	90



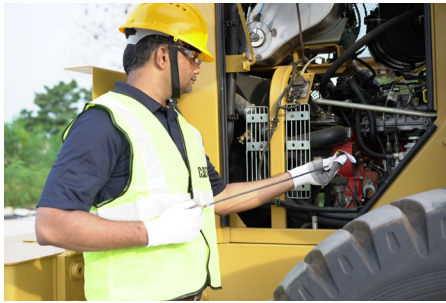

## Work Made Easy with Lower Operating Costs

Move more with quick loading Performance Series buckets and optimized Z-bar linkage that significantly improve productivity. You will experience high fill factors and reduced fuel consumption per unit of material handled. Optimized steering hydraulics and less wheel turns significantly reduce operator effort. Optimized Structures with best lift height suits well to the most common truck and wagon sizes which facilitates faster & easier loading. Performance Series Buckets provide better fill factors and material retention.

This will **significantly lower fuel consumption per unit of material handled**. Best in Class design of fluid filtration integrated circuits results in extended service intervals. The implement joystick is designed as single lever, which provides smooth and efficient control of the machine during hydraulic application. Large mechanical doors provide excellent access for daily inspection of engine and cooling system components. Conveniently located hand operated Parking Brakes add to safety.

All dimensions are approximate. Dimensions will vary with bucket and tire choice. Refer to Operating Specifications with Buckets

**1	Height: ground to cab	3207 mm
**2	Height: ground to exhaust stack	2470 mm
**3	Height: ground to axle center	634 mm
**4	Height: ground clearance	367 mm
*5	Length: overall	7034 mm
6	Length: rear axle to bumper	1907 mm
7	Height: Ground to hood	2163 mm
8	Length: wheel base	2658 mm
*9	Clearance: bucket at 45°	2936 mm
**10	Clearance: load over height	3453 mm
**11	Clearance: level bucket	3553 mm
**12	Height: bucket pin	3828 mm
**13	Height: overall	4893 mm
*14	Reach: bucket at 45°	1157 mm
15	Carry height: bucket pin	460 mm
**16	Dig depth	102 mm
17	Width: bucket	2550 mm
18	Width: tread center	1976 mm
19	Turning radius: over bucket	5598 mm
20	Width: over tires	2362 mm
21	Turning radius: outside of tires	4970 mm
22	Turning radius: inside of tires	2365 mm
23	Rack angle at full lift	58°
24	Dump angle at full lift	50°
25	Rack angle at carry	50°
26	Departure angle	27°
27	Articulation angle	40°
	Operating weight	11700kg

\* Vary with bucket  
\*\* Vary with tire

Dimensions listed are for a machine configured with 1.8 cu.m general purpose pin on bucket, bolt- on cutting edge (BOCE), standard counterweights, 80kg (176lb) operator and 14.00 x 25 – 20PR E3/L3.

## Dimensions with Bucket

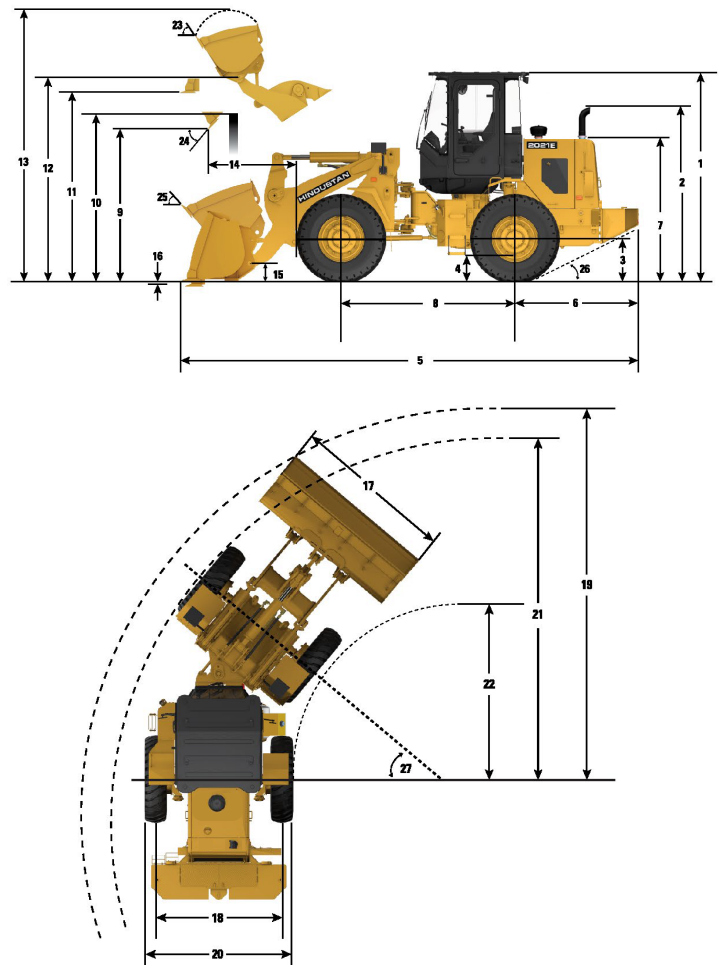

## 2021E Operating Specifications with Buckets

		General Purpose			Light Material				Rock	
Rated capacity	m <sup>3</sup>	1.8	1.7	2	2.6	2.5	3.1	3	1.53	1.7
Struck capacity	m <sup>3</sup>	1.5	1.4	1.6	2.2	2.1	2.6	2.5	1.31	1.5
Width: bucket	mm	2550	2550	2700	2800	2800	2800	2800	2550	2550
Payload	kg	3210	3255	3200	3060	3115	3295	3340	3165	3165
Nominal material density, 100% fill factor	kg/m <sup>3</sup>	1654	1744	1506	1100	1158	996	1043	1850	1640
Clearance: full lift, 45° dump	mm	2936	2879	2828	2787	2727	2709	2648	2736	2736
Reach: full lift, 45° dump	mm	1157	1263	1299	1275	1380	1345	1449	1426	1426
Reach: 2130 mm (7'0") clearance, 45° dump	mm	1314	1776	1389	1417	1817	1473	1841	1868	1868
Reach: level arm, level bucket	mm	2345	2463	2527	2541	2659	2647	2765	2680	2680
Dig depth	mm	102	77	77	102	77	102	77	82	82
Length: overall	mm	7034	7133	7197	7230	7329	7336	7435	7354	7354
Height: overall	mm	4893	4893	4915	5045	5045	5209	5209	4719	4848
Turning radius, bucket at carry	mm	5598	5623	5708	5765	5790	5795	5821	5687	5687
Tipping load- straight	kg	7809	7907	7796	7495	7607	8092	8167	7713	7718
Tipping load- full turn	kg	6423	6512	6409	6128	6232	6592	6681	6338	6337
Breakout force	kg	10379	11122	10329	8918	8979	7654	8096	8900	8877
Operating weight	kg	11543	11506	11569	11736	11686	12226	12176	11550	11586
Ground engaging tool		BOCE	with Teeth	with Teeth	BOCE	with Teeth	BOCE	with Teeth	with Teeth	with Teeth

- Dimensions listed are configured with standard and heavy counterweights, 80 kg (176 lb) operator and 14.00 x 25 - 20PR E3/L3 tires at a recommended pressure of 3.8 bar (55 psi) in the front tires and 3.1 bar (45 psi) in the rear tires.
- Bucket with bolt on cutting edge (BOCE) are shown for technical information purposes only.

## 2021E Bucket Selection Table

% Bucket Fill Factor

Material Density (Kg/m <sup>3</sup> )	1275	1300	1325	1350	1375	1400	1425	1450	1475	1500	1525	1550	1575	1600	1625	1650	1675	1700	1725	1750	1775	1800	1825	1850	1875	1900	1925	1950	1975	2000
Bucket Size																														
1.53 cu.m RK																115%	110%		105%	100%		95%								
1.7 cu.m GP											115%	110%		105%	100%		95%													
1.7 cu.m RK								115%	110%		105%	100%		95%																
2.0 cu.m GP				115%	110%		105%	100%		95%																				

Material Density (Kg/m <sup>3</sup> )	815	830	840	860	875	890	905	920	935	950	965	980	995	1010	1025	1040	1055	1070	1085	1100	1115	1130	1145	1160	1175	1190	1205	1220	1235	1250
Bucket Size																														
2.5 cu.m LM															115%	110%		105%	100%		95%									
3.0 cu.m LM									115%	110%		105%	100%		95%															

All buckets are with weld on teeth

## Material Density Table

Materials	Density
Earth and rock	~ 1800 kg/m <sup>3</sup>
Sand and gravel	~ 1700 kg/m <sup>3</sup>
Aggregates	~ 1600 kg/m <sup>3</sup>
Coal	~ 900-1150 kg/m <sup>3</sup>
Woodchips	~ 500 kg/m <sup>3</sup>

Material density provided here are for reference only. Material density assessment must be carried out for each individual jobsite / application.

## 2021E Standard Equipment

### POWER TRAIN

- Brake/decelerator pedal
- Ashok Leyland H series engine
- BS-IV Compliant engine
- Turbocharged
- Coolant
- Differential front open
- Differential rear open
- Dry type air cleaner
- Brakes : Dual System
- Emergency and Parking Brake System (SAE J1152)
- Fuel priming pump
- Fuel water separator
- Standard hydrodynamic transmission
- Single plane cooling system with coolant reservoir
- Transmission oil cooler
- Tires: Bias ply, 14 x 25

### HYDRAULICS

- Single pilot lever hydraulic control
- Hydraulic cooler
- Hydraulic S.O.S ports
- Hydraulic oil sight gauge, visible
- Load sensing hydraulics and steering

### ELECTRICAL

- 24 volt system
- Batteries- 2 x 12v
- Main Fuse- 100 Amps
- Alternator, 55 Amps or 85 Amps
- Back-up alarm
- Battery disconnect switch
- Directional signals front and rear
- Halogen work lights for rear
- Front Rooding lights

### OPERATOR ENVIRONMENT

- Product Link
- Cab supported on resilient mount
- Hi-vis Seat belt
- Static seat
- Cup holder
- External mirrors (2)
- Interior rear view mirror (1)
- Ground level cab door release
- 12V mobile charger
- Gauges
  - Engine coolant temperature gauge
  - Fuel level indicator gauge
  - Tachometer
- Digital display
  - Digital hour meter
  - Digital brake air pressure gauge
  - Digital Torque converter temp. gauge
  - Digital DEF\* level
  - Digital DEF\* quality level
- Operator warning system indicators (Audio visual)
  - Low engine lube oil pressure
  - Low transmission oil pressure
  - Low brake air pressure
  - High engine coolant temperature
  - High transmission oil temperature
  - Low Fuel level
  - Low DEF\* level
  - Check Engine
  - Emission warning
  - Water in Fuel
  - Battery charging status
  - Turn indicator
  - Hi beam indicator
  - Hazard
  - Loss of signal

- Hydraulic control lockout
- Interior cab lighting at dome
- Removable floor mat
- Sliding glass on the side windows
- Steering column mounted multi function control – lights, wipers, turn signal
- Laminated front glass
- Front wiper, 2-speed
- Guards - Windshield

### OTHER STANDARD EQUIPMENT

- Fenders
- Counterweight, Std
- Large-access enclosure doors
- Toolbox

\*Diesel Exhaust Fluid

## 2021E Optional Equipment

Optional equipment may vary. Consult your Cat dealer for details.

### OPTIONAL EQUIPMENT:

- HVAC
- Additional Counterweights
- Brace GP - Lift Cylinder
- Rear wiper
- Work tools - Buckets

### DEALER FIT KITS

- Payload measurement system
- DGMS kit
  - Fire Suppression
  - Rear View Camera
  - Audio Visual alarm

NOTE: Not all features are available in all regions. See your Cat dealer for more information.



HVAC

**GCPL Network**

- 🏢 Regional Office - 2
- Zonal Office - 8
- Branch / Area Office - 39
- MARC Project - 14
- ▲ Retail Outlet - 39
- Rental & Equipment office - 9
- Facilities - 3
- ★ Parts Fulfillment Centre - 2
- ▲ Overseas subsidiaries - 2



**Gmmco Network**

- 🏢 Corporate Headquarter
- ★ SBU / Regional Office
- Branch Office
- ◆ Area Office
- Retail Office
- ➡ Workshop
- ▲ Repair Facility
- 🏠 Rental Store

**For Northern and Eastern Regions**

Gainwell Comsales Private Limited  
 705, Godrej Waterside, 7th Floor, Tower II  
 Block DP, Sector V, Salt Lake City  
 Kolkata – 700091  
 Phone: +91 33 6644 2000  
 Toll free number : 1 800 419 3356

**For Southern and Western Regions**

Gmmco Ltd.  
 6 GST Road, St. Thomas Mount, Chennai - 600 016  
 Ph : +91 44 3068 6000-6499,  
 Toll free number : 1 800 425 2546.

**HINDUSTAN  
 2021E  
 Wheel Loader**

Caterpillar India Pvt. Ltd  
 Melnallathur Post, Thiruvallur - 602 004,  
 Tamilnadu, India.

© 2021 Caterpillar  
 All rights reserved

Materials and Specifications are subject to change without notice. Featured machines in photos include additional equipment. See your Cat dealer for available options.

CAT, CATERPILLAR, LET'S DO THE WORK, their respective logos, "Caterpillar Corporate Yellow," the "Power Edge" and Cat "Modern Hex" trade dress as well as corporate and product identity used herein, are trademarks of caterpillar and may not be used without permission.