



K SERIES SMALL WHEEL LOADER PARTS REFERENCE GUIDE

BUILT FOR IT.™



PROTECT YOUR INVESTMENT WITH GENUINE CAT® PARTS

Thank you for selecting the Cat® K Series Small Wheel Loader.

This guide is designed to provide you with a quick reference for the parts and part numbers you need to keep your Cat Small Wheel Loader running at peak efficiency.

MAINTENANCE

Proactive preventative maintenance extends the life of your machine and protects your investment. Only Caterpillar knows Cat equipment's filtration and lubrication requirements and offers parts kits to match your machine's maintenance cycles.

SCHEDULED MAINTENANCE PARTS

| | |
|---|---------------------------------|
|  | GREASES |
| | PLANNED MAINTENANCE KITS |

REPLACEMENT PARTS

Proper maintenance minimizes the need for repair and replacement. In the event that replacement parts are required, the use of genuine Cat parts helps maximize machine performance and maintains high resale value.

WEAR PARTS

| | |
|--|-------------------------------------|
|  | COMMON GROUND ENGAGING TOOLS |
|--|-------------------------------------|

MINOR REPAIR PARTS

| | |
|--|----------------------------------|
|  | MIRRORS, LIGHTS AND FUSES |
|--|----------------------------------|

CAB GLASS AND ACCESSORIES

OCCASIONAL REPAIR PARTS

| | |
|--|--------------------------|
|  | BATTERIES |
| | ENGINE PARTS |
| | QUICK DISCONNECTS |

GREASES K Series

| Previous Cat Product Name | STANDARD MAINTENANCE GREASES | | | GREASES FOR UNIQUE APPLICATIONS AND ENVIRONMENTS | | | |
|-------------------------------------|----------------------------------|----------------------------------|------------------------------|--|---|--------------------|--------------|
| | Cat Ultra5 Moly #1 | Cat Ultra5 Moly #2 | Cat Advanced 3 Moly | Cat Arctic Platinum | Cat Desert Gold | Cat Multipurpose | Hammer Paste |
| Current Cat Product Name | Cat Extreme Application Grease 1 | Cat Extreme Application Grease 2 | Cat Prime Application Grease | Cat Extreme Application Grease - Arctic | Cat Extreme Application Grease - Desert | Cat Utility Grease | |
| Grade (NLGI) | 1 | 2 | 2 | 0 | 2 | 2 | 2 |
| Melting point (deg C) | 260 | 260 | 260 | 230 | 280 | 260 | 230 |
| Ambient Temperature (deg C) | -35 to +40 | -30 to +50 | -20 to +40 | -35 to +40 | -30 to +50 | -30 to +40 | -20 to +1100 |
| Base Oil Type | Mineral | Mineral | Mineral | Semi-Synthetic | Mineral | Mineral | Mineral |
| Color | Dark Gray | Dark Gray | Dark Gray | Dark Gray | Dark Gray | Blue | Bronze |
| Cartridge (390 g / 14 oz) | 452-5996 | 452-6001 | 452-6006 | 452-7459 | 452-6016 | 452-6011 | 130-6951 |
| Plastic Pail (5 kg / 11 lb) | - | - | - | - | - | - | 133-8807 |
| Plastic Pail (16 kg / 35 lb) | 452-5999 | 452-6004 | 452-6009 | 452-6020 | 452-6019 | 452-6014 | - |
| Keg (55 kg / 120 lb) | 452-5998 | 452-6003 | 452-6008 | 452-7461 | 452-6018 | 452-6013 | - |
| Drum (180 kg / 400 lb) | 452-5997 | 452-6002 | 452-6007 | 452-7460 | 452-6017 | 452-6012 | - |



PLANNED MAINTENANCE KITS

| Small Wheel Loader | | Every 500 Hours | | | | | | Every 1,000 Hours | | | Every 1,500 Hours | |
|--------------------|----------------------|--------------------------|----------------------|--------------------------|--------------------|-------------------|------------------------------|-------------------|-------------------|-------------------|-----------------------|------------------|
| | | Engine Oil/Filter Change | | Lubricate Machine | Fuel Filter Change | | Alternator Air (if equipped) | Engine Air Filter | | Cabin Air | | Engine Crankcase |
| Sales Model | Serial Number Prefix | Filter Element | Oil Qty (L) DEO-ULS™ | Prime Application Grease | Primary Element | Secondary Element | Foam Element | Primary Element | Secondary Element | Fresh Air Element | Recirculating Element | Breather Element |
| 924K | HJF, ENC, SNZ, KW4 | 462-1171 | 19.5 | 452-6006 | 391-3764 | 360-8960 | 364-8305 | 222-9020 | 222-9021 | 365-7606 | 353-5058 | 273-5711 |
| 930K | EYE, DYB, FRK, P3K | 462-1171 | 19.5 | 452-6006 | 391-3764 | 360-8960 | 364-8305 | 222-9020 | 222-9021 | 365-7606 | 353-5058 | 273-5711 |
| 938K | XXT, HFW, REP, W8K | 462-1171 | 19.5 | 452-6006 | 391-3764 | 360-8960 | 364-8305 | 222-9020 | 222-9021 | 365-7606 | 353-5058 | 273-5711 |

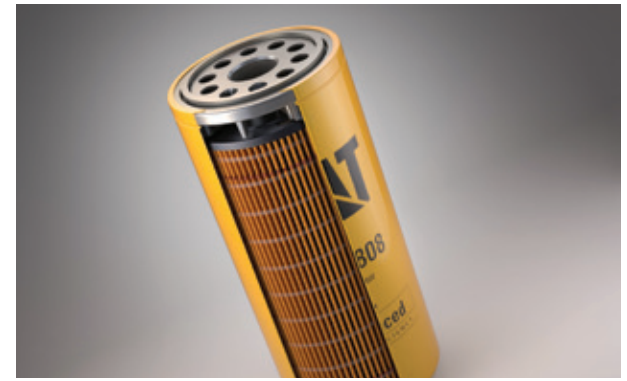

| Small Wheel Loader | | Every 2,000 Hours | | | | | | | | | | | | | |
|--------------------|----------------------|--------------------------|----------|---------|---------------------------|------------|--------|----------------|-------------------------|------------------|-------------|-------------------------------|----------|------------------------------|----------|
| | | Hydraulic Filter Change* | | | Hydraulic Filter Change** | | | Hydraulic Tank | Transmission Oil Change | | | Front Differential Oil Change | | Rear Differential Oil Change | |
| Sales Model | Serial Number Prefix | Filter Element | O-Ring | O-Ring | Filter Element | O-Ring | O-Ring | Breather | Filter Change | Oil Qty (L) TDTO | Seal | Oil Qty (L) | Additive | Oil Qty (L) | Additive |
| 924K | HJF, ENC, SNZ, KW4 | 348-1861 | 095-1671 | 6V-5048 | 421-5481 | (2) 4F4097 | 8C3082 | 258-2829 | 144-6691 | 8.5 | (2) 3K-0360 | 24 (L) TDTO | 1U-9891 | 24 (L) TDTO | 1U-9891 |
| 930K | EYE, DYB, FRK, P3K | 348-1861 | 095-1671 | 6V-5048 | 421-5481 | (2) 4F4097 | 8C3082 | 258-2829 | 144-6691 | 8.5 | (2) 3K-0360 | 27 (L) TDTO | 1U-9891 | 27 (L) TDTO | 1U-9891 |
| 938K | XXT, HFW, REP, W8K | 348-1861 | 095-1671 | 6V-5048 | 421-5481 | (2) 4F4097 | 8C3082 | 258-2829 | 144-6691 | 11 | (2) 3K-0360 | 35 (L) MTO | – | 35 (L) MTO | – |

*Serial number prefix HJF, ENC, EYE, DYB, XXT, HFW **Serial number prefix SNZ, KW4, FRK, P3K, REP, W8K

| Small Wheel Loader | | Every 6,000 Hours | | | Every 12,000 Hours | |
|--------------------|----------------------|------------------------------------|-----|----------------------|----------------------------------|--|
| | | Transmission Oil Change | | | Hydraulic Tank | |
| Sales Model | Serial Number Prefix | Cat Extended Life Coolant Extender | | Hydraulic Oil Change | Cat Extended Life Coolant Change | |
| 924K | HJF, ENC, SNZ, KW4 | 144-6691 | 8.5 | (2) 3K-0360 | 258-2829 | |
| 930K | EYE, DYB, FRK, P3K | 144-6691 | 8.5 | (2) 3K-0360 | 258-2829 | |
| 938K | XXT, HFW, REP, W8K | 144-6691 | 11 | (2) 3K-0360 | 258-2829 | |

All maintenance requirements should be performed at the specified intervals, even when it aligns with another maintenance cycle. At 12,000 hours, maintenance cycles from 6,000 hours, 2,000 hours, 1,500 hours, 1,000 hours and 500 hours should also be addressed.



COMMON GROUND ENGAGING TOOLS K Series

| Tips | J250 | Tips | J250 |
|---------------------|-----------------|---|------------------|
| General Duty (Long) | 1U-3252 | Adapter (RH) | 6I-9251 |
| Penetration | 9J-4259 | 8 x 3 inch Bolts | 4F-4042 (QTY 2) |
| Heavy Abrasion | 9N-4253 | 8 x 3.25 inch Bolts | 4J-9058 (QTY 2) |
| Heavy Duty | 9N-4252 | 8 x 3.75 inch Bolts | 8J-2928 (QTY 12) |
| Wide | 208-5254 | Nuts (Full) | 2J-3507 (QTY 4) |
| Sharp Corner | 9W-8258 | Nuts | 8J-2933 (QTY 12) |
| Sharp Center | 9W-8259 | Set of 8 Bolt-on Adapters (Includes Hardware) | 116-9713 |
| Twin Sharp | 135-8258 | Set of 8 Long Tips (Does Not Include Hardware) | 9W-8142 |
| Short | 1U-3251 | Set of 8 Short Tips (Does not Include Hardware) | 9W-8143 |
| Pin | 132-4763 | Corner Guard (RH)* | 253-0060 |
| Retainer | 149-5733 | Corner Guard (LH)* | 253-0061 |
| Adapter (CTR) | 1U-0257 (QTY 6) | Bolt | 4F-4042 |
| Adapter (LH) | 6I-9250 | Nut | 2J-3507 |

*Not for Light Material Buckets

| Cutting Edges | Bucket Width | | |
|--|------------------------------------|------------------------------------|------------------|
| | 2550 mm | 2750 mm | 3060 mm |
| Standard 4 Piece Cutting Edge | | | |
| Standard | 8E-4567 (QTY 2) | 110-4711 (QTY 2) | 1U-0593 (QTY 2) |
| End | 4T-8091 (QTY 2) | 4T-8092 (QTY 2) | 3G-6395 (QTY 2) |
| 4 Piece Bolt-On Edge (Includes Standard and End Edges) | 8E-4566 | 345-2758 | 371-2342 |
| Standard 3 Piece Cutting Edge | | | |
| Standard | 472-1465 | 472-1468 | 472-1471 |
| Segmented Cutting Edge (For Use with Adapters and Tips) | | | |
| Segmented | 8E-4569 (QTY 7) | 4T-6695 (QTY 7) | - |
| Abrasion Resistant Material (For Use in Abrasive Materials) | | | |
| ARM (RH) | 135-6728 | 123-9195 | 123-0336 |
| ARM (LH) | 135-6729 | 123-9196 | 123-0337 |
| ARM (RH End) | 9W-3481 | 9W-3481 | 9W-3477 |
| ARM (LH End) | 9W-3482 | 9W-3482 | 9W-3478 |
| Hardware (For Use with All Cutting Edges) | | | |
| Bolts | 1J-5607 (QTY 10, 14 for Segmented) | 1J-5607 (QTY 10, 14 for Segmented) | 5P-8823 (QTY 12) |
| Nuts | 2J-3507 (QTY 10, 14 for Segmented) | 2J-3507 (QTY 10, 14 for Segmented) | 3K-9770 (QTY 12) |
| Rubber Edge | | | |
| 2 Piece Bolt-On Rubber Edge | 251-5418 | 444-1522 | 398-6760 |

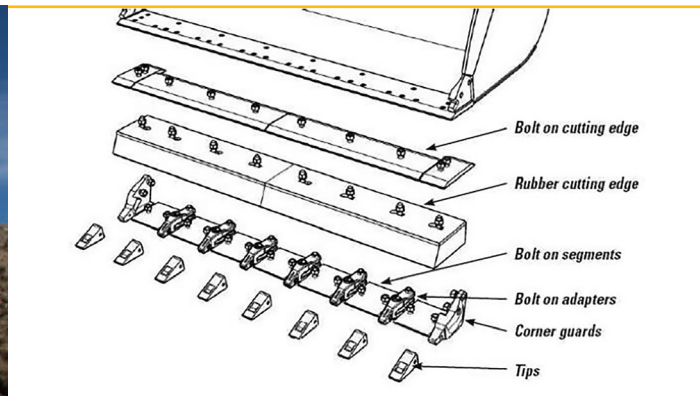

MIRRORS, LIGHTS AND FUSES K Series

| Serial Number Prefix | Description | Part Number | Quantity |
|------------------------------|--------------------------------|-------------|----------|
| HJF, ENC, EYE, DYB, XXT, HFW | Mirror (Heated) | 423-7209 | 2 |
| | Mirror (Heated and Adjustable) | 423-7214 | 2 |
| SNZ, KW4, FRK, P3K, REP, W8K | Mirror (Heated) | 351-9089 | 2 |
| | Mirror (Heated and Adjustable) | 366-7806 | 2 |
| All | Mirror (Interior) | 275-5588 | 2 |

| Lights | Part Number | Quantity |
|--|-------------|----------|
| Lamp 12V (Dome) | 259-1286 | 1 |
| Dome Light Assembly (Standard) | 107-6032 | 2 |
| Dome Light Assembly (LED) | 347-0794 | 2 |
| Rear Bezel Light (Complete) | 325-4471 | 2 |
| Rear Bezel (Lamp Only) | 351-9918 | 2 |
| Flood Lamp Cab (Front and Rear) | 339-3505 | 4 |
| Flood Lamp Cab (Lamp Only) | 351-9918 | 4 |
| Flood Lamp Cab (HID Front Complete) | 324-3740 | 2 |
| Flood Lamp Cab (HID Front Lamp Only) | 290-8160 | 2 |
| Auxiliary Work Light (Front LED)* | 424-5603 | 2 |
| Auxiliary Work Light (Rear LED)* | 426-5380 | 2 |
| Head Lamp (Right Complete) | 344-3455 | 1 |
| Head Lamp (Left Complete) | 344-3456 | 1 |
| Head Lamp Dipped (Right Complete) | 344-3457 | 1 |
| Head Lamp Dipped (Left Complete) | 344-3458 | 1 |
| Head Lamp Component (High/Low Beam Lamp Only) | 9X-3465 | 2 |
| Head Lamp Component (Flood Lamp Only) | 130-3515 | 2 |
| Head Lamp Component (Turn Signal Lamp Only) | 242-0588 | 2 |
| Head Lamp Component (Headlight Lens Only) | 444-6523 | 2 |
| Head Lamp Component (Turn Signal Left/Right Lens Only) | 228-6052 | 2 |

*Not applicable for serial number prefix HJF, ENC, EYE, DYB, XXT, HFW

| Fuses | Part Number |
|-------------|-------------|
| 10 amp Mini | 113-8490 |
| 15 amp Mini | 113-8491 |
| 20 amp Mini | 113-8492 |
| 30 amp Mini | 124-3548 |

CAB GLASS AND ACCESSORIES K Series

| Description | Part Number |
|-----------------------------|-------------|
| Wiper Blade (Front) | 189-8610 |
| Wiper Blade (Rear) | 8Y-4615 |
| Windshield (Main) | 341-9901 |
| Windshield (Bottom RH) | 371-7926 |
| Windshield (Bottom LH) | 371-7925 |
| Glass (LH Side) | 341-9902 |
| Door Glass (Lower) | 341-9754 |
| Door Window (Assembly) | 341-9755 |
| Door Window (Upper Fixed) | 341-9793 |
| Door Window (Upper Sliding) | 341-9794 |
| Door Window (Lower Fixed) | 341-9795 |
| Window Assembly (RH Side) | 341-9725 |

| Description | Part Number |
|--------------------------|-------------|
| Window Sliding (RH Side) | 341-9731 |
| Window Fixed (RH Side) | 341-9730 |
| Rear Glass | 341-9903 |
| Seat Belt (2"/3") | 241-6149 |
| Cab Grab Handle | 341-9742 |
| Washer Bottle Cover | 366-8189 |
| Decal for Cover | 360-1858 |
| Ladder Plate (LH) | 339-6744 |
| Ladder Plate (RH) | 339-6749 |
| Individual Ladder Steps | 308-6660 |
| Ladder Mounting Bracket | 339-6745 |

BATTERIES K Series

| Description | Part Number | Quantity |
|-------------|-------------|----------|
| Standard | 115-2422 | 2 |
| Heavy Duty | 115-2422 | 4 |



ENGINE PARTS K Series

| Description | Part Number | Quantity |
|--|-------------|----------|
| Engine Belt | 350-8742 | 1 |
| Alternator Assembly (115 amp) | 344-5081 | 1 |
| Alternator Assembly (150 amp) | 272-1889 | 1 |
| Fuel Injector Assembly | 371-3974 | 6 |
| Fuel Injection Pump Assembly | 375-2647 | 1 |
| Water Pump Assembly | 485-4895 | 1 |
| Starter Motor | 354-5671 | 1 |
| Turbocharger Group | 315-9810 | 1 |
| Thermostat – Engine Coolant with Integrated Gasket | 417-7782 | 1 |
| Thermostat – Gasket | 281-8744 | 1 |

QUICK DISCONNECTS K Series

| Description | Part Number |
|---|-------------|
| Quick Disconnect Coupling – Male* | 241-6189 |
| Quick Disconnect Coupling – Female* | 241-6190 |
| Conversion Kit to Twist to Connect* | 441-4005 |
| Quick Disconnect Coupling – Male Twist to Connect | 439-1589 |
| Quick Disconnect Coupling – Female Twist to Connect | 439-1588 |

* Not applicable for serial number prefix SNZ, KW4, FRK, P3K, REP, W8K

BUILT FOR IT.™

