

# C7.2

Engine | 275-370 bhp (205-276 kW) | 860-934 lb-ft (1166-1267 Nm)

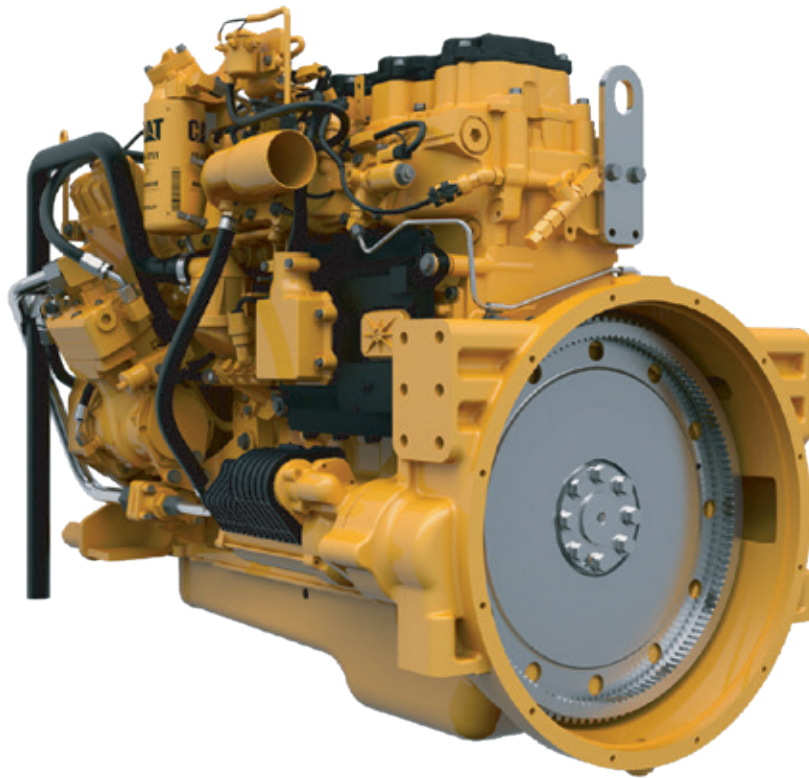

**Get legendary Cat reliability and durability with low operating costs using the Cat® C7.2 ACERT™ Diesel Engines.**

Based on decades of diesel engine innovation and expertise, these engines are designed for severe duty equipment and the most demanding environments and applications around the world.

More importantly, they are backed by the Cat® global dealer network ready to keep missions moving anywhere in the world.

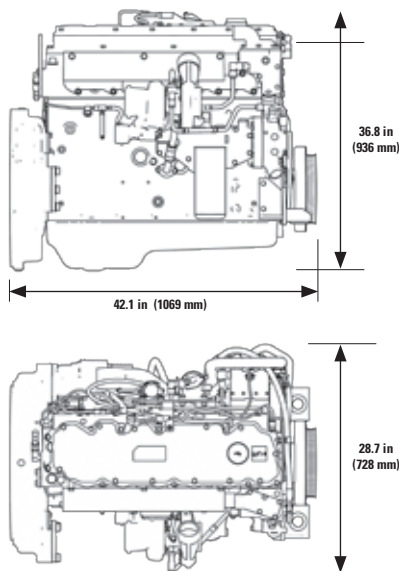

#### Built to Power:

Wheeled and Tracked APCs

Wheeled MRAPs

Medium Weight Utility Trucks

All Terrain Tracked Carriers

#### Specifications

Engine Configuration	In-line 6 Cylinder
Bore and Stroke (in/mm)	4.33 x 5.0 / 110 x 127
Displacement (in <sup>3</sup> /L)	442 / 7.2
Aspiration	Turbocharged and Aftercooled
Cycle	4 Stroke
Combustion System	Direct Injection
Compression Ratio	16.5:1
Rotation from Flywheel End	Counterclockwise
Oil Capacity (gal/L)	5.5 / 21
Cooling System	Liquid
Coolant Capacity (gal/L)	3.5 / 13.2
Dry Weight (lb/kg)	1,497 / 679

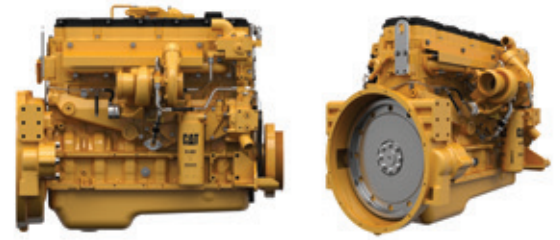

## Superior power at speed. (based on SAE J1995)

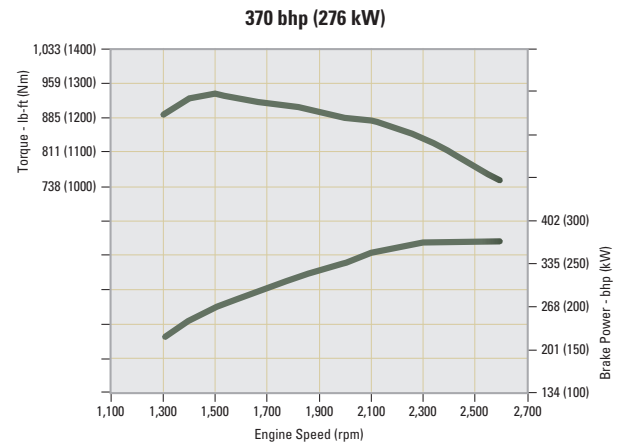
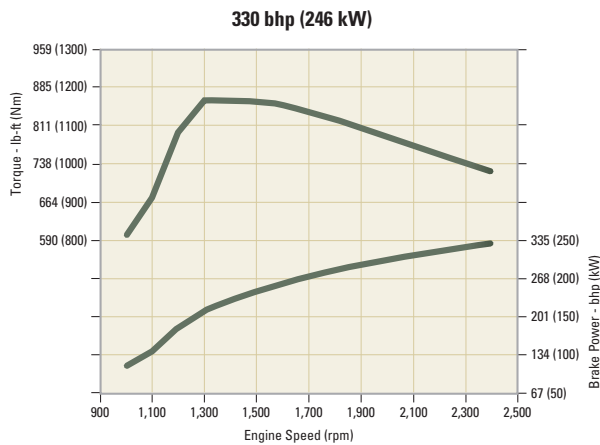

Brake Power (bhp/kW)	Speed (rpm)	Torque (lb-ft/Nm)	Speed (rpm)	Emission Level
300 / 224	2,200	860 / 1166	1,440	Euro III*
330 / 246	2,400	860 / 1166	1,440	Unregulated & Euro III*
350 / 261	2,600	854 / 1158	1,500	Unregulated
370 / 276	2,600	934 / 1267	1,500	Unregulated

## Standard Equipment

### Air Inlet and Exhaust System

- Turbocharger
- Inlet manifold heater
- Exhaust manifold, dry

### Control System

- Electronic governing, PTO speed control
- Automatic altitude compensation
- Power compensation for fuel temperature
- Programmable low and high idle and total engine limit
- Electronic diagnostics and fault logging
- SAE J1939 broadcast and control
- ADEM™ A4 Electronic Control Unit (ECU)

### Cooling System

- Thermostats and housing
- Jacket water pump, centrifugal
- Water pump, inlet

### Flywheels and Flywheel Housing

- SAE No. 1, No. 2 or No. 3 flywheel housing

### Fuel System

- HEUI™ injection
- Fuel filter, secondary (2 micron)
- ACERT™ Technology
- Fuel transfer pump

### Lube System

- Crankcase breather
- Oil cooler
- Oil filler
- Lube oil filter
- Oil pan
- Oil dipstick
- Gear driven oil pump

### General

- Vibration damper
- Lifting eyes

\* Emits equivalent to Euro III. Does not meet current EU emission standards.