



Document Number: JA-COR-0001			
Title: Production Part Approval Process (PPAP)			
Issue Date: 03/13/2016	Revision Date: 7/7/2020	Revision Level: 12	Page: 1 of 18

<u>Paragraph</u>	<u>Table of Contents</u>	<u>Page</u>
1.0	REASONS FOR PPAP SUBMISSION	3
2.0	SUBMISSION REQUIREMENTS	3
3.0	OTHER GENERAL PPAP REQUIREMENTS	5
4.0	THE ETQ PPAP APPROVAL PROCESS	5
5.0	PPAP SUBMISSION ELEMENTS	9
6.0	RECORDS RETENTION	17

	Document Number: JA-COR-0001		
	Title: Production Part Approval Process (PPAP)		
	Issue Date: 03/13/2016	Revision Date: 7/7/2020	Revision Level: 12
		Page: 2 of 18	

REVISION RECORD

Detailed Description of Change(s)	Rev	Date	Originator
Initial release after change to new document numbering system.	1	03/13/2016	Greg Prong
1. Added section 3, "Acknowledge" phase to reflect the update PPAP workflow / phases. 2. Modified to reflect the new use of the ETQ SPAP system for production tooling qualification for PR / Progress Rail manufacturing tooling, where such tooling is purchased from tooling sources outside of PR / Progress Rail. 3. Updated hyperlinks to reflect document locations on the revised Progress Rail website.	2	05/09/2016	Greg Prong
1. Edited the default submission requirements table in 2.0 to match the latest update done in ETQ's SPAP module. 2. Added 'Parts produced at additional location' as a reason in 1.0 3. Updated the introduction paragraph. 4. Added VOIDED section in 4.0 5. Revision changed to 5 to sync the revision in this document and in SharePoint metadata.	5	08/15/2016	Eddie Bheda
1. Removed redline from the last revision's approved edits. 2. Updated the voided condition 3. Added electronic SPAP approval process in section 4.0	6	1/17/2017	Eddie Bheda
Updated the company logo to Progress Rail.	7	1/20/2017	Eddie Bheda
Updated and added hyperlinks. Corrected document ID of the SPAP warrant form. Added minimum SPAP record retention period note to section 2.0. Updated phase tracker image to reflect latest version of workflow. Replaced section 3 "Acknowledgement" phase details (no longer a phase) with the "Hash Tag Voided" phase. Adjusted document formatting. Updated Table of contents page numbers.	8	7/31/2019	Greg Prong
Updated SPAP to PPAP. Added a note in 'At Supplier' section about supplier submission and responsibility. Deleted the PPAP Warrant references. The ETQ form already has questions which once filled out are considered as an Electronic PPAP Warrant.	9	10/23/2019	Aditya Bheda
Updated procedure to Production Part Approval Process	10	10/24/2019	Aditya Bheda
Corrected hyperlinks to the ETQ system's PPAP and Deviation modules. Reconfirmed all other hyperlinks were working.	11	1/17/2020	Greg Prong
Updated section 3.0 with software quality and English documents requirement. Updated section 5.0- K.	12	7/7/2020	Aditya Bheda

	Document Number: JA-COR-0001			
	Title: Production Part Approval Process (PPAP)			
	Issue Date: 03/13/2016	Revision Date: 7/7/2020	Revision Level: 12	Page: 3 of 18

Progress Rail (PR) uses the [Production Part Approval Process \(PPAP\)](#) software application to document a supplier’s compliance to PR design specifications and process capability to consistently meet those requirements. The PPAP requirement is applicable to production and service parts and raw material purchased by PR and is applied against the part number that appears on the associated PO. The Supplier is required to obtain PPAP Approval prior to delivery of the first shipment.

The process is also applicable to suppliers of PR purchased production tooling.

1.0 Reasons for PPAP Submission:

PPAP submission is required for any one or more of the following conditions.

- New production or service part.
- Any change in the production process, production equipment, process controls, or manufacturing location.
- Part design change initiated by either PR or supplier.
- Correction of a discrepancy on previously approved material.
- Use of material that is different from that used in a previously approved part.
- Tooling that is new, modified, refurbished or replaced, or, tooling that is transferred to other locations.
- Change in sub-supplier for parts or services.
- Parts that have not shipped to PR for more than 4 years.
- Parts produced at additional location

2.0 Submission Requirements

Refer to Table 1 below for default PPAP submission requirements for production or service parts based on PR PPAP risk categorization guidelines. The risk categories are determined by the SQE. (SQE, see [JA-COR-0004](#))

 Progress Rail <i>A Caterpillar Company</i>	Document Number: JA-COR-0001			
	Title: Production Part Approval Process (PPAP)			
	Issue Date: 03/13/2016	Revision Date: 7/7/2020	Revision Level: 12	Page: 4 of 18

Table 1: Default PPAP Submission Requirements:

PR Default PPAP Submission Requirements by PPAP Risk Category			
PPAP Element	High Risk	Medium Risk	Low Risk
A. Engineering change documents if applicable (MCR, DCR)	Yes	Yes	No
B. Full dimensional results with ballooned drawings	Yes	Yes	No
C. Process flow diagram	Yes	No	No
D. Control plan	Yes	No	No
E. Material test results	Yes	Yes	No
F. Performance test results	Yes	Yes	No
G. Measurement system studies (R & R studies)	For special characteristics only.	No	No
H. Process capability studies for KPCs (Cpk, Ppk)	For special characteristics only.	No.	No
I. Certificate of compliance to finish requirements (if applicable)	Yes	Yes	No
J. Sample product with PPAP labels applied	Yes	No	No
K. Description of packaging	Yes	No	No

The PR SQE or Tooling Engineer (TE) has the authority to revise the PPAP submission requirements based on the criticality / risk of the PPAP being submitted and, if applicable, the nature of the change(s) that trigger the need for PPAP approval. Such changes may be additions to the submission requirements or waivers to one or more of the default requirements.

The ETQ PPAP system includes a “Requirements” phase, which serves to document and communicate the specific PPAP submission requirements, including any additions or waivers for a particular PPAP event.

The supplier must maintain full records of the PPAP documentation, in the supplier’s internal files and shall furnish those records to PR upon request. See section 6 for minimum retention periods.

 Progress Rail <i>A Caterpillar Company</i>	Document Number: JA-COR-0001			
	Title: Production Part Approval Process (PPAP)			
	Issue Date: 03/13/2016	Revision Date: 7/7/2020	Revision Level: 12	Page: 5 of 18

3.0 Other General PPAP Requirements

The Supplier shall ensure that appropriate controls are applied to internal processes as well as to sub-suppliers to ensure the quality of their incoming and internal components and materials. Upon PR request, the Supplier shall provide copies of those qualification records as part of the PPAP process.

All PPAP documentation submitted must be submitted in English. Documents with dual languages are acceptable, but English needs to be included.

If the supplier’s product or component includes software then a statement of conformance to EN 50129, EN 50128, EN 50159, 49CFR229 subpart E is required within the PPAP submission.

PR reserves the right to conduct a PPAP review at the Supplier’s site. PR shall provide written notification of the intent for an on-site review.

Critical Fasteners listed in ETI 506 are never considered Commodity Parts. For more information, and to confirm if your fastener part number(s) are considered critical fasteners, please refer to [ETI 506, “Quality Control of Critical Fasteners”](#).

Contact your Buyer for a copy of the latest version of this document.

4.0 The ETQ PPAP Approval Process

PR uses the online ETQ PPAP module to manage the PPAP process. This system processes PPAP’s via the following PPAP workflow phases.



This workflow has the following phases:

1. “Initiate” (Owner: PR – ETQ Administrator)

This step is the initial trigger step. The PR ETQ administrator will review the initially triggered PPAP record and confirm that it is a valid PPAP event.

 Progress Rail <i>A Caterpillar Company</i>	Document Number: JA-COR-0001			
	Title: Production Part Approval Process (PPAP)			
	Issue Date: 03/13/2016	Revision Date: 7/7/2020	Revision Level: 12	Page: 6 of 18

- If a PPAP is required, then the PPAP record is assigned to the SQE and pushed to the “Requirements” phase.
- If a PPAP is not required, then the PPAP record is cancelled and will not progress any further.

 <p>Progress Rail A Caterpillar Company</p>	Document Number: JA-COR-0001			
	Title: Production Part Approval Process (PPAP)			
	Issue Date: 03/13/2016	Revision Date: 7/7/2020	Revision Level: 12	Page: 7 of 18

2. “Requirements” (Owner: PR – SQE)

At this phase, the assigned SQE or TE checks off submission checklist items to indicate which submission content / documentation will be required in order to obtain PPAP approval. Once defined, the PPAP is moved to the “At Supplier” phase.

3. “Hash Tag Voided” (Owner: PR – Administrator)

This is an Administration only phase used to Void PPAPs where it is administratively required to do so. Suppliers will not see PPAPs at this phase, as it is an internal PR administration phase only.

4. “At Supplier” (Owner: Assigned Supplier)

At this phase, the supplier uploads the necessary documentation per the submission checklist. When the supplier uploads all required documentation, the supplier pushes the PPAP into the “Disposition” phase.

The supplier is expected to obtain approval from PR for any deviation or permanent change to PR engineering specifications prior to submission. This approval can be requested by electronically initiating a Supplier Deviation request from the [ETQ Deviation system](#). From the “Help Documents” view within the Deviation system itself, you can access additional information on the system’s use.

It is expected that all non-conformances to PR specifications are approved through the DA process prior to submission of the PPAP and that copies of all approved DA’s are included in the submitted PPAP documentation.

The supplier is responsible to ensure that the evidence submitted meets all specified PPAP and part requirements. If it is found that the evidence is missing or does not conform to the requirements the supplier will be held responsible for non-conforming material.

5. “Disposition” (Owner: PR – SQE)

At this phase, the PR SQE / TE reviews the submitted information package and assigns a PPAP approval status as either:

Interim Approval:

The PPAP is approved and parts are approved for shipment, but some conditions apply (e.g. Quantity restriction, time restriction, fit / form / function trials required, etc.). The specific approval conditions are documented in the PPAP record.

The SQE pushes the PPAP record forward to the “Interim Approval At Supplier” phase where the conditions for PPAP approval are to be resolved and missing information re-submitted.

The Supplier and SQE jointly work to resolve outstanding issues.

 <p>Progress Rail A Caterpillar Company</p>	Document Number: JA-COR-0001			
	Title: Production Part Approval Process (PPAP)			
	Issue Date: 03/13/2016	Revision Date: 7/7/2020	Revision Level: 12	Page: 8 of 18

Full Approval

The PPAP is approved fully and parts are approved for shipment with no quality related restrictions. The supplier must still meet PO delivery requirements for both delivery date and quantity.

The SQE pushes the PPAP to the “Approved” phase, which completes the PPAP approval process.

Rejected:

The PPAP is rejected and the supplier is not authorized to ship parts until outstanding issues are resolved and a subsequent interim or full approval is granted.

The PR SQE pushes the ETQ PPAP record back to the “At Supplier” phase so that the PPAP issues can be resolved. The Supplier and the SQE work to resolve the issues.

Voided:

The PPAP can be # voided when all of the following conditions have been met:

- The part was shipped without a PPAP or the part wasn’t shipped at all
- There is no future demand or all the POs have been cancelled

If all the above conditions are met, VOID PPAP, note that the part was shipped without a PPAP and there is no future demand or the POs have been cancelled. Tag the PPAP with a #. This is the code to identify the PPAPs that are voided using the above conditions.

6. “Interim Approval at Supplier” (Owner: Assigned Supplier)

At this phase, the supplier is approved to ship parts provided they remain compliant with the established conditions that were documented for the interim approval. The supplier is expected to resolve any outstanding issues and upload the necessary documents to clear the outstanding conditions for full approval.

Once all outstanding documentation has been uploaded by the supplier, the supplier pushes the PPAP record to the “Resubmission” phase.

 <p>Progress Rail A Caterpillar Company</p>	Document Number: JA-COR-0001			
	Title: Production Part Approval Process (PPAP)			
	Issue Date: 03/13/2016	Revision Date: 7/7/2020	Revision Level: 12	Page: 9 of 18

7. “Resubmission” (Owner: PR SQE)

At this phase (similar to the “Disposition” phase), the PR SQE / TE reviews the submitted information package and determines PPAP approval status as either:

- Interim Approval:
- Full Approval
- Rejected:

See the “Disposition” phase for more details on the approval status codes and the resulting lifecycle phase to which the PPAP is moved.

8. “Approved” (Owner: PR – SQE):

This is the final phase which simply indicates that the PPAP is approved.

Electronic PPAP Approval for Certain Parts

The PPAP process is automated for low and medium risk parts, categorized as such by the SQE. Once such a PPAP is moved to the disposition phase, EtQ will look for two conditions to be met and if so, will approve the PPAP.

The two conditions are:

- If the supplier checked “YES” that the documentation/evidence has been submitted for all specified PPAP requirements, AND
- If the supplier checked “YES” for the supplier declaration of conformance question.

The automatic approval function runs in the evening daily and will generate an email back to the supplier. It also then moves the PPAP to approved phase.

	Document Number: JA-COR-0001			
	Title: Production Part Approval Process (PPAP)			
	Issue Date: 03/13/2016	Revision Date: 7/7/2020	Revision Level: 12	Page: 10 of 18

5.0 PPAP Submission Elements

The following section identifies the key requirements for individual PPAP submission elements. There may be additional elements beyond those described in this section. Consult your assigned SQE or TE for any clarification that you need.

NOTE: For tooling PPAPs, the following items are typically not required unless specifically requested by the assigned TE:

- Process flow diagram
- Process FMEA
- Process control plan
- Weld qualification records
- Process capability studies
- Measurement system studies
- Appearance approval
- Packaging instructions

The Supplier shall comply with these requirements when the individual PPAP element is included as part of the required overall PPAP submission content. Failure to comply with any of the requirements may result in rejection of the PPAP submission.

 Progress Rail <i>A Caterpillar Company</i>	Document Number: JA-COR-0001			
	Title: Production Part Approval Process (PPAP)			
	Issue Date: 03/13/2016	Revision Date: 7/7/2020	Revision Level: 12	Page: 11 of 18

A. Engineering Change Documents – It is the supplier’s responsibility to recognize when non-conformities exist as they work through the initial contract feasibility review, through planning and preparation of the PPAP and to take the appropriate corrective action to resolve any such non-conformities.

Temporary Change Requests:

If the supplier needs some short term relief for non-conformance to one or more of the requirements (dimension, material, performance specification, etc.) in order to meet PR production delivery dates and to buy some time for the Supplier to implement the necessary corrective actions, the Supplier may request temporary deviation through a Supplier deviation request.

In this case, the Supplier shall initiate the Deviation request using the [ETQ Deviation system](#). Once the Supplier has initiated the request and sent it to the “Assignment” phase, the system will route the request internally for PR review, approval and release. Once the Deviation is dispositioned, the system forwards a status email to the Supplier contact indicating if it is approved or not. If approved, the Supplier shall include a reference to the approved DA number within the PPAP. If not approved, the Supplier must correct the non-conformance prior to PPAP submission.

You can look at the approval routing and current status of the Deviation request at any time from within the ETQ Deviation system.

There is no guarantee that the Deviation request will be approved, and if not approved, there may be a significant disruption to PR’s production schedule. Therefore, it is important to work diligently to prevent non-conformances in the first place. Tools to aid in the prevention of con-conformance may include process feasibility assessments at the quote stage, product and process design reviews including resolution of any tolerance, processing or other issues as early as possible, well in advance of the PPAP date.

Permanent Change Requests:

If the Supplier deems that all reasonable efforts to correct the part / process have been exhausted, and the non-conformity still cannot be resolved, then the Supplier may apply for permanent change approval using either a Design Change Request (DCR) or Manufacturing Change Request (MCR). These change requests should be initiated early in the process through your PR Buyer, PR Engineering or the assigned PR SQE. PR will internally route the request for PR review, approval and release.

If the request is approved, then a copy of the approval (signed DCR or MCR) shall be provided to the Supplier who shall submit a copy of the approved document with the PPAP.

Document Number: JA-COR-0001			
Title: Production Part Approval Process (PPAP)			
Issue Date: 03/13/2016	Revision Date: 7/7/2020	Revision Level: 12	Page: 12 of 18

There is no guarantee that the change request will be approved, and if not approved, there may be a significant disruption to PR’s production schedule. Therefore, it is important to work diligently to prevent non-conformances in the first place. Tools to aid in the prevention of con-conformance may include process feasibility assessments at the quote stage, product and process design reviews including resolution of any tolerance, processing or other issues as early as possible, well in advance of the PPAP date.

B. Full Dimensional Results with Ballooned Drawings – For each part number for which dimensional results are provided in the PPAP, there must be an accompanying ballooned design record (typically a drawing) submitted.

The ballooned drawing indicates which dimensions, specifications, notes etc. have accompanying data submitted. The expectation is that all dimensions, specifications, notes, etc. are included in the submission unless waived as part of the PPAP requirements provided to the Supplier by PR.

Each measured or evaluated feature or specification shall have an associated identification balloon. The balloon is a circle with a unique id number inside.

See example illustration of a ballooned drawing section below:

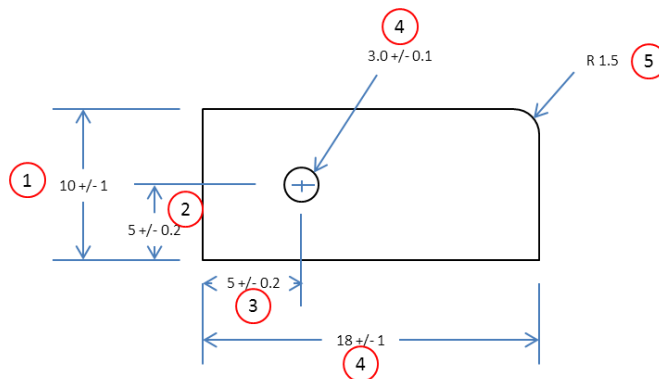

The supplier shall submit measurements for all dimensions, specifications, notes, etc., unless otherwise waived by the SQE / TE and inspection results shall be supplied for a minimum of 2 PPAP samples. For multiple process streams (e.g. multiple cavity tools, duplicate assembly lines, multiple cell manufacturing, etc.), two sample parts per process stream are required for inspection unless otherwise agreed.

	Document Number: JA-COR-0001			
	Title: Production Part Approval Process (PPAP)			
	Issue Date: 03/13/2016	Revision Date: 7/7/2020	Revision Level: 12	Page: 13 of 18

For example, a PPAP for parts on a 2-up die would have dimensional results for 2 parts from cavity 1 and 2 parts from cavity 2 for a total of 4 PPAP sample parts.

The dimensional report shall include at a minimum, the following information.

- Balloon ID number (from the associated ballooned drawing) for each measured feature
- Specification / Requirement for each measured or evaluated feature
- Measured results for each required measured PPAP sample with identification of which sample the measurement applies to.
- Pass / Fail status for each measured feature
- The date of inspection
- The name of the person who executed the inspection(s)
- A conformance statement indicating whether the inspection results passed or failed to meet the acceptance criteria.

The sample parts should be the same part(s) that were inspected.

C. Process Flow Diagram – Unless otherwise waived by the SQE, the supplier shall provide a process flow diagram indicating the sequence of steps used to manufacture the product. The format of the process flow diagram is not specified by PR; however, PR has provided a Microsoft Excel template that may be used by the Supplier at their discretion. This [template file](#), which includes templates for a process flow diagram, a process FMEA and a process control plan, can be found on the PR web site.

D. Control Plan - Unless otherwise waived by the SQE, the Supplier shall provide a Process Control Plan document. The file format of the Control Plan is not specified by PR; however, PR has provided a Microsoft Excel template that may be used by the Supplier at their discretion. This [template file](#), which includes templates for a process flow diagram, a process FMEA and a process control plan, can be found on the PR web site.

For more information on how to effectively develop a Control Plan, you can order an [AIAG Control Plan Manual](#) from the [AIAG](#) website.

E. Material Test Results –

The supplier must perform tests for all parts when chemical, physical, or metallurgical requirements are specified in the design specifications. This includes the requirements of the PR Material Specification, heat treating and all PR Engineering Test Instructions (ETIs) listed on the drawing or related specifications.

Unless waived by Progress Rail in the PPAP requirements, all castings and forgings must be tested in accordance with [ETI 827](#) or [ETI 930](#) respectively whether supplied to PR in the rough, semi-finished or

 Progress Rail <i>A Caterpillar Company</i>	Document Number: JA-COR-0001			
	Title: Production Part Approval Process (PPAP)			
	Issue Date: 03/13/2016	Revision Date: 7/7/2020	Revision Level: 12	Page: 14 of 18

finished conditions. The supplier must indicate the drawing revision level of the parts tested, revision level of the specifications to which the part was tested and date on which testing took place. Any authorized engineering change documents (CR) that have not been yet incorporated in the design specifications must be indicated. All tests required should be listed in an understandable format along with the quantity tested and the actual results of each test.

Consult your Buyer for the latest copies of ETI 827 and ETI 930.

To avoid delays in approval, test samples for fulfilling the requirements of this section should be pre-submitted to:

Manager – PR Materials Engineering Lab, Dept. 850,
 9301 W. 55th Street,
 McCook, IL 60525

The supplier shall copy the applicable SQE or TE and Buyer on test samples sent directly to PR Materials Engineering Lab.

The resulting PR Materials Lab Report must then be submitted with the final PPAP submission.

F. Performance Test Results –

Test results are required to be submitted when there are separate performance specifications other than material specifications. These could be VTS, ETI, leak test, pressure test, electrical test, mechanical tests etc. [Engineering Approval for Functional Performance](#) form can be requested by the SQE for this section in addition to the documents submitted by the supplier for this section.

G. Measurement System Studies – Measurement systems studies are to be provided when requested to indicate the ability of the measurement system to reliably measure the associated feature(s). PR requires these studies only for measurement systems that measure special characteristics identified on the drawing.

Measurement system studies should follow the requirements of the [AIAG Measurement Systems Analysis \(MSA\) Manual](#), which can be purchased from the [AIAG](#).

If the measurements are attribute in nature (i.e. they generate only a Pass / Fail result), then PR recommends the AIAG Attribute Gage Study method.

If the measurements are variable in nature (i.e. they result in a numerical value, such as 1.245 inches, rather than just a Pass / Fail result), then PR recommends the Supplier use the AIAG Average and Range method to assess the measurement system due to its more simplistic approach.

 Progress Rail <i>A Caterpillar Company</i>	Document Number: JA-COR-0001			
	Title: Production Part Approval Process (PPAP)			
	Issue Date: 03/13/2016	Revision Date: 7/7/2020	Revision Level: 12	Page: 15 of 18

There are other suitable methods for assessing measurement system effectiveness that can be used. If you will be using an alternate method, contact your SQE in advance to ensure acceptability.

- H. Process Capability Studies for KPCs** – PR requires process capability results for special characteristics only, unless otherwise requested by the PR SQE. Refer to form [FRM-SE-0015 “PR Process Capability Report”](#) for further information on sample sizes, acceptance criteria for the analysis, etc.

If the required targets for process capability cannot be met for special characteristics, then the Supplier must initiate a 100% inspection activity for those characteristics. This 100% inspection activity must be documented on the process control plan.

- I. Certificate of Compliance to Finish Requirements** – Evidence for compliance of the part appearance is required for parts that are painted or otherwise finished (e.g. zinc dichromate, phosphate and oil finishing, etc.).

The supplier must comply with the requirements of [AI 2719, “Surface Finish Requirement”](#) where required. Please refer to AI 2719 for specific requirements. Contact your Buyer for a copy of the latest version of this document.

For painted parts, typical evidence of conformance includes:

- Technical data sheets from the manufacturer of the primers and top coat paints used. The sheets must indicate the use of the correct PR approved primers / paints (reference AI 2719).
- Evaluation of color match and gloss as compared to master color and gloss chip. Master chips can be purchased from the paint manufacturer. PR suggests reporting the results of this evaluation on the Inspection report.
- Film thickness measurement
- Adhesion and other specified test results in accordance with testing and methods referenced in AI 2719.
- Visual inspection for the presence of visual paint discontinuities and defects such as dings, weld spatter, drips, orange peel, etc. as referenced in the “Appearance” section of AI 2719. PR suggests reporting the results of this evaluation on the Inspection report.
- Visual assessment for conformance to any paint masking diagrams that are applicable to the part. PR suggests the reporting of this evaluation on the Inspection report.

For other finish surfaces, certificates of conformance from the organization providing the finishing service may be provided.

If you are unclear on the specific requirements for appearance approval, consult you PR SQE for clarification.

 Progress Rail <i>A Caterpillar Company</i>	Document Number: JA-COR-0001			
	Title: Production Part Approval Process (PPAP)			
	Issue Date: 03/13/2016	Revision Date: 7/7/2020	Revision Level: 12	Page: 16 of 18

J. Sample Product with PPAP Labels Applied – PPAP samples shall be identified as such using tags, or where tags are not practical, through labeling of the container or packaging. The identification shall include at a minimum:

- The PPAP ID number (obtained from the ETQ system)
- PR Part number and PR engineering revision
- Part description
- Supplier name, facility that is providing the PPAP and the city in which that facility is located
- PO number against which the first delivery of parts will be shipped
- The name of the PR point of contact that is to receive the PPAP samples

PR has provided a PPAP Parts template label that can be attached to the part or part packaging that contains the above information fields.

Reference the PPAP Parts label form '[FRM-COR-6306 - PPAP Samples Label](#)' on the PR website.

K. Description of Packaging –The Supplier must submit a completed [FRM-COR-6439](#). The Supplier is responsible to package the part in a manner that adequately protects the parts from damage or other negative effects due to the environment through which the part is transported and in which the part is stored. The packaging must also meet all other Progress Rail packaging criteria (i.e. no supplier logo on parts or packaging). This requirement exists regardless of the final destination of the shipped part and Supplier should consider the packaging needs for parts that are shipped via ground transportation in the USA versus, for example, the same part that may be shipped via ship overseas. A packaging instruction that indicates the planned method(s) for packaging must be submitted In addition to the packaging instruction, image(s) of the packaged parts that illustrate the packaging shall also be submitted as part of the PPAP unless otherwise waived by PR. Please refer to the [Progress Rail Shipping and Packaging Manual](#) on the Progress Rail website(<https://www.progressrail.com>) for shipping and packaging requirements.

L. Design Validation Test Results – Where identified as part of the PPAP submission requirements, and where functional, performance, durability or reliability requirements are specified in the PR specification (VTS, ETI, AI, EDPS, etc.), design validation test results shall be provided by the Supplier as evidence to indicate that the product design is capable of meeting such design requirements.

This element is 2-stage requirement.

First, the Supplier must provide both an initial completed copy of the [“Engineering Approval for Functional Performance”](#) form, as well as a full copy of the test results to PR Engineering for review and approval.

The test results, at a minimum, shall include the following:

	Document Number: JA-COR-0001			
	Title: Production Part Approval Process (PPAP)			
	Issue Date: 03/13/2016	Revision Date: 7/7/2020	Revision Level: 12	Page: 17 of 18

- List of planned validation tests including acceptance criteria
- The PR part number and PR Engineering revision levels for the tested parts
- Any deviation to the engineering specification that existed on the tested parts. These should be PR Engineering approved in writing prior to conducting the testing to avoid any disqualified test results
- Quantity of parts tested
- The date of test completion
- Test results for each of the planned tests
- A conformance status statement indicating whether the test results passed or failed to meet the acceptance criteria
- A signature from an authorized supplier representative and date of signature

PR Engineering shall review the submitted test information and resolve any discrepancies with the Supplier. Once the PR Engineer is satisfied with the test results, they shall sign the “Engineering Approval for Functional Performance” form and return it to the supplier.

In stage 2, the Supplier shall submit a copy of the PR approved “Engineering Approval of Functional Performance” form as well as the test results as part of the PPAP.

M. Weld Qualification Records – Where weld qualification is required, the supplier must submit with the PPAP evidence of compliance to PR specifications. For specific details, please refer to [AI 1651, “PR Welding, Brazing and Soldering Specification”](#).

For welding, this document defines the various requirements for weld procedure qualification, Weld Coordinator, Welder and Inspector qualifications, etc.

Contact your Buyer for a copy of the latest version of this document.

N. Process FMEA – Unless otherwise waived by the SQE, the Supplier shall provide a Process Failure Mode and Effects Analysis (PFMEA) document. The file format of the PFMEA is not specified by PR, however, PR has provided a Microsoft Excel template that may be used by the Supplier at their discretion. This [template file](#), which includes templates for a process flow diagram, a process FMEA and a process control plan, can be found on the PR web site.

For more information on how to effectively develop an FMEA, you can order an [AIAG FMEA Manual](#) from the [AIAG](#) website.

	Document Number: JA-COR-0001			
	Title: Production Part Approval Process (PPAP)			
	Issue Date: 03/13/2016	Revision Date: 7/7/2020	Revision Level: 12	Page: 18 of 18

6.0 Records Retention

The Supplier shall maintain a copy of the approved PPAP with all supporting documentation for as long as the part is active plus a minimum of seven years. The Supplier shall provide copies of the approved PPAP and supporting documents at any time within that retention period upon PR request.