



Progress Rail's Maintenance-of-Way (MOW) division was born out of the movement toward mechanization in the railroad industry and introduced the first Kershaw® Ballast Regulator in 1945.

Today, Progress Rail supplies Kershaw® MOW equipment, providing machines to all Class I railroads, transit and short lines and contractors around the world.

Our Kershaw® Model 12-12 Bridge Crane is designed to perform bridge and open deck trestle work, the Model 12-12 Bridge Crane has maximum lifting capacity of 1200 lbs. (544 kg) at 25 ft. from center of track. Upper deck and tie grapple are capable of 360° continuous rotation. The Bridge Crane is capable of handling bridge ties, caps, stringers and other bridge components.

Progress Rail
A Caterpillar Company

800-633-5766

progressrail.com

🐦 @Progress_Rail

KERSHAW® 12-12 BRIDGE CRANE

Frame: Welded construction, lower frame is structural steel and 1" (25.4 mm) thick steel plate for the slewing ring support. Upper deck is structural steel and formed deck plates. Frame covered by Five (5) Year Warranty. Oversize 46 7/8 inch diameter slewing ring rated for 80,000 ft-lb. Remote grease fittings for slewing ring and axle bearings. 8-channel 6,000 psi hydraulic swivel is accessible from upper deck.

Engine: Caterpillar C4.4, 131 HP @ 2200 rpm Tier IV Final

Transmission and Axles: 3" (76 mm) diameter solid axles with chain drive from separate hydraulic motors driving both axles. Travel speed: 20 mph (32 km/hr). Two (2) propel drive motors for quicker response in work mode. #100 drive chain with hardened tooth sprockets.

Hydraulic System: Hydrostatic propel system pressure compensated piston type pump direct coupled to engine. Deck rotation by hydraulic motor through gearbox. Hydraulic oil is filtered through a 100 mesh (145 micron) suction screen and 10 micron return line filter. Manifold-type stack valves for improved serviceability. Remote oil cooler accessible from ground level with dual electric cooling fans. Electric emergency pump.

Electrical System: 24VDC negative ground, 100 amp alternator, color coded and numbered wiring.

Air System: A 12 cfm (.34 m³/min) @1,250 rpm air compressor, engine oil lubricated, air-cooled; pressure - 100-120 psi (689-927 kPa), 15-gallon air tank.

Cab: Large enclosed cab with 99.5 cubic foot capacity. Ergonomically designed seat. Large front windshield with unobstructed view of boom operation through full range of motion. Hydraulic pilot-pressure bottom-ported joystick controls on operator seat with heat shields. Self-contained hydraulically driven air conditioner/heater/pressurizer unit mounted on rear wall of cab (roof mount optional). Remote controlled boom travel lock. Rubber suspension ladder steps. No service items located on cab roof on standard machine.

Wheels and Brakes: 16" (406 mm) cast steel wheels. External, individual composite brake shoes applied directly on the vertical centerline of wheel tread. Service brakes are air applied, spring released. Emergency/parking brakes are spring applied, air released. Optional hydraulic brakes available.

Capacities: Fuel: 75 gal. (284 liters), Hydraulic: 70 gal. (265 liters).

Weight: 23,000 lbs

Boom: Ultra-wide 32 inch (813 mm) spread base root boom mount. GV-12 grapple rotator. Equipped with 4,000 lb. capacity winch.

Optional Equipment: Basket grapple; single tie grapple; two tie grapple; timber grapple; concrete tie grapple; timber crane package; boom-mounted flail mower.

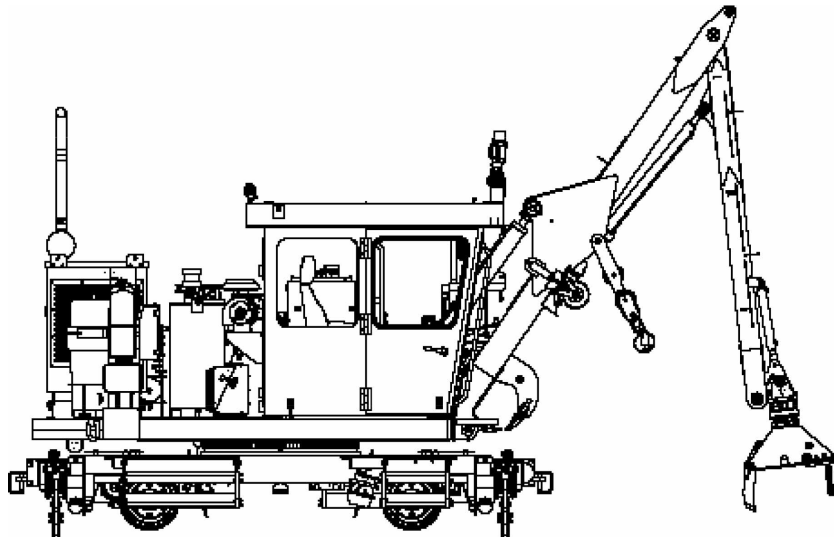

Progress Rail
A Caterpillar Company

800-633-5766

progressrail.com

🐦 @Progress_Rail