



Progress Rail's Maintenance-of-Way (MOW) division was born out of the movement toward mechanization in the railroad industry and introduced the first Kershaw® Ballast Regulator in 1945.

As a global supplier of Kershaw® MOW, utility and vegetation management equipment, we provide a comprehensive line of machines to help maintain rail infrastructure and right-of-ways around the world.

The Kershaw® Model 32-10 Brushcutter clears brush and overhanging branches from railroad right-of-way. It is capable of cutting up to 30 ft. (9144 mm) from the track center, and leaves behind a biodegradable mulch.

Progress Rail
A Caterpillar Company

800-633-5766

progressrail.com

▼ @Progress_Rail

KERSHAW® 32-10 BRUSHCUTTER

Frame: Welded construction of side frame member and formed plate cross-members.

Weight: 62,000 lb. (28123.2 kg)

Engine: Caterpillar C9.3B 335 hp @ 2200 rpm Tier IV Final

Propel System: Closed-loop variable displacement axial piston pump driving a fixed displacement axial piston motor. Maximum travel speed is 35 mph with full-time four-wheel drive.

Transmission and Axle: Hydrostatic transmission drives a 4-speed shift on the go gearbox. Front and rear automotive type axles with automatic positive locking differentials are driven through cardan shafts with slip joints.

Wheel and Brakes: 28 inch cast steel wheels are bolted to axle hubs. 4-wheel clasp brakes are axle mounted. Service brakes are air applied and spring released. Parking brakes are spring applied and air released. Suspension system utilizes coil springs.

Air System: Air compressor, engine oil lubricated, air cooled; 13 cu. ft free air volume @ 2200 rpm; system pressure 100 psi; 613 cu. in. air tank. Air is supplied to service brakes through a pressure reducing valve with pressure gauge. Parking brake is set by means of a electrically activated air dump valve. System is also equipped with dual tone air horns and a safety relief valve.

Hydraulic System: The engine drives a triple pump drive through a clutch. Two triple pumps power the cutter motors and the cutter head control circuits.

Electrical System: 24 volts dc negative ground; 150 amp alternator; color coded and numbered wiring.

Cab: The cab accommodates two operators (one for each cutterhead). Adequate height is provided for standing at entry door and rear section. Each operator has a set of foot pedals for controlling direction. The cab is equipped with heater, air conditioner, and a pressurization unit. Cab side walls are double wall construction (1/4" A514 over 11 ga.) with Lexan® marguard windows.

Capacities: **Fuel tank:** 110 gallons. **Hydraulic tank:** 100 gallons.

Cutterhead: Booms can rotate a 10 ft. wide double disk cutterhead outboard up to 30 ft. from rail centerline and 45° up/40° down from horizontal. Single boom operation is made possible by shifting a counterweight hydraulically to opposite side of the live cutterhead.

Turntable System: The Brushcutter has a turntable and can be turned manually.

Controls: Two 5-section valves (one for each operator) control the functions of the respective cutterheads. Boom in/out, up/down, and cutterhead pitch, tilt, and rotate are controlled by these valves. Travel direction is controlled by hydraulic foot pedals at each operator position.

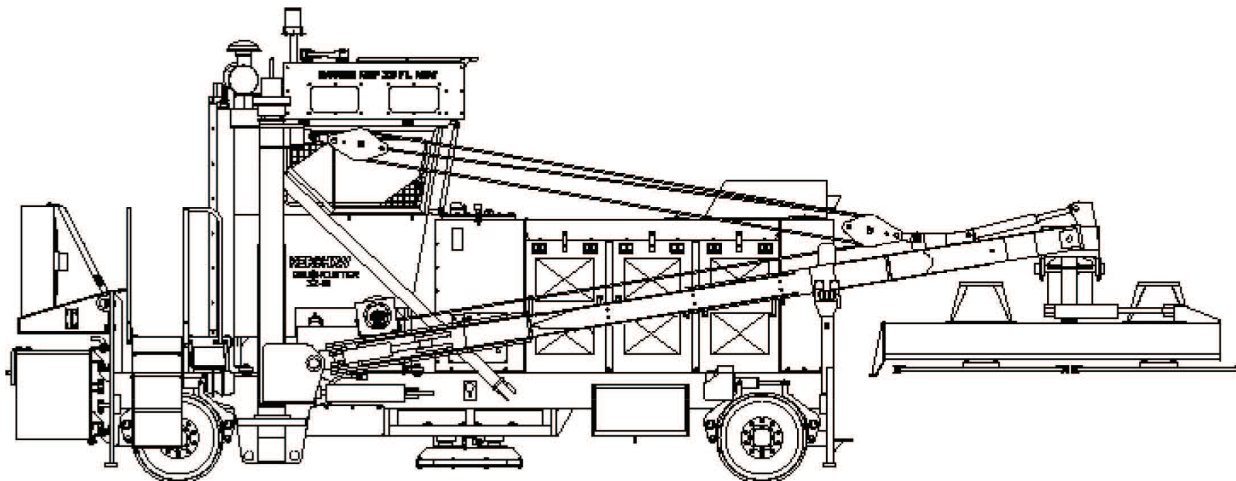

Progress Rail
A Caterpillar Company

800-633-5766

progressrail.com

▼ @Progress_Rail