

Model 60 Sand Remover

Progress Rail
A Caterpillar Company

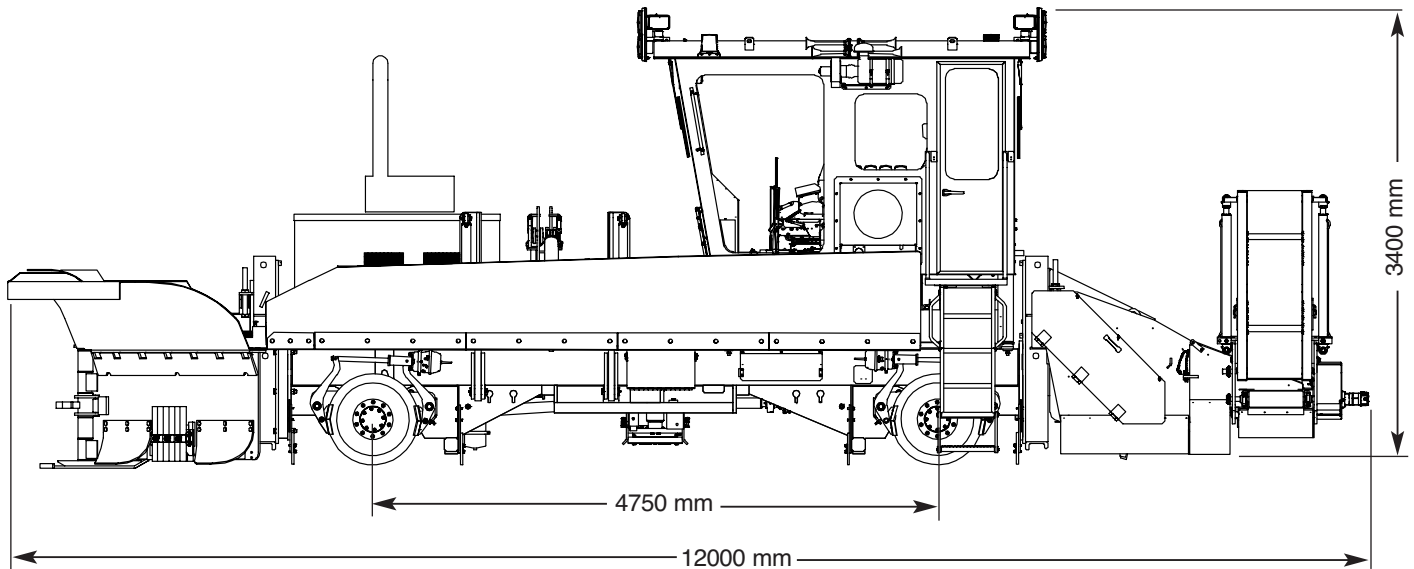

Description: The Model 60 Sand Remover is equipped with an articulating sand transfer plow, benching-type sand wings and a broom/conveyor attachment for sand removal from the track area. Articulating sand transfer plow removes sand up to 1.5 meters either side of track centerline. Sand wings remove sand up to 4 meters either side of track centerline. Conveyor attachment discharges sand from broom at 6 meters from track centerline. Multistage conveyor allows width to be minimized to less than 3 meters from the track centerline to clear obstructions.

Frame: Welded construction using 4 (101.6 mm) x 12 (304.8 mm) solid steel side members and structural steel cross members.

Weight: 50,020 lbs. (22689 kg)

Engine: Caterpillar C9, 300 (223.7 kw) hp @ 2200 rpm.

Propel System: Hydrostatic drive, variable displacement piston pump, variable displacement piston propel motor. Travel speed: 50 mph (80 km/hr); Work speed: 12.4 mph (20 km/hr).

Transmission and Axles: Hydraulic propel motor powers a 4-speed "shift on the go" transmission. Dual propeller shafts, two (2) spring-mounted 30,000 lb. (13608 kg) industrial type axles equipped with no spin differential. Equipped with 9 leaf spring suspension. Single control handle controls speed and direction in each range.

Wheels and Brakes: 28" (711 mm) cast steel wheels bolted to each axle, external clasp brakes (two shoes per wheel). Service brakes; air applied/spring released. Parking brakes; spring applied/air released.

Electrical System: 24 volt dc negative ground, 95 amp alternator, two 205 amp/hour batteries, color coded and numbered wiring.

Air System: Air compressor, engine oil lubricated, cam shaft driven, water-cooled, 13.2 ft³ (.37 m³/min) free air volume @ 1250 rpm. System pressure is 100-120 psi (758-927 kPa), 613 in.³ (10 liter) air tank. Service brakes are controlled by a pressure reducing valve and the parking brakes by a manually-operated dump valve. System is also equipped with a dual tone air horn, safety relief valve.

Hydraulic System: Engine-powered pump drive with clutch drives hydrostatic propel pump and pumps for controls and broom. Control circuit includes two pilot-pressure joysticks with electronic key pads, electrically actuated control valves and remote-mounted oil cooler. 100 mesh (145 micron) suction screens and 10 micron return filters. Electric emergency pump to operate selected circuits.

Cab: Extremely roomy cab. Fully enclosed and insulated with safety glass, dome light, dual front windshield wipers, and ergonomic seats. Cab access from either side of the machine. Equipped with self-contained vertical mount side wall heater/air conditioner. Cab is 75 inches (1905 mm) wide and 88 inches high (2235 mm).

Capacities: Fuel: 122.5 gal (464 liters), hydraulic: 98 gal (371 liters).

Options: V-Type Sand Plow

Illustrations and photographs may include optional equipment and may not include standard equipment.

October 6, 2016
Rev 0, ECO 31289

668467

ISO 9001
REGISTERED

www.ProgressRail.com
+1 (334) 387-9100