



Cat[®] 232D3

SKID STEER LOADER

FEATURES:

The Cat[®] 232D3 Skid Steer Loader, with its vertical lift design, delivers extended reach and lift height for quick and easy truck loading. Its stability and lifting performance provides excellent material handling. The 232D3 features the following:

- **Industry leading sealed and pressurized cab option** provides a cleaner and quieter operating environment with excellent work tool visibility.
- **Available high-back, heated, air ride seat with seat mounted adjustable joystick controls** makes the D3 Series the industry leader in operator comfort.
- **High performance power train** provides maximum performance and production capability through the Electronic Torque Management system and optional two speed travel.
- **High Flow hydraulic system** is available for applications that demand maximum hydraulic work tool performance.
- **Mechanically controlled Cat C2.2 engine** provides high horsepower and torque, allowing partial-throttle operation for lower sound levels and fuel consumption.
- **Cat "Intelligent Leveling" system** provides industry leading technology, integration, and available features such as dual direction self level, work tool return to dig, and work tool positioner.
- **Maximize machine capability and control** with optional Advanced Display providing on-screen adjustments for implement response, hystat response and creep control. Also features multi-language functionality with customizable layouts, security system and rearview camera.
- **Ground level access** to all daily service and routine maintenance points helps reduce machine downtime for greater productivity.
- **Broad range of performance matched Cat Work Tools** make the Cat Skid Steer Loader the most versatile machine on the job site.
- **Available Long Lasting LED Work Lights** (front and rear) provide superior job site illumination.

Specifications

Engine

Engine Model	Cat C2.2†	
Gross Power SAE J1995	44.9 kW	60.2 hp
Net Power SAE 1349	44.0 kW	58.9 hp
Net Power ISO 9249	44.4 kW	59.6 hp
Peak Torque at 1,500 rpm SAE J1995	183 N-m	135 lb-ft
Displacement	2.2 L	134.3 in ³
Stroke	100 mm	3.9 in
Bore	84 mm	3.3 in

†Engine meeting Brazil Mar-1 emission standards emits equivalent to U.S. EPA Tier 4 Interim.

Weights*

Operating Weight	2955 kg	6,514 lb
------------------	---------	----------

Power Train

Travel Speed (Forward or Reverse):

One Speed	12.3 km/h	7.6 mph
Two Speed Option	17.8 km/h	11.1 mph

Operating Specifications*

Rated Operating Capacity	865 kg	1,900 lb
Rated Operating Capacity with Optional Counterweight	910 kg	2,000 lb
Tipping Load	1725 kg	3,800 lb
Breakout Force, Tilt Cylinder	1782 kg	3,928 lb

Hydraulic System

Hydraulic Flow – Standard:

Loader Hydraulic Pressure	23 000 kPa	3,336 psi
Loader Hydraulic Flow	69 L/min	18 gal/min
Hydraulic Power (calculated)	26.5 kW	35.5 hp

Hydraulic Flow – High Flow:

Maximum Loader Hydraulic Pressure	23 000 kPa	3,336 psi
Maximum Loader Hydraulic Flow	99 L/min	26 gal/min
Hydraulic Power (calculated)	38.0 kW	50.9 hp



232D3 Skid Steer Loader

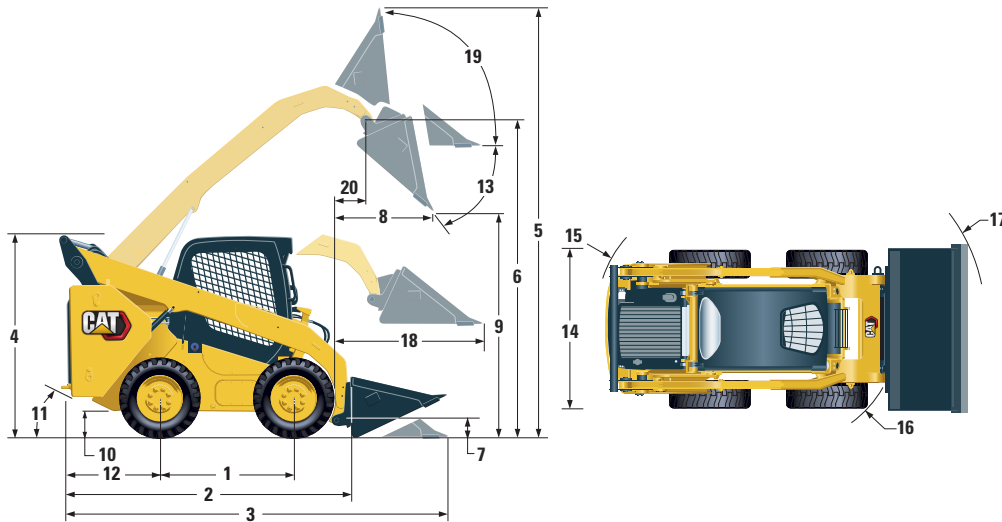

Dimensions*

1 Wheelbase	1054 mm	41.5 in	11 Departure Angle	27.9°
2 Length without Bucket	2523 mm	99.3 in	12 Bumper Overhang behind Rear Axle	894 mm 35.2 in
3 Length with Bucket on Ground	3233 mm	127.3 in	13 Maximum Dump Angle	47.4°
4 Height to Top of Cab	2029 mm	79.9 in	14 Vehicle Width over Tires	1497 mm 58.9 in
5 Maximum Overall Height	3832 mm	150.9 in	15 Turning Radius from Center – Machine Rear	1513 mm 59.6 in
6 Bucket Pin Height at Maximum Lift	3001 mm	118.1 in	16 Turning Radius from Center – Coupler	1102 mm 43.4 in
7 Bucket Pin Height at Carry Position	214 mm	8.4 in	17 Turning Radius from Center – Bucket	1976 mm 77.8 in
8 Reach at Maximum Lift and Dump	653 mm	25.7 in	18 Maximum Reach with Arms Parallel to Ground	1249 mm 49.2 in
9 Clearance at Maximum Lift and Dump	2254 mm	88.7 in	19 Rack Back Angle at Maximum Height	88.2°
10 Ground Clearance	170 mm	6.7 in	20 Bucket Pin Reach at Maximum Lift	224 mm 8.8 in

*Operating Weight, Operating Specifications and Dimensions all based on 75 kg (165 lb) operator, all fluids, single speed, 1576 mm (62 in) low profile bucket, **Cat 10 x 16.5 tires**, standard flow hydraulics, C1 cab (ROPS, mechanical seat), 850 CCA battery, manual quick coupler, no self level and no optional counterweights (unless otherwise noted).

Cab

ROPS	ISO 3471:2008
FOPS	ISO 3449:2005 Level I

Service Refill Capacities

Chain Box, each side	7 L	1.8 gal
Cooling System	12 L	3.2 gal
Engine Crankcase	10 L	2.6 gal
Fuel Tank	57 L	15.1 gal
Hydraulic System	45 L	11.9 gal
Hydraulic Tank	34 L	9.0 gal

Noise Level

Inside Cab**	83 dB(A)
Outside Cab***	101 dB(A)

**The declared dynamic operator sound pressure levels per ISO 6396:2008. The measurements were conducted with the cab doors and windows closed and at 70% of the maximum engine cooling fan speed. The sound level may vary at different engine cooling fan speeds.

***The labeled sound power level for the CE marked configurations when measured according to the test procedure and conditions specified in 2000/14/EC.

Air Conditioning System (if equipped)

The air conditioning system on this machine contains the fluorinated greenhouse gas refrigerant R134a (Global Warming Potential = 1430). The system contains 0.81 kg of refrigerant which has a CO₂ equivalent of 1.158 metric tonnes.

MANDATORY EQUIPMENT

- Hydraulics, Standard or High Flow
- Quick Coupler, Mechanical or Powered
- Highly Visible Seat Belt, 50 mm (2 in) or 75 mm (3 in)
- EU Preparation Package (Europe only)
- Power Train: One Speed, One Speed with Ride Control, Two Speed or Two Speed
- Tires, 10 × 16.5

PERFORMANCE PACKAGES

- Performance Package H1: *Standard Flow Hydraulics (No Self Level)*
- Performance Package H2: *Standard Flow Hydraulics, Dual Direction Electronic Self Level (Raise and Lower), Work Tool Return to Dig, Work Tool Positioner, and Electronic Snubbing (Raise and Lower)*
- Performance Package H3: *High Flow Hydraulics, Dual Direction Electronic Self Level (Raise and Lower), Work Tool Return to Dig, Work Tool Positioner, and Electronic Snubbing (Raise and Lower)*

STANDARD EQUIPMENT

ELECTRICAL

- 12 volt Electrical System
- 80 ampere Alternator
- Ignition Key Start/Stop Switch
- Lights: *Gauge Backlighting, Two Rear Tail Lights, Two Adjustable Front and Rear Halogen Lights, Dome Light*
- Backup Alarm
- Heavy Duty Battery, 850 CCA

OPERATOR ENVIRONMENT

- Gauges: *Fuel Level, Hour Meter*
- Operator Warning System Indicators: *Air Filter Restriction, Alternator Output, Armrest Raised/Operator Out of Seat, Engine Coolant Temperature, Engine Oil Pressure, Glow Plug Activation, Hydraulic Filter Restriction, Hydraulic Oil Temperature, Parking Brake Engaged*
- Fold In Ergonomic Contoured Armrest
- Control Interlock System, when operator leaves seat or armrest raised: *Hydraulic System Disables, Hydrostatic Transmission Disables, Parking Brake Engages*
- ROPS Cab, Open, Tilt Up
- FOPS, Level I
- Top and Rear Windows
- Floor Mat
- Interior Rearview Mirror
- 12 volt Electric Socket
- Horn
- Hand (Dial) Throttle, Electronic
- Adjustable Joystick Controls
- Anti-theft Security System with 6-button Keypad
- Storage Compartment with Netting

COMFORT PACKAGES

- Open ROPS (C1): *Foot Throttle, Headliner, Cup Holder, and choice of Seat (High Back, Heated, Air Ride Seat) (No Heater or Door)*
- Enclosed ROPS with A/C (C3): *Foot Throttle, Headliner, Heater and Defroster, Air Conditioner, Side Windows, Cup Holder, Radio Ready, choice of Seat (Mechanical Suspension or High Back, Heated, Air Ride Seat) and Door (Glass or Polycarbonate)*

POWER TRAIN

- Cat C2.2, Turbo Diesel Engine
- Air Cleaner, Dual Element, Radial Seal
- S-O-SSM Sampling Valve, Hydraulic Oil
- Filters, Cartridge-type, Hydraulic
- Filters, Canister-type, Fuel and Water Separator
- ATAAC/Radiator/Hydraulic Oil Cooler (side-by-side)
- Spring Applied, Hydraulically Released Parking Brakes
- Hydrostatic Transmission
- Four Wheel Chain Drive

OTHER

- Engine Enclosure, Lockable
- Extended Life Antifreeze, -36° C (-33° F)
- Machine Tie Down Points (6)
- Support, Lift Arm
- Hydraulic Oil Level Sight Gauge
- Radiator Coolant Level Sight Gauge
- Radiator, Expansion Bottle
- Cat ToughGuardTM Hose
- Auxiliary, Hydraulics, Continuous Flow
- Heavy Duty, Flat Faced Quick Disconnects with Integrated Pressure Release
- Split D-Ring to Route Work Tool Hoses Along Side of Left Lift Arm
- Electrical Outlet, Beacon
- Belly Pan Cleanout
- Variable Speed Demand Fan
- Product LinkTM PL240, Cellular

232D3 Skid Steer Loader

OPTIONAL EQUIPMENT

- External Counterweights
- Beacon, Rotating
- Engine Block Heater – 120V
- Oil, Hydraulic, Cold Operation
- Product Link PL641, Cellular
- Advanced Display with Rearview Camera: *Full Color, 127 mm (5 in) LCD screen, Advanced Multi-operator Security System, On-screen Adjustments for Implement Response, Hystat Response, and Creep Control; Standard equipment in Europe only*
- Bluetooth® Radio with Microphone (AM/FM/Weather Band Receiver with USB and Auxiliary Input Jack)



For more complete information on Cat products, dealer services, and industry solutions, visit us on the web at www.cat.com

© 2019 Caterpillar
All rights reserved

Materials and specifications are subject to change without notice. Featured machines in photos may include additional equipment. See your Cat dealer for available options.

CAT, CATERPILLAR, LET'S DO THE WORK, their respective logos, "Caterpillar Yellow," the "Power Edge" and Cat "Modern Hex" trade dress as well as corporate and product identity used herein, are trademarks of Caterpillar and may not be used without permission.

AEHQ8216 (08-2019)
(S Am, AME, CIS,
APD-LRC Regions)

