

Powering the Future Through Sustainable, Innovative Energy Solutions

The SMT60 is the answer for short-term generating capacity which is both economical and environmentally friendly. The SMT60 is designed for projects where fast setup and reliable operation are critical. This solution is based on the 5.7 MWe Taurus™ 60 gas turbine generator set – a proven industry standard.



COMPLETE SOLUTION

- Fully-Integrated Mobile Power Plant
- 13.8KV/12.47KV (60 Hz) Generator
- Dual Fuel System (Natural Gas and Diesel #2)
- Low Emissions SoLoNOx™ Combustion System
- Lightweight, Single Frame Design
- Compact Footprint for High Power Density
- Low-Profile Modular Design to Minimize Installed Height
- Easily Relocatable via Highway or Rugged Terrain
- Transcontinental Transportability by Ocean Freight
- World-Class Global Customer Support Network

PARK, PLUG AND POWER

- Quick and Innovative Setup – Less Than Four Hours
- No Concrete Foundation Required
- No Crane Lifts Required at Site
- Hydraulic Leveling System
- Lockable Low-Speed Coupling Minimizing Alignment

STANDARD FEATURES

- Wide Fuel Flexibility (Field Gas, CNG, LPG, etc.)
- Temperature Range from -18°C to 49°C (0°F to 120°F)
- Complete Electrical Equipment Compartment with Motor Control Center and HVAC
- Utility Grade Switchgear and Protective Relay Module
- Compact Medium Voltage Compartment
- Internal 120V Outlet; Optional External 120V Outlet
- Optional Sound Attenuation
- Add-On Option for Multi-Unit Power Management and Microgrid Control with Solar® StationEdge
- InSight™ Platform Compatible
- Digital Load Sharing Capability Across Solar Fleet
- Standard Offering at 25 PPM NOx with Optional Configurations Down to 15 and 9 PPM NOx

SMT 60

PERFORMANCE*

Output Power	5670 kWe
Heat Rate	11 430 kJ/kWe-hr (10,830 Btu/kWe-hr)

*ISO: 15°C (59°F), sea level

AVAILABLE POWER*

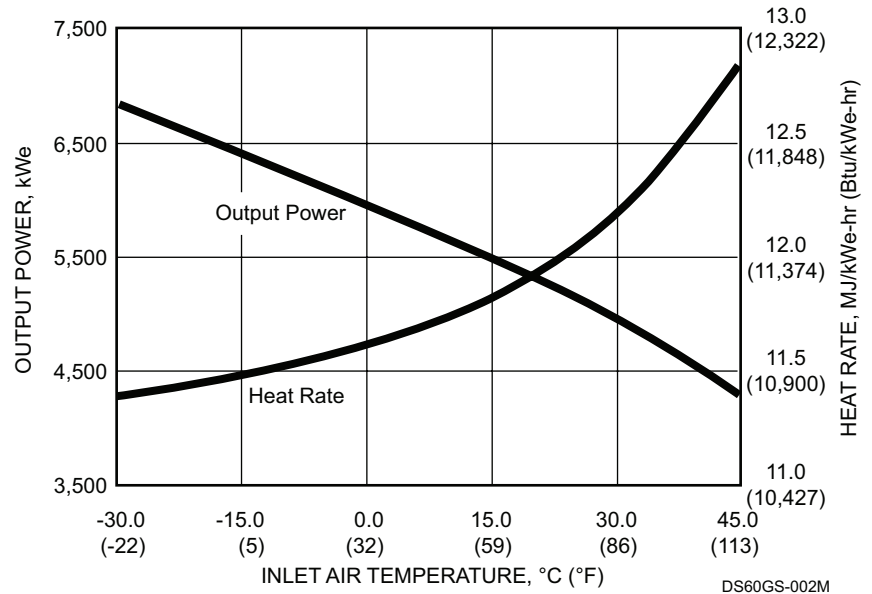

PACKAGE LAYOUT AND DIMENSIONS

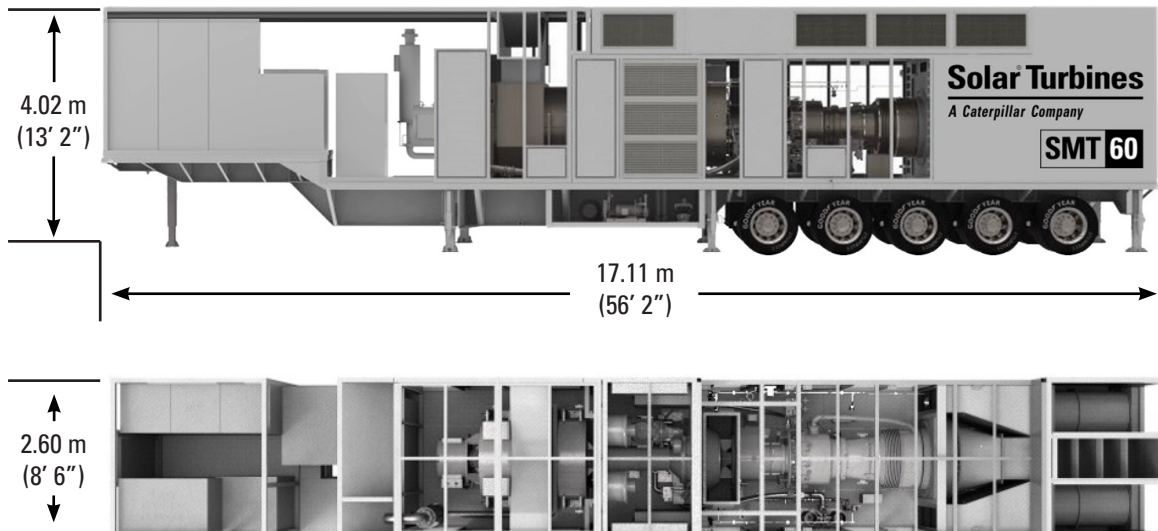

Package weight without tractor: 50 330 kg (110,960 lbs)

Additional Information:

Web: www.solarturbines.com

Email: infocorp@solarturbines.com

Phone: +1-619-544-5352