



# S Couplers

S60, S70, S80

## Technical Specifications

Not all attachments available in all regions. Consult your Cat® dealer for specific configurations available in your region.

### Table of Contents

Specifications .....	2
Dimensions .....	3
Matching .....	4

# S Couplers Technical Specifications

## Specifications

Model	Part Number	Linkage	Carrier Weight, Maximum	Permitted Positive Torque	Permitted Negative Torque	Weight		Lift Hook Capacity	
			ton	kN·m	kN·m	kg	lb	ton	lb
S60	573-3161	M312	18	150	75	174	384	5	10000
	573-3168	312	18	150	75	147	324	5	10000
	573-3166	315	18	150	75	176	388	5	10000
S70	566-2349	B/M320	30	300	195	259	571	8	16000
	566-2351	CB	30	300	195	285	628	8	16000
S80	573-3169	CB	40	600	390	426	939	10	20000
	573-3171	DB	40	600	390	456	1005	10	20000

# S Couplers Technical Specifications

## Dimensions

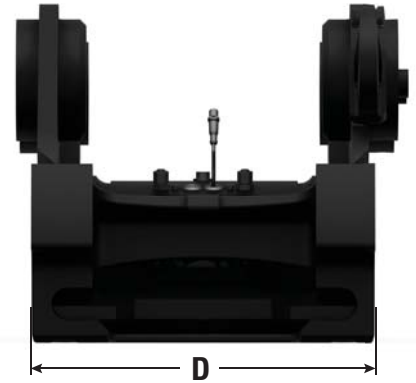
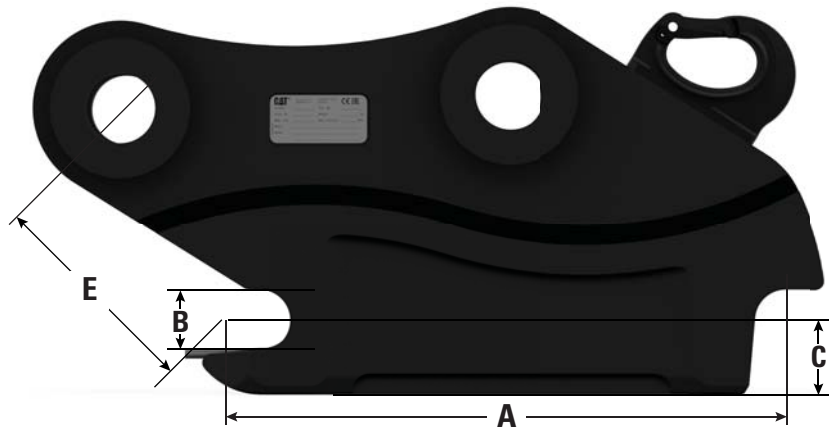

Model	Part Number	(A) Shaft Center to Center		(B) Shaft Diameter		(C) Height		(D) Width		(E) Hinge Distance	
		mm	in	mm	in	mm	in	mm	in	mm	in
S60	573-3161	480	18.9	60	2.4	75	3.0	340	13.4	245	9.6
	573-3168	480	18.9	60	2.4	75	3.0	340	13.4	225	8.9
	573-3166	480	18.9	60	2.4	75	3.0	340	13.4	235	9.3
S70	566-2349	600	23.6	70	2.8	85	3.3	450	17.7	290	11.4
	566-2351	600	23.6	70	2.8	85	3.3	450	17.7	295	11.6
S80	573-3169	670	26.4	80	3.1	108	4.3	590	23.2	295	11.6
	573-3171	670	26.4	80	3.1	108	4.3	590	23.2	315	12.4

# S Couplers Technical Specifications

## Matching

Match

No Match

	S60	S70	S80
<b>Tracked Excavators</b>			
313D2 GC	✓		
313D2	✓		
313F GC	✓		
313F	✓		
315F	✓		
316F	✓		
318D2	✓		
318F	✓		
320D2 GC		✓	
320D2		✓	
320D3		✓	
320 GC		✓	
320		✓	
323F		✓	
323		✓	
325F		✓	
326D2		✓	✓
326F		✓	✓
330D2		✓	✓
330F		✓	✓
330 GC		✓	✓
330		✓	✓
335F		✓	✓
336D2 GC			✓
336D2			✓
336D2 XE			✓
336F			✓
336F XE			✓
336 GC			✓
336			✓
340D2			✓
340F			✓
340			✓

	S60	S70	S80
<b>Wheeled Excavators</b>			
M314F	✓		
M315D2	✓		
M315F	✓		
M316F	✓		
M317D2	✓		
M317F	✓		
M318F	✓		
M320D2		✓	
M320F		✓	
M322D2		✓	
M322D2 MH*		✓	
M322F		✓	
M324D2 MH*		✓	
<b>Material Handlers</b>			
MH3022*		✓	
MH3024*		✓	
MH3026*		✓	

\*when equipped with linkage

For more complete information on Cat products, dealer services, and industry solutions, visit us on the web at [www.cat.com](http://www.cat.com)

GEJQ9382-00 (05-2019)  
(EU)

© 2019 Caterpillar  
All rights reserved

Materials and specifications are subject to change without notice. Featured machines in photos may include additional equipment. See your Cat dealer for available options.

CAT, CATERPILLAR, LET'S DO THE WORK, their respective logos, "Caterpillar Yellow," the "Power Edge" and Cat "Modern Hex" trade dress as well as corporate and product identity used herein, are trademarks of Caterpillar and may not be used without permission.

