

1204D-E44TTA

Industrial Engine

UN ECE R96 Stage IIIA/Brazil Mar-1
140 kW/187 hp

The Perkins® 1204D, the 4 cylinder option for the 1200 Series that gives you a complete power solution for UN ECE R96 Stage IIIA/Brazil Mar 1 emission standards. The choice of options, engine configurations and robust technology allows you to integrate the 1204 range into your equipment with minimum engineering.

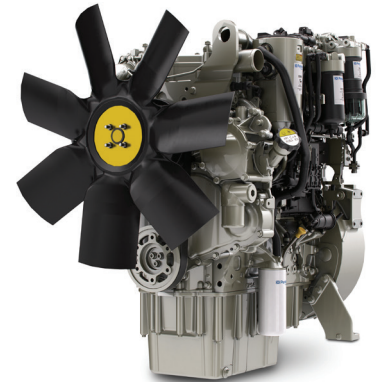

A lifetime of low cost

We have designed the Perkins®1204 range with optimised fuel consumption in mind, matching it to the operating cycles of a wide range of equipment and applications. Low cost maintenance is achieved through hydraulic tappets, multi-vee belts, service free aftertreatment and 500 hour oil change intervals. In addition, on the 1204D industrial engine, many service items can be located on either side of the engine to give you maximum access for servicing.

Downsizing opportunity

The high power density and excellent torque in our 1204 range allows you to select a more compact engine where previously you might have used an engine of a higher cubic capacity. This downsizing has several benefits, including saving you money and providing more space to package aftertreatment units.

Tailored for your machines

Your needs are our top priority, which is why we provide more tailored technology than anyone else. Working closely with OEMs, we have developed the 1204 range with hundreds of options so that it easily fits into your machine.

Our 1204 range engines come with two year warranties as standard and can also be supported by extended service contracts.

Specification	
Cylinders	4
Displacement litres	4.4
Aspiration	Series turbocharged aftercooled
Bore and Stroke mm (in)	105 x 127 (4.1 x 5)
Maximum Power kW (hp)	140 (187)
Rated Speed (rpm)	2200
Maximum Torque Nm (lb ft) @ rpm	825 (609) @ 1400
Combustion System	Direct injection
Weight kg (lb)	420 (926)
Rotation (viewed from flywheel)	Anti-clockwise

1204D-E44TTA

Industrial Engine

UN ECE R96 Stage IIIA/Brazil Mar-1

140 kW/187 hp

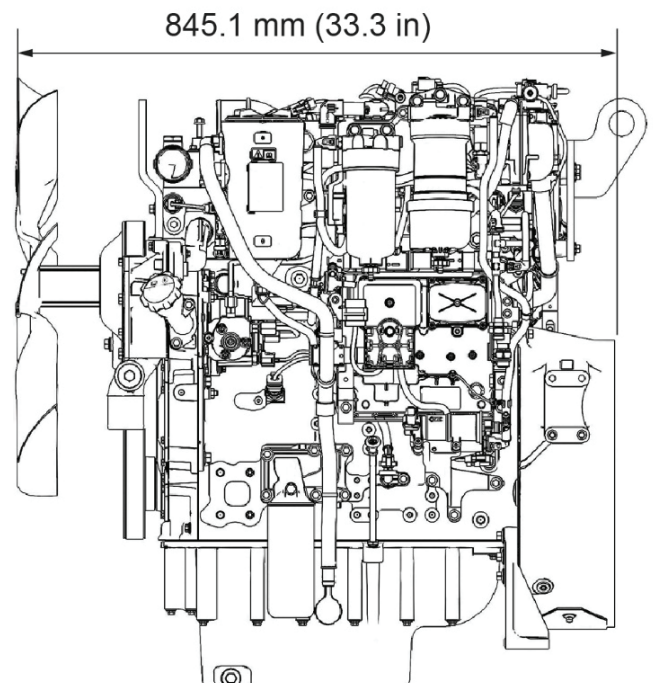
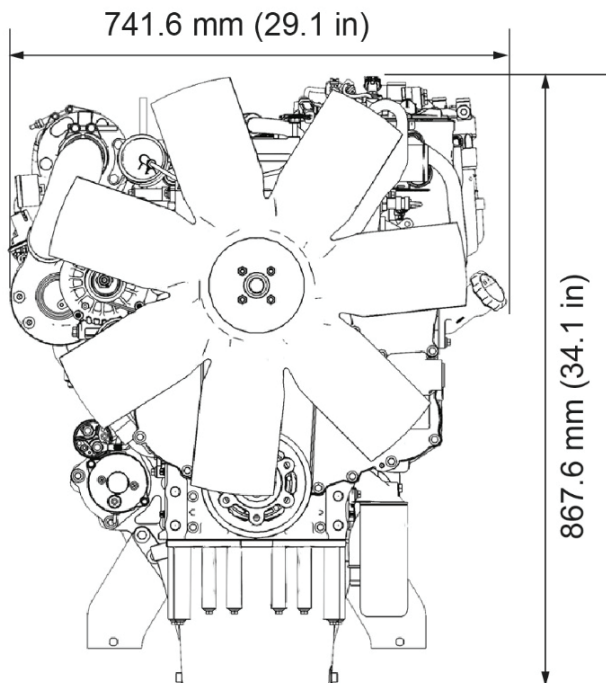
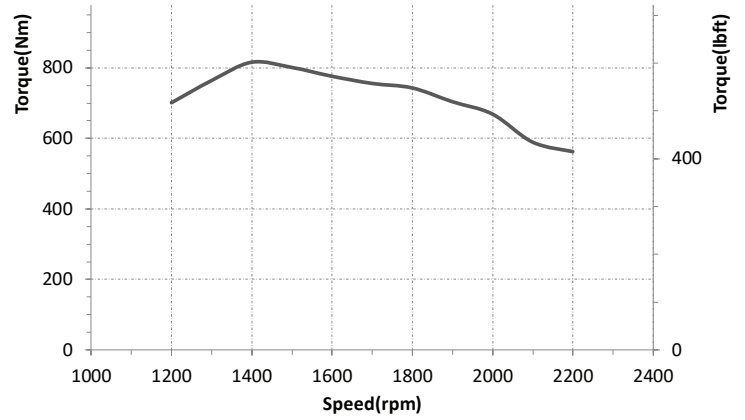
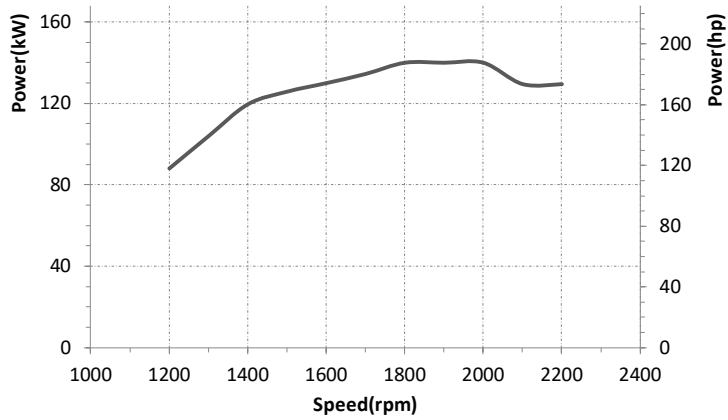

Photographs are for illustrative purposes only and may not reflect final specification.
All information in this document is substantially correct at time of printing and may be altered subsequently.
Final weight and dimensions will depend on completed specification.
Publication No. PN3209/02/19 Produced in England ©2019 Perkins Engines Company Limited