



CAT® THREE60 POD 650

Cat® Three60 Pod 650 is designed for the Cat C8.7 electronically controlled marine propulsion engine, providing unmatched response and performance.



JOYSTICK AND LEVER HEAD

The joystick and the lever head provide smooth operation and high confidence when maneuvering, using two modes:

THE LEVER MODE

- Controls the Pod propeller drive trains using the lever head.
- Pod vectoring is controlled by the digital steering helm.

THE JOYSTICK MODE

- Controls engine speed, gear, and Pod angle using intuitive fingertip movements of the joystick for slow vessel maneuvering.



ELECTRICAL SYSTEM

- Master controller (one per system).
- Powertrain controller (one per Pod).
- Digital lever control head and button panel (min. 1 – max. 3).
 - Standard top mount dual lever style
 - Optional Palm Beach style.
- Integrated digital steering helm (min. 1 – max. 3).
 - Three different steering wheel finishes.
- Digital joystick (min. 1 – max. 6).
 - Standard forward facing.
 - Optional aft facing.
- Integrated color touchscreen display (min. 1 – max. 6).

OPTIONAL:

- Interface to popular autopilot systems.



MECHANICAL SYSTEM

- Cat Three60 Pod 650:
 - 12 or 24 Volt system configurations.
 - 2.17:1 gear ratio.
 - Contra-rotating propellers.
 - Breakaway lower unit.
 - Replaceable nose cone and skeg.
 - Optional PTO.
- Multiple jackshaft lengths for flexible engine space installation.
- Engine water intake and shutoff.
- Equipped with quick-connect lube ports for easy oil service.



DIMENSIONS

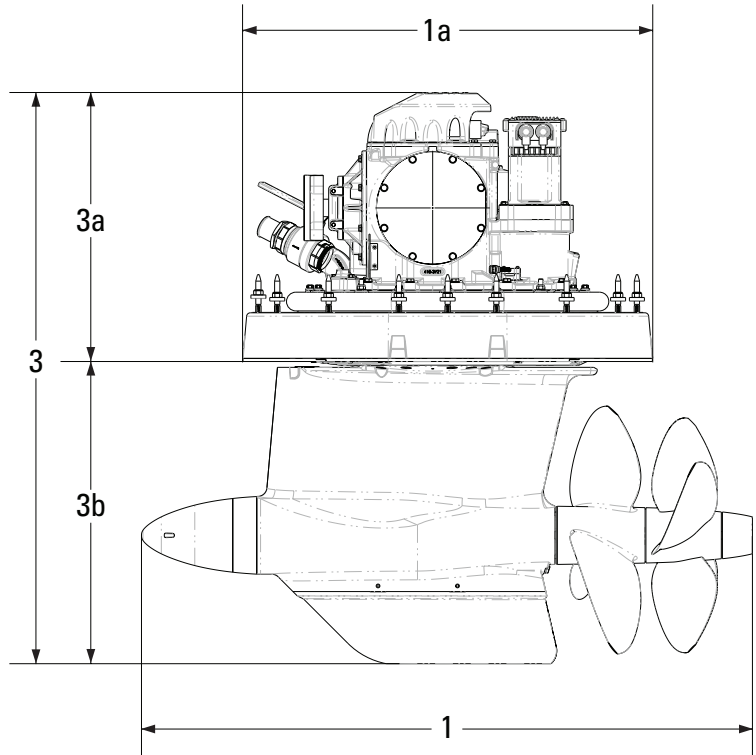
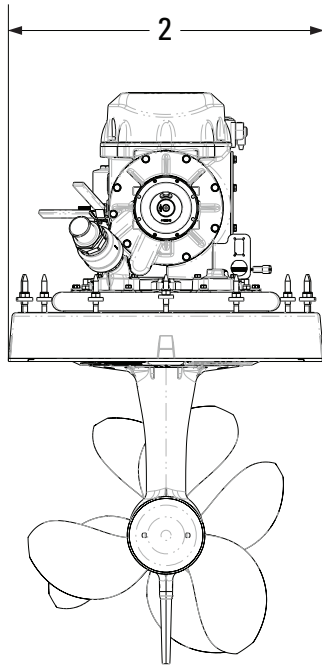

1	Length lower unit	1626 mm (64.0 in)
1a	Length hull seal area	1095 mm (43.1 in)
2	Width of hull seal area	841 mm (33.1 in)
3	Height overall	1656 mm (65.2 in)
3a	Height above hull seal	825 mm (32.5 in)
3b	Height below hull seal	832 mm (32.8 in)
Weight w/o Props		727 kg (1599 lb)
Total Package weight w/o Props/fluids		1825 kg (4022 lb)

PERFORMANCE DATA

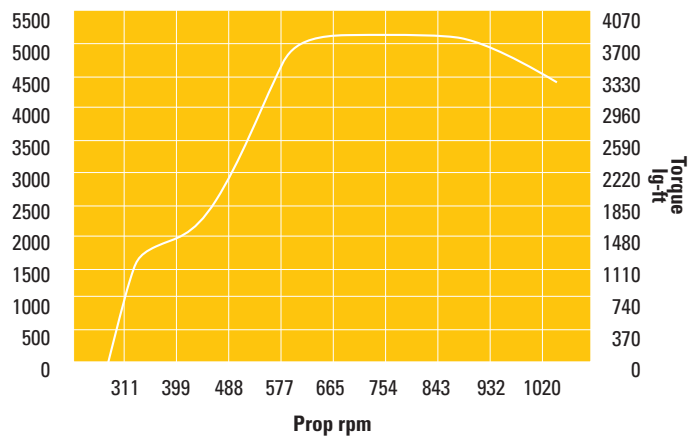

cat.com

© 2017 Caterpillar. All Rights Reserved. CAT, CATERPILLAR, BUILT FOR IT, their respective logos, "Caterpillar Yellow," the "Power Edge" trade dress as well as corporate and product identity used herein, are trademarks of Caterpillar and may not be used without permission.

