



**BUILT FOR IT.**

[cat.com](http://cat.com)

© 2016 Caterpillar. All Rights Reserved. CAT, CATERPILLAR, BUILT FOR IT, their respective logos, "Caterpillar Yellow," the "Power Edge" trade dress as well as corporate and product identity used herein, are trademarks of Caterpillar and may not be used without permission. LE2M0103-01



**MAKE  
THE  
HARBOR  
YOUR  
PLAYGROUND**

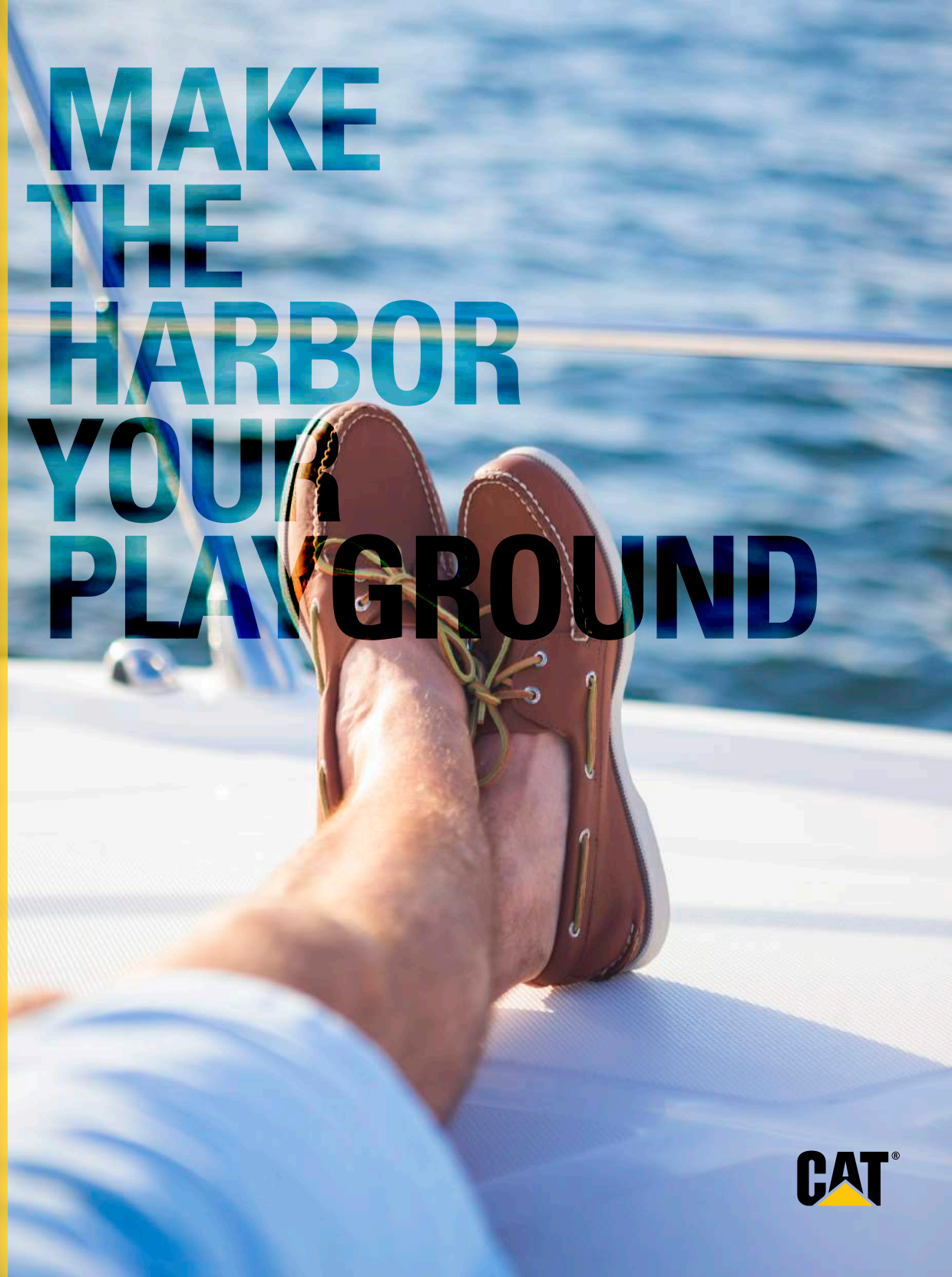



An aerial, top-down view of a city street grid. A river or canal runs through the center, with several boats docked along its banks. The buildings are multi-story and have various roof colors, including grey, brown, and blue. The streets are paved and have white crosswalks. The overall scene is a dense urban environment.

# WE'RE MAKING

At Caterpillar, we have a continuing commitment to provide integrated propulsion packages to our customers. That is why the procedure of creating our new pod solution for pleasure craft began years ago. At Caterpillar, we don't believe in creating just a great solution, we believe in creating the best solution.

We are now pleased to launch the new Cat® Three60 Pod 650 for pleasure craft.

# A STATEMENT



# FROM ENGINE TO PROPELLER

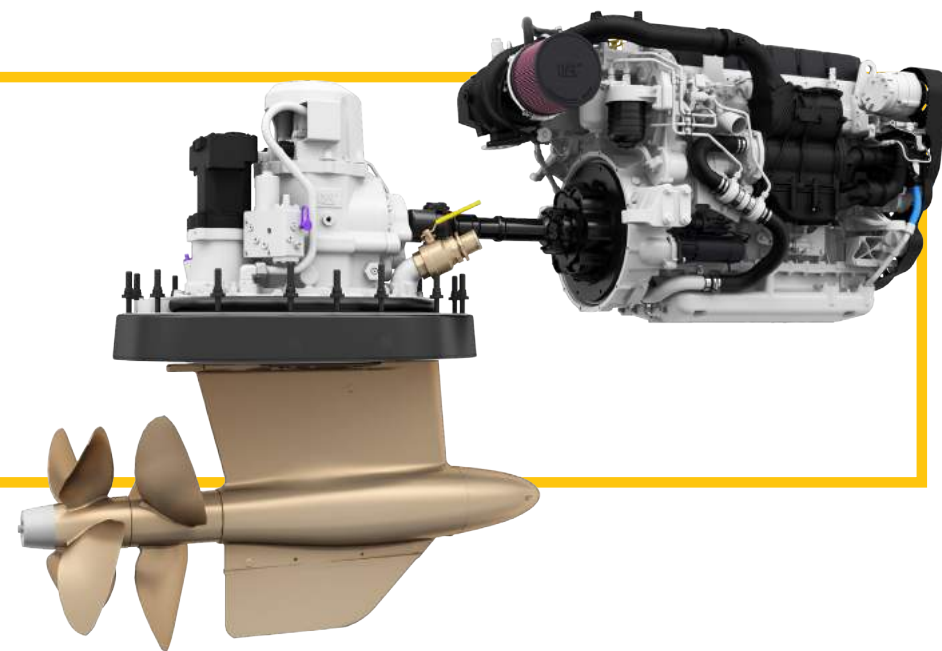

**T**he new Cat Three60 Pod 650 is part of a complete engine-to-propeller solution and represents our continuing commitment to provide integrated propulsion packages to our customers. Together with our world-renowned engines and control systems, the Cat Three60 Pod 650 makes docking and slow-speed maneuvering for diesel-powered yachts fun. The pod is specifically designed to be remarkably easy for customers to learn, with easy 'Push, Twist and Go' maneuvering.

It's designed specifically to match Cat Marine propulsion engine performance with Twin Disc® QuickShift™ technology integrated in the pod transmission to eliminate driveline shock. With larger propellers and deeper gear ratios, you get better performance and better fuel economy.



A close-up photograph of a boat's stainless steel cleat and a black rope against a blue sky background. The cleat is highly reflective, showing distorted reflections of the sky and surrounding environment. A black rope is attached to the cleat and extends towards the right. In the background, a green wooden post with a white rope tied around it is visible, along with a blurred cityscape under a clear blue sky.

“Push,  
Twist  
and Go.”



# TAKE THE CONTROLS



**O**ur new pod solution contains proprietary technology, providing seamless power transitions as well as smooth shifting from forward to reverse. The pod joystick and lever head provide smooth operation and high confidence when maneuvering, utilizing two modes: lever mode and joystick mode.

The lever mode controls the pod propeller drivetrains using the lever head, while pod vectoring is controlled by the digital steering helm.

In joystick mode, the joystick controls engine speed, gear and pod angle using intuitive fingertip movements of the joystick for slow vessel maneuvering.





# EXPERIENCE MATTERS

**W**hen you buy Cat products, you buy strength, reliability and trust. Strength is in our global dealer network. Wherever you go, our dealers are there to support you with anything and everything.

Caterpillar stands for reliability. That comes from centuries of experience of marine solutions from engines to propulsion. When you buy a product that says Cat, you buy trust. And now we will offer that same trust, but in a new and complete package to our pleasure craft customers.

With the introduction of the new Cat Three-60 Pod 650, we will also offer brand new engines and control systems for yachts in different sizes (35-70 ft.). With our Concierge service for yachts and our reputation in the industry, we know that you will feel confident in your choice.

# TECHNICAL SPECIFICATIONS



## MECHANICAL SYSTEM

- 12 or 24 Volt system configurations
- 2.17:1 gear ratio
- Contra-rotating propellers
- Breakaway lower unit
- Replaceable nose cone and skeg
- Optional PTO/PTI

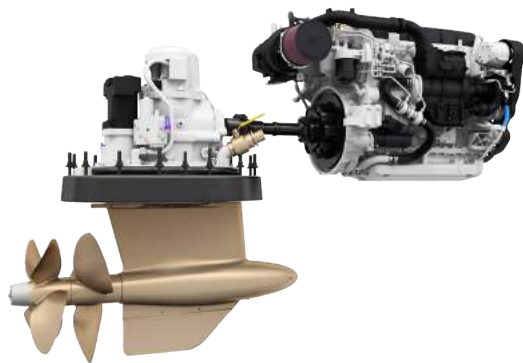

## EXTRA OPTION

- Interface to popular autopilot systems



35-50 FT

### THREE60 POD 507 – C7.1

Engine: C7.1  
Length: 35-50 ft.  
Bkw:373  
Bhp:500  
Mhp:507  
Speed: 20-40 knots



35-60 FT

### THREE60 POD 650 – C8.7

Engine: C8.7  
Length: 35-60 ft.  
Bkw:478  
Bhp:641  
Mhp:650  
Speed: 20-40 knots



50-70 FT

### THREE60 POD 1000 – C12.9

Engine: C12.9  
Length: 50-70 ft.  
bkw:735  
bhp:985  
mhp:1000  
Speed: 20-40 knots



# AT YOUR SERVICE



To make any nautical adventure possible you have to rely on your equipment to never fail you. With our new world-class engines for 35-70 ft. yachts and our refined control systems for the Cat Three60 Pod 650, you get a complete engine-to-propeller solution that makes every day at sea joyful.

Caterpillar Marine products go hand in hand with a worldwide marine support network that includes CAT dealers plus hundreds of authorized marine dealers. This network combines experience and expertise, products and services, backup and support. Our focus is on you so that you can focus on making every harbor your playground.