

CAT® UNDERCARRIAGE

ALL THE RIGHT CHOICES

Options to match your application and underfoot conditions



MEDIUM TRACK-TYPE TRACTORS



MORE THAN THE RIGHT CHOICE... THE BEST CHOICE.

Every customer, every job, every machine—every choice you make has multiple impacts. Your success rides on looking at the possibilities and choosing what delivers the best productivity, durability and value in a given application.

We offer more undercarriage options for your Cat® machines than any other manufacturer because we know that the more precisely you match iron to application, the more effective and efficient your work will be. And, that builds a stronger bottom line.

Every Cat Undercarriage is designed by Caterpillar engineers and built to exacting specifications based on the real-world experience of our customers. So, when you choose a Cat Undercarriage, you know it's not just the right choice, it's the best choice.

BUILT FOR IT.™





CAT®

UNDERCARRIAGE SELECTION MATTERS

One of the most important factors in helping you achieve the lowest owning & operating costs and maximizing equipment uptime is matching the right undercarriage option to your specific machine model and work application.

Your Cat dealer has the undercarriage knowledge and selection tools to help ensure you choose the best option for your equipment and your job. When consulting with you on options, dealers use these tools while taking key factors into account to identify your best-fit undercarriage configuration.

Key Selection Factors to Consider

Track Frame Configuration	Standard, Extended (L) (XL), Extra Wide (XW), Low Ground Pressure (LGP)
Width of Track Shoes	Narrow, intermediate or wide Tri- and Quad-link Track configurations
Type of Track Shoe	Extreme Service (ES), Moderate Service (MS), Self-Cleaning, Center Hole, Chopper
Blade Type	Variable-pitch Power Angle/Tilt (VPAT), Semi-Universal (SU), Angle, Straight
Rear Attachment	Winch, Ripper, Counterweight, Drawbar
Other Attachments	Sweeps, Window Guarding
Underfoot Conditions	Light, moderate or severe abrasion and impact
Terrain	Side slopes, ground objects and V-ditching
Packing Conditions	Operating in extrusive materials, which can usually be squeezed out from between track parts when wet, e.g., clay soils Operating in non-extrusive materials, which can't be extruded from the link windows and track shoe center holes of most undercarriage tracks, e.g., branches



UNDERCARRIAGE APPLICATION GUIDE

Life/Impact Matrix

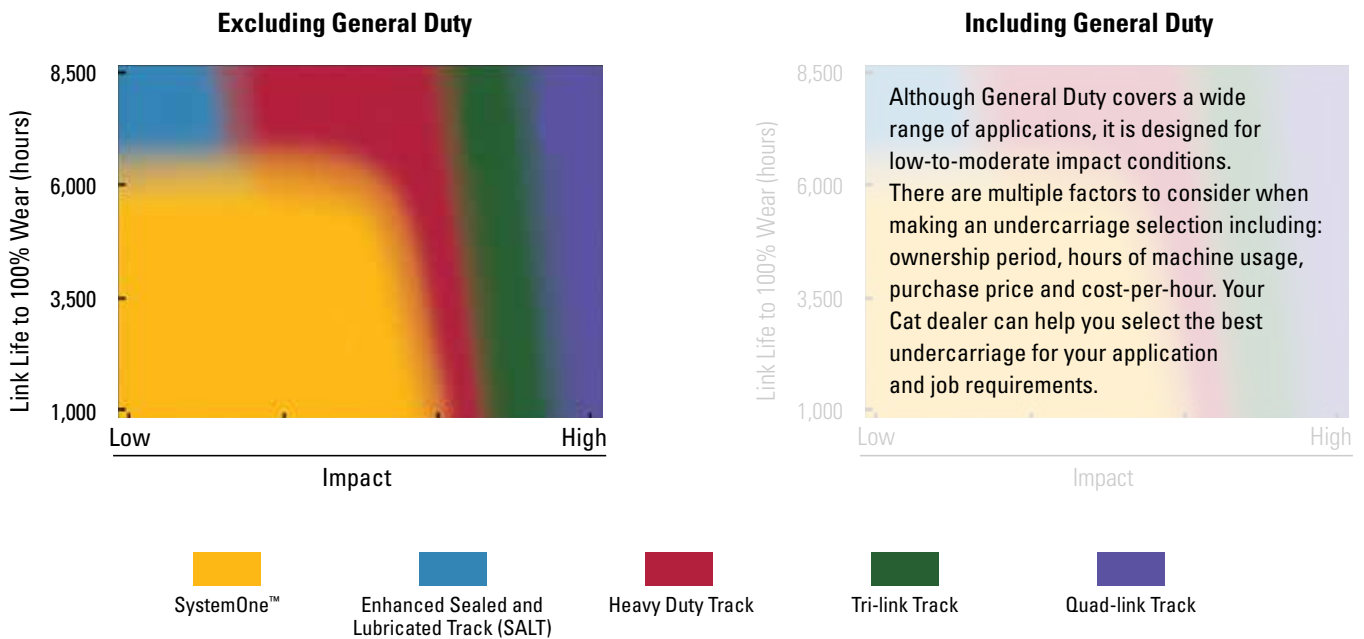

FIND THE RIGHT UNDERCARRIAGE

We've been helping customers find the best undercarriage for their job requirements for over a century—longer than anyone else in the business. Our customers get the benefits of that experience.



WHAT IS THE BEST FIT FOR YOU?

Your work experience is the most important element in selecting undercarriage to meet the demands of your business and your budget. To choose the Cat Undercarriage that's just the right fit for your work and your machine, you have to ask questions:

- How long will I own this machine?
- How many hours a week will I be using this machine?
- What are my typical ground/soil conditions?
- What are my impact conditions?
- What attachments are on my track-type tractor?
- What are the grades/slopes on my job site?

The more precisely you define these parameters, the more effective your choice will be.

Cat Track Options	Track Loader Compatibility			Track-Type Tractor Compatibility		
	953	963	973	D6	D7	D8
System One	•	•		•		
Heavy Duty				•	•	
Heavy Duty Extend Life with Dura Link						•
General Duty		•	•	•	•	•
PPR						•
Tri/Quad				•		

CAT SYSTEMONE UNDERCARRIAGE

THE LEADER IN LOWERING O&O COSTS

The goal behind Cat SystemOne Undercarriage: Develop a durable and reliable undercarriage that works and wears as a system, ensuring a balanced wear life to significantly lower customers' O&O costs. SystemOne is designed to increase undercarriage uptime and productivity, and longer service life, while it also reduces maintenance intervals and repair costs.

From its inception, SystemOne has delivered on its goal by routinely cutting customers' O&O costs. But performance success hasn't stopped us from constantly improving SystemOne—to help keep improving your productivity and profitability.



CONTINUOUS IMPROVEMENT

Caterpillar engineers have made many design enhancements to develop the superior SystemOne iron we're using today, particularly in the link assemblies. Overall, we have improved our design, manufacturing processes and materials used for application recommendations.

Take a look at these examples of major SystemOne design and manufacturing improvements. Caterpillar is committed to continuous improvement so you can be assured we'll never stop making SystemOne better for you.

Dry Joint Protection

- Increased the bushing strength to resist bushing cracking
- Redesigned the seal cavity, which allows seals to stay in their correct position and defends against the seal rolling under and packing
- Incorporated harder cartridge inserts to minimize endplay generation and thrust ring damage, which keeps oil where it belongs

Seal Exposure Reduction

- Cambered pivot shafts on LGP machines reduce thrust bias wear and provide better track alignment and less seal exposure throughout the life of the system
- Added a Relieved Tread Idler (RTI) to better resist thrust wear and reduce material packing in the track seal cavity

Idler and Sprocket Life

- As in the original design, idler and sprocket segments are manufactured for reuse, so they typically last for up to two track systems (varying by model, application and underfoot conditions)

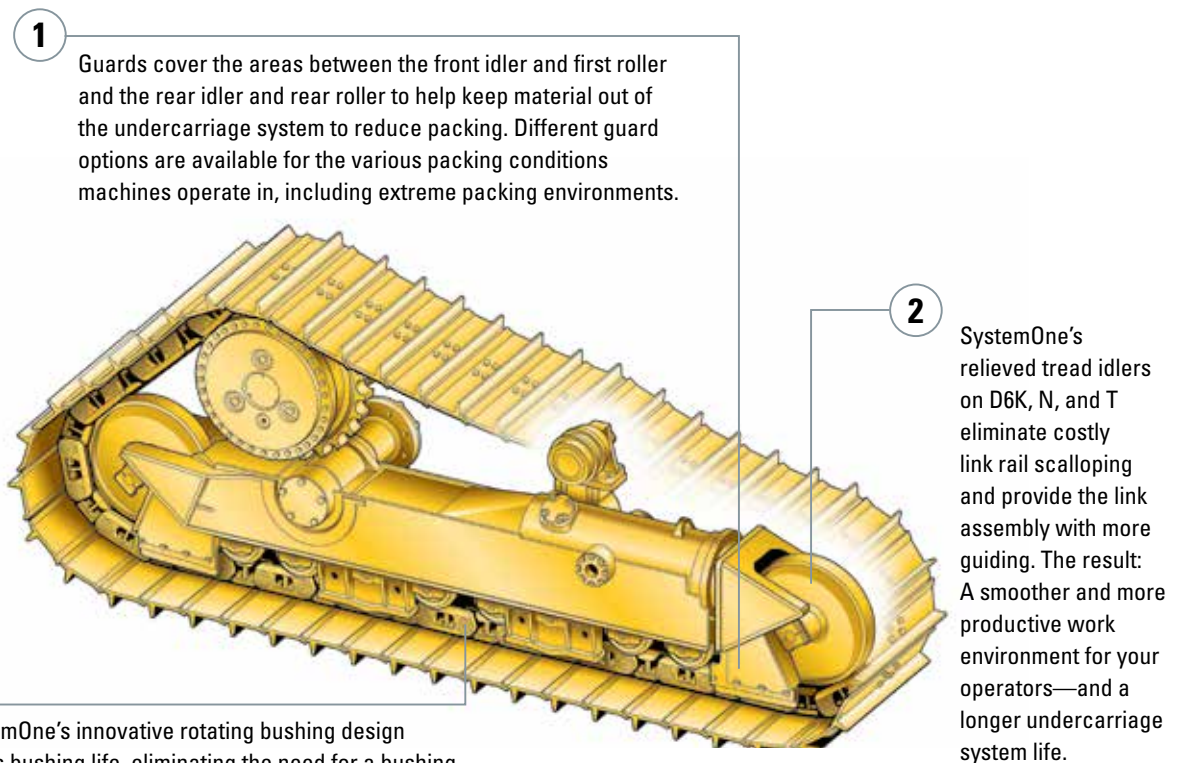

CAT SEALED AND LUBRICATED TRACK (SALT)

OPTIONS THAT FIT YOUR WORK

Cat Sealed and Lubricated Track (SALT) seals lubricant into your undercarriage system and keeps abrasives out. It virtually eliminates internal pin and bushing wear to reduce maintenance costs and downtime, while increasing service life and serviceability.

Cat SALT offers you a universal undercarriage configuration for a wide range of underfoot conditions when coupled with the track design that matches your machine and operating environment.



TRACK DESIGN VARIATIONS

Heavy Duty Track (HD)

For medium track machines with an elevated sprocket design (D6N, D6T), Heavy Duty is the choice for top performance and long life in demanding applications. Heavy Duty components are built with high grade steel and through hardened for exceptional strength and wear life.

General Duty Track (GD)

Designed for use in low-to-moderate impact applications where the elevated performance of Heavy Duty is not needed, General Duty rounds out the portfolio for Cat medium-size machines. Like all genuine Cat Undercarriage, General Duty components are through hardened and quality tested for reliable productivity and performance.

ENHANCEMENTS REDUCE O&O COSTS

Since introducing SALT in 1974, Caterpillar has consistently enhanced its design to meet the specific needs of your applications. Each track component has undergone and continues to undergo our stringent improvement process, so your undercarriage will work harder for you.

As a result, SALT offers major advantages, all of which add up to longer wear life—and reduced O&O costs for you.

- Sophisticated heat-treat processes ensure track links have high core hardness, helping to hold the track section together and preventing leaks caused by links “walking off” the pin.
- Cross-drilled pins provide an oil passage between the pin and the bushing. Carefully machined oil reservoirs ensure proper oil distribution.
- Polished bushing ends prevent accelerated seal lip wear. Stepped bushings, which are thicker in the middle, provide more external wear material.
- Rigid seal, which consists of a flexible load ring, rigid seal ring and thrust ring, provides better sealability in all underfoot conditions, reducing the effects of impact on track joints that can cause premature seal failure.

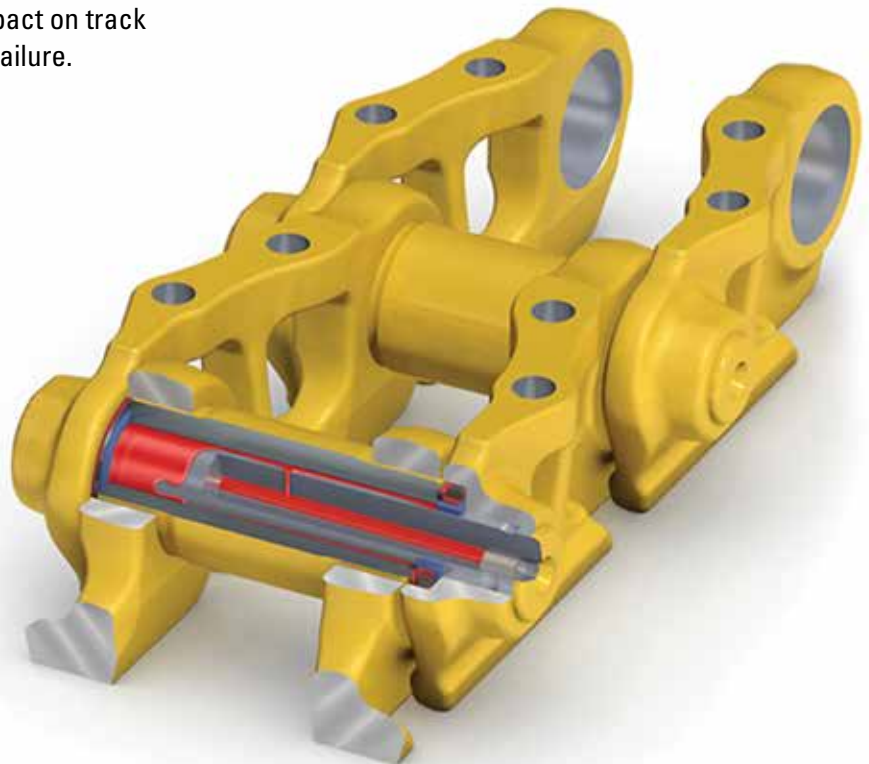

CAT HEAVY DUTY TRACK

TOUGH TRACK FOR TOUGH JOBS

Specifically engineered to match the requirements of medium-size machines with an elevated sprocket operating in demanding work environments, Cat Heavy Duty Track is much more than just another version of conventional Cat Sealed and Lubricated Track (SALT).

In most tough underfoot conditions, Heavy Duty Track can extend your undercarriage system life up to 20 percent more than Cat General Duty, with the greatest benefits realized in aggressive, high-impact applications such as:

- Logging/reforestation
- Side-sloping work
- Rocky conditions
- Any uneven terrain with wide track shoes (specifically Low Ground Pressure (LGP) machines)

Heavy Duty Track Compared to General Duty Track

Component	Benefit
Links	<ul style="list-style-type: none"> • Greater bushing retention • Deeper heat-treat • Increased strength
Bushing	<ul style="list-style-type: none"> • Increased retention
Pin	<ul style="list-style-type: none"> • Increased retention

Results may vary based upon application.

POSITIVE PIN RETENTION (PPR) TRACK

DESIGNED FOR MAXIMUM TRACK LIFE

PPR Track features specially machined links and pins that allow for the use of a metal retaining ring. This ring is pressed into the groove between the pin and link, locking the joint to a predetermined factory end-play specification.

- Prevents end-play generation (the outward movement of the links on the pin)
- Ensures oil retention in high-impact conditions

This exclusive Caterpillar design is recommended for applications that generate high impact loading such as mining, heavy construction, demolition, and waste disposal. Machines equipped with wider shoes, Extreme Service shoes, or Super Extreme Service shoes should also consider PPR Track.

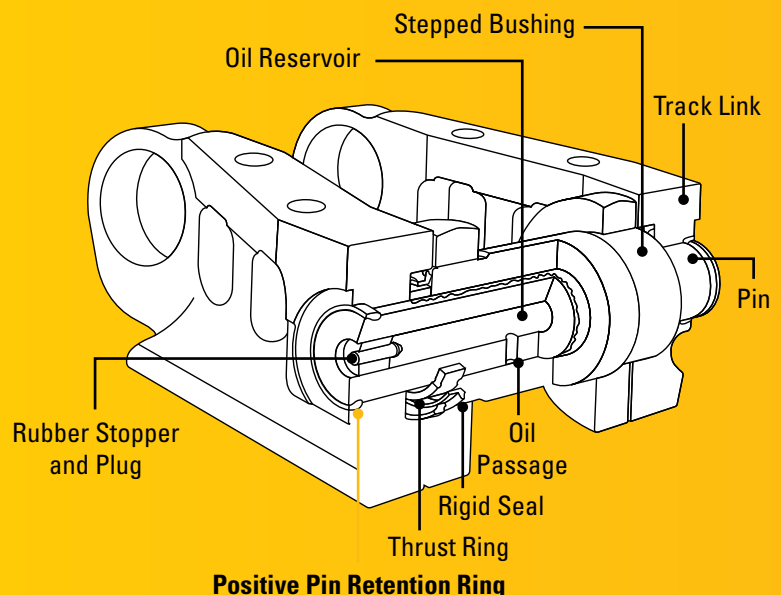

CAT GENERAL DUTY TRACK

PERFORMANCE YOU CAN COUNT ON

We recommend General Duty Undercarriage for your low-to-moderate impact applications where the elevated performance of the Cat Heavy Duty Undercarriage is not needed.

- While General Duty is built to different specifications than Heavy Duty, its design makes General Duty and Heavy Duty components interchangeable, eliminating any need for retrofitting and keeping downtime to a minimum. Cat Heavy Duty shoes can be installed on General Duty link assemblies to meet various customer requirements.
- Your dealer has excellent General Duty parts availability for fast turnaround time. General Duty Track Groups are stocked.
- General Duty offers a variety of track shoe options. In addition to undercarriage components, track shoe selection can impact traction and flotation as well as overall undercarriage wear life. For the conditions in which General Duty undercarriage will typically operate, moderate service shoes offer optimal performance and wear life. (General Duty moderate service shoes for track-type tractors will be available in preassembled track groups.)
- General Duty is covered by Cat Undercarriage Assurance. Ask your Cat dealer for details.

CAT TRI-LINK & QUAD-LINK TRACK

DESIGNED FOR THE EXTREME

Tri-Link Track and Quad-Link Track were developed by Caterpillar as undercarriage solution options for the most severe impact conditions. Their unique designs improve link assembly strength by bolting on additional outrigger chains, making them the right choice for logging (skidding), stumping and taking on work in rocky terrains or any application where shoe deflection is high.

Tri-Link Track adds one outrigger chain to the outer ends of the track shoes, and Quad-Link Track adds two, which greatly improves sealability and structural performance.

Using Tri-Link Track or Quad-Link Track in high-impact applications may at first seem more expensive, but the reality is tough tracks typically result in lower undercarriage cost-per-hour because they were designed for extreme conditions and offer you better load distribution, improved lubricated joint life (fewer dry joints) and greater system reliability.

NOTE: Tri-Link Track and Quad-Link Track are available only with the Heavy Duty Track option.

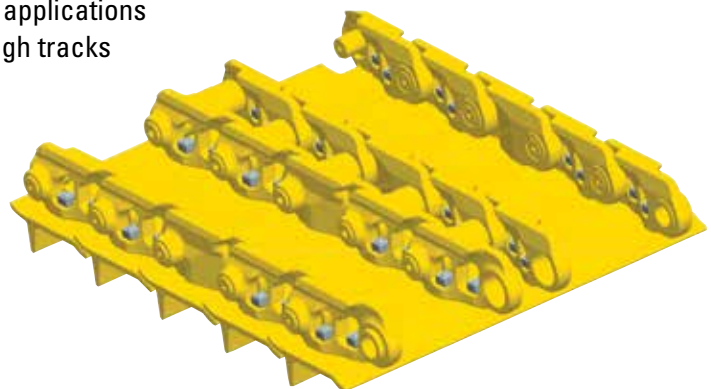

COMPREHENSIVE SUPPORT

To help you get the most from your Cat Undercarriage, Caterpillar and Cat dealers also remain dedicated to providing you with global service and support for all undercarriage configuration options—from advanced diagnostics to worldwide parts delivery.



UNDERCARRIAGE AND WEAR LIFE ASSURANCE PROGRAMS

Our Undercarriage Assurance Programs were developed to demonstrate our commitment to provide you the lowest cost-per-hour undercarriage systems. Assurance Programs offer you support beyond the standard new machine or parts warranties. They cover all major moving undercarriage components on Cat Track-Type Tractors, Track-Type Loaders and Track-Type Hydraulic Excavators. See your Cat dealer for full details about coverage for specific undercarriage configuration options.

	Coverage in Years	Coverage in Hours	Coverage in Percent Worn
General Duty	4	3,000	100%
Genuine	4	4,000	100%
Gold	4	6,000	100%
SystemOne	4	6,000	100%

*Stipulations Apply

CUSTOM TRACK SERVICE (CTS)

An improperly managed undercarriage can account for more than half of machine maintenance costs. That's why we provide Custom Track Service (CTS), our comprehensive program for managing your undercarriage system, which uses the most advanced diagnostic equipment available, like the Ultrasonic Wear Indicator.

With CTS, we can accurately monitor undercarriage performance and predict wear rates, so you can evaluate service options, plan your maintenance and schedule downtime. Overall, CTS analysis, which can be completed on your job site, helps you make informed decisions that keep your operating costs as low as possible.

WORLDWIDE PARTS AVAILABILITY

Our industry-standard parts distribution network makes most new parts available to you anywhere in the world, usually within 24 hours.

CONSULT WITH YOUR CAT DEALER TODAY

Your Cat dealer has the undercarriage expertise and selection tools to assist in assessing your undercarriage configuration options. So you'll want to consult with your dealership to verify which option is the right undercarriage choice for you. The choice that best suits your machine and application, and also offers you the right fit to meet your owning and operating needs.

PEDJ0100-04
www.cat.com

© 2016 Caterpillar. All Rights Reserved

CAT, CATERPILLAR, their respective logos, SystemOne™, "Caterpillar Yellow" and the "Power Edge" trade dress, as well as corporate and product identity used herein, are trademarks of Caterpillar and may not be used without permission.

