



Cat[®] 773E

OFF-HIGHWAY TRUCK

FEATURES:

- **Power Train** – Cat[®] 3412E air-to-air after cooled diesel engine features Hydraulic Electronic Unit Injector (HEUI™) for efficient operation. High displacement/low speed rating extends engine life. Cat 3412E meets U.S. EPA Tier 2 equivalent/China Nonroad Stage III emission standards. The 19% torque rise provides high lugging force during acceleration and less down shifting on grade or in rough underfoot conditions. The torque rise effectively matches the transmission shift points to provide maximum efficiency and faster cycle times.
- **Fuel Economy** – The 773E fuel saving strategies find opportunities to reduce fuel burn and fuel costs.
 - Economy Mode modifies engine maps to take advantage of steady grades and level ground, reducing power and fuel burn.
 - Speed Limiting automatically selects the most fuel efficient gear and speed for the terrain at each moment.
 - Engine Idle Shutdown identifies when the truck is in park and idles for more than a preset time, and initiates engine shutdown to conserve fuel. This feature can be time adjusted or turned on or off according to your specific needs.
 - Engine Over Speed Protection – Electronically senses engine conditions and automatically up-shifts one gear to prevent over speeding. For machines with ARC, if over speeding occurs in the top gear, the lock-up clutch is disengaged, and the brakes are applied.
- **Serviceability** – The improved accessibility for radiator coolant and engine oil fill point improves serviceability. Safe, convenient maintenance with a machine platform and ground level battery disconnect. The new instrumentation and Advisor system provides a 3-category warning system and quick access to stored diagnostic data. The Advisor provides quick on-board diagnostics, reduces downtime and lowers operating costs. Radial seal filters are easy to change, and vertical, spin-on filters simplify servicing. Quick coupler taps and S-O-SSM analysis points make oil sampling quick and clean. Sealed electrical connectors lock out dust and moisture. Color-coded wiring is standard.
- **Diagnostic Capability** – Critical power train data, including transmission shifting, engine speed and fuel consumption, provides service technicians with enhanced diagnostic capability to reduce downtime and operating costs.
- **Electronic Technician (ET)** – Cat ET service tool provides service technicians with easy access to stored diagnostic data through the Cat Data Link.
- **Cab and Access** – The 773E cab interior, is completely redesigned to provide better visibility and comfort for the operator. Features include a new dash, advisor display and redesigned center console. Rollover and Falling Object Protection is an extension of the truck frame.
- **Operator Seat** – The Cat Comfort Seat uses full air suspension to smooth rough rides, and has a retractable four-point seat belt with a shoulder harness. A trainer seat with a lap belt to facilitate on-the-job task training.
- **Brakes** – The Cat front dry caliper with rear oil-cooled multiple disc brakes deliver reliable performance and control in the most extreme haul-road conditions. Speed limiting during body up operation is standard. Oil-cooled rear disc brakes are designed and built for reliable, adjustment-free operation providing superior performance and service life in comparison to shoe-type and dry-disc systems. The system combines service, retarding and parking brake functions in a single unit.
- **Automatic Retarder Control (ARC) (optional)** – ARC controls braking on grade electronically, maintaining consistent engine speed, lower fuel burn, and better control.
- **Traction Control System (TCS) (optional)** – The traction control system monitors wheel slips so if it exceeds the set limit, the oil cooled disc brakes are automatically applied to slowdown the spinning wheel.
- **Steering** – Cat integrated steering and suspension system is designed for precise steering, excellent maneuverability, minimal tire wear and superior ride control. Secondary steering automatically engages if power source for the normal steering fails.
- **Durability** – Rear wheel spindles are solid steel for longer life, and the rear cylinders are inverted to protect the rods from debris. These rugged cylinders use large diameter bore and low pressure nitrogen/oil design for long life with minimal maintenance.

773E Off-Highway Truck

Engine

Engine Model	Cat 3412E	
Rated Engine Speed	2,000 rpm	
Gross Power – SAE J1995	567 kW	760 hp
Net Power – SAE J1349	537 kW	720 hp
Number of Cylinders	12	
Peak Torque	3436 N·m	2,534 lb ft
Torque Rise	19%	
Bore	137 mm	5.4 in
Stroke	152 mm	6.0 in
Displacement	27 L	1,649 in ³

- These engine ratings apply at 2,000 rpm when tested under the specified condition for the specified standard.
- Power rating conditions based on standard conditions of 25° C (77° F) and 99 kPa (29.32 in Hg) dry barometer, using 35° C (95° F) API gravity fuel having an LHV of 42 780 kJ/kg (18,390 Btu/lb) when used at 30° C (86° F) (reference a fuel density of 838.9 g/L [7.001 lb/gal]).
- Net power advertised is the power available at the flywheel when the engine is equipped with fan, air cleaner, muffler and alternator.
- No derating required up to 2300 m (7,500 ft) altitude.
- Meets Tier 2 equivalent/China Nonroad Stage III emission standards.

Transmission

Forward 1	9.9 km/h	6.2 mph
Forward 2	13.9 km/h	8.6 mph
Forward 3	18.8 km/h	11.7 mph
Forward 4	25.2 km/h	15.7 mph
Forward 5	34.1 km/h	21.2 mph
Forward 6	45.9 km/h	28.5 mph
Forward 7	62.2 km/h	38.6 mph
Reverse	13.1 km/h	8.1 mph

- Maximum travel speeds with standard 24.00R35 (E4) tires.

Final Drives

Differential Ratio	3.64:1	
Planetary Ratio	4.8:1	
Total Reduction Ratio	17.48:1	

- Planetary, full floating.

Brakes

Brake Surface – Front	1395 cm ²	216 in ²
Brake Surface – Rear	61 269 cm ²	9,496 in ²

- Meets ISO 3450: 2011 standards up to 99 300 kg (219,000 lb) gross operating weight.

Body Hoists

Pump Flow – High Idle	491 L/min	130 gal/min
Relief Valve Setting – Raise	17 225 kPa	2,500 psi
Relief Valve Setting – Lower	3445 kPa	500 psi
Body Raise Time – High Idle	9.5 seconds	
Body Lower Time – Float	12.5 seconds	
Body Power Down – High Idle	17.51 seconds	

- Twin, two-stage hydraulic cylinders mounted inside the main frame; double acting cylinders in second stage.
- Power raise in both stages and power down in second stage.

Capacity – Dual Slope – 100% Fill Factor

Struck	26.6 m ³	34.8 yd ³
Heaped 2:1 (SAE)	35.2 m ³	46 yd ³

Weight Distributions – Approximate

Front Axle – Empty	46.6%
Front Axle – Loaded	33.8%
Rear Axle – Empty	53.4%
Rear Axle – Loaded	66.2%

Suspension

Effective Cylinder Stroke – Front	234 mm	5.2 in
Effective Cylinder Stroke – Rear	149 mm	5.9 in
Rear Axle Oscillation	8.1°	

Sound

Sound Standards	ISO 6393:2008, SAE J1166:2008
-----------------	----------------------------------

- The operator sound exposure Leq (equivalent sound pressure level) measured according to work cycle procedures specified in SAE J1166:2008 is 80 dB(A) for cab offered by Caterpillar, when properly installed and maintained and tested with doors and windows closed.
- The dynamic operator sound pressure level is 80 dB(A) as per ISO 6396:2008 for cab offered by Caterpillar. When properly installed and maintained and tested with doors and windows closed.
- Hearing protection may be needed when operating with an open operator station and cab (when not properly maintained or doors/windows open) for extended periods or in a noisy environment.

Steering

Steer Angle	31°	
Turning Diameter Front Wheel Track	22 m	72 ft 2 in
Turning Circle Clearance Diameter	25 m	82 ft 0 in

- Steering Standards Steering Standards Meets SAE J1511 FEB94 and ISO 5010:2007.
- Separate hydraulic system prevents cross contamination. Steering wheel effort is low and steering wheel cycle times are reduced with a new variable-displacement, piston type steering pump.

ROPS

- ROPS (Rollover Protective Structure) for cab offered by Caterpillar meets ISO 3471:2008.
- FOPS (Falling Objects Protective Structure) meets ISO 3449:2005 Level II FOPS criteria.

Tires

Standard Tire 24.00R35 (E4)

- Productive capabilities of the 773E truck are such that, under certain job conditions, TKPH (TMPH) capabilities of standard or optional tires could be exceeded and, therefore, limit production.
- Caterpillar recommends the customer evaluate all job conditions and consult the tire manufacturer for proper tire selection.

Service Refill Capacities

Fuel Tank	700 L	185 gal
Cooling System	122 L	32 gal
Crankcase	68 L	18 gal
Differentials and Final Drives	155 L	41 gal
Steering Tank	34 L	9 gal
Steering System (includes tank)	60 L	16 gal
Torque Converter/Brake/ Hoist Hydraulic Tank	133 L	35 gal
Brake/Hoist System (includes tank)	307 L	81 gal
Torque Converter/Transmission System	53 L	14 gal
Torque Converter/Transmission System (includes sump)	72 L	19 gal

Dimensions (All dimensions are approximate.)

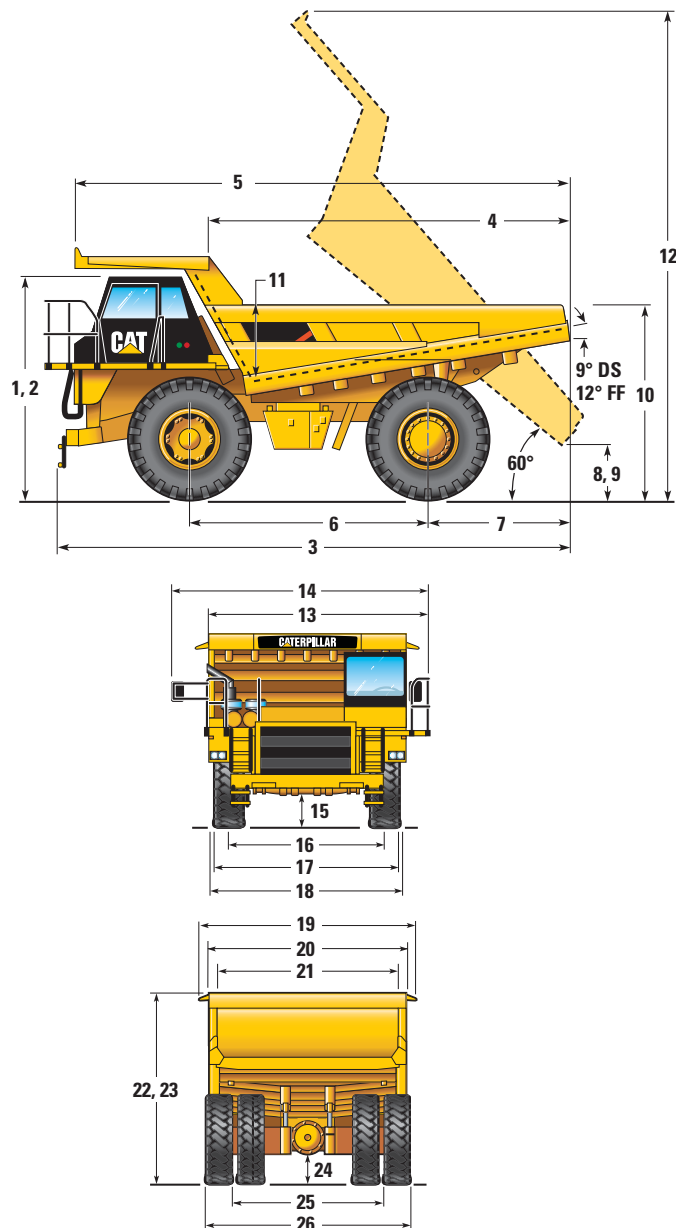

		Dual Slope Floor	
1	Height, Top of ROPS, Empty	4000 mm	13 ft 2 in
2	Height, Top of ROPS, Loaded	3900 mm	12 ft 10 in
3	Length, Overall	9338 mm	30 ft 8 in
4	Length, Inside Body	6400 mm	21 ft
5	Length, Overall Body	8535 mm	28 ft
6	Wheelbase	4191 mm	13 ft 9 in
7	Rear Axle to Tail	2782 mm	9 ft 2 in
8	Ground Clearance	676 mm	2 ft 3 in
9	Dump Clearance, Empty	566 mm	1 ft 11 in
10	Height, Loading, Empty	3773 mm	12 ft 5 in
11	Depth, Inside Body, Maximum	1840 mm	6 ft 4 in
12	Height Overall, Body Raised	8787 mm	28 ft 10 in
13	Width, Left Railing to Right Side Body	4316 mm	14 ft 2 in
14	Width, Operating	5076 mm	16 ft 10 in
	Width, Operating (with extended catwalk)	5539 mm	18 ft 2 in
15	Engine Guard Clearance	667 mm	2 ft 2 in
16	Width, Front Tire Center Line	3275 mm	10 ft 9 in
17	Width, Outside Front Tires	3966 mm	13 ft
18	Width, Cab	4040 mm	13 ft 5 in
19	Width, Overall Canopy	4398 mm	14 ft 5 in
20	Width, Outside Body	3910 mm	12 ft 10 in
21	Width, Inside Body	3658 mm	12 ft
22	Height, Front Canopy, Empty	4393 mm	14 ft 5 in
23	Height, Front Canopy, Loaded	4350 mm	14 ft 4 in
24	Rear Axle Clearance	591 mm	1 ft 11 in
25	Width, Rear Dual Tire Center Line	2927 mm	9 ft 7 in
26	Width, Overall Tire	4457 mm	14 ft 8 in

773E Off-Highway Truck

STANDARD EQUIPMENT

POWER TRAIN

- Cat 3412E HEUI engine
 - 12 cylinder diesel
 - Air-to-air aftercooler (ATAAC)
 - Hydraulic electronic unit injection
 - Air cleaner with precleaner (2)
 - Automatic cold mode idle control
 - Turbocharger (2)
- Braking system
 - Oil-cooled, multiple disc (rear)
 - Parking/secondary
 - Caliper disc (front)
 - Manual retarder (utilizes rear oil cooled, multiple disc brakes)
 - Brake release motor (towing)
- Transmission
 - Seven speed automatic power shift with ICM control
 - Auto neutral idle
 - Body up shift inhibitor
 - Controlled throttle shifting
 - Directional shift management
 - Downshift inhibitor
 - Neutral coast inhibitor
 - Neutral start switch
 - Programmable top gear/speed selection
 - Reverse neutralizer during dumping
 - Reverse shift inhibitor

SUSPENSION SYSTEMS

- Hydro pneumatic suspension at front and rear

ELECTRICAL

- Alarm, backup
- Alternator, 115 ampere
- Auxiliary jump start receptacle
- Batteries, maintenance-free, 12V (2), 190 amp-hour
- Electrical system, 24V

- Lighting system
 - Backup light (halogen)
 - Directional signals/hazard warning, (front and rear LED)
 - Headlights, (halogen) with dimmer
 - Hazardous lights (LED)
 - Stop/tail lights (LED)

OPERATOR ENVIRONMENT

- HVAC
- Ashtray and cigarette lighter
- Coat hook
- Diagnostic connection port
- Entertainment radio ready
 - Speakers, antenna, wiring harness
- Air cleaner service indicator
- Transmission oil temperature gauge
- Air system pressure gauge
- Brake oil temperature gauge
- Coolant temperature gauge
- Fuel level, gauge
- Tachometer
- Speedometer with odometer
- Hour meter
- Engine overspeed indicator
- Transmission gear indicator
- Load counter, automatic
 - Advisor display
- Hoist lever
- Horn
- Mirrors, left and right
- ROPS cab, insulated/sound suppressed
- Seat, Caterpillar comfort, full air suspension and retractable four point seat belt with shoulder harness
- Audio visual seat belt remainder
- Seat, trainer with a lap belt
- Steering wheel, padded/tilt/telescopic
- Storage compartment
- Sun visor

- Throttle lock
- Right side access door
- Left side power window
- Windshield wiper, intermittent, and washer
- Tinted, laminated glass

TECHNOLOGY PRODUCTS

- Product Link™
- Telematics
- MineStar™ Ready

GUARDS

- Engine crankcase
- Driveline, operator safety vandalism protection lock

FLUIDS

- Extended life coolant to -35° C (-30° F)

OTHER STANDARD EQUIPMENT

- Airline dryer
- Body mounting group
- Body safety pin (secures body in up position)
- Body down indicator
- CD ROM parts book
- Center mounted rims
- Ground level battery disconnect
- Ground level engine shutdown
- Ground level grease fittings
- Reservoirs
 - Transmission
 - Steering
 - Brake, converter and hoist
- Rock ejectors
- Supplemental steering, automatic
- Tie down eyes
- Tow hooks, front/tow pin, rear

Standard equipment may vary. Consult your Cat dealer for detail.

For more complete information on Cat products, dealer services, and industry solutions, visit us on the web at www.cat.com

© 2016 Caterpillar
All rights reserved

Materials and specifications are subject to change without notice. Featured machines in photos may include additional equipment. See your Cat dealer for available options.

CAT, CATERPILLAR, SAFETY.CAT.COM, their respective logos, "Caterpillar Yellow" and the "Power Edge" trade dress, as well as corporate and product identity used herein, are trademarks of Caterpillar and may not be used without permission.

AEHQ7969 (11-2016)
(AME, GN1, India, Indonesia,
Southeast Asia)

