

336D2 GC

Hydraulic Excavator



Engine

Engine Model	Cat® C9 ACERT™	
Engine Power (ISO 14396)	209 kW	281 hp
Net Power (SAE J1349/ISO 9249)	208 kW	279 hp

Weights

Operating Weight – Standard Undercarriage	33 100 kg	73,000 lb
---	-----------	-----------

336D2 GC Differentiating Features

Engine and Hydraulics

A fuel efficient Cat C9 ACERT engine that meets U.S. EPA Tier 2, EU Stage II, Japan 2001 (Tier 2) equivalent, or U.S. EPA Tier 3, EU Stage IIIA, Japan 2006 (Tier 3) equivalent emission standards and China Stage III Nonroad emission standards combined with a highly efficient hydraulic system provides reduced owning and operating costs.

Structures

Caterpillar design and manufacturing techniques assure you get outstanding durability and service life in the toughest applications.

Operator Station

The spacious cab features excellent visibility and easy-to-access switches. The monitor features a full-color graphical display that is easy to see and use. Overall, the new cab provides you with a comfortable working environment for maximum production and efficiency.

Reduced Service and Maintenance Cost

Routine service and maintenance can be completed quickly and easily to help you reduce ownership costs. Convenient access points, extended service intervals, and advanced filtration help keep downtime to a minimum.

Complete Customer Support

Your Cat dealer offers a wide range of services that can be set up under a customer support agreement when you purchase your equipment.

Total Solutions

Caterpillar and its extensive dealer network offer a wide variety of solutions designed to meet the unique needs of your business.

Contents

Operator Station.....	4
Engine	6
Hydraulics	7
Structures.....	8
Front Linkage	9
Integrated Technologies.....	10
Service and Maintenance	11
Complete Customer Support.....	12
Work Tools.....	13
Specifications.....	14
Standard Equipment.....	20
Notes.....	21





The 336D2 GC is focused on life cycle value customers who work in a broad range of applications where fuel consumption and competitive performance are key attributes.

Operator Station

Ergonomically designed to keep you comfortable and productive all day long.





Cab Structure and Mounts

The cab shell is attached to the frame with viscous rubber mounts, which dampen vibrations and sound levels while enhancing your comfort. Thick steel tubing along the bottom perimeter improves the cab's resistance to fatigue and vibration.

Seat

The suspension seat provides a variety of adjustments to accommodate a wide range of operators. The seat includes a reclining back, upper and lower seat slide adjustments, and height and tilt adjustments to meet your needs for comfort and productivity.

Joystick Control and Console

Low-effort pilot-operated joystick controls are designed to match your natural wrist and arm position for maximum comfort and minimum fatigue. The right and left joystick console can be adjusted to meet your individual preferences, improving overall comfort and productivity during the course of a long work day.

Climate Control

Positive filtered ventilation with a pressurized cab is standard. Fresh air or re-circulated air can be selected with a switch on the left console.

Windows and Wipers

All glass is affixed directly to the cab to maximize visibility, eliminating window frames. The upper front windshield opens, closes, and stores on the roof above the operator with a one-touch action release system. Pillar-mounted wipers increase your viewing area and offer continuous and intermittent modes.



Monitor

The new monitor features a 40 percent larger screen with four times increased resolution display. The LCD monitor is equipped with a warning lamp and buzzer for critical engine oil pressure, coolant temperature and oil temperature. Programmable in up to 42 languages to meet today's diverse workforce, the monitor clearly displays critical information needed to operate efficiently and effectively.

Filters and fluid change intervals are available in the main menu which also projects the image from the optional rearview camera, further enhancing your job site safety and productivity.

Engine

Powerful, reliable, and fuel efficient to deliver more to your bottom line.



Emission Standards

The Cat C9 ACERT engine has been designed to meet Tier 2, Stage II, Japan 2001 (Tier 2) equivalent, or Tier 3, Stage IIIA, Japan 2006 (Tier 3) equivalent emission standards and China Stage III Nonroad emission standards. The fuel efficient engine incorporates proven robust components and precision manufacturing you can count on for reliable and efficient operation. The engine features optimized eco mode that delivers excellent performance to help reduce owning and operating costs.

Filtration System

The engine features an improved filtration system to ensure reliability even with less-than-quality fuel. Service intervals have been extended and the number of filters reduced to maximize your profit potential.

Automatic Engine Speed Control

Automatic engine speed control is activated during no-load or light-load conditions to reduce engine speed – all to help minimize fuel consumption.

Low Sound and Vibration

The Cat C9 ACERT engine is built to run quietly with limited vibration, which contributes to improving your comfort.

Hydraulics

Uncanny power and control for multiple applications.



Hydraulic System

Hydraulic system pressure from the two-pump system delivers terrific digging performance and productivity. The hydraulic system and component locations have been designed to provide a high level of system efficiency. The main pumps, control valves, and hydraulic tank are located close together to allow for shorter tubes and lines between components, reducing friction loss and pressure drops.

Pilot System

An independent pilot pump enables smooth, precise control for the front linkage, swing, and travel operations.

Hydraulic Cross-Sensing System

The hydraulic cross-sensing system utilizes each of two hydraulic pumps to 100 percent of engine power under all operating conditions. This improves productivity with faster implement speeds and quicker, stronger pivot turns.

Boom and Stick Regeneration Circuit

Boom and stick regeneration circuits save energy during boom-down and stick-in operation to increase efficiency and reduce cycle times and pressure loss for higher productivity, lower operating costs, and increased fuel efficiency.

Hydraulic Cylinder Snubbers

Snubbers are located at the rod end of the boom cylinders and both ends of the stick cylinders to cushion shocks while reducing sound levels and extending component life.

Hydraulic Activation Control Lever

With the hydraulic activation lever in the neutral position, all front linkage, swing, and travel functions are isolated.

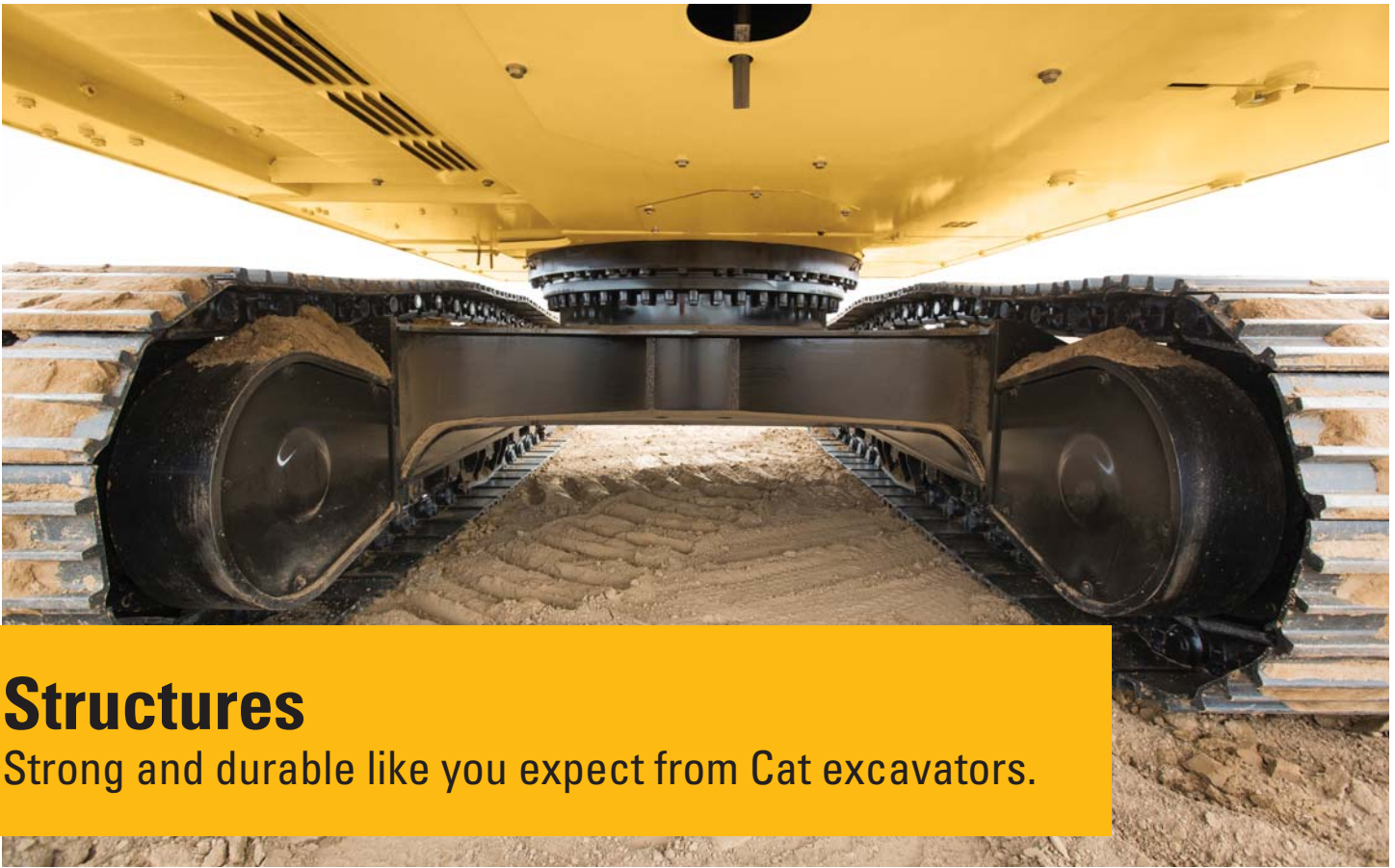

Structures

Strong and durable like you expect from Cat excavators.

Main Frame

The rugged main frame is built to perform in the toughest applications. The X-shaped, box-section carbody provides excellent resistance to torsional bending, and press-formed, robot-welded track roller frames provide exceptional strength and durability.

Rollers and Idlers

Sealed and lubricated track rollers, carrier rollers, and idlers provide excellent service life to keep your machine in the field and working longer.

Counterweight

A 5.2 mt (5.7 t) weight works well in applications that require heavy lifting. It's bolted directly to the main frame for extra rigidity.

Standard Undercarriage

An optimized standard undercarriage makes an ideal choice for life cycle value customers working across a wide range of applications.

Undercarriage

Durable Cat undercarriage absorbs stress and provides excellent stability. The 336D2 GC comes standard with grease lubricated tracks. The track links are assembled and sealed with grease to decrease internal bushing wear, reduce travel noise and extend service life lowering operating costs.

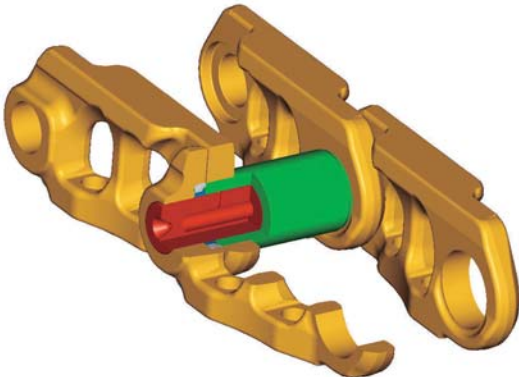



Front Linkage

Reliable, durable, and versatile to meet all your application needs.

Optimized Reach Front Linkage

The optimized reach (R) front linkage is built to work in a variety of applications. The 6.5 m (21'4") optimized reach boom is made of high-tensile-strength steel using a large box-section design with interior baffle plates and an additional bottom guard for long life and durability. The optimized R6.5 m (21'4") boom and R2.8 m (9'2") stick are extremely durable and meet all of your application needs.

Integrated Technologies

Monitor, manage, and enhance job site operations



Cat Connect makes smart use of technology and services to improve your job site efficiency. Using the data from technology-equipped machines, you'll get more information and insight into your equipment and operations than ever before.

Cat Connect technologies offers improvements in these key areas:



EQUIPMENT
MANAGEMENT

Equipment Management – increase uptime and reduce operating costs.



PRODUCTIVITY

Productivity – monitor production and manage job site efficiency.



LINK Technologies

LINK technologies like Product Link™ wirelessly connect you to your equipment, giving you valuable insight into how your machine or fleet is performing. Track location, hours, fuel usage, idle time, and event codes through the online VisionLink® interface so you can make timely, fact-based decisions that can boost job site efficiency and productivity, and lower operating costs.

Service and Maintenance

Simplified design to save you time and money.



Ground-Level Service

The design and layout of the 336D2 GC was made with the service technician in mind. Most service locations are easily accessible at ground level to allow service and maintenance to get completed quickly and efficiently.

Air Filter Compartment

The air filter features a double-element construction for superior cleaning efficiency. When the air filter plugs, a warning is displayed on the cab monitor. Maintenance-free batteries are standard along with a battery disconnect switch.

Greasing Points

A concentrated remote greasing block on the boom allows greasing of hard-to-reach locations on the boom and stick.

Fan Guard

The engine radiator fan is enclosed by a steel guard that provides maximum protection when carrying out routine service and maintenance.

Anti-Skid Plating

Anti-skid plating covers the entire upper structure and storage box to prevent slipping during maintenance. Safety is further enhanced with the addition of countersunk bolts to reduce trip hazards.

Diagnostics and Monitoring

Standard hydraulic test ports enable a service technician to evaluate the hydraulic system, engine oil, and coolant quickly and easily for more efficient maintenance.



Pump Compartment

A service door on the right side of the upper structure allows ground-level access to the hydraulic pumps, hydraulic filters, engine oil filter, and fuel filters.

Radiator Compartment

The left rear service door allows easy access to the engine radiator, hydraulic oil cooler, air-to-air aftercooler, and AC condenser. A reserve tank and drain cock are attached to the radiator for ground-level maintenance.

Complete Customer Support

A wide range of personalized solutions from your local Cat dealer.



Product Support

Cat dealers utilize a worldwide computer network to find in-stock parts to minimize machine downtime. You can also save money with our line of remanufactured components.

Machine Selection

Your Cat dealers can provide specific recommendations with detailed comparisons of the Cat machines you are considering before you buy. This ensures you get the right size machine and appropriate work tools to meet all of your application needs.

Maintenance Services

Repair option programs guarantee the cost of repairs up front. Condition monitoring services and diagnostic programs such as scheduled oil sampling, coolant sampling, and technical analysis help you avoid unscheduled repairs.

Customer Support Agreements

Cat dealers offer a variety of product support agreements that can be tailored to meet your specific needs. These plans can cover the entire machine – including attachments – to help protect your investment.

Replacement

Repair, rebuild, or replace? Your Cat dealers can help you evaluate the costs involved so you can make the right choice.

Work Tools

Dig, hammer, rip, and cut with confidence.

Versatility and Performance

Each Cat work tool is designed to optimize the versatility and performance of your machine. An extensive range of buckets, compactors, grapples, multi-processors, rippers, crushers, pulverizers, hammers, and shears is available for your 336D2 GC.

Buckets and GET

Cat buckets and Cat Ground Engaging Tools (GET) are designed and matched to the machine to ensure optimal performance and fuel efficiency.

General Duty Buckets (GD)

GD buckets are for digging in low impact, lower abrasion materials such as dirt, loam, and mixed compositions of dirt and fine gravel.

Heavy-Duty Buckets (HD)

HD buckets are a good starting point when application conditions vary – especially when conditions include mixed dirt, clay, sand, and gravel.

Severe-Duty Buckets (SD)

SD buckets are best suited to highly abrasive materials like shot rock, sand stone, and granite.

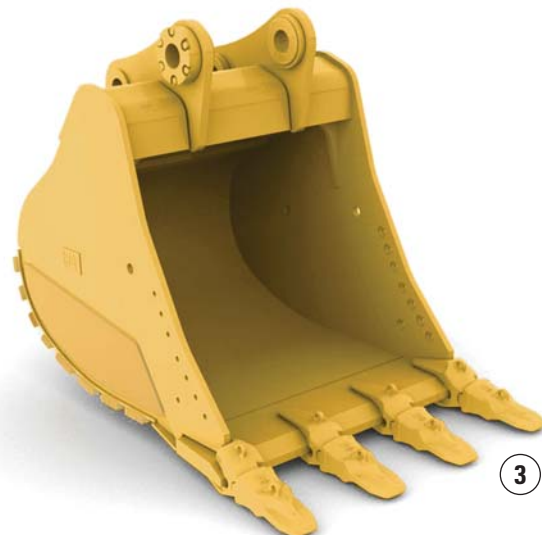

- 1) General Duty Buckets (GD)
- 2) Heavy-Duty Buckets (HD)
- 3) Severe-Duty Buckets (SD)

336D2 GC Hydraulic Excavator Specifications

Engine

Engine Model	Cat C9 ACERT	
Engine Power (ISO 14396)	209 kW	281 hp
Net Power (SAE J1349/ISO 9249)	208 kW	279 hp
Bore	112 mm	4.41 in
Stroke	149 mm	5.87 in
Displacement	8.8 L	2.3 gal

- The Cat C9 ACERT meets exhaust emissions equivalent to Tier 2, Stage II, Japan 2001 (Tier 2), or Tier 3, Stage IIIA, Japan 2006 (Tier 3) and China Stage III Nonroad emission standards.
- Net power advertised is the power available at the flywheel when the engine is equipped with fan, air cleaner, muffler, and alternator.
- The field-proven C9 ACERT engine can work efficiently at altitudes up to 2300 m (7,546 ft).

Weights

Operating Weight		
Standard Undercarriage*	33 100 kg	73,000 lb

*Standard undercarriage, 6.5 m (21'4") reach boom, 2.8 m (9'2") reach stick, 600 mm (24 in) shoes, 5.2 mt (5.7 t) counterweight.

Swing Mechanism

Swing Speed	7.9 rpm	
Swing Torque	109 kN·m	80,144 lbf·ft

Drive

Maximum Travel Speed	4.6 km/h	2.9 mph
Maximum Drawbar Pull	302 kN	67,780 lbf

Hydraulic System

Main System – Maximum Flow (each)	281 L/min	74 gal/min
Swing System – Maximum Flow	250 L/min	66 gal/min
Maximum Pressure – Equipment	35 000 kPa	5,076 psi
Maximum Pressure – Travel	35 000 kPa	5,076 psi
Maximum Pressure – Swing	28 000 kPa	4,061 psi
Pilot System – Maximum Flow	40 L/min	11 gal/min
Pilot System – Maximum Pressure	4000 kPa	580 psi
Boom Cylinder – Bore	150 mm	5.9 in
Boom Cylinder – Stroke	1440 mm	56.7 in
Stick Cylinder – Bore	170 mm	6.7 in
Stick Cylinder – Stroke	1738 mm	68.4 in
Bucket Cylinder – Bore	150 mm	5.9 in
Bucket Cylinder – Stroke	1151 mm	45.3 in

Service Refill Capacities

Fuel Tank Capacity	620 L	164 gal
Cooling System	40 L	11 gal
Engine Oil	41 L	11 gal
Swing Drive	19 L	5 gal
Final Drive (each)	8 L	2 gal
Hydraulic System Oil Capacity (including tank)	410 L	108 gal
Hydraulic Tank Oil	175 L	46 gal

336D2 GC Hydraulic Excavator Specifications

Dimensions

All dimensions are approximate.

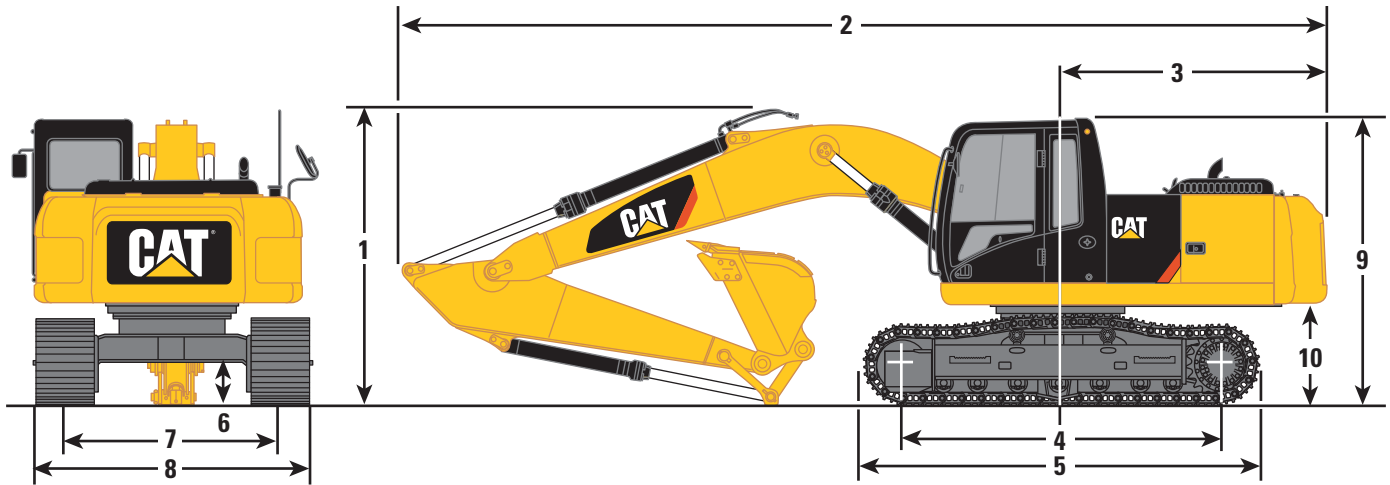

Boom Options

Reach Boom
6.5 m (21'4")

Stick Options

R2.8DB (9'2")

1 Shipping Height*	3620 mm	11'11"
2 Shipping Length	11 150 mm	36'7"
3 Tail Swing Radius	3490 mm	11'5"
4 Length to Center of Rollers – Standard Undercarriage	3610 mm	11'10"
5 Track Length – Standard Undercarriage	4590 mm	15'1"
6 Ground Clearance*	510 mm	1'8"
Ground Clearance**	480 mm	1'7"
7 Track Gauge – Standard Undercarriage	2590 mm	8'6"
8 Transport Width – Standard Undercarriage		
600 mm (24") Shoes	3190 mm	10'6"
9 Cab Height	3140 mm	10'4"
10 Counterweight Clearance**	1220 mm	4'0"
Bucket Type	DB1400HD	
Bucket Part Number	364-9498	
Bucket Capacity (SAE)	1.64 m³	2.14 yd³
Bucket Tip Radius	1757 mm	69"

*Including shoe lug height.

**Without shoe lug height.

336D2 GC Hydraulic Excavator Specifications

Working Ranges

All dimensions are approximate.

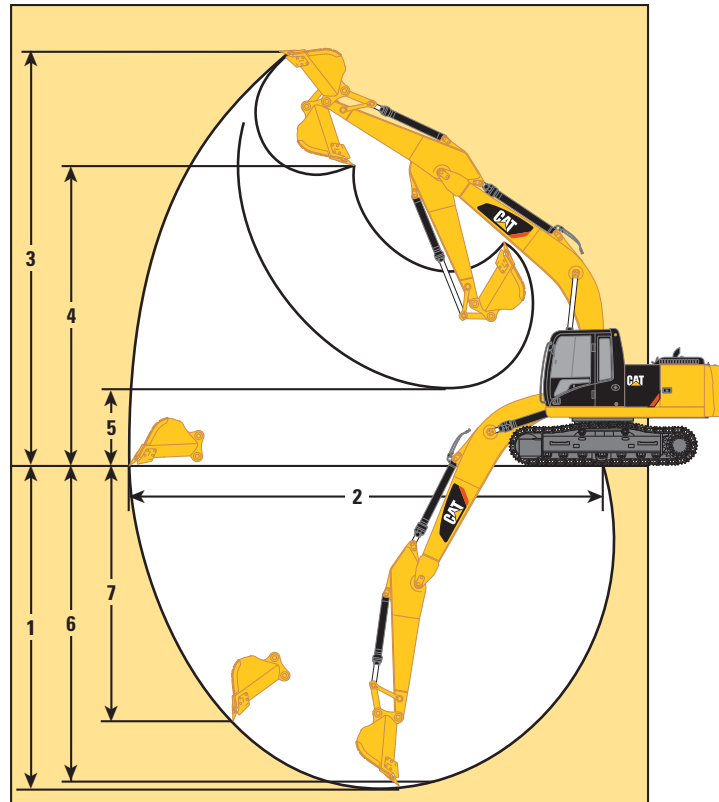

Boom Options

**Reach Boom
6.5 m (21'4")**

Stick Options

R2.8DB (9'2")

1 Maximum Digging Depth	7110 mm	23'4"
2 Maximum Reach at Ground Level	10 750 mm	35'3"
3 Maximum Cutting Height	10 320 mm	33'10"
4 Maximum Loading Height	7080 mm	23'3"
5 Minimum Loading Height	2980 mm	9'9"
6 Maximum Depth Cut for 2440 mm (8'0") Level Bottom	6950 mm	22'10"
7 Maximum Vertical Wall Digging Depth	5400 mm	17'9"
Bucket Capacity (SAE)	1.64 m³	2.14 yd³
Bucket Tip Radius	1757 mm	69"

336D2 GC Hydraulic Excavator Specifications

Major Component Weights*

Lower Structure (without counterweight and track)		
Standard Undercarriage	8000 kg	17,600 lb
Upper Structure (without front linkage)		
For 5.2 mt (5.7 t) Counterweight	8900 kg	19,600 lb
Counterweight		
5.2 mt (5.7 t)	5200 kg	11,500 lb
Boom (includes lines, pins and stick cylinder)		
Reach Boom – 6.5 m (21'4")	3900 kg	8,600 lb
Stick (includes lines, pins and bucket cylinder)		
R2.8DB (9'2")	1700 kg	3,700 lb
Track Shoe – Standard Undercarriage		
600 mm (24 in) Triple Grouser	3700 kg	8,200 lb
Buckets		
DB1400HD 364-9498 SAE 1.64 m ³ (2.14 yd ³)	1500 kg	3,300 lb
DB1400SD 356-4399 SAE 1.64 m ³ (2.14 yd ³)	1800 kg	4,000 lb
DB1500HD 456-1398 SAE 1.88 m ³ (2.44 yd ³)	1400 kg	3,100 lb

*Base machine includes 75 kg (165 lb) operator weight, 90% fuel weight, and undercarriage with center guard.

Operating Weights and Ground Pressures

	600 mm (24 in) Triple Grouser Shoes			
	Operating Weight		Ground Pressure	
Standard Undercarriage – Reach Boom 6.5 m (21'4")				
R2.8DB (9'2")	33 100 kg	73,000 lb	68.4 kPa	9.9 psi

The weight of the configuration includes 5.2 mt (5.7 t) counterweight.

Bucket and Stick Digging Forces

Boom Options	Reach Boom 6.5 m (21'4")	
Stick Options	R2.8DB (9'2")	
Heavy-Duty		
Bucket Digging Force (ISO)	211.1 kN	47,460 lbf
Stick Digging Force (ISO)	185.8 kN	41,760 lbf
Bucket Digging Force (SAE)	184.3 kN	41,440 lbf
Stick Digging Force (SAE)	179.3 kN	40,320 lbf

336D2 GC Hydraulic Excavator Specifications

Bucket Specifications and Compatibility – AME, CIS

	Linkage	Width		Capacity		Weight		Fill	Reach Boom 6.5 m (21'4")	
		mm	in	m ³	yd ³	kg	lb		%	Stick 2.8 m (9'2")
										Triple Grouser Shoes 600 mm (24")
DB Linkage without Quick Coupler										
General Duty (GD)	DB	1500	60	1.88	2.46	1280	2,822	100	⊖	
Heavy Duty (HD)	DB	1350	54	1.64	2.14	1465	3,230	100	⊕	
Maximum load pin on (payload + bucket)								kg	4415	
								lb	9,733	

Capacity based on ISO 7451.

Bucket weight with Long tips.

Maximum Material Density:

⊕ 1800 kg/m³ (3,000 lb/yd³)

⊖ 1500 kg/m³ (2,500 lb/yd³)

Caterpillar recommends using appropriate work tools to maximize the value customers receive from our products. Use of work tools, including buckets, which are outside of Caterpillar's recommendations or specifications for weight, dimensions, flows, pressures, etc. may result in less-than-optimal performance, including but not limited to reductions in production, stability, reliability, and component durability. Improper use of a work tool resulting in sweeping, prying, twisting and/or catching of heavy loads will reduce the life of the boom and stick.

Bucket Specifications and Compatibility – APD

	Linkage	Width		Capacity		Weight		Fill	Reach Boom 6.5 m (21'4")	
		mm	in	m ³	yd ³	kg	lb		%	Stick 2.8 m (9'2")
										Triple Grouser Shoes 600 mm (24")
DB Linkage without Quick Coupler										
General Duty (GD)	DB	1500	60	1.87	2.44	1311	2,890	100	⊖	
Heavy Duty (HD)	DB	1350	54	1.64	2.14	1481	3,265	100	⊕	
Severe Duty (SD)	DB	1400	55	1.64	2.14	1691	3,729	90	⊕	
Maximum load pin on (payload + bucket)								kg	4415	
								lb	9,733	

Capacity based on ISO 7451.

Bucket weight with Long tips.

Maximum Material Density:

⊕ 1800 kg/m³ (3,000 lb/yd³)

⊖ 1500 kg/m³ (2,500 lb/yd³)

Caterpillar recommends using appropriate work tools to maximize the value customers receive from our products. Use of work tools, including buckets, which are outside of Caterpillar's recommendations or specifications for weight, dimensions, flows, pressures, etc. may result in less-than-optimal performance, including but not limited to reductions in production, stability, reliability, and component durability. Improper use of a work tool resulting in sweeping, prying, twisting and/or catching of heavy loads will reduce the life of the boom and stick.

336D2 GC Hydraulic Excavator Specifications

Reach Boom Lift Capacities – Counterweight: 5.2 mt (5.7 t)

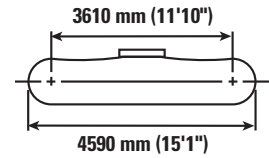
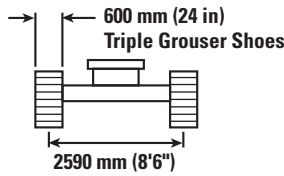
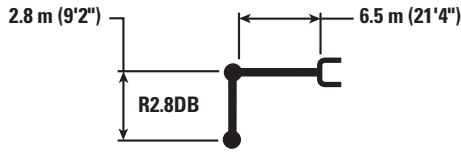

		3000 mm/120 in		4500 mm/180 in		6000 mm/240 in		7500 mm/300 in		9000 mm/360 in		mm in		
7500 mm 300 in	kg lb											*8550 *18,900	6550 14,800	7340 290
6000 mm 240 in	kg lb					*9150 *19,850	9050 19,500	*8500 18,400	6300 13,500			7250 16,150	5300 11,800	8250 330
4500 mm 180 in	kg lb			*13 200 *28,300	*13 200 *28,300	*10 400 *22,450	8600 18,500	8350 17,950	6100 13,100			6400 14,150	4650 10,250	8820 350
3000 mm 120 in	kg lb			*16 400 *35,200	12 050 26,050	11 300 24,350	8050 17,350	8050 17,350	5800 12,500	6100 4400		6000 13,150	4300 9,450	9110 360
1500 mm 60 in	kg lb			*15 950 36,250	11 300 24,300	10 800 23,300	7600 16,350	7800 16,800	5550 12,000	5950 4300		5850 12,850	4200 9,200	9140 360
0 mm 0 in	kg lb			16 550 35,550	11 000 23,700	10 500 22,650	7300 15,750	7600 16,400	5400 11,600			6000 13,150	4250 9,350	8920 350
-1500 mm -60 in	kg lb	*12 400 *28,250	*12 400 *28,250	16 550 35,500	11 000 23,700	10 450 22,400	7250 15,550	7550 16,250	5350 11,500			6450 14,250	4600 10,150	8420 340
-3000 mm -120 in	kg lb	*21 500 *46,700	*21 500 *46,700	*16 350 *35,400	11 200 24,050	10 500 22,600	7300 15,750	7650 15,750	5450			7550 16,700	5350 11,850	7600 300
-4500 mm -180 in	kg lb	*17 150 *36,800	*17 150 *36,800	*13 300 *28,500	11 550 24,900	*9900 *20,800	7600 16,450					*9050 *19,850	7100 16,000	6330 250



ISO 10567



*Indicates that the load is limited by hydraulic lifting capacity rather than tipping load. The above loads are in compliance with hydraulic excavator lift capacity standard ISO 10567:2007. They do not exceed 87% of hydraulic lifting capacity or 75% of tipping load. Weight of all lifting accessories must be deducted from the above lifting capacities. Lifting capacities are based on the machine standing on a firm, uniform supporting surface. The use of a work tool attachment point to handle/lift objects, could affect the machine lift performance.

Lift capacity stays with ±5% for all available track shoes.

Always refer to the appropriate Operation and Maintenance Manual for specific product information.

336D2 GC Standard Equipment

Standard Equipment

Standard equipment may vary. Consult your Cat dealer for details.

ENGINE

- Diesel C9 ACERT engine
- 2300 m (7,546 ft) altitude capability
- 65 amp alternator
- Air intake heater
- Radial seal air filters (primary and secondary filter)
- Automatic engine speed control
- Water separator with water level indicator sensor
- Waved fin radiator with space for cleaning
- Two-speed travel
- Two (2) micron fuel filters
- Electric priming pump

HYDRAULIC SYSTEM

- Capability of installing additional valves and circuits
- Regeneration circuits for boom and stick
- Reverse swing damping valve
- Automatic swing parking brake

CAB

- Retractable seat belt – 51 mm (2 in)
- 70/30 split front windshield
- Laminated upper front windshield and tempered other windows
- Sliding upper door window
- Bi-level air conditioner (automatic) with defroster (pressurized cab)
- Color LCD display with warning, filter/fluid change, and working hour information
- Neutral lever (lock out) for all controls
- Travel control pedals with removable hand levers
- Radio mounting (DIN size)
- Two stereo speakers
- Beverage holder
- Coat hook, ashtray, literature holder
- Openable roof hatch
- Washable floor mat

FRONT PARTS

- 6.5 m (21'4") optimized Reach boom
 - Optimized R2.8DB stick
- Bucket linkage
 - DB Bucket linkage (without lifting eye)

UNDERCARRIAGE

- Idler and center section track guiding guards
- Towing eye on base frame
- Grease lubricated track GLT2, resin seal
- 600 mm (24 in) Triple Grouser tracks

ELECTRICAL

- Circuit breaker
- Light, boom mounted, left and right
- Light, storage box mounted

SAFETY AND SECURITY

- Cat one key security system
- Door and compartment locks
- Signaling/warning horn
- Rearview mirrors
- Emergency engine shutoff switch
- Emergency exit rear window
- Capability to connect a beacon

COUNTERWEIGHT

- 5.2 mt (5.7 t) counterweight

INTEGRATED TECHNOLOGIES

- Cat Product Link

For more complete information on Cat products, dealer services, and industry solutions, visit us on the web at www.cat.com

AEHQ7630 (08-2015)

© 2015 Caterpillar
All rights reserved

Materials and specifications are subject to change without notice. Featured machines in photos may include additional equipment. See your Cat dealer for available options.

CAT, CATERPILLAR, SAFETY.CAT.COM, their respective logos, "Caterpillar Yellow" and the "Power Edge" trade dress, as well as corporate and product identity used herein, are trademarks of Caterpillar and may not be used without permission.

VisionLink is a trademark of Trimble Navigation Limited, registered in the United States and in other countries.

