

Performance
DURABILITY ◀
Reliability

Compact + ◀

Shuttle Transmission

SPECIFICATIONS

FEATURES

- Industry leading durability and reliability
- Refined and matured design
- Precision helical gearing for greater noise reduction
- Smooth and easy shifting reducing operator fatigue
- Compact layout for ease of installation
- Extensive option list to suit specific applications (see back for details)
- 120 Horse Power 90 kilo Watts
- 2wd and 4wd options

DESIGN BENEFITS

- All gear changes fully synchronised
- Directional changes without braking for decreased cycle times
- 'Engage on the move' AWD for convenience and improved braking
- Co-axial pump allows easy auxiliary pump installation
- Wide range of flexible gear ratios to optimised performance
- Optional integrated hydraulic supply allows for control of machine systems

Compact + Specifications

RATINGS

Ratings Input Power 120hp / 90kW
 Rating Input Torque 600 lb.ft / 800Nm
 Rated Input Speed 2,400 rpm
 Maximum Input Speed 2,600 rpm
 Minimum Input Speed 600 rpm
 All Ratings Subject to Duty Cycle and Application Approval.

POWER TAKE OFF (PUMP AUXILIARY DRIVE)

Mounting SAE "C" 2 Bolt
 Drive on Rear of
 Transmission
 Rated Power 80 hp / 60 kW

CLUTCHES

Clutches Electro-Hydraulic,
 Oil-Cooled,
 Multidisc
 Clutch Modulation Control Hydromechanical
 Modulation Valve

GEARS

Gearing Type Helical
 Standard Gear Ratios
 1F/R 4.824 6.119
 2F/R 2.998 3.238
 3F/R 1.408 1.665
 4F/R 0.652 0.950
 4 Wheel Drive Ratio 0.973 1.000
 (Rotation Opposite to Engine)

OPTIONAL FEATURES

- Torque converter to match co-axial pump drive machine application
- Various ratios available to match the application
- Ability to lock out 4th gear for 20 kp/h TUV regulations
- 2WD and 4WD versions available
- Temperature and speed sensors available
- Integrated hydraulic supply for machine systems
- Fully modulated control valves for directional changes
- Available with or without pump drive
- SAE "C" 2 or 4 bolt pump drive mount available
- Caliper park brake available
- Optional electrical connectors Deutsch, AMP or DIN
- 4 wheel drive options:
 - Full multi-plate clutch pack 'engage on the move'
 - 'Sprung on' electro-hydraulic disconnect
 - Permanent 4 wheel drive
- Remote mount transmission option available

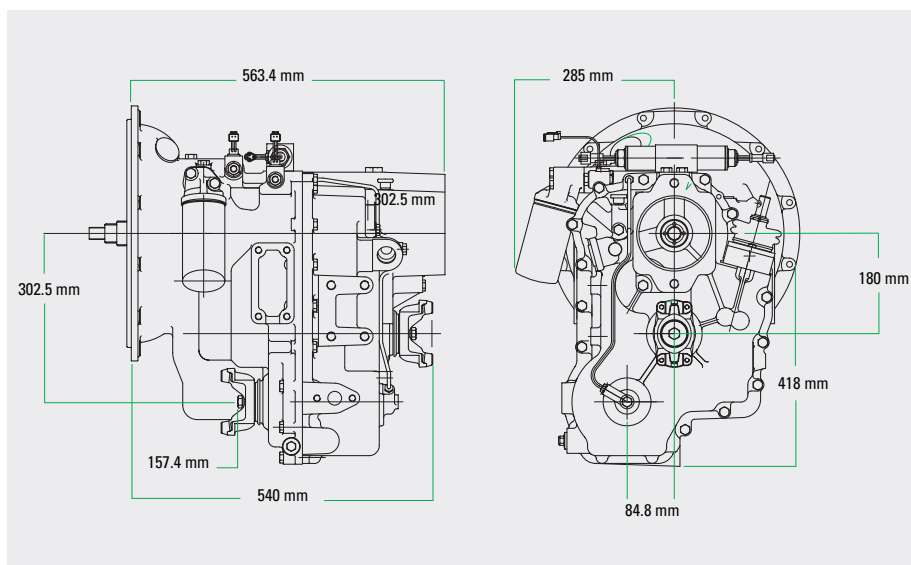

Caterpillar

1st Floor Hexagon House
 No.3 Trinity Court
 Wolverhampton Business Park
 Wolverhampton
 United Kingdom
 WV10 6UH

Sales Enquiries Telephone
 +44 (0) 1455 825022

General Enquiries Telephone
 +44 (0) 1902 625627