



**Prime 275kVA (220kW)
50/60 Hz Switchable
EU Stage IIIA**

Image shown may not reflect actual configuration

Specifications

Frequency (Hz)	Speed (rpm)	Voltage	Prime		Output Amps (A)	Breaker Rating (A)
			kVA	kW		
50	1500	415 / 240 V	275	220	383	630
		400 / 230 V	275	220	397	
		380 / 220 V	275	220	418	
60	1800	480 / 277 V	344	275	413	630
		440 / 254 V	344	275	451	
		380 / 220 V	300	240	456	
		240 / 139 V	344	275	827	1000
		220 / 127 V	344	275	902	

Cat® C9 ACERT™ Diesel Engine	Metric	Imperial (English)
Configuration	Inline 6-cylinder, 4-Stroke-Cycle, Water Cooled, Diesel	
Bore	112 mm	4.4 in
Stroke	149 mm	5.9 in
Displacement	8.8 L	537 in ³
Aspiration	Turbocharged-Aftercooled (TA)	
Compression Ratio	16.1:1	
Engine rpm	1500-1800	
Aftercooler Type	ATAAC	
Turbocharger	Single	
Fuel System	Direct Injection, MEUI™	
Governor Type	Electronic ECM controlled (A4:E2)	
Fuel	See Fuel Specification Table	

Benefits & Features

Rental-ready Features

- Dual wall fuel tank
- Forklift pockets
- Integrated heavy duty drag bar with robust skid plate base
- Externally certified single point lift
- Coolant and oil drains piped to baseframe
- Externally certified spark arrest silencer
- 50/60Hz frequency switch via terminal link
- EMC certified
- Robust busbar connection for lugged cable connection
- Sound isolated rear mounted control panel
- AC protected by limit switch on distribution door

Fuel/Emissions Strategy

- EU Stage IIIA

Single-source Supplier

- Factory designed and fully prototype tested with torsional vibration analysis available
- ISO 9001:2000 compliant facility

Cat C9 ACERT™ Diesel Engine

- Four-stroke diesel engine combines consistent performance and excellent fuel economy with minimum weight
- Electronic ECM control

Cat EMCP 4.2B Control Panel

- Fully featured power metering, protective relaying, engine/generator control and monitoring
- Simple, user-friendly interface and navigation
- Single point interface for voltage and frequency adjustment

Optional Control Panels

- Cat EMCP 4.4, DEIF® AGC-4 and ComAp® IntelliGen NT
- Synchronising capabilities
- Motorised breaker
- Ethernet remote monitoring
- Large screen interface

Available Options

- CE socket box with integrated MCB & RCBO protection
- Synchronising control panel and motorised breaker
- 220-240V 3-phase 60Hz configuration available with appropriately sized breaker and power cables
- Anti condensation heater 230V AC
- Coolant heater 230V AC
- 24V battery charger
- Permanent Magnet Generator (PMG)
- Earth leakage detection
- Lube oil sump pump

Cat LC5100 Generator

- Designed to match performance and output characteristics of Cat diesel engines
- Coastal insulation protection
- Self (Shunt) excitation

Integrated Voltage Regulator (IVR)

- Three-phase sensing
- Adjustable Volts-per-Hertz regulation
- Provides precise control, excellent block loading, and constant voltage in the normal operating range

Enclosure

- Galvanized sheet steel construction
- Two coat polyester powder-coated finish
- 5 access doors for improved service access
- Secure design with safety glass control panel viewing window and padlockable or keylock access doors
- Fuel fill, battery and controls accessible only through lockable access doors

Environmental Considerations

- Dual wall base tank with 110% spill containment
- Bund Level alarm
- Low noise enclosure
- Inboard mounted 3-way valve for external fuel connection

Cat Connect

- Fleet management and asset tracking*

*Subject to local certifications

Standard Equipment

Generator

- LC5114J frame; 3-phase random wound, 12 lead, self excited, 2/3 pitch
- Coastal insulation protection (CIP)

Cat C9 ACERT™ Diesel Engine

- Turbocharged, air-to-air aftercooler
- Electronic ECM control

Air Filter

- Air cleaner, cyclonic/paper with dust cup and service indicator

Cooling System

- Variable speed fan
- Package mounted radiator with vertical air discharge
- High ambient performance
- Fully guarded pusher fan
- Low coolant level shutdown
- Coolant piped to base via radiator-mounted ball valve
- 50% glycol mix with corrosion inhibitor

Charging System

- Charging alternator; 24V, heavy duty with integral regulator and belt guards

Starting System

- Single 24V electric starting motor
- 2x12V 950CCA maintenance-free battery with padlockable single-pole isolator switch

Fuel System

- Dual wall fuel tank
- Internal fuel fill
- Engine mounted primary and secondary fuel filter
 - Primary filter (10 micron) with integral water separator (330ml capacity)
 - Secondary filter (4 micron)
- Manual push button priming pump
- Auxiliary connections for remote supply with 3-way valve
- 3-way valve internally mounted within banded area
- Mechanical fuel gauge
- Electronic fuel gauge with panel display, low fuel level warning and shutdown

Control Panel

- EMCP 4.2B set mounted digital controller
- 50/60Hz frequency switch (via terminal link)
- IVR with EM10 excitation module
- Panel & enclosure mounted emergency stop

Distribution System

- Separate robust steel enclosures for control & distribution sections
- Distribution door protected with 24V DC shunt trip safety switch
- 4 pole, 630A main circuit breaker
- Two-wire remote start/stop terminals and AC aux power connection for rapid starting

Mounting System

- Heavy duty steel baseframe with integral fuel tank (dual wall)
- Provides 110% spill containment including all on-board fluids
- Forklift pockets
- Heavy duty drag bar with skid plates
- Generator set soft mounted using captive vibration mounts

Enclosure

- Sound attenuating, galvanised sheet steel enclosure with exceptional noise reduction performance
- Interior walls, ceilings and ducts insulated with precision cut noise insulating materials
- Sealed quarter-turn compression latches with key or padlock capabilities
- External side-mounted dual point lifting frame for improved hook access
- Powder coated with Cat Rental Power decals

Exhaust System

- Integrated certified spark arresting silencer with flexible connectors
- Outlet box mounted with vertical discharge

Lube Oil System

- On-engine primary and secondary oil filters, dipstick and oil filler
- Open crankcase breather with fumes disposal container and drain point
- Oil piped to edge of baseframe with internally mounted ball valve
- 500 hour oil change requirement

General

- Factory Tested
- Full manufacturer's warranty, O&M manuals

Fuel Specifications

Specification Standard	Grade Class	Fuel Description
EN 590	Grade A to F & Class 0 to 4	European automotive fuel (DERV)
ASTM D975	1-D S15	U.S. special purpose light middle distillate
		15ppm sulphur
ASTM D975	2-D S15	U.S. special purpose light middle distillate
		15ppm sulphur
JIS K2204	No. 1	Japanese automotive diesel. Different classes correspond to season and district where used
	No. 2	
	No. 3	
	Special No. 3	
BS 2869	Class A2	Fuel oil for agriculture and industrial engines (red diesel)
MIL-DTL-83133 NATO F34	JP-8	Aviation kerosene fuels - acceptable when used with appropriate lubricity additive, and must meet minimum requirements of Caterpillar Specification for Diesel Fuel. The lubricity of these fuels must not exceed wear scar diameter of 0.52mm (0.02047 in) as per ISO 12156-1
MIL-DTL-83133 NATO F35		
MIL-DTL-5624 NATO F44	JP-5	
MIL-DTL-38219 (USAF)	JP-7	
NATO XF63		
ASTM D1655	JET A	
	JET A1	
B5-B7		
B7-B20		



Technical Data

Cat Generator	
Frame size	LC5114J
Pitch	2/3
No. of poles	4
Excitation	Static regulated, brushless, self excited
Number of bearings	Single bearing, close coupled
Insulation	Class H
Temperature rise	125/40°C
Enclosure	Drip proof IP23
Overspeed capability — % of rated	25%
Voltage regulator	3-phase sensing with adjustable volts per hertz
Voltage regulation	Less than ± 0.5%
Wave form deviation	
Telephone Influence Factor (TIF)	Less than 2%
Harmonic Distortion (THD)	Less than 2%

Cat Generator Set			
	TMI Performance No. Units	Prime — 50 Hz EM1549	Prime — 60 Hz EM1551
Power Rating	kVA (kW)	275 (220)	313 (250)
Performance Specification			
Lubricating System			
Oil pan capacity	L (gal)	39 (10.3)	
Fuel System			
Fuel consumption — 100% Load	L/hr (gal/hr)	59.7 (15.8)	75.7 (20)
75% Load	L/hr (gal/hr)	48.1 (12.7)	59.9 (15.8)
50% Load	L/hr (gal/hr)	35.5 (9.4)	43.8 (11.6)
Fuel tank capacity	L (gal)	717 (189.4)	
Running time @ 75% rating	Hr	15	12
Cooling System			
Ambient capability	°C (°F)	35 (95)	35 (95)
21 (5.5)Engine & radiator coolant	L (gal)	48 (12.7)	48 (12.7)
Engine coolant capacity	L (gal)	13.9 (3.7)	13.9 (3.7)
Air Requirements			
Combustion air flow	m ³ /min (cfm)	16.0 (565)	22.2 (784)
Exhaust System			
Exhaust flow at rated — dry exhaust	m ³ /min (cfm)	43 (1515)	57 (2027)
Exhaust temperature at rated kW	°C (°F)	671 (1240)	658 (1216)
Noise Rating (with enclosure)*			
Sound Power*	dB(A)	95	97
@ 7 meters @ 75% load	dB(A)	-	-
@ 7 meters @ 100% load	dB(A)	64.4	66.2
@ 1 meter @ 75% load	dB(A)	-	-
@ 1 meter @ 100% load	dB(A)	71.7	74.9

*Guaranteed sound power as per 2000/14/EC

Technical Data (continued)

Cat Generator Set			
	TMI Performance No. Units	Prime — 50 Hz EM1549	Prime — 60 Hz EM1551
Emissions data at 100% Load			
Nox	g/hp-hr	4.66	4.03
CO	g/hp-hr	1.48	0.84
HC	g/hp-hr	0.04	0.05
PM	g/hp-hr	0.04	0.05

For full Engine & Emissions data please refer to TMI using the engine performance no.

Dimensions			
	Length mm (in)	Width mm (in)	Height mm (in)
Generator Set	4065 (160)	1400 (55)	2124 (84)

Weight	
	Weight — kg (lb)
Lube Oil & Coolant — Empty Fuel Tank	3880 (8553)
Full Fuel Tank	4518 (9960)

Sockets	15A	16A	32A	50A	63A	125A
CEE Form*	–	2x1ph+N+E	2x3ph+N+E	–	1x3ph+N+E	1x3ph+N+E

*Busbar connection is standard. Distribution sockets are optional.

Layout for General Dimensions

Dimensions in millimeters

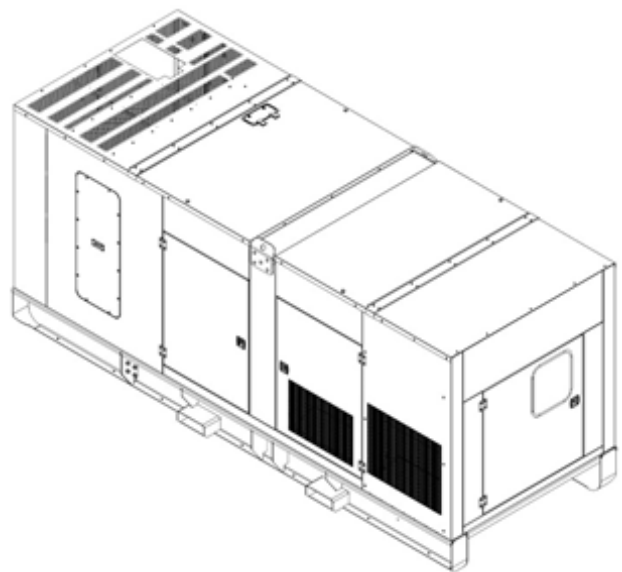
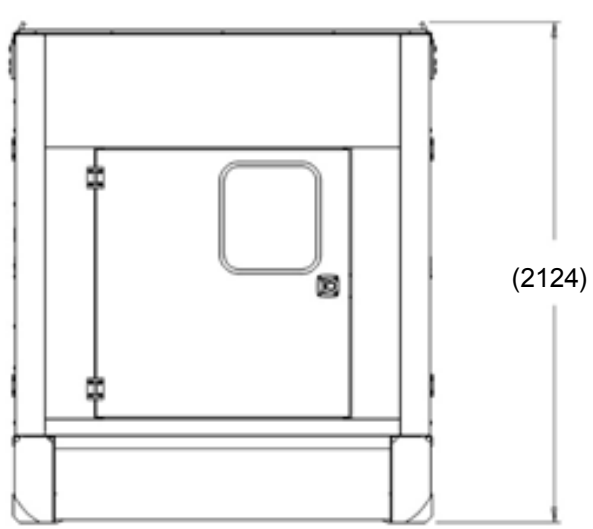
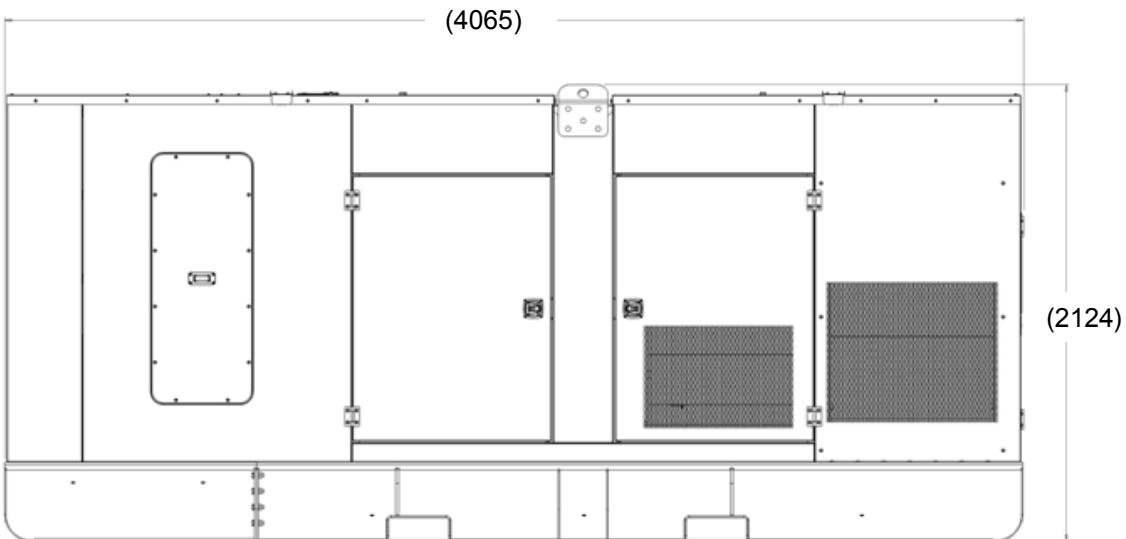
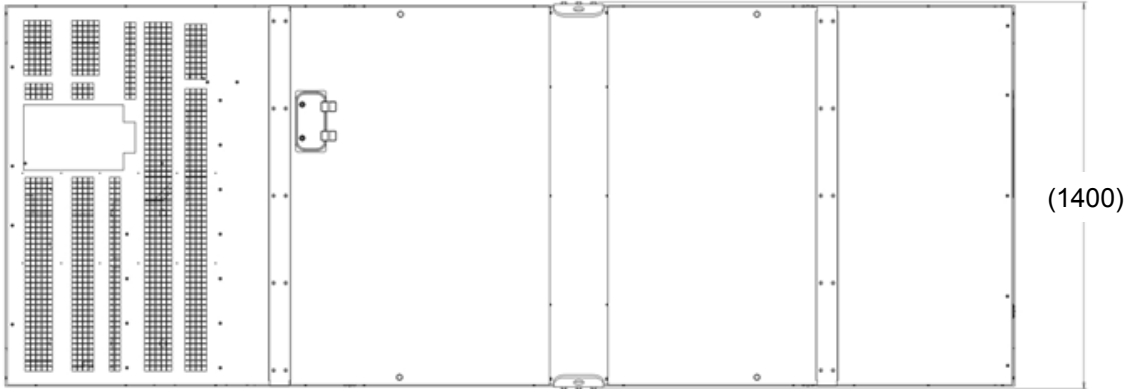

Control Panel and Power Distribution Layout

Item	Description
1	Steel enclosure with hinged, lockable door (not shown)
2	EMCP 4.2B digital genset controller
3	Emergency Stop button
4	Alarm
5	Service tool connector
6	Circuit breaker. 4-pole molded case, 630A
7	Main bus connection (bus bars with 14 mm holes)
8	Micro safety switch for bus bar door
9	Manual holder

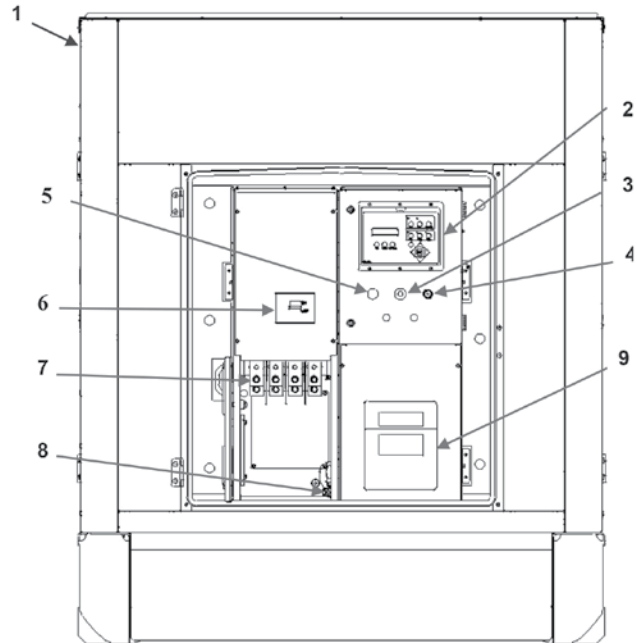

Rating Definitions and Conditions

Designed to Meet Specifications: ISO 8528, EN 12601, EN 60204-1, ISO 3046, IEC 60034.

Ratings are based on SAE J1349 standard conditions. These ratings also apply at ISO3046 standard conditions.

Prime — Output available with varying load for an unlimited time. Average power output is 70% of the prime power rating. Typical peak demand is 100% of prime rated kW with 10% overload capability for emergency use for a maximum of 1 hour in 12. Overload operation cannot exceed 25 hours per year.

Fuel rates are based on fuel oil of 35° API [16°C (60°F)] gravity having an LHV of 42 780 kJ/kg (18,390 Btu/lb) when used at 29°C (85°F) and weighing 838.9 g/liter (7.001 lbs/U.S. gal).

Additional ratings may be available for specific customer requirements, contact your Cat representative for details. For information regarding low sulfur fuel and biodiesel capability, please consult your Cat dealer.

www.Cat.com/rentalpower

©2018 Caterpillar
All rights reserved.

Materials and specifications are subject to change without notice. The International System of Units (SI) is used in this publication.

CAT, CATERPILLAR, their respective logos, "Caterpillar Yellow", ACERT, the "Power Edge" trade dress as well as corporate and product identity used herein, are trademarks of Caterpillar and may not be used without permission.